

TOPICS IN WARLPIRI GRAMMAR

by

DAVID GEORGE NASH

B.A., Australian National University  
(1973)

M.A., Australian National University  
(1975)

SUBMITTED IN PARTIAL FULFILLMENT  
OF THE REQUIREMENTS FOR THE  
DEGREE OF

DOCTOR OF PHILOSOPHY

at the

MASSACHUSETTS INSTITUTE OF TECHNOLOGY

May 1980

© Massachusetts Institute of Technology 1980

Signature of Author.....  
Department of Linguistics and Philosophy  
May 19, 1980

Certified by.....  
Kenneth L. Hale  
Thesis Supervisor

Accepted by.....  
Samuel Jay Keyser  
Chairman, Departmental Committee

HUM.  
MASSACHUSETTS INSTITUTE  
OF TECHNOLOGY

JUN 9 1980

LIBRARIES

## TOPICS IN WARLPIRI GRAMMAR

by

DAVID GEORGE NASH

Submitted to the Department of Linguistics & Philosophy  
on May 19, 1980 in partial fulfillment of the  
requirements for the Degree of Doctor of Philosophy

## ABSTRACT

This dissertation investigates aspects of the morphology, phonology, syntax and semantics of the Warlpiri (Walbiri) language of central Australia.

The Introduction surveys previous work on Warlpiri, the sources of data for this work, and brings out themes recurrent in later Chapters.

Chapter Two is a detailed presentation of Warlpiri morphology. A labelled-bracket notation encapsulates the rules of word-formation and gives the concatenative and hierarchical structure exhibited by Warlpiri words. The special properties of verbal inflexion and the Auxiliary word are examined. Compounds, the special category of Preverb, and properties of enclitics, are all incorporated into the model used for simple words.

Chapter Three uses standard distinctive features to present morpheme structure constraints of various morpheme classes, and to describe the few processes of segmental phonology. There are two vowel harmony processes which are related and explained using an autosegmental theory. Word stress is accounted for within metrical theory, using the morpheme as the domain of initial foot construction. The accounts extend to harmony and stress in compound words.

Chapter Four details the properties of nominal and verbal reduplication, and distinguishes between lexical reduplications (with compound structure) and productive verbal reduplication (which copies the initial foot). Numerous examples illustrate the various semantic effects.

Chapter Five turns to syntax. Warlpiri exhibits great freedom of word order (within finite clauses); theoretical perspectives on word order variation are surveyed. A novel approach to Warlpiri's non-configurational syntax (based on work by Hale) is presented, involving rules labelling phrasal nodes with categorial signatures based on morphological categories.

Chapter Six sketches the predictability of a predicate's case frame given the thematic roles of each argument position, within theories of "case linking" (Carter, Ostler). The account covers diathetical variants of certain verbs.

Chapter Seven gives rules of semantic interpretation by which the lexical argument structures (Chapter 6) combine with syntactic structures (Chapter 5). Minor interpretive rules dependent on word order are listed.

An Appendix lists all known Warlpiri verb roots with their case frames.

Thesis Supervisor: Kenneth Hale

Title: Professor of Linguistics

## ACKNOWLEDGEMENTS

There are many people I would like to thank for all sorts of things during my time at M.I.T. I mention only a fraction of these people here, those who particularly assisted me in the preparation of this work.

My greatest debt is to Ken Hale. His enthusiasm in sharing his penetrating insights into Warlpiri and grammar has been an inspiration. I count myself extremely fortunate that I have had the opportunity of his patient and attentive supervision over the past years.

Two other members of my thesis committee, Joan Bresnan and Paul Kiparsky, both made a number of pointed and useful comments on the draft. Their influence runs deeper than the Bibliography indicates. Morris Halle's kindness and unfailing help have benefited me considerably. It is difficult to adequately thank Mary Laughren, who bore with equanimity my continual accessing of her knowledge of Warlpiri. And other people I want to thank for discussing various topics of this work include Barry Alpher, Peter Austin, Lauri Carlson, Dick Carter, Noam Chomsky, Alec Marantz, John McCarthy, Nick Ostler, David Pesetsky, Haj Ross, Jane Simpson, and Donca Steriade.

Randy Austin's custom typing service was a boon.

My special indebtedness to Ken Japanangka and Mary Napaljarri, and the Warlpiri people who taught them the language, should be clear from the references throughout.

This work has been supported in part by National Institute for Mental Health grant MH 13390, and, in the final year, by National Science Foundation grant BNS-7913950.

## TABLE OF CONTENTS

Abstract	2
Acknowledgments	3
Chapter 1: Introduction	8
1.1 Previous work, and the data used	8
1.2 Notation	10
1.3 Overview	11
Chapter 2: Morphology and Word-formation	13
2.1 Parts of speech	13
2.2 Structure of the lexicon	18
2.3 Suffixes	22
2.3.1 N formatives	22
2.3.1.1 N from N	22
2.3.1.2 N from Infinitives	25
2.3.1.3 Unproductive N formatives	25
2.3.1.4 N from Verbs	29
2.3.2 Case formatives	30
2.3.3 Complementiser formatives	31
2.3.3.1 [+C] Complementisers	32
2.3.3.2 [-C] Complementisers	32
2.3.4 Argument formatives	33
2.3.5 Summary	36
2.4 Compounding	37
2.4.1 Productive patterns	37
2.4.2 Non-productive patterns	39
2.5 Verbal inflexions	40
2.6 Preverbs	42
2.6.1 N, CASE as Preverbs	42
2.6.2 INF as Preverb	44
2.6.3 Verb roots as Preverbs	46
2.6.4 "Pure" Preverbs	47
2.6.4.1 Productive Preverbs	47
2.6.4.2 Non-productive Preverbs	49
2.6.5 Permutation of Preverb and Verb	51

2.7 Enclitics	55
2.7.1 The Auxiliary word	58
2.7.2 Directionals	62
Chapter 3: Phonology	65
3.1 Distinctive features	65
3.2 Morpheme structure conditions	67
3.3 Cluster simplifications and the syllable	78
3.4 Vowel assimilations	80
3.5 Vowel harmony	84
3.5.1 Autosegmental account of vowel harmony	88
3.5.2 Alternative "symmetrical" account	96
3.5.3 The domain of harmony	98
3.6 Stress	99
3.6.1 Basic stress patterns	99
3.6.2 Metrical theory	102
3.6.3 Rules building metrical structure	103
3.6.3.1 Foot placement	103
3.6.3.2 Word level metrical structure	107
3.6.4 Examples	108
3.6.4.1 Compound level stress	110
3.6.4.2 Stress on Verbs	112
3.6.5 Remaining problems	115
Chapter 4: Reduplication	117
4.1 Lexical Nominal reduplication	118
4.1.1 Semantics of Nominal reduplication	121
4.1.2 Near reduplications	124
4.1.3 Morpheme structure conditions	128
4.2 Regular [+N] reduplication	130
4.3 Stress on nominal reduplications	134
4.4 Regular Verbal reduplication	136
4.4.1 Properties peculiar to V reduplication	141
4.4.2 Semantics of Verbal reduplication	145
Chapter 5: Syntax	
5.1 Word order	148
5.1.1 Freedom of word order	150

5.1.2 Hybrid languages and typological variation	151
5.1.3 Warlpiri as a "scrambling" language	157
5.2 Model of the grammar	162
5.3 Categorical signatures	165
5.4 "Labelling" Rules	168
5.4.1 Labelling of complex nominals	169
5.4.1.1 Number	174
5.4.1.2 Double case marking	175
5.4.1.3 Co-ordination	176
5.4.2 Complex complements	178
5.4.2.1 Infinitive complements	178
5.4.2.2 Nominal complements	180
5.4.3 Sentences	181
5.5 Unlabelled nodes	183
5.6 Auxiliary placement	185
5.6.1 Modal Particles	186
Chapter 6: The Linking of Case	188
6.1 Regular linking	192
6.1.1 Doubly-classified verb roots	195
6.1.2 Cognate object constructions	196
6.1.3 The ERG-DAT construction	197
6.1.4 Dative adjunct Preverbs	200
6.2 Other linkings	201
6.2.1 Special linkings	201
6.2.2 Linkings to semantic cases	203
6.2.3 Other diatheses	204
6.3 Linking in Nominal predicates	205
6.3.1 Predicational elaboration of N	206
6.3.2 Nominals with complements	207
Chapter 7: Semantic Interpretation	
7.1 Introduction	211
7.2 Merger	212
7.3 Construal	216
7.3.1 Construal of pronominal clitics	217
7.3.2 Control and Obviation	221

7.3.3 Predicational Adjunction	225
7.4 Tense and Aspect	229
7.5 Evaluation	230
7.6 Order-dependent processes	232
7.6.1 Infinitival complements	233
7.6.1.1 Obviative complement subject	233
7.6.1.2 Infinitive complement object	234
7.6.2 Interrogative words	235
7.6.3 Scopal phenomena	237
7.7 Relative clauses	240
Appendix: Warlpiri Verb roots	242
Bibliography	
Part I: Works chiefly concerned with Warlpiri	247
Part II: Other works	249
Biographical note	255

This work investigates a number of topics in the grammar of the Warlpiri (previously spelled Walbiri, and in other ways) language. This language is spoken by a growing population, upwards of 2,500 people, at a number of centres in the central western area of the Northern Territory of Australia. It ranks these days among the most populous of the Australian languages, and has no chance of joining the hundreds of other related languages of the continent that have succumbed after a century or two of European occupation.

Warlpiri belongs to the Pama-Nyungan group of the Australian language family. Blake, 1977, and Dixon (ed.), 1976, assemble much material on Australian languages, and many references to other works. Published grammars of other Pama-Nyungan languages include Dixon, 1972, 1977, Donaldson, 1980, and a number of others not in the Bibliography. For languages quite similar to Warlpiri, see Hansen & Hansen, 1978 and Hudson, 1978. Warlmanpa (Nash, 1979b) seems to be the language most closely related to Warlpiri.

The Warlpiri are also the subject of a detailed ethnography -- Meggett, 1962; and of two detailed sign-language studies -- Kendon, 1978, (and work in progress), and a dictionary (in press) by Cheryl Wright.

### 1.1 PREVIOUS WORK, AND THE DATA USED

One of the occupational hazards of linguistic work with a language with only a brief literary and philological tradition is the paucity of sources of written data available to non-specialist researchers. Thus other linguists who wish to check a particular linguistic hypothesis against information about the language, are hampered by the lack of published material, of handbooks, grammars, thesauri, dictionaries, texts, dialect surveys, and the like. Instead an investigator may have access only to published accounts of fragments of the grammar, a vocabulary or two of a few thousand words, a descriptive grammatical sketch, and perhaps a body of texts. To a large extent the linguist must take on trust the (sometimes contradictory) accounts of a few field-workers. While Warlpiri does not avoid posing problems for the researcher of the kind described, the situation is exceptionally good in a number of respects, as I now outline.

Warlpiri is one of a handful of Australian languages which may be



said to be in a third generation of description and research. Pioneering work was done by Capell, Reece and Jagst. Since 1959, Hale, in the course of his prolific and sensitive documentation of so many Australian languages, came to collect the most information on Warlpiri. Virtually all his field notes and tapes are accessible at the Australian Institute of Aboriginal Studies and at Yuendumu, as well as I.I.T. Furthermore Hale has published a number of detailed analyses of aspects of Warlpiri grammar and other compilations circulated in mimeograph or lodged in typescript at A.I.A.S. and Yuendumu (see the Bibliography, Part I). Hale's data is as strong in quality as it is in quantity, as attested by his published analyses and his fluent command of the spoken language.

The "third generation" involves the Bilingual Education Programme (in which Laughren is employed) based at Yuendumu, and now extended to Willowra. Many primers and readers have been published since 1974 and since mid-1978 a monthly bilingual newsletter Junga Yimi. The Warlpiri dictionary file, with 1979 copy lodged at A.I.A.S., is continually added to at Yuendumu, and includes many monolingual entries. This period has also seen the beginnings of written work about their language by Warlpiris.

All the above data has been available to me in the compilation of this work, and, more importantly, I have had constant guidance to it from Hale (either in person or through his manuscripts and excerpts) and, especially in 1980, Laughren. These two are the source of a lot of the substantive generalisations about Warlpiri that I make use of. From my reading of some of the Warlpiri texts, and my own limited contact with Warlpiris, I have been alert for examples that test these generalisations, and have rarely, if ever, found them misleading. A large number of Hale's and Laughren's insights I have not checked independently, but it is not practicable to indicate below which points I have personally corroborated. The generalisations based on lexical data (chapters 2-4, 6) I have checked in detail in my own study of the dictionary, but with those involving sentence and text data I rely more on Hale and Laughren.

In a sense, then, the data for this work is not so much the mass of Warlpiri expressions and texts on record, but rather at one remove: the large number of specific generalisations about Warlpiri that have been mentioned in my discussions with Hale, and , in 1980, Laughren. However,

## 1.2 NOTATION

Warlpiri orthography has been standardised for the past five years or so, the complete system is included in 3.1. It may be helpful to indicate some correspondences with orthographic symbols used in earlier work:

standard orthography	Hale, 1959-66	Hale 1967-1973, 1976c
rr	r	r
rd	ṛ	ḍ
r	R	ṛ
j	t <sup>y</sup> , tj	tj
ny <sup>1</sup>	n <sup>y</sup> , nj	nj
ly	l <sup>y</sup> , lj	lj

Furthermore, t, n and l are indicated by digraphs in the standard orthography, as rt, rn and rl respectively (and simply t, n and l word-initially -- see 3.2(2), note 2), and ŋ is written ng.

Here and there I have indicated dialectal variation of a form by adding in parentheses a letter indicating the rough dialect group that the form is restricted to. The dialect letters are taken from place names associated with each area, and are not used beyond this work. Their rough geographical basis is as follows:

- Y "Yuendumu"; south-western part of Warlpiri area.
- W "Willowra, Wirliyajarrayi"; on the Lander River; central part of Warlpiri area.
- H "Hanson"; traditionally on the Hanson River, and now mainly at Warrabri (Ali-Curung); eastern part of Warlpiri area.
- L "Lajamanu", (Hooker Creek); northern part of Warlpiri area.

Analytical notation employed in this work is given at various points: abbreviations for parts of speech, and category features - 2.1, 5.3, 5.4.1.1; morpheme contexts - 2.2; phonological features - 3.1; harmony autosegments - 3.5; metrical trees - 3.6; case labels - 6; semantic expressions - 7.2.

---

<sup>1</sup>Before j, ny is often written simply as n; the distinction is of minor importance, if phonological at all. It (and l) do not occur before y.

### 1.3 OVERVIEW

The topics of Warlpiri grammar treated in this work are from a number of autonomous components of the grammar, but are conceived of within a unified model. Properties of the model emerge in the discussion of particular topics, and are presented in broad terms in 5.2. Here I do not so much discuss the grammatical model, as survey certain analytical decisions with many ramifications throughout the account.

The morphology of Warlpiri, represented for all words but Verbs and the Auxiliary as a labelled bracketing, is presented in detail because the other components of the grammar rely heavily on it:

(i) the morpheme structure conditions ("phonotactics") vary somewhat for certain differing morpheme classes, but this is by no means unusual;

(ii) prosodic phonology (vowel harmony, 3.5, and stress, 3.6) operates in morphologically defined domains (3.5.3), and initial placement of stress occurs in "root" morphemes (not, as in many languages with stress assigned by rule, within the word);

(iii) most significantly, the syntax of Warlpiri sentences is presented in a manner which shows the fundamental role of inflexional morphology. No syntactic categories are needed apart from "projections" of parts of speech which are defined in word-formation terms. Furthermore, semantic interpretation, at least in its gross sense of the correct assignment of arguments to argument positions, is governed primarily by various specialised inflexions (the "Argument" cases Ergative and Dative; the Complementisers; and the Auxiliary), none of which are part of verbal inflexional. Contrasted with the importance of inflexion is the quite minor role (certainly from a typological viewpoint) accorded word-order, and the "flat" syntactic structures.

The continual reference to morphology is achieved without postulating any "zero morphemes", which are often employed in analyses of similar languages to Warlpiri. For instance, the unmarked "Absolutive" case is ascribed here only to the level of "linked" case-labels, separate from morphology -- see Chapter 6. And a "zero" Auxiliary base is here regarded as truly missing, as are "missing noun phrases" in the account of the syntax. I have perhaps recognised an unusual number of "homophonous" suffixes, however -- on the assumption that future research will find it easier to identify two "homophonous" suffixes, than to disentangled two

in a treatment where they are taken as identical.

In accounting for Warlpiri syntactic patterns, little evidence is found for a level of "grammatical relations" distinct from a level of "thematic roles" (on the one hand) or from morphology (on the other). Some other syntactic entities proposed for other languages but lacking in Warlpiri are mentioned in 5.5.

## CHAPTER 2: MORPHOLOGY AND WORD-FORMATION

In this chapter, I present the lexical categories, major and minor, of Warlpiri, and detail the general internal structure of words. Enclitics are incorporated into the account in 2.7. The phonotactics, or morpheme structure conditions, are treated in 3.2, and the special properties of reduplication are gathered to form the account in chapter 4. This chapter includes all affixal and enclitic morphemes of Warlpiri that have come to my attention. They are listed at various points according to their morphological properties, rather than their meaning or syntactic function, yet there is a fairly close correspondence among the different types of properties. That is, the morphologically-based groupings have a high degree of semantic unity, and of syntactic similarity, as will be seen in later chapters.

## 2.1 PARTS OF SPEECH

The Warlpiri parts of speech are the lexical categories in terms of which certain morphological and phonological generalisations are stated, and which also function as syntactic categories, used to label syntactic nodes with categorial information ("categorial signatures").

The approach to Warlpiri syntax developed in later chapters makes the basic assumption that sentences are generated simply as arbitrary  $s$  rings of words. "Word" is used here in a sense which corresponds closely to the intuitive concept. In particular, words are assumed to be generated complete with all inflexion (tense/aspect on verbs, case and complementizer on nominals). I also generate words with enclitics attached, as will be seen in 2.7. This account avoids the use of syntactic rules which, for instance, "assign" case inflexions. Hence, it is important to present the processes of word-formation, not only because of their inherent interest for the study of morphological processes, but also to see the range of categorial information available for the syntactic and semantic processes that are investigated later.

The traditional notion of "part of speech" applies to root and stem morphemes. This account extends the notion to derivational and inflexional morphemes, as discussed in 2.2. Thus I use certain parts of speech whose lexical members are all suffixes -- these may combine with stems to form words that are also members of the category to which the suffix belongs. Examples of this are given in the discussion of Case, Complementiser, and Argument.

The following table gives the parts of speech needed in Warlpiri, along with certain "category features" which group the parts of speech into natural classes apparent in word-formation. I also give each part of speech a (capital letter) abbreviation, which is used mainly in the interlinear glosses of Warlpiri expressions.

<u>Part of Speech</u>	<u>Abbreviation</u>	<u>Category Features</u>	
Nominal	N	+N	+C
Infinitive	INF	+N	+V
Verb	V	+V	
Preverb	PVB	+V	
Case	CASE		+C
Complementiser	COMP		+C
	COMP		-C
Argument	ARG		
Modal Particle	MOD		
Conjunction	CONJ		
Auxiliary	AUX		

Unless marked as "+" in the table, the value of a category feature is "-". Thus MOD is [-N,-V,-C], CASE is [-N,-V,+C], and so on.

Clearly I have not provided sufficient category features to allow a unique specification of each part of speech in terms of features alone. The fact is that even if such additional features were assigned, there would be no rule in this account of Warlpiri which would make use of those additional features, so for practical purposes I have no need of them.

The way these categories group together for morphological processes is set forth in 2.3 - 2.7. Here I note the distribution of some other types of property across these categories.

(1) The categories whose members may be said to have argument positions are those which have the "+" value for the feature [N] or [V]. All Verbs and Infinitives, and to an extent Nominals, and some Preverbs, have functional representations with one or more argument positions.

I use the term predicate for the semantic entity which has argument positions.<sup>1</sup> In this I follow the linguistic and logical usage which has grown up over the last century, rather than the (persisting) classical usage which opposes "predicate" to "subject".

The category N includes words which translate into English as adjectives, or even verbs (such as want, know). These words are seen as Warlpiri Nominals that prefer a reading which has an argument position in it, just as a kin-term Nominal, for instance, has argument positions. But these relational and predicational Nominals are lumped together with substantives not only for morphological reasons, but also because this semantic distinction between "substantive" (with "individual" focus) and "adjective" (with predicational focus) is not so clear-cut in Warlpiri as in, say, English. This topic will be taken up in 6.5, and a couple of examples should suffice here. The Nominal pina 'wise, knowing, experienced' has a predicational focus, often best rendered in English with a verb, such as 'know'; and can also be used in an individual rather than a predicational sense in Warlpiri, in which case it might be translated as 'knowledgeable one, wise one'. And conversely, a Nominal such as wirriya '1. boy; 2. male person or animal' has an "individual" focus; and is sometimes used predicationally where it is best translated as 'male' or the like. (Compare English male, which in these terms has predicational focus, and also an individual sense.)

Tense and aspect information is carried primarily in a "bipartite" fashion by the Auxiliary base (2.7.1) and inflexions on the Verb. Of course some Nominals (e.g. time words), Modal Particles, and enclitics may also have this function, which often translates as an English adverb. The Modal Particles, and some enclitics, have a sentence-adverb function, modifying the mood or speech-act force of the sentence.

The Auxiliary also contains enclitics marking the person and number of the "subject" and "object" of the sentence -- these are sometimes called "pronominal clitics", and they carry pronominal information about the (one or two) grammatically prominent arguments of the predicate.

---

<sup>1</sup> This term should not be confused with Predication, a rule of semantic interpretation of the Control type, proposed in 7.3.3. This rule gives one of the indirect modes of association between a nominal expression and a predicate argument position. An English parallel would be the interpretation of sick in John arrived sick by associating sick with the argument position of arrived which John is directly associated with.

(ii) The category of Preverb is perhaps the most diverse of those listed. It does have a reasonably clear morphological characterisation (viz. those words, or compound formatives, which combine with a Verb -- normally immediately preceding the V but sometimes immediately following it -- to give a complex Verb; along with Verbs, they do not take suffixes found on Nominals, and are the only items which may host the directional enclitics (2.7.2).) It appears that any N, CASE or INF is potentially a Preverb for some Verb or Verbs (a phenomenon treated below as "zero-derivation") but there are a large number of Preverbs that are not derived from any other category, and cannot occur without a Verb from a small set selected by the given Preverb. And there are "productive" Preverbs, also not derived from another category, but which may combine with virtually any Verb to produce a uniform semantic modification, such as 'back, return' (pina) or 'again' (yarda): see 2.6.4.1. Certain productive Preverbs may also be seen as having argument positions: an example is kaji 'for (the benefit of)'. This argument position is added to those already in the functional representation of the Verb, and may be evaluated only by a nominal in the Dative case, and so these Preverbs have been dubbed "dative adjunct Preverbs". In short, Preverbs are rather like adverbs, but different enough as a class to warrant a different name.

(iii) The categories Case and Complementiser have a number of members in common, i.e. morphologically identical, but each has some of its own. Syntactic expressions which are members of the Case category are all derived from Nominals; of the Complementiser category from [+N], i.e. Nominals and Infinitives. Members of Case, apart from the case suffixes themselves, include all "Case-marked Nominals" (apart from those, that is, bearing the Ergative and Dative, which receive separate treatment as members of the category Argument). Members of Complementiser are primarily Infinitives bearing a complementiser suffix, and also include Nominals bearing a complementiser. Some members of Case are also noun formatives, i.e. derivational suffixes rather than cases, and are here called "derivational cases". Thus what appears to be a single suffixal morpheme may have up to three different categories of which it is a member: N, CASE and COMP. The formal unity comes from the single lexical entry, with perhaps more than one sub-entry, accorded such a morpheme.



(iv) Argument is the category whose members are marked for the Ergative or Dative case, the two marked "grammatical" cases of Warlpiri. Apart from the two root members of this category, viz. the two suffixes themselves, all members of the Argument category are derived from members of N, CASE or COMP -- to be precise, from [+C] items. (Hence the division of the COMP category in the above list -- the [-C] members do not take an Ergative or Dative.) I have chosen the name "Argument" for this category since interpretation of a member of this category always involves association of it with an argument position in the functional representation of a predicate, whereas interpretation of a member of the Case category typically involves an addition to the functional structure of the whole sentence. Thus the Argument vs. Case distinction is paralleled by a distinction in the Linking Rules (Chapter 6) between grammatical linking and semantic linking (after Ostler, 1979). But the distinction is also put to use in word-formation, as shall soon be seen.

No "Absolutive" case is recognised morphologically -- if it were, it would have to be a "zero morpheme",  $\emptyset$ . In this account, the term Absolutive is reserved as a label assigned by the Linking Rules to one (perhaps in some verbs, two) argument position of most predicates, and made use of by rules of semantic interpretation, principally Evaluation (7.5).

(v) The Auxiliary, and some Modal Particles, show sentence-clitic behaviour in that they have a preferred position in the sentence. This is either initially, or else in "second" (or "Wackernagel's") position, after the first "constituent" of the sentence: see 5.6. The Auxiliary is treated as a word, but depending on its phonological make-up it may be enclitic to the word it follows. The Auxiliary is the only word which cannot host enclitics, and Modal Particles do so rather rarely. The two Conjunctions (kala 'but', manu/kapi 'and, (inclusive) or') may also occur in "second position" when connecting two sentences, though are usually initial (in the second sentence). The latter, because of its meaning, has the additional property that its scope may extend over two adjacent nominally-based expressions within a sentence. Further, when the Conjunctions are sentence-initial, they appear not to count for the determination of "second position".

The reader will have noticed that I propose to use certain relations of derivation between some of the parts of speech, e.g. CASE from N, INF from V, ARG from [+C]. On the other hand, some parts of speech are unable to receive (further) inflexions. Such categories are those with all three category features negative, i.e. [-N,-V,-C] (which, incidentally, provides a property shared by Arguments and the "minor" parts of speech (MOD, CONJ, AUX), which have in traditional terms little to do with each other.) Verbs are listed lexically with their inflected forms, without the roots bearing a category by themselves, and the only further inflexion they may take are the directional enclitics, and, as for any non-AUX category, the true enclitics.

## 2.2 STRUCTURE OF THE LEXICON

There is general agreement that the primary unit of the lexicon is the "lexical entry", and that the range of information contained in a lexical entry includes the following: (cf. Fillmore, 1971:370)

- the head of the entry, specifying the root(s) and stem(s)
- the phonological representation (underlying form)
- any necessary phonological or morphological diacritics, marking exceptional items
- lexical category
- a semantic representation of some sort -- here I follow Ostler, 1979 and refer to the Functional Representation (or, for a predicate, the argument structure) along with any Linking Specifications it bears (i.e. diacritics for irregular linking of participant roles with cases)
- subcategorisation frame, or (after Ostler, 1979) the "general syntactic context"

Differences between various theories of the lexicon have to do in the main with what items have their own lexical entry (only roots and affixes? all stems and affixes? all inflected words?), and with what devices are used to relate items with common elements (word-formation rules? diacritic "pointers"?) including the ways of treating allomorphy (by morpho-phonological rules? morpho-lexical rules?).

In this work, I adopt a (slightly modified) model developed by Lieber, 1980 for the inflexional morphology of English, German, and

Latin. That model is readily applicable to the morphology of Warlpiri since, like the languages just mentioned, Warlpiri's morphology is almost all of the "concatenative" type. In fact, Warlpiri's morphology is more clearly the "stringing together" of segmentally-constituted and invariant root and affix morphemes than is the morphology of the languages considered by Lieber.

The repository of lexical entries (of the sort mentioned above) is termed the "permanent lexicon" (M. Allen, Lieber) or "dictionary". But there are many "lexical items", i.e. words, which do not have a lexical entry, but rather are formed from more than one lexical entry by word-formation. Inflexional processes are the clearest examples of word-formation. The extended sense of "lexicon" includes all inflected words, in fact all words that are well-formed according to the rules of word-formation. A lexical item formed by the rules of word-formation inherits most of the properties of the root(s) and/or stem(s) which constitute it -- most clearly, the phonological and semantic properties. The lexical category, and general syntactic context of the complex word is also predictable, and unless otherwise specified, any diacritics are also inherited by the complex word.

A well-formed word is any product of word-formation. Its hallmark in this account is the bearing of a pair of square brackets labelled with a lexical category. Thus

$[N X]_N$ , commonly abbreviated as  $[X]_N$

is a word which a member of the category N(ominal), whatever the internal content of X, as long as X is well-formed by the word-formation rules. The model of the lexicon used here allows the making of the generalisations and distinctions that Warlpiri calls for, as I see it. For instance, the formation of Warlpiri Nominal stems has a different character from the formation of complex Verbs, as is summarised in the following table.

<u>Nominals</u>	<u>Verbs</u>
agglutinating morphology	inflexional morphology
stems occur uninflected	themes require inflexion
no "declensions"	5 "conjugations"
thousands of roots	just over a hundred roots
compounds: $[N N]_N$ -inflexion	PVB-[V-inflexion] <sub>V</sub>

This distinction between N and V is reflected in this account by the device of listing a nominal stem as a lexical entry without its inflexions, and at the same time listing verb stems with a conjugational diacritic which requires the addition of an inflexion with matching diacritic to make a well-formed word. Thus, a typical nominal lexical entry is:

[maliki]<sub>N</sub> 'dog'

while a typical verbal stem has a lexical entry like:

<paka, V2> 'hit, strike' .

Then, using the diacritics V1, V2, V3, V4, V5 encoding conjugational allomorphy, the inflected verb word

[paka-ka]<sub>V</sub> 'hit-Imperative'

will be well-formed, because the root can combine with the inflexion which has a lexical entry such as:

<ya, V1; ka, V2; ngka, V3; nja, V4; nta, V5> 'Imperative'  
Context frame: [X---]<sub>V</sub>

The lack of category-labelled brackets around paka prevents it from existing as a word by itself.

An inflected form of a nominal is derived by combining two lexical entries, rather like the matching of the verbal stem and affix entries just exemplified. The constraints on combination are somewhat looser, however. Combination of two lexical entries is in general possible if the two have "matching" category labels, so that a typical suffixal element has an entry such as:

] <sub>N</sub> parnta ]<sub>N</sub> 'having, Propriative'

wherein the "outward-facing" category bracket acts as a context specifier, requiring that this element must attach to a member of the category N. The "inward-facing" bracket (on the right in this example, and indeed for any suffix) specifies the category to which the combination belongs. Thus, in combination with the nominal entry already given, this suffix shows up as:

[[maliki]<sub>N</sub> parnta]<sub>N</sub> 'having dog' .

Thus, I am writing ] <sub>N</sub> parnta ]<sub>N</sub> as a variant of what Lieber, 1980 would

parnta / ]<sub>N</sub>---} <sub>N</sub>

and I use whichever of these notations is convenient in a given context. Note that the outer left bracket in a form like [[maliki]parnta] needs to be added -- I assume a convention with this effect. The convention on completion of bracketing provides a bracket which is paired with the outer bracket added by an affix.

I should point out that, while the distinction I have drawn here between nominal and verbal inflexion is generally valid, there are respects in which the distinction breaks down.

First, there are a number of "nominal formatives" -- elements which have historical sources perhaps as enclitics or compound-elements, but which have a quite restricted distribution in modern Warlpiri. Since they do not combine freely with all, or most, nominals, they require listing as part of a stem, in much the same way that verbal inflexion is treated. See the examples -pari, -nji/-nju, -ku/-ki and -pa in 2.3.1.3 below. In these nominals there is no need to recognise any internal boundary for, say, the purpose of assigning stress, though there is the need to relate such nominals to others with the same root. This can be done by having the lexical entry with the root given first, even though it may not bear labelled brackets. For example:

<narntirn, [narntirn-pari]<sub>N</sub>> 'bent, crooked'

may by this device be related to

<narntirn, [narntirn-ki]<sub>PVB</sub>jarri, V1> 'become bent, stooped'

and to

<narntirn, [narntirn]<sub>PVB</sub>wanti, V1> 'to be stooped over' .

To some extent, inflected verbs receive a treatment similar to this. But there is a complication, at least in the application of the stress rules. In 3.6.3 a rule is proposed which assigns binary feet left-to-right within morphemes. In 3.6.6.2 I discuss the extent to which an inflected verb is a single "morpheme" for the application of binary-foot placement, and reach an intermediate conclusion, viz. that certain inflexional syllables may survive the foot-placement rule without being made a part of any foot, a possibility not allowed for any other polysyllabic

domains of foot-placement. And two verbal inflections (nja which forms Infinitives, and nji which forms Inceptive stems) are unlike any other inflexional monosyllabic morphemes in that they attract (secondary) stress.

### 2.3 SUFFIXES

This section gives a comprehensive listing of the derivational and inflexional affixes of Warlpiri (all of them suffixes), arranged according to their "subcategorization frames", which show both the stems to which the affix may attach, and the category of stem thus formed.

#### 2.3.1 N FORMATIVES

These are the suffixes which form nominal stems, N. The majority of these form an N from an N, and are listed first, followed by the suffixes which form N's from members of other categories.

##### 2.3.1.1 N FROM N

The following suffixes have the context

$]_{N} \text{---} ]_{N}$  :

kangukangu	'Distributive Proprietary, each having'
kanjayi	'far, of comparable distance or length' (see commentary in Granites, 1976:11)
kari	'another, one of a pair'; kariyinyanu (see 7.3)
ngarna	} 'denizen of [ecological niche]'
ngawurrpa	
nyangu	'Possessive' (on pronouns only; cf. <u>kurlangu</u> )
pardu	'Diminutive (of affection)'
witawangu	'very'
wardingki	} 'native of, resident of [place]'
malu	
piridinypa	'Definite Specific, the one which is' (see 6.3.1)

It is possible that some of these suffixes are also Case-like, in that they may participate in complex nominal labelling (5.4.1) and have scope over an N to the left of the N to which they are suffixed. In fact, it is known that an expression such as

nguru nyampu-wardingki  
country this -resident

is interpretable as

'resident of this country'

but whether this is generally so I am not sure.

The following morphemes are doubly-classified, in that they have the possibility of being enclitics (following any category) as well as the possibility of preceding a case suffix. Thus they are given the contexts:

$]_{N} \text{----} ]_{N}$

$] \text{----} ]$  (for which see 2.7).

katu	'it would be better, Comparative'
mipa	'only'
ngarrara	'Superlative'
rlangu	} 'for example, also, even'
malku	
nyayirni-nyarrirni(H?)	'very'
pinki	'and the like, and its ilk'
puka	} 'only'
pinang(W)	

Another double-classification, central to Warlpiri syntax, is of those suffixes which have the following two contexts:

$]_{N} \text{----} ]_{N}$

$]_{N} \text{----} ]_{\text{CASE}}$

These suffixes have been termed "derivational cases" (Hale, 1979:68) because they may simultaneously exhibit properties of derivational suffixes, and of cases, an aspect taken up in 5.4.1. The morphemes that exhibit these properties may include some of those classified simply as  $]_{N} \text{---} ]_{N}$  above, but certainly includes the following:

kurlu	} 'Propriative, having'
parnta	
ku-rlangu	'Possessive' (except on pronouns, cf. nyangu)
jangka	} 'Elativ' (see also 2.3.2)
warnu	

wangu 'without, Privative'  
 piya 'like, similar to'

and the two Number suffixes:

jarra 'Dual, two'  
 patu 'Definite plural, Lesser plural'  
 (sometimes termed "Paucal")

and perhaps rra 'Greater plural (on definite determiners only)',  
 discussed along with some other properties of the subcategory of Number  
 in 5.4.1.1.

Furthermore, the cardinal directions ('north', 'south', 'east',  
 'west', 'up', 'down') have an elaborate and specialised derivational  
 subsystem, which is given a detailed treatment in Laughren, 1978, and from  
 which I quote just the form of the suffixes involved:

-mpayi	'far'	-nginti	'to the side of'
-mparra	'along the side, across'	-purda	'in the direction of'
-rni	'hither'	-kari	'in the direction of'
-rra	'towards, thither'	-nyarra	[allmorph of <u>-mparra</u> ]
-karrkarri	'further'		

The kinship terminology is another elaborated domain, with many more  
 such specialised suffixes and stems, described in part by Hale, 1972, and  
 in more detail in Laughren, forthcoming. Some of the suffixes in the domain  
 of kinship deserve a brief mention:

[[ K ]<sub>N</sub>nyanu]<sub>N</sub> 'X's K' (K a kin-term, X an anaphoric antecedent)  
 [[ K ]<sub>N</sub>puraji]<sub>N</sub> 'your K' ,

and the apparently doubly-classified suffixes

ku-palangu	'ascending generation kinsman of'
ku-purdangka	}'same-generation kinsman of'
ku-pirdangka	

(the normal Possessive is used for the  
 descending generation kinsmen)

which pattern with the "derivational cases" given above. In addition,  
 there is:



$]_{N}ku\text{-ngarduyu}]_{N}$  'group of same age set (usually humans, sometimes animals), of given totem'

which has also been recorded as  $]_{N}rla\text{-ngarduyu}]_{N}$ , i.e. apparently built on the Locative (2.3.2) rather than the Dative (2.3.4); and the compound type

$]_{N}ku [K]_{N}nyanu]_{N}$  'the K of'

which may prove to be analysable as the ARG-N compound

$[ [ ]_{N}ku]_{ARG} - [[K]_{N}nyanu]_{N} ]_{N}$ .

### 2.3.1.2 N FROM INFINITIVES

The following suffixes have context

$]_{INF}----]_{N}$  :

$ku\text{-}langu$  'instrument or place for'

$parnta$   
 $palka (W,H)$  } 'Potential, one able to, characterised by'

$panu (Y)$   
 $witawangu$  } 'one who engages excessively in'

and the meaning of each of these suffixes is filled out with the sense of a gerund based on the verbal stem of the Infinitive, thus:

$parnti\text{-}nya\text{-}nja\text{-}kurlangu$   
smell-perceive-INF-  
'instrument for smelling, i.e. nose'

### 2.3.1.3 UNPRODUCTIVE N FORMATIVES

There are two sorts of N formative which combine with a limited number of N-roots: (1) those which occur on roots which are also N words, and (2) those which occur on roots which are not words in their own right. They have in common that they are found immediately after simple roots, never on complex stems, and that the range of roots with which they combine is not completely predictable. They are considered in turn:

(1)  
(a) jardu 'in exchange for', as in:

$karnta\text{-}jardu$	, $ngangkayi\text{-}jardu$ ,	$jawa\text{-}jardu$
woman-	healing-	? -
		'murderer'

(b) jarlu 'very', as in:

wiri-jarlu,	panu-jarlu,	wirriya-jarlu,
big-	many-	male-
'very big'	'very many'	'big male'
wakurlu-jarlu,	jangarnka-jarlu	
headhair-	beard-	
'hairy'	'with a big beard'	

Note the other possible occurrence of this morpheme, in

jarlupatu 'elders, old men; authorities'

(cf. -patu 'Lesser plural').

(c) marri 'expert hunter of', as in:

marlu-marri,	mala-marri
kangaroo-	W. hare wallaby-
'expert hunter	'expert game hunter'
of kangaroos'	

(d) marntu 'place with plentiful supply of'

miyi-marntu,	kuyu-marntu,	jiwirri-marntu,	warlu-marntu
food-	game-	kindling-	firewood-

(e) ngirninypa 'group of' (Hale, 1966:1293,1300,1303)

yaparranji-ngirninypa,	jilkaja-ngirninypa
youths-	tour undertaken by initiands-

These formatives are restricted pretty much to occurrence with the roots that have been cited. It is possible that they are historically N-N compounds, the second N of which is no longer found elsewhere in the language. Certainly the formatives have the shape, phonologically, of Nominals, unlike the formatives to be listed in (ii), a couple of which are monosyllabic, and one of which begins with a consonant cluster.

(ii)

(a) pari

kuurl-pari	'constricted'
liirl-pari	'shiny white'
lakarn-pari	'flaked, peeling'
muly-pari	'footprint'
rdupul-pari	'prominent hillock'
narntirn-pari	'bent, crooked, stooped'

(b) ku ~ ki (meaningless augment, on consonant-final roots)

kirtirl-ki 'curved'  
 (as in the term jaka-kirtirlki 'steatopygic')  
 narntirn-ki 'bent, stooped'

There are few roots with this formative that may be positively identified, since the roots do not turn up in other contexts. But there are some Preverbs denoting shape or motion which may involve this formative, at least historically:

jalpanyku 'with head down'  
 jiwirlki-jiwirlki 'with appendage (e.g. tail) bouncing'  
 mulunyku 'with legs together'  
 wararrku 'meandering'

Of these, the second and fourth have so far been recorded only with the Verb parnka-mi 'to run', and their meaning has been abstracted from the compounded meaning, such as:

wararrku parnka-mi '1. to slither -- of snake; 2. to meander -- of creek'

Note that this formative shows vowel assimilation of a type found in modern Warlpiri vowel harmony (3.5 below).

(c) pa (meaningless augment, on consonant-final roots)

This formative is to be distinguished from others in this section in that it occurs with many more roots, and may be semi-productive. In the Western Desert languages spoken to the west of Warlpiri, it is fully productive (Hansen & Hansen, 1978:39,53), in that further suffixes replace pa rather than follow it.

Many Nominal roots in modern Warlpiri end in pa, but, as for ku, the formative has become part of the root. Examples include

jungunypa 'mouse sp.'  
 jurnarrpa 'equipment, clothes, supplies'  
 juulypa 'green shoots of young spinifex'

and many more; see also examples with reduplication in 4.1 below.

With some Preverbs, the augmented form with pa alternates with the unaugmented form, as introduced by the rule of 2.6.5. An example is:

[liwarr] <sub>PVB</sub> pi-nyi	'to miss it, long for it'
[liwarrpa] <sub>PVB</sub> pi-nyi	'to miss him, worry about him'

where the latter, augmented, version is the one that must be used when the Preverb is separated from its Verb root (as it must be when directional enclitics, or the Auxiliary clitic, intervene). The correct structure for the former, unaugmented Preverb, in such a combination, may prove to be, in formal terms:

<liwarr, [liwarr[pi-nyi]<sub>V</sub>]<sub>V</sub>>

in contrast to the latter, augmented Preverb in the combination:

<liwarr, [[liwarrpa]<sub>PVB</sub>[pi-nyi]<sub>V</sub>]<sub>V</sub>> ,

but that possibility is not the one explored in this work.

Another alternation involving pa is one such as:

wuulypari	'dark -- of night, evening'
wuulywuulypa	'dark'
wuuly-kiji-rni	'to envelop, enshroud -- of darkness'
	(cf. <u>kiji-rni</u> 'to throw, cause to fall')

See also the account of the morpheme structure conditions, 3.2, for further commentary on this formative.

(d) nji ~ nju 'pejoratively characterised by'

<u>Stem</u>	<u>Root</u>
kuranji 'larrikin'	kura 'sexual activity'
laninji 'coward'	lani 'afraid'
marinji 'sadness, grief' (L)	mari 'sad; sadness'
mururrunju 'comical fellow'	mururru 'mirth'
purunju 'theft, thief'	puru 'theft, removal'
purunjunju 'thief'	
ruyunju 'liar'	
warlkanji 'liar'	warlka 'lie, pretense, false'

This formative shows vowel assimilation of a type found only in some dialects of modern Warlpiri with respect to productive affixes -- see 3.4 below.

Another Nominal which falls in this class is:

tirinji 'sponging, begging, bludging'

which is by no means clearly related to the modern root:

tiri 'red',

although the notion of pejorative characterisation is still associated here with tirinji, as with the other forms in nji.

It might be noted, to close this survey of unproductive N-formatives, that there are instances of an otherwise productive suffix, one of those listed in 2.3.1.1 above, having acquired special meanings on certain roots, which need a special lexical entry. Thus, consider these Nominals:

tiri-pardu 'joey (baby kangaroo), at hairless stage'

(cf. tiri 'red', pardu 'Diminutive')

ngarnta-kurlu 'modern knife'

(cf. ngarnta 'knife handle')

karlangu-jarra-parnta 'scorpion'

(cf. karlangu 'digging stick', jarra 'Dual',

parnta 'Propriative')

#### 2.3.1.4 N FROM VERBS

Most transitive verb stems may form a Nomic Agentive nominal, homophonous with the Past tense (except for V1 verbs, which employ the ending ngu, the V3 Past tense). Consistent with the treatment accorded other verbal inflections, these Nominals have a lexical entry such as:

<nga, V4, [nga-rnu]<sub>N</sub>> 'eater'

derivable from the inflexion entry:

<ngu, V1; rnu, V2; ngu, V3; rnu, V4; nu, V5> 'Nomic Agentive'

Context frame: [X---]<sub>N</sub> .

These deverbal Nominals are almost always found compounded with a preceding Nominal, as in:

[[marna]<sub>N</sub>[nga-rnu]<sub>N</sub>]<sub>N</sub> 'grass eater'

There are also examples compounded with Case, as in:

[[[Kanaji]<sub>N</sub>ngirli]<sub>CASE</sub>[ya-nu]<sub>N</sub>]<sub>N</sub> '(name of legendary ogress)  
(place)-Erelative- go-Nomic

and the elicited example (Hale, 1967:14):

[[[ngulya]<sub>N</sub>ngka]<sub>CASE</sub>[nyina-ngu]<sub>N</sub>]<sub>N</sub> 'hole dweller'  
hole- Locative - sit-Nomic

which last two examples also involve an intransitive verb. A further type, which may well be quite marginal, shows the compounding of a Nomic Agentive with an Argument:

[[[wawirri]<sub>N</sub>ki]<sub>ARG</sub>[wurru[ka-ngu]<sub>N</sub>]<sub>N</sub>]<sub>N</sub> 'kangaroo stalker'  
kangaroo-Dative- stalk-Nomic

This example illustrates another possible complexity, namely the derivation of a Nomic Agentive from a compound Verb, i.e. one involving a Preverb, in this example the unproductive Preverb wurru. The labelled bracketing which I have assigned to the complex Nomic Agentive here must be regarded as quite speculative, and merely that predicted by the word-formation rules I have set up elsewhere. On the other hand, I know of no evidence counting against the structure I have here proposed. But the lack of other examples and the elicited nature of this example calls for caution. For some further remarks on these constructions, see Hale, 1967:11-15.

### 2.3.2 CASE FORMATIVES

I reserve the term Case for the suffixes presented in this section, and for any nominal inflected with these suffixes. I do not mean to include the Ergative and Dative suffixes, which are also, in traditional terms, "cases", for these two suffixes call for special treatment in Warlpiri.

The following suffixes have the context

]<sub>N</sub>----]<sub>CASE</sub> :

(1) rla ~ ngka 'Locative; at, in, on'

This suffix has an allomorphy exactly parallel to that of the Ergative, the details of which are given in 2.3.4: rla is the allomorphy on all stems except for (all but a handful of) disyllabic N roots (there being no monosyllabic N roots).

There is a Case suffix built on the Locative, viz.

rla-jinta ~ ngka-jinta 'Comitative; with, accompanying'

containing a boundary (indicated by "-") relevant for stress placement. See Granites, 1976:10 for illustration of its meaning, which focusses

on "accompaniment", compared with the "having" focus of the Propriative <sup>31</sup>  
kurlu and parnta, 2.3.1.1 above.

(ii) kurra 'Allative; to, toward, up to, into, onto'  
purda 'towards' (only with directions, and the interrogative  
nyarrpara and demonstrative kuja)

(iii) ngurlu 'Elative; motion or separation from'  
and also the two Elatives listed in 2.3.1.1 above:

jangka 'Elative of origin, source, cause; after'

warnu 'Elative of source; after; a subset of'

(iv) wana 'Perlative; along'

wana-wana '1. Perlative, along, about; 2. in exchange for'

The semantics of these spatial cases, particularly the first  
Case given in each of (i) - (iv), is discussed in detail by Hale,  
1978:57-82. He justifies the following semantic grouping of these  
Cases, all seen as specifying a type of "co-incidentence":

central	terminal
(i), (iv)	<u>ad quem</u> (ii)
	<u>a quo</u> (iii)

These semantic distinctions may be seen as recurring, albeit more  
abstractly, in other parts of Warlpiri grammar: the directional enclitics,  
the Infinitive Complementiser system, the finite adjoined clause comple-  
mentisers, and the tense/aspect system. (Hale, "Coincidence: a Warlpiri  
semantic category", talk delivered October 30th 1978 and May 7th 1980).

In addition to the "pure" cases that have just been presented, the  
"derivational cases" of 2.3.1.1 share the context ]<sub>N</sub>----] CASE.

### 2.3.3 COMPLEMENTISER FORMATIVES

The suffixes presented in this section have the context

] [+N] ---- ]<sub>COMP</sub>

That is, these suffixes occur on Nominals, and on Infinitives, but  
cannot follow a Case suffix (nor an Argument, i.e. Ergative and Dative).  
A number of these suffixes "have homophonous partners" (Hale, 1978:82) among  
the Case suffixes listed in 2.3.2, but

"the question as to whether the homophony corresponds to a real relationship in the synchronic grammar of Warlpiri" (ibid.) is a knotty one. Here, I take the conservative approach (and Hale's lead) in not identifying the homophonous Case and Complementiser suffixes, but I unify them to the extent of providing the "same morpheme" with a variety of context frames. Their intimate connexion arises more forcefully in the investigation of their semantic properties, and in historical reconstruction -- for which see Austin, 1980, for a discussion of bivalent Case and Complementiser in Australian areal perspective.

Morphologically, the Complementisers are subclassified as to whether they occur with an immediately following Ergative or Dative suffix. Those that have this option receive the category feature [+C], and those that cannot be further inflected are marked [-C].

### 2.3.3.1 [+C] COMPLEMENTISERS

karra	'Proximate (some speakers); general contemporaneous (other speakers)'
kurra	'Objective' <sup>2</sup>
ku-ngarnti	'Preparative Purposive'
ku-purda	'Desiderative Purposive'
warnu	'Resultative, Perfective Relative'
jangka	(of limited occurrence; same function as <u>warnu</u> )
wangu	'Negative'

### 2.3.3.2 [-C] COMPLEMENTISERS

rla-jinta ~ ngka-jinta	'Proximate Reflexive Accidental'
rla ~ ngka	'Proximate Sequential'
rlarni ~ ngkarni	'Pure Obviative'
puru	'Concurrent'
ku	'Purposive'
] <sub>INF</sub> ku-jaku ] <sub>COMP</sub>	} 'Evitative, Negative Purposive, Admonitive'
] <sub>N</sub> kujaku ] <sub>COMP</sub>	
rlu	'Proximate Volitional' (restricted usage)
] <sub>N</sub> karda ] <sub>COMP</sub>	'Stative Purposive' (not found on Infinitives)

<sup>2</sup> Also recorded on infinitives of verbs of directional motion to express an intention to begin going, and in this usage perhaps related to the Purposive complementizer ku. See Hale, 1978:101.



Those suffixes showing the rla ~ ngka allomorphy follow the same<sup>33</sup> rule of allomorphy as mentioned in 2.3.2(i) for the Locative -- see 2.3.4 below also.

The suffixes listed as bipartite are regarded as such by the stress rules. This is why the Evitative complementiser is given a double entry, for it exhibits the bipartite stress pattern only when suffixed to Infinitives, not when suffixed to Nominals.

The semantics of all these Complementisers is exemplified and discussed by Hale, 1978:90-129, and, for those participating in the obviation system, in 7.3.1 below. The Evitative is the name (following Jeffrey Heath) accorded to what has been called the "Fear" case, often found in Australian languages.

Another Complementiser may be:

ngu 'Resultative'

exemplified in sentences (25,26) in 4.2(iii), but of restricted usage, and not yet observed to be [+C], or on Nominals.

The [-C] classification of the Complementiser rlarni requires a qualification:

Where the complement is construed with an adjunct dative, it is possible to inflect it to agree in dative case therewith, though this is seldom done in normal speech. (Hale, 1978:111)

#### 2.3.4 ARGUMENT FORMATIVES

I use the term Argument in a specialised sense, to refer to a nominal or complementiser-bearing infinitive inflected with the Ergative or Dative case. Strictly, I reserve the term Case for the "semantic" cases of 2.3.2 (and thus distinguish between the word written with the initial letter in upper versus lower case). The "grammatical" cases of Warlpiri are not, in the sense I use the term, Cases, but rather are Arguments. This distinction is needed in word-formation, and in syntax.

The following two suffixes have the context

$]_{[+C] \text{---}}]_{\text{ARG}}$  :

(i) rlu ~ ngku 'Ergative'

(ii) ku 'Dative' .

The Ergative, (i), shows the allomorphy mentioned above at 2.3.2(ii) for the Locative and Comitative, and for certain Complementizers, 2.3.3.2. This rule of allomorphy may be stated:

$$\underline{rl} \implies \underline{ngk} \quad / \quad [ [CVC.V ]_N \text{---} X ]_{[-N]} .$$

The velar-initial allomorph occurs only with disyllabic N's, and all other stems (including disyllabic Infinitives) take the lateral-initial allomorph. Strictly speaking, the velar-initial allomorph is restricted to bimoric N stems, as a long vowel "counts as two syllables" for this rule of allomorphy: ngurrpa-ngku 'unknowing-Erg' but nguurpa-rlu 'throat-Erg'. Thus, as is reflected in the orthography, long vowels count as "VV" for the application of the above rule of allomorphy (and see 3.6.3).

Further, a small class of common N roots are marked as exceptions to the rule of allomorphy, for they take only the lateral-initial allomorph:

- |   |                    |
|---|--------------------|
| nyampu 'this'                             | kuja 'thus'        |
| yali 'that removed'                       | nyiya              |
| yinya 'that beyond'                       | nyayi (H) } 'what' |
| mirni 'that removed, indefinite location' | nyarrpa 'how'      |
| nyana (H) 'who'                           |                    |

Not all "determiner" Nominals are on this list -- ngana 'who', and ngali 'we Dual Exclusive' take the velar-initial allomorph.

See Hale, 1976d for hints toward the historical origin of the rule.

ARGUMENT FUNCTIONS

The Ergative and Dative function as morphological markings relating any word bearing them to a matching argument position. Predicate argument positions are assumed to be "linked" to the abstract case labels ERG, DAT, ABS, etc. -- the array of such pairings is the "linking register" of the predicate, for details of which see Chapter 6. An argument position may be filled, or "Evaluated", by a nominal marked with a matching Argument inflexion. In traditional terms, an Ergative case-marked nominal typically fills the "subject" argument position of a "transitive" verb, though such terms are generally avoided in this work in favour of reference to the linking register of a predicate.

The extensive "indexing" function of Ergative and Dative in Warlpiri is further evidenced by the common occurrence of these two as

inflexions on nominals and infinitives already marked with a "semantic" Case or Complementiser (which is why these categories have the category feature [+C], in this account). See Granites, 1976:6, and 5.4.1.2, 7.3 below, for exemplification.

The double-marking phenomenon shows one difference between some of the homophonous Case and Complementiser pairs, in that the Cases rla 'Locative' and rla-jinta 'Comitative' may bear a further Ergative or Dative (i.e. are [+C]), but the homophonous 'Proximate Sequential' and 'Proximate Reflexive Accidental' Complementisers may not (i.e. are [-C]). Of course, the proximate nature of these two Complementisers means that the Dative, if added, would be inconsistent, and the Ergative would be redundant, whereas in their Case role this is not true.

Another function, peculiar to the Ergative, is the representation of an instrument participant role. In traditional Australianist terms, the Warlpiri Ergative exhibits a syncretism of the agent and instrumental case-relations -- e.g., as presented in Blake, 1977:44,60. In this work the two are not distinguished at the morphological level, but rather at the level of semantic interpretation. In the account of Control, 7.3.3(v), I propose that the "instrumental" interpretation is available for a nominal marked with Ergative (but not a Case or Complementiser bearing the Ergative) when it is indirectly associated with an argument position, i.e. as a special sort of Predication. (The major consideration in favour of this proposal is that the "instrumental" usage of the Ergative is not available in clauses with a verb which lacks an ERG-linked argument position; whereas in a number of languages, including ones genetically related to Warlpiri, this restriction does not hold -- see Blake, 1977:47.)

This section might be concluded with mention of another proposal for a feature system for the case suffixes of Warlpiri. Hale et al, 1977: 413 propose the features [subj] and [obj], as follows:

Ergative case is represented [+subj,-obj] (for mnemonic purposes, read this roughly as "capable of being the subject, but not the object"; the absolutive case is represented [+subj,+obj] ... and the dative case is represented [+obj,-subj]... These are the "pure grammatical" cases; all others, i.e. the "thematic cases" (e.g. locative, allative, elative, etc) are represented [-subj,-obj]. Using this feature system, we can define the Walbiri notions

"subject" and "object" by means of the following disjunctions:

"subject": [+subj, (-obj)]

"object" : [(-subj),+obj] .

In this work, the distinctions are made in other ways. The category distinction Argument versus Case separates Ergative and Dative from the other case inflexions, and I avoid setting up "Absolute" as a case inflexion  $\emptyset$ , either morphologically, or in "categorical signatures" (5.3). The features [subj] and [obj] would be most applicable to distinguishing Ergative from Dative, or, better, for providing features for the abstract case labels ERG, ABS, DAT used in linking registers. Furthermore, the rule of Construal (7.4) comes near to making use of notions equivalent to "subject" and "object" as defined by Hale et al (in the above quotation), as it matches subject and object person/number clitics in the Auxiliary with certain predicate argument positions.

### 2.3,5 SUMMARY

Apart from verbal inflexions (2.5) and enclitics (2.7), including the Auxiliary word, the above sections pretty well cover all Warlpiri affixes.

It might be noted how the arrangement of categories that has been set up in 2.3 produces a certain amount of necessary ordering among the suffixes. For instance, Argument suffixes must go on a [+C] stem, and these stems in turn may only be formed from [+N] stems. Hence, the possible orderings conform to a template like:

N-(CASE)	(ARG)
INF-COMP	

(though COMP is not allowed on INF when INF enters as a Preverb into a Preverb-Verb combination (2.6.2); and this template does not allow for COMP-(ARG) occurring on N).

The limitations of the template model for this type of suffixation is more apparent with the derivational suffixes, those which form N's from N's. The relative order of these is not fixed, but varies according to the meaning of the derived Nominal being expressed. Thus, we observe:

maliki-kirlangu-kari  
 dog -Possessive-another  
 'another one belonging to a/the dog'

maliki-kari-kirlangu  
 dog -another-Possessive  
 'belonging to another dog' ,

and so on, with many of such suffixes.

## 2.4 COMPOUNDING

Compounding of two words to form a third arises in several ways in Warlpiri. Certain Preverb-Verb combinations may be seen as compounds (see 2.6.5), and the various reduplicated stems and words have a lot in common with compounds (see Chapter 4). In this section the types of N - N compounds are briefly exemplified.

### 2.4.1 PRODUCTIVE PATTERNS

(a) The most productive type of N - N compound occurs with Nomic Agentive deverbal nominals (2.3.1.4). In a compound of the type:

$$[[ X ]_N [V\text{-Nomic}]_N ]_N$$

the X typically evaluates the ABS-linked argument position of the ERG-ABS linking register of V, and the entire compound Nominal corresponds to the ERG-linked argument position. Thus the examples:

marna-ngarnu  
 grass-eater 'grass eater, one who eats grass' .  
 yarla-karlangu  
 yam sp.-digger 'yam digger, one who digs yams'

See Hale, 1967:11 and 1969:8 for a few more examples.

This compound pattern has some instances with somewhat unpredictable meanings, which require a separate lexical entry. Examples of specialised Nomic Agentive compounds include:

kuyu-pungu  
 game-killer 'hunter, good hunter -- of man or dog,  
 or even of weapon'  
 kuyu-jutu-pungu  
 meat-"closer" 'caecum' (cf. jutu-pi-nyi 'to close off')  
 marnikiji-purrangu  
 conkerberry-burner 'small snake sp., "conkerberry snake"'

mulyu-pakarnu nose-hitter	'thick scrub'
ngarlkirdi-ngarnu wichetty grub-eater	'bandicoot sp., <u>pakuru</u> '
pirilyi-ngarnu charcoal-eater	'emu'
marntarla-rdilypirr-(y)ungu A. prunocarpa-piercer	'black borer beetle sp.'

This last example is one which shows a non-productive Preverb (rdilypirr) occurring in one of these compounds (Hale, 1966:738), and the following example shows the occurrence of a productive Preverb (muku):

ngatijirri-muku-ngarnu budgerigar-all -eater	'green snake sp.'
---	-------------------

(b) A minor productive type is the pattern:

$[[X]_N[jukurrpa]_N]_N$

which may form a personal name for an individual who has the totem X; note jukurrpa 'dreaming, totem'.

(c) A similar minor productive type is the pattern:

$[[X]_N[wati]_N]_N$  'a/the X one(s)',

based on wati 'man'. This pattern may be a recent innovation -- it is not found in Hale, 1959, 1966. Typical examples involve borrowings:

jija-wati	'hospital worker' (cf. <u>jija</u> 'sister, nurse')
kuurlu-wati	'school worder' (cf. <u>kuurlu</u> 'school')

Consider also this example from Junga Yimi 2.4 (1980), 15:

Yalijipiringi-wardingki-jarra ... ya-nu-rnu-pala nya-nja-ku  
 Alice Springs-resident-Dual go-Past-hither-33 see-Inf-Purposive  
 kurdu-kurdu-ku langa wijini-wati-ki.  
 children-Purp ear sore-ones-Purp

'The two Alice Springs people came to test the children's sore ears'

(Perhaps wati is now analysable as a derivational suffix, ie.  $]_{N-wati}]_N$ ).

## 2.4.2 NONPRODUCTIVE PATTERNS

Examples of frozen, idiosyncratic N - N compounds may be classified in traditional terms as follows;

(a) Exocentric, bahuvrihi compounds:

jaka-larra (buttocks-split) 'prickly bush sp., with  
double-pointed prickles'  
mulyu-kuna (nose-excrement) 'black-nosed python'  
kuna-maju (excrement-bad) 'emu'  
rdukurduku-tirirtiri (chest-red) 'red-breasted finch sp.'  
ngurra-rdangkarlpa (home,camp-short) 'middle-aged people'

## (b) Endocentric compounds:

lirra-pinpimpa (mouth-thin and flat) 'lip'  
langa-parraja (ear-coolamon) 'bat-ears, ears which stick out  
prominently at the sides of the head'  
mulyu-larra (nose-split) 'nosebleed'

The examples just given have their head, semantically speaking, occurring first. There is at least one example of a double-headed, dvandva, compound:

pirdangirli-kamparru (behind-ahead) 'one behind the other'

and possibly also in one of the ways of referring to the semi-patrimoieties by compounding the two adult male subsection terms involved, e.g.

Japanangka-Japangardi 'the semi-patrimoiety including the subsections  
of Japanangka and Japangardi' .

## (c) Other exocentric compounds:

There are three examples of the pattern:

[[ X ]<sub>N</sub>[pama]<sub>N</sub>]<sub>N</sub> 'grub which feeds on X (a plant sp.)'

based, apparently, on pama 'delicacy'. These compounds cannot be included among the endocentric type because the grub so named is not considered to be in the pama class of foods.<sup>3</sup> The examples are (Hale, 1966:716,725):

ngalyipi-pama (vine sp.-delicacy) 'striped speckled grub sp.'  
wayipi-pama (creeper sp.-delicacy) 'cut worm sp.'  
yarla-pama (yam sp.-delicacy) 'caterpillar sp.'

<sup>3</sup> As Hale (p.c.) suggests, these compounds may date back to a time when pama had a more general meaning, such as 'animal'; cf. \*pama 'person' elsewhere in Australia.

## 2.5 VERBAL INFLEXIONS

In this section the conjugational paradigms are briefly presented, for ease of reference. They are taken from Hale, 1969 and 1974:1,15.

CONJUGATION	NON-PAST	PAST	IMPERATIVE	IMMEDIATE-FUTURE	PRESENT
V1	(mi)	ja	ya (ˀka)	ju	nya
V3	nyi	ngu	ngka	ngku	nganya
V2	}rni,ni	}rnu	ka	ku	}rninya
V4			nja	lku	
V5	ni	nu	nta	nku	nanya

The citation form of a Verb is its Non-Past inflected form. This practice is adopted throughout this work, except in discussion of formal morphology (2.2). Note that the Non-Past inflexion is a sure sign of the conjugation-membership of a stem, with two provisos: (i) the longer form of the V1 Non-Past, mi is used as the citation form; (ii) the rni Non-Past is cited on V2 and V4 roots, to distinguish them from V5 roots, (though some speakers do prefer the ni form), and there is only one V4 root, viz. nga-rni 'eat; (in combinations) move' so all other rni roots are V2.

See the Appendix for a complete list of verb roots.

There are some details to be noted about each of the inflexional classes given above.

**NON-PAST:** The V1 roots show some preference for the longer mi form when a directional enclitic follows, but otherwise the alternation shows no grammatical conditioning except perhaps an emerging, ill-understood, aspectual distinction. The choice of rni over ni for V2 and V4 is an idiolectal matter, with no clear geographical basis.

**PAST:** These inflexions in u trigger vowel harmony in roots in i (3.5).

**IMPERATIVE:** Two common V1 roots, nyina-mi 'sit, be' and nguna-mi 'lie, recline' prefer the otherwise V2 Imperative ka; all other V1 roots take only ya. The Inceptive of V3 roots (see below) takes the irregular Imperative inflexion nka.

**IMMEDIATE-FUTURE:** This inflexion is common only in south-west dialects, and there undergoes progressive vowel assimilation, showing a i vowel on roots in i.



PRESENT: This inflexion is better termed "Presentational Present", and is also somewhat rare in modern Warlpiri, at least away from the south-west dialects.

Other verbal inflexions may be described as built on those already presented in the table. These are:

Nomic Agentive	= Past, except that V1 takes V3's Past ( <u>ngu</u> )
Irrealis	= Imperative - <u>rla</u>
Infinitive	= Root -<Non-Past> <u>-nja</u> , where c occurs iff the Root is V2,V4,V5
Inceptive (V5 stem)	= { Infinitive (on V3 root; Imperative is <u>nka</u> ) Infinitive - <u>nji</u> (on V3 root) (rapid speech) Infinitive, with final <u>i</u> instead of <u>a</u> (not on V3)
Progressive	= Inceptive - <u>na</u>

The Nomic Agentive is discussed in 2.3.1.4 and 2.4. Sample paradigms of the Infinitive and Inceptive are given in the discussion of stress in 3.6.4.2.

The Progressive, like the Inceptive, is a V5 stem (thereby betraying their likely historical connexion with ya-ni 'to go', also V5). The Progressive expresses much the same idea as the Infinitive Preverb construction with ya-ni (2.6.2), as illustrated in the following textual example:

Ngapa-ngku-ju-ju karrka-nja-ya-ni-nja-kurra-juku nyampirlpa-rni  
 water-Erg-Top-me proceed-Inf-go-Inf-Obj Comp-still splash-hither  
 paka-rnu. Karrka-nji-na-nu-juku-lpa-rna.  
 hit-Past proceed-Incep-Prog-Past-still-Imperf-I  
 'The water splashed me as I was still going along. I was still  
 going along.' (Hale,1966:476)

An example of the two constructions in the one complex verb occurs in the sentence in Note 5, 2.6.2.

The interaction of the Non-Past, Past, and Irrealis forms with the (non-zero) Auxiliary bases ka 'Present', lpa 'Imperfect', kapu 'Future' and kala 'Usitative' is presented in 7.6.

## 2.6 PREVERBS

There are a large number of "adverbial" elements in Warlpiri, and these occur only in concert with an inflected verb. These "pure" Preverbs are discussed in 2.6.4 below. In addition, words from other categories have the possibility of occurring as Preverbs.

When a word from another category is used as a Preverb, I propose to retain its basic category-labelled brackets, and provide the word with an additional, outer, pair of brackets labelled with the Preverb category. Thus, when the Nominal yiri '1. point; 2. sharp -- of point' is used with the Causative root ma-ni, the complex Verb is formed:

[[[yiri]<sub>N</sub>]<sub>PVB</sub>[ma-ni]<sub>V</sub>]<sub>V</sub> 'to sharpen' .

This, then, is an instance of "zero-derivation"<sup>4</sup>, according to my proposal.

### 2.6.1 N, CASE AS PREVERBS

There are two verb stems which may combine with virtually any Nominal in Warlpiri, but which do not combine with other sorts of Preverbs. These two stems are usually described as "verb formatives" (Hale, 1974:15) or derivational affixes which "verbalise" a Nominal, setting them apart from other verb stems (which may combine with non-Nominal Preverbs). While that analysis may prove to be the only tenable one, I want to propose that the complex verbs formed by these two stems are in fact instances, albeit with some special properties, of the general Preverb-Verb pattern. Thus I recognise the two verb stems:

[[ X ]<sub>N</sub>]<sub>PVB</sub> [jarri-mi]<sub>V</sub> 'Inchoative; to become X'

[[ X ]<sub>N</sub>]<sub>PVB</sub> [ma-ni]<sub>V</sub> 'Causative; to cause to become X'

The content "X" of the Preverb is always attributed of the ABS-linked argument of the complex verb, as in this typical example:

Wati-ngki ka kurlarda yiri-ma-ni.  
 man-Erg Pres spear sharp-Caus-NPast  
 'The man is sharpening the spear' .

<sup>4</sup> A similar treatment of zero-derivation in English is given by Lieber, 1980, in that a "zero-morpheme" is not recognised. However, Lieber does not recognise a bracketing such as [[paint]<sub>N</sub>]<sub>V</sub> but rather relates the independently listed [paint]<sub>N</sub> and [paint]<sub>V</sub> through "morphological conversion".

There is an independent verb stem synchronically distinguished from the Causative, viz. ma-ni 'to take, get; affect'. Though some complex verbs involving ma-ni may seem susceptible of two analyses (i.e. based on the Causative, or based on independent ma-ni), it is generally fairly clear which stem is involved. If the Preverb is not also a Nominal, then the stem cannot be the Causative, for instance,

The Causative stem has been recorded with Preverbs apparently derived from Case, as in:

jinta-kurra-ma-ni		
one-Allative-		'to assemble, heap together'
walya-kurra-ma-ni		
ground-Allative		'to put to the ground; to land (aircraft)'
yilyanja-ngurlu-ma-ni		
sending-Elative-		'to flush out (game)'

though the lack of productivity means that these complex stems require their own lexical entry. Further, there is one complex stem apparently derived from a Complementiser (reduplicated):

yinka-ku-yinka-ku-ma-ni		
laughter-Purp-		'to make someone laugh'

and, for one speaker at least, this stem:

yula-nja-ku-ma-ni		
cry-Inf-Purp-		'to make someone cry' .

Preverbs derived from N may occur with other verb stems as well. One example is:

marlpa-nyina-mi		
company-sit		'to sit in company, have each other as company'

(cf. [marlpa]<sub>N</sub> 'company, companionship, comfort, protection'). Typically, the N is predicated of the ABS-linked argument of the complex verb, not only as in the one-argument verb just given, but also as in the two-argument:

larra-paji-rni		
split-cut-		'to split it by cutting'

(cf. [larra]<sub>N</sub> 'crack, split'). These constructions are rather like noun-incorporation in other languages.

An Infinitive may combine with any of the three verbs of motion in the following pattern;

$$[[X]_{\text{INF}}]_{\text{PVB}} \left[ \begin{array}{l} \text{ya-ni} \\ \text{parnka-mi} \\ \text{pard-mi} \end{array} \right]_{\text{V}} \text{ 'to } \left[ \begin{array}{l} \text{go} \\ \text{run} \\ \text{arise} \end{array} \right] \text{ X-ing'}$$

The functional structure of the complex verb incorporates the linked functional structure of the Infinitive, so that the participant role of "goer" is, in these complex verbs, filled by an Ergative if the Infinitive normally has an argument position linked to ERG. An example<sup>5</sup> of such a construction is (from Hale, 1974:15):

Kuyu ka-rlipa paka-rni-nja ya-ni.  
 meat Pres-122 kill- Inf go-NPast  
 'We (plural inclusive) are going along killing game' .

The Preverb may itself be an Infinitive of a Preverb-Verb combination, as in this textual example (Hale, 1966:458):

... kala ngari ka-rna-lu nya-nyi kuja-ka  
 but just Pres-111 see-NPast Rel-Pres  
 maarrpa-rni-ma-ni-nja-ya-ni. (cf. maarr-ma-ni 'to flash')  
 flash-hither-V- Inf -go-NPast (see also 2.6.5, on maarrpa)  
 'But we just see it [lightning] coming flashing' .

There appears to be at least one lexicalised verb of this type:

kiji-rni-nja-parnka-mi  
 throw- Inf -run 'to toss on top of one another  
 (so as to make a heap)' (see 4.4(36))

The Infinitive of the four basic verbs of stance may be used as Preverbs of the verb stem yirra-rni 'to put, place' to express the stance of the object being placed. Thus karri-nja-yirra-rni 'to put in a standing position', cf. karri-mi 'to stand'. Note also parntarri-nja-wanti-mi 'bend down (to drink)', cf. wanti-mi 'fall, drop'.

<sup>5</sup> A more complex example occurs in a text (Hale, 1966:1280):

Yaparranji nyanungu-ku-ju ka-lu-rla pına-yi-nja-yâ-ni-nji-na-ni.  
 youth him -Dat-Top Pres-333-Dat show-Inf-go- Incep-Prog-NPast  
 'They're going along showing [it] to the youth'

which also shows the Infinitive itself containing a Preverb.

An Infinitive Preverb, in combination with ya-ni at least, may host a directional enclitic (2.7.2) as shown by the following example:

...yi-lpa-rlipa jurlarda-lku paka-rni-nja-rni-ya-nta-rla  
Causal-Imperf-122 sugarbag-then strike-Inf-hither-go-Irrealis

kujarni-rli-ji.

on the other side of-Erg-Top

'...so we (Incl. Plural) would come chopping sugarbag [native beehive]  
on the other side.'  
(Hale,1959:642)

When hosting a directional enclitic, the Infinitive is apparently not sufficiently separated from the Verb ya-ni to require the Auxiliary to occur immediately after the directional. Thus, in the following example, the Auxiliary pala occurs after the entire verb complex, even though the Infinitive hosts the directional mpa:

Ngulajuku, ya-ni-nja-mpa-ya-nta-pala kuja-purda-yijala.

alright go-Inf-across-go-Imp-22 thus-wards-also

'Alright, you two go across this way too!' (Hale,1959:672[165])

In fact, I have encountered no examples of an Auxiliary intervening between an Infinitive and the following Verb in the construction under discussion. Thus the splitting rule of 2.6.5 is restricted in its application to this construction. Further examples are in 4.4.2(11)(59) and 4.4(37).

The meaning of the construction with ya-ni is apparently very similar to that of the Progressive -- see the example in 2.5.

Note that a directional enclitic may also occur suffixed to an Infinitive, preceding a Complementiser suffix. This possibility (not shared with an other formative), together with the fact that the Auxiliary does not intervene between an Infinitive and a following Verb such as ya-ni, suggests that the analysis proposed in this section may be inferior to one which does not allow Infinitives as Preverbs, but rather derives the constructions by direct compounding of INF and V.

## 2.6,3 VERB ROOTS AS PREVERBS

A few complex verbs in Warlpiri use a Preverb that appears to be identical (in form and meaning) with a separately occurring verb root. The examples I know of are:

parnti-pura-mi 'to follow the smell of' (Hale, 1966:758)

parnti-nya-nyi 'to smell, perceive odour'

(cf. parnti-mi 'to smell, give off odour', pura-mi 'to follow', nya-nyi 'to see, look at');

parntarri-yirra-rni 'to put in a heap'

(cf. parntarri-mi 'to crouch, be humped'; yirra-rni 'to put, place')

palu-pi-nyi '1. to extinguish (fire); 2. to kill'

(cf. pali-mi 'to die', pi-nyi 'to hit, act on') .

It may be significant that these three verb roots all belong to the conjugation (V1) which is the only one to allow the root as a well-formed independent word (the "zero" alternant of the NonPast mi form). Two other V1 verbs have been recorded with their roots used in a derived context: (i) kulpa-mi 'to return' is apparently related (at least, historically) to the adverbial Preverb kulpari 'on the way back'; (ii) yuka-mi '1. to enter; 2. to set (of heavenly body)' was recently called into service when the Nominal munga 'night' was tabooed (Mary Laughren, p.c.). Not only was yuka used in the sense of munga (no doubt from the association of 'sunset' with 'night'), but even the related word mungalyurru 'morning, around sunrise' was replaced by yukalyurru.

With some speakers, there may be more possibilities. For instance, there is a textual example of:

pangi-pangi-ma-ni 'to dig by hand around cooking ashes to heap up ashes for cooking'

(cf. pangi-rni 'to dig'). Note also that when verbs are borrowed into Warlpiri, at least from English, they are taken as Preverbs of ma-ni or -jarri-mi (cf. 2.6.1) depending on the transitivity.

There are a large number of Preverbs which resist any synchronic derivation from another part of speech. According to their distribution, they fall into two classes; those that combine freely with any Verb, and those that are found only with a few, or perhaps only one, verb stem.

## 2.6.4.1 PRODUCTIVE PREVERBS

The productive Preverbs fall into the following semantically-based groups, which also have certain morphological correlates:

## (i) adverbial Preverbs

## (a) types of motion, or position

jaala	'back and forth'
jawirri	'leaving behind, V and leave'
japara	'eating while going along'
jarrwara	'wrong direction, astray'
jiwirlki <sup>2</sup>	'with appendage bouncing'
juruju	'rolling, sliding'
laja	'carrying'
kulpari	'returning, on the way back'
jangkardu <sup>6</sup>	'against, in opposition, with aggression'
warru	'around'
julyurl(pa)	'into water, fire; in water, fire'
yaarl(pa) <sup>6</sup>	'over the top of'
rarra	'dragging'
pina	'in return, back'
wararrku	'slithering, meandering'
jayirra	'snatching'
jaantaku	'protruding'
wajili	'running'
juka(juka)	'jutting upwards'

## (b) other types of action

rdalji	'motionless'
milki	'demonstrating'
kanginy(pa)	'failing to perceive'

<sup>6</sup> These Preverbs can take a Dative Argument, cross-referenced in the Auxiliary. An example is: Ngarrka ka-ju ngaju-ku jangkardu-ya-ni-rni, 'The man is "coming at me".'

juul(pa)	'up to a point, halfway'
jaalypa	'whispering'
jamparl	'chomping'
wapal(pa)	'searching'
pirriki	'in pity'
wapirdi	'on arrival, on approach of'
(c) quantifiers	
jarnku	} 'Distributive; each'
palju	
kutu	'to do anything, anywhere, anyhow'
puta	'Partitive; some, partly'
muku	'all, completely'
	(see Granites, 1976:5, and on <u>yarda</u> pp.9,11)
warrarda	'always, consistently'
yarda	'Iterative; more, again'

These Preverbs appear to merge into adverbial-type Nominals, but may be distinguished morphologically in that (i) these Preverbs may host directional enclitics (2.7.2), while Nominals can not, and (ii) Nominals may take Case inflexions, while Preverbs can not. Nevertheless, this account does not rule out words which are doubly-classified, both as N and PVB. An example of a doubly-classified word may be wurulypa 'seclusion, concealment', which apparently has the possibilities both of hosting a directional enclitic, and of taking certain case (perhaps Ergative) inflections. The classification of Warlpiri Preverbs presented here must be regarded as quite preliminary.

(ii) "Dative adjunct" Preverbs

jurnta	'removal, adversity, away from, to the disadvantage of' (see Granites, 1976:11)
jirrnganja	} 'Comitative, with dependent' (Granites, 1976:10)
yirrkirnpa	
kaji (Y)	} 'Benefactive, because of'
ngayi (W)	
marlaja	'Causative, made possible by'
	(cf. <u>marlangka</u> , a restricted variant)



The "Dative adjunct" Preverbs can not host a directional, or any other enclitic. These Preverbs are so named because they introduce an extra argument to the functional structure of the verb they combine with, and this argument position is always linked to DAT in the linking register of the complex verb (6.1). Furthermore, the Dative argument position introduced by these Preverbs must be construed, or "registered", in the Auxiliary pronominal clitic sequence. Since the Auxiliary has a maximum of two positions for registration of Dative Arguments (see 2.7.1), these "Dative adjunct" Preverbs cannot occur with Verbs to which the diathetical rule demoting ABS to DAT has applied (see the discussion in Chapter 6); nor can more than one "Dative adjunct" Preverb occur in the one complex verb.<sup>7</sup>

Subject to the restriction just mentioned, it is quite possible to have two Preverbs occurring with one verb stem. A typical example would have an "outer" productive Preverb, and an "inner" non-productive one or perhaps an "inner" productive one. For instance:

Pirlangkiti-ji jurnta-kuju-rnu yàrda.

blanket-me away -throw-Past again

'He threw off my blanket again' (Hale, 1959:498)

where the "quantifier" Preverb yàrda has scope over the combination of kiji-rni 'throw' with the "Dative" Preverb jurnta, which introduces the argument position here construed with the pronominal clitic ju-ji '1st person sing. object'. The occurrence of the "outer" Preverb after, instead of preceding, the Verb is a topic addressed in 2.6.5.

#### 2.6.4.2 NON-PRODUCTIVE PREVERBS

There are a large number of complex verb stems in Warlpiri which are analysable according to the Preverb-Verb pattern (and, in fact, need to be to maintain otherwise well-established phonotactic and metrical generalisations) but which thereby introduce Preverbs with very restricted powers of combination.

---

<sup>7</sup> The two "adverbial Preverbs" listed earlier (cf. footnote 6) may in fact be "Dative adjunct" Preverbs, which are exceptional in that they may introduce a Dative Argument and host directional enclitics.

There are a small number of verb roots which stand out as taking a large number of these idiosyncratic non-productive Preverbs, to form complex verb stems often with meanings having little to do with the sense of the root verb. These roots are:

karri-mi	'stand'
nyina-mi	'sit, be'
pardi-mi	'arise, emerge, start off'
wanti-mi	'fall, drop'
jirri-rni	'affect (?)' (does not occur uncombined)
kiji-rni	'throw, cause to fall'
ka-nyi	'carry'
pi-nyi	'hit, act on'
yi-nyi	'give'
nga-rni	'move (?)' (does not occur uncombined) (distinct from <u>nga-rni</u> 'eat')
ma-ni	'make sound' (does not occur uncombined) (distinct from <u>ma-ni</u> 'get, take', and from the Causative <u>ma-ni</u> , 2.6.1)
ya-ni	'go'

An example of an idiosyncratic combination is:

pata-karri-mi 'fall'

where pata is not known, at least in any clearly connected sense, outside this combination, and the sense of karri-mi 'stand' is pretty much absent, except perhaps in the element of "vertical dimension". The meaning of the complex stem is in some instances so changed that the case-frame, or "linking register" of the root verb does not survive. This is true, for instance, of:

wurru-ka-nyi	} 'to stalk, sneak up on'
yura-ka-nyi	

which takes an ABS (sometimes ERG) subject, and a DAT object, whereas the root ka-nyi has the case-frame ERG - ABS, (Note that wurru and yura occur nowhere else in Warlpiri.)

Some non-productive Preverbs do occur with more than one verb root.

An example is turluny, occurring in;

turluny-(y)irra-rni 'to bend it double -- as tongue'  
 turluny-panti-rni 'to bend it double and pierce it'

but in no other known combinations, but nevertheless with an isolable meaning ('bent double').

The "deverbal" Preverbs listed in 2.6.3 may properly be included among the non-productive Preverbs.

As mentioned in 2.6.4.1, a productive Preverb can combine with a Preverb-Verb combination. An example with a non-productive "inner" Preverb is the following: (cf. rdilypirra '1. small hole; 2. flesh wound'):

Kiwinyi-rli-ji pu-ngu, rdilypirr-karri ka-rna-rla marlaja.  
 mosquito-Erg-me bite-Past, wounded-(NPast) Pres-I-Dat Causative  
 'The mosquito bit me, I'm wounded by it' (Hale, 1959:812) .

#### 2.6.5 PERMUTATION OF PREVERB AND VERB

In the account of Warlpiri Preverbs in the preceding subsections, a basic order of the Preverb and the verb stem with which it combines has been assumed, namely that in which the Preverb immediately precedes the verb stem. And indeed this is the predominant order observed, and for many combinations is the only possible order. But in a number of complex Verbs, the Preverb may occur elsewhere. This has already been noted in the two examples given of two Preverbs occurring with one verb root -- the "outer" (productive) Preverb followed the Preverb-Verb combination within its scope, the preferred situation when there are two Preverbs.

The following generalisation goes a long way to capturing the observed variation in orderings:

If X is (i) a productive Preverb (2.6.4.1), or (ii) a Preverb "zero-derived" from N (2.6.1), then it may combine with an inflected Verb in the following ways:

- (1) [ [ X ]<sub>pyB</sub> Verb ]<sub>[+V]</sub>
- (2) [ X ]<sub>PVB</sub> Verb
- (3) Verb [ X ]<sub>pyB</sub> , provided the Verb may also occur alone.

(where "inflected Verb" includes Infinitive, hence the [+V] category feature in (1); [+V] should strictly stand in these patterns instead of "Verb", but is avoided for clarity).

The distinction between (1) and (2) in this rule shows up with respect to the placement of clitics, particularly the directional enclitics, and the Auxiliary clitic. The latter occurs in "second position" in a sentence (or else initially -- see 5.6), basically after the first immediate constituent of the sentence. To preserve the generality of the statement of Auxiliary-placement, we need to recognise the two possible constituent patterns (1) and (2). An example illustrating the variability of orderings is as follows:

- (1) Wuruly(pa)-ya-ni-rli.  
 seclusion-go-NPast-12      'Let's go and hide'
- (2) Wurulypa-rli ya-ni.  
 seclusion-12 go-NPast
- (3) Ya-ni-rli wurulypa.<sup>8</sup>  
 go-NPast-12 seclusion

In these sentences, the Auxiliary is represented by the pronominal clitic rli 'we Dual Inclusive subject'.

Note that options (2) and (3) require the "augmented" alternant of the Preverb. This follows from the above generalisation provided that (i) the alternant wuruly is not regarded as a "productive" Preverb, but rather may combine with verbs that it is lexically listed as combinable with, and (ii) the alternant wurulypa is regarded as a "productive" Preverb, or as being zero-derived from N. In this example, the second proviso is indeed met, although the first is rather suspect. A plausible "morpholexical rule" in Warlpiri is the following:

pa-Augmentation: [ XC ]<sub>PVB</sub> ==> [ XCpa ]<sub>N</sub>, where X = (C.V)<sub>1</sub>.

and the N produced by this rule may in turn act as a PVB. Thus, for (2) above I propose the structure:

[[wurulypa]<sub>N</sub>]<sub>PVB</sub> rli [ya-ni]<sub>V</sub>

which may prove to be correct. However, it seems just as likely that the

---

<sup>8</sup> The fourth possibility, Yani-wurulypa-rli, has been observed in a text, but it is apparently far less common than the above three possibilities.

correct structure for (2) has no internal N, and is simply:

[wurulypa]<sub>PVB</sub> rli [ya-ni]<sub>V</sub>

for there are a number of Preverbs in pa which rarely, if ever, are used as Nominals (e.g. with a case suffix). For instance, the non-productive Preverb paarr(pa), as in paarr-pardi-mi 'take off in flight' may be able to be used as a Nominal, ?[paarrpa]<sub>N</sub>, but there is no evidence of this yet. However, it has nevertheless been observed participating in pattern (2):

Walya-wana-rlangu ka-lu wapa, paarrpa-rra-yijala ka-lu pardi  
ground-Perl-e.g. Pres-333 walk flight-forth-also Pres-333 arise  
ngapilkiri-piya -- yupurru-ju.

crested pigeon-like pigeon-Topic (Hale, 1966:574)

'They walk along the ground, they take off in flight also, like a  
crested pigeon -- the yupurru pigeon'

In this example, a directional enclitic (rra), another enclitic (yijala), and an Auxiliary (with base ka) all intrude between the non-productive Preverb and the Verb with which it combines. Perhaps, then, the account here proposed will need to be modified, if it is shown that words such as paarrpa are not derived from N's.

The extra restriction which applies to pattern (3) above, that the stem Verb be one that is capable of occurring without any Preverb, means that the pattern (3) is available for only some of the combinations which occur in patterns (1) and (2). A clear example of a verb stem obeying this restriction is the Inchoative stem -jarri-mi (2.6.1). For instance, the Nominal kulu 'anger, fight' combines with the Inchoative stem to form the complex verb kulu-jarri-mi 'become angry'. Hence it is possible to say:

[[[Kulu]<sub>N</sub>]<sub>PVB</sub> [jarri-ja]<sub>V</sub>]<sub>V</sub> lu-nganpa.

anger -Inchoative-Past-333-111 'They got angry at us (ex. pl.)'

according to pattern (1). This expression has also been observed in pattern (2) (Hale, 1979:64):

[[Kulu]<sub>N</sub>]<sub>PVB</sub> lu-nganpa [jarri-ja]<sub>V</sub>. (same meaning)

but is undoubtedly ill-formed in pattern (3):

\* [Jarri-ja]<sub>V</sub> lu-nganpa kulu.

The question also arises as to how the rule producing the various permutations of Preverb and Verb is to be integrated with the account of Warlpiri syntax in Chapter 5. I assume that the various patterns are produced by productive rules of word-formation, part of the word-formation component of the "extended" lexicon. Thus a "split" Preverb-Verb combination (patterns (2) and (3)) is generated as two separate words, whereas the combination (1) is generated as a single word. This approach will give the observed Auxiliary and enclitic placement facts, but will also give a large degree of "overgeneration". This will occur because there is nothing to stop a "split" Preverb and Verb from occurring separately in the generated string, with an unlimited number of other words intervening, or from generating a Preverb without any Verb in the string. Furthermore, the extra restriction placed on the occurrence of pattern (3) would not be storable, since the distinction between patterns (2) and (3) would be lost.

Actually, an "overgeneration" account such as this may prove workable. There may be justification for independent constraints on the interpretability of Preverbs, with the effect of the patterns (2) and (3) -- this is in the spirit of the "autonomous systems" view of grammar, as propounded for instance in Hale, Jeanne & Platero, 1977, and the references cited there. For instance, it would make sense to require that a Preverb be related to a Verb in the same sentence as a pre-requisite for its interpretation, and it would be possible to further require that the Preverb be "close" (perhaps, adjacent, except for clitics) to the Verb with which it receives its interpretation. Indeed, sentences have been observed with productive Preverbs separated by other words from their related Verb (Mary Laughren, p.c.), as in this example:

Japiya muku ka-lu panu-ngku nga-rni.  
 big all Pres-333 many-Erg eat-NPast  
 'Many of them are eating a whole lot' .

Another observation about the Preverb-Verb combination, which is clearly relevant to an understanding of Warlpiri word-formation and syntax, but whose significance is beyond the scope of this account, has been made by Hale(p.c.) in connexion with his proposed "Punctuation" component of the grammar (Hale, 1979:48). The observation is that in all three patterns

(1) - (3) of a combined Preverb and Verb, the stress of the second part is subordinated to that of the first part. Consider this example (based on Hale, 1966:543):

(1) múku-ngàrnu-jana (all-eat:Past-them)

(2) múku-jana ngàrnu

(3) ngàrnu-jana mùku

where muku is a productive Preverb, interpreted with the verb nga-rni and combined with the object pronominal clitic jana. It appears that a metrical tree such as built on all compounds is built on the Preverb - Verb combination even though it is "split", as in (2) and (3). The import of this cannot be fully appreciated until a systematic study of Warlpiri intonation and phrasing has been made, but it may turn out, as Hale has suggested, that a local movement rule (akin to infixation) is justifiable, which would move an adjacent Auxiliary into the major metrical break of the Preverb - Verb combination, without destroying the compound-level metrical tree encompassing both words. (Note however, that an Auxiliary has not been observed to break up a N-N compound in a parallel fashion, though there may be independent reasons for this.)

## 2.7 ENCLITICS

Warlpiri enclitics fall into four subclasses, according to their combinatory possibilities:

(i) "pure" enclitics

(ii) "derivational" enclitics

(iii) Auxiliary enclitics (2.7.1)

(iv) directional enclitics (2.7.2)

and I consider them in turn. There are no proclitics in Warlpiri. There are, however, words which might be termed "sentence clitics", in that they prefer to occur initially or in "2nd position" (depending on their length) in a sentence. These are the Modal Particles, and the Auxiliary, for the placement of which see 5.6. The Auxiliary is formed of elements some of which are like enclitics, and so the structure of the Auxiliary is discussed in this section as well.

Warlpiri enclitics are so-called because they exhibit the following combination of affix and non-affix properties:

## (i) affix properties:

- (a) the enclitics must attach to a word -- they cannot stand alone, or begin a word;
- (b) enclitics are part of the phonological word to which they are attached, both for vowel assimilation (3.4-3.5) and stress (3.6).

## (ii) non-affix properties:

- (a) in general any word may host an enclitic -- they are "universal affixes" (a term used by Dixon, 1972:266-68) in that they may occur attached to any type of word (except, in Warlpiri, the Auxiliary);
- (b) an enclitic may not precede a non-enclitic affix (with the exception in Warlpiri of the "derivational enclitics");
- (c) the semantic scope of an enclitic may extend beyond the word to which it is attached, often to the whole clause (as happens also with some of the Modal Particles).

For a typological survey of clitics, see Zwicky, 1977 (who refers to Warlpiri pronominal clitics, pp. 19,29). The study of the semantics of Warlpiri enclitics is largely unexplored, but has rich possibilities, suggested, for instance, by the extensive treatment they receive in the grammar of another Australian language (Donaldson, 1980 -- and see the further commentary of Klavans, 1979).

The "pure" enclitics of Warlpiri are:

-ja	'Assertive'
-jala	'after all, obviously, as you know, actually'
-ju (Y)	'1. (on nominals) Topic, Definite, the; 2. (phonological extension)'
-ji (W,H)	
-juku	'still, yet, now as then'
-kirli	'precisely'
-kula	'Contrastive, Concessive, rather'
-lku	'now, then, and then'
-nya	'Emphatic, Focus, Interrogative'
-waja	'I say, obviously'
-wiyi	'first, before'
-wu(rru)	'Emphatic' (Jagst, 1975:44 has <u>wu</u> )
-yijala	'also'



The "derivational enclitics" are listed in 2.3.1.1.

Certain combinations of these enclitics occur, including:

-lku-yijala	'then also'
-juku-jala	'still, despite this'
-kula-jala	'or even'
-rlangu-kula	'even, also, in addition'
-mipa(-lku)-juku	'only'
-rlangu-puka	'or even, or else'

Note that a "derivational enclitic" does not follow a "pure enclitic".

I propose to incorporate these enclitics into the general framework of word-formation by assigning them the following context as part of their lexical entry:

] ---- ] .

In the theory adopted in this work, this will be the category "label" of an enclitic, i.e. category brackets without category labels on them. Thus, when an enclitic combines with a word, the combined structure is as in these examples, using the enclitic lku:

[[pardi-ja] <sub>V</sub> lku]	'then he set off'
[[wati] <sub>N</sub> lki]	'then the man...'

Note the conventions I am assuming with respect to the interpretation of these unlabeled category brackets:

- (i) on the left of a morpheme, an unlabelled bracket ] is interpreted as allowing any category label to fall under it. For example, ]<sub>V</sub> and ]<sub>N</sub>, for instance, fall under the context of ]lku].
- (ii) on the right of a morpheme, an unlabelled bracket ] is interpreted as being bare of any category specification, so that another morpheme which as part of its context requires a certain category label (or, more generally, the presence of a certain category feature) may not follow. For example, an enclitic may follow a derivational suffix, but not vice versa: [[[purlka]<sub>N</sub>pardu]<sub>N</sub>lku] 'dear old man-then', but not\*[[[purlka]<sub>N</sub>lku]pardu], because the suffix is ]<sub>N</sub>pardu]<sub>N</sub>.

These conventions will lead to just the observed orderings of enclitics and suffixes, and fit with the affix and non-affix properties of enclitics listed earlier in this section.

Furthermore, the lack of category labels on enclitics fits naturally with their being ignored in the formation of "categorical signatures" (5.3). -- only brackets with category labels "project" to form these syntactic labels.

This approach to the incorporation of enclitics in word-formation suffers to some extent from "over-generation". In this approach, there is no limit to the number of enclitics which may attach to the one word, nor any restrictions on their relative order. Now combinations of more than one enclitic do occur (and some are listed above), but there seem to be additional restrictions on their relative order. For instance, the enclitic ju is not followed by other enclitics (leaving aside the Auxiliary), and the "derivational enclitics" (those doubly-classified as ]<sub>N</sub>---] <sub>N</sub> and ]---]) prefer to attach directly to a category-labelled word and precede other enclitics. Some enclitics are more commonly found on one part of speech than other -- in fact, in the case of ju, it may be possible to include a category specification on the left-hand context bracket, say [-V], for it is found on Verbs only when they are used in a quotation, as in introducing a definition of a Verb. (Cf. Rotenberg, 1978:193-95, who shows that, in English at least, "a quotation is a noun".) The strategy involved in my proposal is to look for independent constraints on the occurrence of enclitics, which work on the possible combinations given by the word-formation component, as it is set forth in this chapter.

A strong point of this approach to enclitics is that it places enclitics formally between affixes and non-affixes with respect to their properties, without setting up a separate "level" of cliticisation. Still the distinction between "grammatical word" (here, a bearer of a "categorical signature", i.e. an outermost pair of labelled brackets) and "phonological word" (here, an outermost pair of brackets, labelled or not) is easily made. (Cf. the discussion in Rotenberg, 1978:157, etc.).

### 2.7.1 THE AUXILIARY WORD

The Auxiliary is of central importance in Warlpiri grammar, and has a number of properties that set it off from other parts of speech:

- (1) the Auxiliary may occur only in initial or "second" position in the sentence, a property shared only with a few Modal Particles (5.6);

- (ii) depending on its composition, the Auxiliary may be either an independent phonological word (and thus capable of beginning a sentence) or a clitic;
- (iii) the Auxiliary is the only part of speech which never hosts an enclitic<sup>9</sup> (i.e. a lexical item with context ]---], not to be confused with the pronominal elements within the Auxiliary);
- (iv) even when it is phonologically an independent word, an Auxiliary is never a complete utterance -- the Auxiliary elements require a predicate word in the same sentence for their interpretation (as discussed in 7.4, 7.6);
- (v) the internal structure of the Auxiliary is like that of no other poly-morphemic word in Warlpiri -- it is "flat", not hierarchical in the way that all other complex words are (an observation made by both Laughren and Hale, and see the comments in Hale, 1979:66n14).

Following Hale's (ibid.) suggestion of the parallel with the "flat" structure of Navajo verb prefixes, I propose the following "morpheme order chart", or "template", for the Warlpiri Auxiliary, which helps throw light on properties (ii), (iii) and (v) above.

		subject	object		
kapu - kapi - ngarra		rna	ju	'1'	
kalaka		n(pa)	ngku	'2'	
		rli	ngali(ngki)	'12'	
kula	ka	rlijarra	jarrangu	'11'	rli
kaji	lpa	n(pa)-pala	ngku-pala	'22'	
kuja - ngula	kala	pala	palangu	'33'	
yungu - yinga		rli pa	ngalpa	'122'	
		rna-lu	nganpa	'111'	
		nku-lu	nyarra	'222'	
		lu	'jana	'333'	

The numerals refer to the pronominal categories of person and number, following Hale, 1973a:315 and 1974:5 -- for instance, '11' means '1st

<sup>9</sup> The form /walj.ka.ka.ṅal.ku/ 'I am feeling cool now' is given by Jagst, 1975:41, in a discussion of syllable structure. Rendered in the practical orthography, the form is \*walyka-ka-rna-lku (cold-Pres-I-now) and shows the enclitic lku follow the Auxiliary ka-rna, but I am assured by Hale and Laughren that this is definitely ill-formed, and would furthermore require a Verb, for ka to be interpreted.

person Exclusive Dual, I and he/she/it', The meanings of the other elements are as follows;

kapu, kapi, ngarra(H)	'Future'
kalaka	'Admonitive'
kula	'Negative'
kaji	'if, when'
kuja (Y,W), ngula(H)	'Relative'
yungu, yinga	'Causal' (==> <u>yi</u> non-finally, Opt.)
ka	'Present'
lpa	'Imperfect'
kala	'Usitative'

with the following two combinations having a special sense:

kaji-ka	'Potential'
kuja-ka	'Present Presentational'.

The elements just listed are sometimes referred to as "Auxiliary bases", particularly ka, lpa, and kapu. Kula, kaji, kuja and yungu have been called "Auxiliary complementisers" in Hale, 1976c, because of certain functional similarities with the Complementisers on Infinitives (2.3.3).

The pronominal clitic sequence is subject to certain "rules of form", which permute adjacent elements, delete the '2nd person' elements n(pa) and nku in imperatives, and neutralise certain combinations of two 'Dual' clitics. These processes are detailed in Hale, 1973a and 1974:6, and are best stated in terms of the person and number features proposed there (see 5.4.1.1 for number features), except for the permutation rule, which may be stated as (prior to application of vowel harmony):

<u>lu</u>	<u>ju</u>			
<u>pala</u>	<u>ngku</u>			
1	2	==>	2	1 , Obligatory .

There are two further pronominal clitics that do not appear in the above Auxiliary template: (1) nyanu 'Reflexive', fits in the "object" slot, with the proviso that rna-ju occurs instead of \*rna-nyanu, and while \*npa-ngku does not occur, ngku may occur instead of nyanu in singular imperatives; (b) the further Dative clitic jinta may occur after rla, and only occurs with rla immediately preceding, (Costandi, 1975:106, addresses this data.)

In general, there is little interdependency among the elements in the

Auxiliary. Each "slot" in the template is optionally filled<sup>10</sup>, so that the Auxiliary may have as many as 12 syllables, or as few as none (in a sense!) or one. What interdependency there is, is not simply expressible in terms of labelled brackets and context frames, or some equivalent encoding of hierarchical structure. Such considerations are behind the property (v) of "flatness".

As to the inability of the Auxiliary to host enclitics, property (iii) above, I propose that the Auxiliary word, unlike other Warlpiri words, does not have any category brackets.<sup>11</sup> As a notational device, at least, this has the desired effect -- all suffixes and enclitics have a bracket ] (perhaps bearing a label or category feature specification) in their left context, and the Auxiliary does not provide one to satisfy this context requirement. Notationally, I show its boundaries simply with hyphens. But, in the spirit of Rotenberg, 1978, I wish to avoid postulating ad hoc boundary symbol distinctions (though Rotenberg is more concerned with "boundary effects" in phonology, whereas I am here concerned with a morphological or word-formation distinction). I consider this notational device as little better than a trick, and await an explanation.

Finally, I elaborate on property (ii). The Auxiliary may begin a sentence if its first element is a polysyllabic base, i.e. kapu, etc., kalaka, kula, kaji, kuja, etc., yungu, etc. (including, note, yi, which must be followed by another Auxiliary element), or kala. The monosyllabic bases may occur clause initially, or after a hesitation, but not at the beginning of an utterance and are more commonly cliticised to a preceding word. An Auxiliary beginning with a pronominal clitic is always cliticised to a preceding word, even if the pronominal clitic is polysyllabic. Even when cliticised, the Auxiliary often initiates a stress foot on its first syllable<sup>12</sup>, and will fail to do so only when a polysyllabic element

<sup>10</sup> If a given slot is empty, there is nevertheless a meaning associated by virtue of paradigmatic contrast. Thus, in the absence of an overt pronominal clitic, the interpretation '3rd person singular' is available, there being no overt marker of this category (except the Dative rla) -- see 7.5.

<sup>11</sup> Mary Laughren first suggested to me that the Auxiliary is formed with by processes quite different from normal word-formation or encliticisation so that it simply has no "slot" for enclitics to appear in.

<sup>12</sup> This property is captured by assigning a "degenerate foot" to the first element of the Auxiliary, if it is a monosyllable -- see 3.6.3.

begins the second syllable of the Auxiliary.

### 2.7.2 DIRECTIONALS

There are four common morphemes which have combinatory possibilities intermediate between those of inflexions and enclitics:

rni	'hither, towards speaker'
rra	'forth, away from speaker' (or perhaps 'thither', Hale, 1974:13)
mpa	'past, by, across'
yi	'Continuative, keep doing' (see Granites, 1976:8)

These may attach to (i) an inflected Verb, or (ii) a productive Preverb (but not a "Dative adjunct" Preverb), as listed in 2.6.4.1. The morpheme yi is included here even though it is not semantically a "directional" because it shows the same combinatory properties.<sup>13</sup>

There are textual examples of rra on Preverbs which are not really of the productive type -- see paarrpa-rra ... pardi in 2.6.5, and rii-rra pi-nyi in 3.2.

I propose that the lexical entry of these four "directionals" have the context:

$$]_{[-N,+V] \text{---}}$$

which shows the intermediate nature of these morphemes -- one labelled bracket, and one unlabelled bracket.

This context frame for "directionals" not only predicts correctly that the only affixes which may follow them are the enclitics, but also that the longer, augmented allomorph of consonant-final Preverbs is the only one which may host a "directional", provided we accept the account of Preverb "splitting" of 2.6.5. See the example paarrpa-rra-yijala in 2.6.5, which illustrates both these properties.

Finally, mention might be made here of two further properties of these "directionals". First, there seems to be a preference for the

---

<sup>13</sup> Hale has argued that yi is historically descended from an element with a spatial rather than temporal meaning, which would complete the above group of four directionals, and exactly parallel the semantic distinctions in the Case suffixes, 2.3.2. (Talk, "Coincidence: a Warlpiri semantic category".)

"directionals" to attach to the longer, mi, NonPast form of VI Verbs, rather than to the root form (see the paradigm in 2.5). However, the short alternant has been recorded hosting a "directional":

... yinga-pala nyina-yi yarlpurru-rlangu.

Causal-33 sit-Cont age mates- e.g. (Hale, 1966:998)

'...since they (Dual) are still age-mates, for example'

and see mujumuju-jarri-rra, quoted at 3.2 (6). Cf. 4.4.2(iv)(61),(65).

Second, the morpheme rra, with the same meaning as the "directional", has been observed in a context not yet mentioned, viz. on an Infinitive, following a Complementizer:

Pararri -- ngula ka ngapa wanti-nja-rla-rra-puru karri.

rainbow that Pres rain fall-Inf-Seq-forth-while stand(NPast)

'A rainbow -- that exists when rain has passed'

(Definition in Warlpiri dictionary)

This is reminiscent of the Pure Obviative Complementiser rlarni (2.3.3.2) which appears to involve, at least etymologically, the "directional" rni added to the rla Sequential Complementiser. This, too, has been observed with a following Complementiser:

... ngurrju-ngkarni-karra

good-Pure Obv-Prox

'when [they] were well-behaved..'

(Yuendumu tape, 1979; Big Willie Japanangka)

I mention these examples for completeness, but do not incorporate them into the rules of word-formation, for they are quite unusual usages and may even be set expressions.

However, the directional enclitics (at least, the spatial three) sometimes occur between an Infinitive and Complementiser, as in the following examples:

Marlu-rna pantu-rnu parnka-nja-rni-karra-rlu.

'roo-I spear-Past run-Inf-hither-Prox Comp-Erg

'I speared a kangaroo while I was running this way'

Marlu-rna pantu-rnu parnka-nja- $\left\{ \begin{array}{l} rni \\ rra \\ mpa \end{array} \right\}$ -kurra.

'roo-I spear-Past run-Inf- -Obj Comp

'I speared a kangaroo as it was coming/going/running past'

Ngarrka-ngku kuyu nga-rnu, wirlinyi-jangka ya-ni-nja-rni-warnu-rlu.  
man-Erg meat eat-Past hunting-Result go-Inf-hither-Result-Erg

'The man ate the meat, having returned from hunting'

In the light of these examples (and cf. examples in 2.6.2), it appears that the context frame for the directional enclitics is in need of amendment, to show category information on the right-bracket. A possible revised context frame is the following:

$$] [+V, <+N> ] \text{----} ] [+V, <+N> ] \quad .$$

The revision also allows these "enclitics" to attach directly to Infinitives without their being regarded as Preverbs; and at the same time detracts even more from their status as enclitics. The only clitic property directionals exhibit, in the revised view, is the ability to attach to words of more than one part of speech, and the fact that the part of speech information is "transparently" passed through the enclitic.



In this chapter, a binary distinctive feature system is provided for the segments of Warlpiri. These are used to state the morpheme structure conditions, and to state the few segmental rules (mainly optional deletions) of Warlpiri phonology. Finally, the two phonological processes of a prosodic nature are analysed: vowel assimilation, and stress.

### 3.1 DISTINCTIVE FEATURES

Warlpiri has three vowels (the only possible syllabic nuclei), which bear the following features:

	<u>i</u>	<u>a</u>	<u>u</u>
high	+	-	+
back	-	+	+
round	-	-	+

In addition, each vowel can be long or short. Underlying long vowels are (with few exceptions) restricted in their occurrence to the first syllable of Nominal and Preverb roots. Minimal pairs for each vowel are :

parlpa	'old man'
paarlpa	'calf of leg'
ngurrpa	'unknowing, ignorant'
nguurrpa	'throat'
mirnta	'influenza'
mirta	'narrow hardwood shield'

As these examples show, the long vowels are represented orthographically by a sequence, i.e. an identical pair of vowels. This is also phonologically accurate in that a syllable with a long vowel is "bimoric", as witnessed by its role in the syllable-counting rule of allomorphy (2.3.4) and (less clearly) in stress placement (3.6.3). However, there are no underlying sequences of (non-identical) vowels.

The assignment of the feature [+back] to a is not crucial and in fact some of its allophones are front, and phonetically it is "typically rather central" (Hale, 1973b:406n8).

The feature [labial] may also be used here to distinguish the rounded vowel u, as well as for the bilabial consonants, after Hyman, 1975: 53-54 and the references cited there. There is a linking convention



from the stops; I follow the reasoning of Chomsky & Halle, 1968:318 in classing the flaps as continuants. Only western (Y) dialects have rd.

(ii): Hyman, 1975:47, 244 assigns retroflexes to [-high, +back] as is done here. Paul Kiparsky has argued, on the basis of evidence from palatalisation processes assembled by D.N.S. Bhat, that retroflexes are [+high, +back] (at least, those that inhibit palatalisation in certain languages). Such an assignment also explains the non-existence of "palatalised retroflexes"; assuming "palatalisation" of non-velars to be the specification of [+high]. However, if palatalisation on non-velars is best represented as the specification of [+high, -back] (as in the process undergone by Russian dark l in a palatalising environment), then the non-existence of retroflexes with a secondary palatal articulation would follow.

(iii): [anterior] is not needed to distinguish the segments of Warlpiri -- I have included it merely to show the specifications for it. Nor is [distributed] needed within the Warlpiri inventory. It is perhaps more evident in languages with an additional laminal series (the lamino-dentals), found in many Australian languages but not in Warlpiri. But even in those languages apicals can be distinguished from laminals just as well by using [high]: apicals are [-high], laminalo-alveopalatals are [+high], all are [+coronal] taken together, as opposed to the remaining [-cor] (bilabials and velar) consonants. Incidentally, this use of [high] is support for the assignment of the retroflexes to [-high], cf. (ii) above. But [distributed] is also justified because of the natural class it captures. In Warlpiri this comes up in the morpheme structure condition 4(b) (3.2); the [+dist] consonants are those which may follow an apical in a consonant cluster.

### 3.2 MORPHEME STRUCTURE CONDITIONS

Although all Warlpiri morphemes have much phonotactic structure in common, it is helpful to distinguish three types of morpheme so that the morpheme structure conditions can be presented more accurately. These are:

- (i) nominal and verb stems, derivational suffixes, Modal Particles, Conjunctions. All of these roots are bounded by category-labelled brackets, a right- or left-bracket on the left and a right-bracket on the right, as [maliki]<sub>N</sub> etc. or ]<sub>N</sub>pardu]<sub>N</sub> etc.

(ii) certain bound roots discernible in the shorter allomorphs of some Preverbs and attributive Nominals, such as; 68

<muly, [mulypari]<sub>N</sub>> 'footprint', [mulymuly]<sub>PVB</sub>,  
[liwarr]<sub>PVB</sub>, etc.

(iii) inflexional suffixes and enclitics, which have a right-bracket ] on the left and on the right (unless they are clitics within the Auxiliary system, which are devoid of category brackets), such as:

] [+C]ngku] ARG 'Ergative',  
]juku] 'still'  
-nku-lu- '2nd person plural subject'

The distinctions between these classes of morphemes show up mainly in the CV-template which they conform to, but not in the details of the segment possibilities beyond specification as "C" or "V".

Thus morphemes of the first type all have this structure (with first vowel possibly long):

(i) (C V (C))<sup>n</sup> C V                      n a positive integer.

In fact, known morphemes have n ranging from 1 to 3, except for certain reduplicated forms, and some names and fauna terms, in which n takes a higher value. Examples:

járnamiljárnpa                      'generation moiety term'  
júwayikirdi                      'babbler (bird sp.)'

Morphemes of the second type differ from those just mentioned in that they may be consonant-final, and may be monosyllabic. They have the structure:

(ii) (C V (C))<sup>n</sup>                      n a positive integer.

Furthermore, most consonant-final morphemes have an allomorph which fits the pattern of (i) above. This is the form augmented with pa, as in wuruly ~ wurulypa 'in seclusion' -- see 2,6,5. This augmented form thus has the structure:

(ii') (C V (C))<sup>n</sup> . p a                      n a positive integer

which is clearly subsumed under the structure (i) above. This generalisation extends to the possible consonants which can occur finally in a morpheme of type (ii) (viz, coronal nasals and laterals and the apico-alveolar flap rr). These are just the consonants which can generally occur before a non-coronal stop, (p can also be preceded within a morpheme by an m, which does not occur finally in type (ii) morphemes,) Hence there is a reason for not recognising a morpheme boundary before the augment pa. In this account, the restriction on possible type (ii) morpheme final consonants will follow from the fact that a type (ii) morpheme which is consonant final has an allomorph (with no internal boundary) with the pa augment, and the augmented form will naturally be included in general remarks about morpheme-internal clusters. The one loss incurred in such an approach is that it does not imply that consonant-final type (ii) morphemes never end in -m (a fact which has a ready historical explanation -- see Hale, 1973b:449-55).

Type (ii) morphemes which are not consonant-final may nevertheless consist of a single syllable, even though they have no augmented allomorph. These are all non-productive Preverbs, and all have a long vowel, viz. the Preverbs in:

jaa-karri-mi	'to be agape'
juu-karri-mi	'to be pointed upwards'
ngii-pi-nyi	'to brush it off -- dirt on body'
raa-pi-nyi	'to push it aside'
raa-parnka-mi	'to clear, of sky'
rii-pi-nyi	'to smoothe it'
ruu-ka-nyi	'to push it'

These cannot be augmented, even when in environments where a consonant-final Preverb would have to be, as in:

...jarnti-rni ka, jarnti-rni, kaninjarra rii-rra pi-nyi ...  
 trim-NPast Pres trim-NPast down smoothe-forth act on-NPast  
 "... he trims it, trims it, smoothes it [woomera] down ..."  
 (Hale, 1966:952)

Hence we do need to recognise a special morpheme structure possibility for type (ii) Preverbs, viz.:

## C V V

additional to that which is given by the structure of type (i) and the pa augmentation lexical rule.

Inflectional suffixes, and enclitics of the third type mentioned above, are the only Warlpiri morphemes which may have two consonants initially. They have this general structure;

$$(iii) \quad (C \ (C) \ V)^n \quad \quad \quad \underline{n} \text{ a positive integer}$$

None involve a long vowel. The morphemes with initial consonant clusters are:

(iiia) enclitics (2.7)	mpa	'past, across, by'
	lku	'and then, now'
	lpa	'Imperf Aux base'
	aku ~ npa	'2nd person subject'

(iiib) nominal inflexions<sup>1</sup>

ngku ~ ngki	'Ergative case'
ngka	'Locative case'

## (iiic) verbal inflexions (2.5)

nja	'Infinitive' (orthographic reduction of <u>nyja</u> )
ngka ~ nja ~ nta	'Imperative'

Since these morphemes can never begin a word, they are not subject to the restriction on word-initial consonants (constraint (2) below) as can be seen by apico-alveolar initial nku ~ npa, lku, lpa in (iiia) above, or number-marking clitic lu 'plural subject'.

To conflate the three morpheme structure restrictions just presented, the constraints (ii) and (iii) are best seen as additional riders on the general template given by (i). This may be seen by repeating the morpheme structure constraint of (i), with the first syllable taken outside the scope of the variable integer:

<sup>1</sup>If the nominal formative -nji ~ -nju (2,3,1,3(ii)(b)) were recognised as a morpheme, its shape would necessitate it being type (iii), but it is clearly neither an inflexion nor an enclitic.

(i) C V (V) (C) (C V (C))<sup>m</sup> C V    m a non-negative integer

then, as has been discussed, the type (ii) constraint is obtained by deleting the final "C V" from this template (and by requiring the first vowel to be long if m=0). And the type (iii) constraint is obtained by deleting the initial "C V (V)" from this template. The formal device for achieving this is the angle-bracket pair, with indexed conditions:

GENERAL MORPHEME STRUCTURE CONDITION:

(1) <CV(V)><sub>a</sub> (C) (C V (C))<sup>m</sup> <C V><sub>b</sub>    m a non-negative integer

Conditions:    b if type (i) or type (iii)

a if type (i) or type (ii)

The distribution of long vowels deserves comment. Non-initial long vowels occur, with rare exceptions, only in nominals and Preverbs that are reduplicated -- see 4.1.3. This distribution is understandable in historical terms -- most long vowels descend from monosyllables which underwent lengthening before pa-Augmentation (as discussed in detail by Hale, 1973b:449-55). Other modern long vowels are due mainly to borrowings (e.g. kuurlu 'school'), though a few are the result of reduction of a vowel-glide-vowel sequence (as in one of the rare examples of non-initial long vowel, pirlaali 'ritual friend of initiate', which occurs also as pirlawali in the speech of some), or fusion of historical compounds (as seems to be the case in yardijiinypa 'large black ant sp.').

There are further morpheme structure conditions, which are best expressed by putting additional restrictions on the template (1) above.

(2) The first consonant in (1) cannot be an apico-alveolar<sup>2</sup>, and cannot be ly word-initially.

<sup>2</sup>The non-occurrence of initial apico-alveolars as stated in (2.1) licenses the orthographic convention of neutralising the distinction between apico-alveolars and apico-domals word-initially (and also initially in derivational affixes in the writing of some; even -rlangu, an enclitic 'for example' is written -langu (with hyphen retained) by some). The neutralised symbol is the one otherwise used for the apico-alveolar, ie, with the "r" dropped. Thus initial rt, rn, rl are written "t, n, l" respectively.

The logic of this was carried over to the apico-domal flap rd, which was written "rr" by Lothar Jagst, and in Hale, 1974. However, this practice was abandoned by subsequent literacy workers and it is now written "rd", and constitutes an exception to the convention just mentioned.

Hence the occurrence of words throughout with an initial "t, n, l" is a consequence, not a counterexample, of (2).

This restriction is best stated negatively, that the first C in (1) cannot be \*[+cor, -high, -back]. The restriction on ly is not capable of any revealing incorporation into other generalisations, It is found morpheme-initially not on any root or productive derivational affix, but only on some formatives and reduplication partials, all known examples of which are listed here:

mungalyurru	'early morning' (cf. <u>munga</u> 'night')
yukalyurru	'early morning' (cf. <u>yuka-mi</u> 'enter, set')
kurdulyurrulyurru-pi-nyi	'to start to rain' (?) (cf. <u>kurdu</u> 'small raincloud')
yirntilyapilyapi	'butterfly'
jiwilyirriyirri	'blue and white wren'
pilyirriyirri	'bridge of nose'
malyurrulyurru	'red breasted finch'
ngalyurralyurru	
yulyurɣpulyurru	'early winter' (cf. <u>yulyurru</u> 'winter')

(As discussed in 4.1.2, the last couple of examples here may be given an underlying representation of the shape X-X and then subject to an internal deletion, with no evidence then for a morpheme boundary before the ly.)

The absence of word-initial ly is perhaps not an accidental gap: note luku-lyuku 'emu bush', which looks like a reduplication of \*lyuku.

There are restrictions on possible consonant clusters morpheme-internally, which I summarize from Hale, 1977:10. Morpheme-internal clusters are of two consonants (as may be deduced from the MSC above). The possible pairs are:

- (3) (a) a nasal (or lateral) followed by a stop, where the pair are homorganic, or a coronal followed by a non-coronal, or an apical followed by a laminal.  
 (b) rr followed by a non-apical stop or a non-coronal nasal.  
 (c) a coronal nasal followed by a non-coronal nasal.

There are also "rare instances" of lw and rrw (as in kalwa 'egret, heron, crane', rdarrwarlpari 'white in appearance', kurrwa 'old time stone axe'), but otherwise glides do not enter into clusters, nor does rd for reasons to be mentioned under (6).

Now rr joins with nasals and laterals in the natural class [+cons, +son]; and joins with nasals in the natural class [+cons, +son, -lateral];



and thus the combinatory properties of rr expressed in (3) (b) can be made to follow from slight generalisations of (3)(a) and (3)(c). In this view, rd would pattern with rr, since both are apicals, and its actual absence from clusters is thus an accidental gap, a consequence of its recent development in the history of those Warlpiri dialects which have it.

Thus the restrictions (3) may be stated in terms of features as follows:

- (4) In an intramorphemic consonant cluster  $C_1C_2$ ,  $C_1$  is [+son],  $C_2$  is [-cont], and the consonants have these implicational relations between their features:

$$(a) \quad \begin{bmatrix} C_1 \\ \alpha\text{cor} \\ \beta\text{high} \\ \gamma\text{back} \end{bmatrix} \quad \begin{bmatrix} C_2 \\ \alpha\text{cor} \\ \beta\text{high} \\ \gamma\text{back} \end{bmatrix} \quad (\text{ie. are homorganic})$$

$$(b) \quad \begin{bmatrix} C_1 \\ +\text{cor} \\ <-\text{high}>_b \end{bmatrix} \quad \begin{bmatrix} C_2 \\ -\text{son} \\ <+\text{cor}>_a \\ +\text{dist} \end{bmatrix} \quad a \supset b$$

(ie., coronal plus non-coronal, or apical plus laminal)

$$(c) \quad \begin{bmatrix} C_1 \\ +\text{cor} \\ -\text{lat} \end{bmatrix} \quad \begin{bmatrix} C_2 \\ -\text{cor} \\ +\text{nas} \end{bmatrix}$$

Single intervocalic consonants are not subject to any restrictions, except for certain gaps in the distribution of rhotics, which will be described along with word-level regularities below.

There is a regularity in the distribution of vowels in Warlpiri morphemes:

- (5) There are no underlying intramorphemic i C u sequences, except where C is p or w. In verbal stems there are no i C u sequences at all, and u C i sequences occur only in three verb stems.

Thus, morphemes with a i followed in a later syllable by an u have an intervening:

- (i) labial, as in the Nominals:

<u>pipipuka</u>	'bereaved father (used by classificatory mother to the bereaved)'
<u>yirriwu</u>	'Acacia ancistrocarpa (bush)'
<u>wirntirrpuru</u>	'bullroarer'
<u>kajipu</u>	'inside of bush coconut, <u>kanta</u> '
<u>karipurdanji</u>	'on other side, over'
<u>yuriwurrnyu</u>	'kindling wood'
<u>ngirntiwurarri</u>	'dragonfly', (perhaps from <u>ngirnti</u> 'tail')
<u>ngirntiwuluwulu</u>	'smoke sent up from signalling fire'

and the Preverbs:

<u>mirntipuru</u> -jarri-mi	'stay too long in one place'
<u>nyinjiju</u> -nguna-mi	'sleep late'

(There are no examples with m intervening.)

(ii) a vowel, as in:

<u>jinjiwarnu</u>	'crimson chat (bird sp.)'
<u>jipilyaku</u>	'water bird'
<u>miyalu</u>	'stomach'
<u>pirtirawurawu</u>	'long winter's night'
<u>yijardu</u>	'true'
<u>yirntatu</u>	'emu hunting blind'
<u>yirraru</u>	'homesick, lovesick'

and many more.

Among the over a hundred verb roots (see Appendix), there are none with u in syllable immediately following a syllable with a or i; nor do any roots end in u underlyingly (except perhaps those of pi-nyi and yi-nyi -- see 3.4). The three verb stems with two different high vowels are :

<u>nyunji</u> -rni	'kiss'
<u>yurirri</u> -mi	'move, stir (intrans.)'
<u>yururri</u> -mi	
<u>ngurntirri</u> -mi	'scold, growl at'

Only five verb stems have an i in a syllable preceding a syllable with an a:

jija-mi	'succumb to, be beaten by'
nyina-mi	'sit, be'
yilya-mi	'send'
mila-rni	'choose, select best one'
yirra-rni	'put, place'

There are many non-Verb morphemes with u in a syllable immediately preceding a syllable with i. Examples include:

jalurti	'crest-tailed marsupial mouse'
kurriji	'wife's mother'
munikiyi	'native bee'
pukurdi	'pigeon's top-knot; hair-bun'
punjungiyinyi	'incipient beard'
wakurnji	'armband'
yukiri	'green, alive'
yurdi	'tree top'

The counterexamples to (5) come: (i) across reduplication boundaries, but these are like boundaries between elements of compounds for morpheme-structure purposes, and are no real exception; and (ii) in loan words of recent origin,<sup>3</sup> such as miyurlu 'mule' (Hale, 1966:764) and perhaps minyura 'woman's headdress'.

These restrictions on high vowel distribution within morphemes extend to the word level through the operation of the two rules of vowel harmony (3.5).

There is dialectal variation within Warlpiri as to which high vowel is used in certain Nominals. The tendency is apparently for the u vowel to be preferred in dialects in the east of the Warlpiri area, and the i in the west, though there are a number of pairs which show the opposite preference. Furthermore, adjacent, genetically related, languages<sup>4</sup> show

---

<sup>3</sup> Compare the Warlpiri pronunciation Pintipuyu of the name of the neighbouring Pintupi people. The Warlpiri names of two other of their neighbours show the force of (3) above: Warnmanpa 'Warlmanpa', Mulpurra 'Mutpurra'.

<sup>4</sup> I have investigated only Pintupi cognates, using Hansen & Hansen, 1977, but since Mutpurra also has iCu sequences (e.g. wituru 'forehead', from Hale's Mutpurra notes) it and other languages should be investigated to add to the examples given here.

cognates with some of the Warlpiri Nominals which show only one of the high vowels. Some examples of various types are presented in the following table:

<u>Pintupi</u>	<u>Yuendumu Warlpiri (Y)</u>	<u>Eastern Warlpiri (H)</u>
japujapu 'ball'	japujapu 'entwined'	japijapi
jiwurru 'kindling'	jiwirri	jiwirri
kurtiji 'shield, etc'	kurdiyi	kurtuju
purli 'stone'	pirli	purlu
murti 'knee'	mirdi, murdi	murtu
yunturrkulyu	yurnturrkinyi	yurnturrkuny
'large snake sp.'	'black-nosed python'	
pilurru 'spirit'	pirrirra	pirrirra
pikurru 'woomera'	pikirri	pikirri
-- 'rat kangaroo'	purdujuru	purdirri (L)
kilyulkilyulya	kirlilkirlilpa	kirlilkirlilpa
'galah (bird sp.)'		

(The Warlpiri glosses are the same as for Pintupi unless otherwise shown.)

These patterns suggest that the forms with two different high vowels, as in Pintupi, continue the more ancient vowels, with levelling applying in the history of Warlpiri. There has apparently been more than one historical process at work, and this topic cannot be pursued here. It is interesting to note that the Arandic languages, to the east of Warlpiri, have eliminated the phonemic distinction between the high vowels, and have an underlying two-vowel system (with also a length distinction) -- see, for example, Breen, 1977, and unpublished work by Avery D. Andrews.

Finally, some generalisations can be made about the distribution of rhotics in adjacent syllables. I start with the observation:

- (6) In a C V C sequence, both consonants are not identical rhotics (ie. rr, r or rd).

Two possible exceptions to this are :

yurrurru	'big pile of firewood stacked up to make sufficient coals to cook big game'
kurara	'prickly hardwood sp., Acacia tetragonophylla'

Laughren, 1978:15n7 has found evidence of "a diachronic rule of R dissimilation" in that the -rra formative in various directional terms appears as -ra in kakarrara 'east' (cf. kakarra-rni 'from the east', etc. and yatijarra 'north', yatijarni 'from the north', and so on). Note also the semi-patrimoiety term wurruru, cf. Kuurinji wurrurru.

The only known environment meeting this rule's structural description in modern Warlpiri is when the directional clitic -rra 'forth' follows a Preverb or Verb whose last syllable begins with rr. The dissimilation does not apply in such cases. Thus:

rarra-rra ka-nyi	'drag forth'
mujumuju-jarri-rra	'spread out (of creek)'

The absence of a rdVrd sequence, included in the statement (6), is a direct consequence of the recent historical development in western Warlpiri of rd from some \*rt's, according to the process:

$$*rt > rd \quad / \quad \left. \begin{array}{l} \# \\ \vee \end{array} \right\} \text{--- } V ( C \quad X ) \#$$

$$\left\{ \begin{array}{l} [-\text{back}] \\ [+high] \end{array} \right\}$$

ie. "an initial or intervocalic \*rt became a flap except when the next consonant was a retroflex".

This development is discussed in Hale, 1977:10-11. An example showing both the application and the inhibition of the change is:

\*kartirti > kartirdi 'tooth'

This process is not applied to loan words borrowed since the change took place: thus

yarti 'yard'	nyirtinyirti 'wood borer'
karti 'card'	mirtimirti 'bung eye'
wapirti 'yam sp.' (probably from Pintupi <u>wapurti</u> )	
mirta 'narrow shield type'	Kartiji 'Kaititj people'
manirtirrpirtirrpipi 'mulga bird'	(also <u>Ngardiji</u> )

Perhaps the change was inhibited for onomatopoeic reasons in martinymartinypa 'dangerous lightning', or tiyirti - tiyartiya 'magpie lark, mudlark'.

Some speakers have however retained alternations in a Verb stem that

marda-ka		marta-rnu
have-Imp	but	have-Past

However, this has not been observed with nominals:

lungkarda		lungkarda-rlu
blue-tongue lizard	and	-Erg

### 3.3 CLUSTER SIMPLIFICATIONS AND THE SYLLABLE

The canonical syllable shape in Warlpiri is CV(C) (or CV(V)(C) in word-initial syllables) as can easily be seen from the morpheme-structure constraint (1) in 3.2. There is however not much evidence of processes in Warlpiri that make use of this unit. As with any metrical process, the stress rules (3.6) are proposed to build a metrical structure which includes as terminal nodes of feet the unit "syllable", but this is done from universal considerations. Reduplication may be seen as providing slim evidence for the syllabic unit, but in the treatment below the morpheme and the foot are used instead. Loan phonology may provide some evidence, but this also involves application of certain of the morpheme-structure constraints as given above, and most of those operate between consonants in adjacent syllables, i.e. from one syllable to another. Certain suffixal allomorphy is governed by counting the mora of the stem (the Ergative and Locative and suffixes built on the Locative -- see 2.3.4).

Intermorphemic consonant clusters are simply those that result from stringing together morphemes each of which conform to the morpheme-structure constraint. This means that there are some clusters which can occur only at morpheme boundaries, viz.:

coronal nasal, rr, lateral - rn, ny, rl, rd, or a glide

lateral - m, ng

l - rt, ly - rt, n - rt, ny - rt.

(where here a hyphen denotes the boundary)

Since some type-(ii) morphemes (see 3.2) can end in a consonant, and some type-(iii) morphemes can begin with a cluster of two consonants, it might be thought that they would combine to produce intermorphemic clusters of three consonants. In fact this does not happen. When a consonant-final Preverb takes an enclitic (typically, the directionals, including mpa

'across'), the augmented allomorph of the Preverb is chosen (see 2.6.5).

An example is:

juurl-pu-ngu-mpa  
 juurlpa-mpa pu-ngu                    'jumped across'  
 \*juurl-mpa pu-ngu

as discussed in Hale, 1973:453-55.

Some of the clusters listed above do however simplify (with various degrees of optionality) by deleting the second member.

CLUSTER SIMPLIFICATION

$$\begin{bmatrix} -\text{syll} \\ +\text{cont} \end{bmatrix} \rightarrow \emptyset / C \text{ ---+ , optional.}$$

The morpheme boundary in the environment is redundant insofar as continuants cannot be the second member of an intramorphemic cluster. The rare lw and rrw clusters are not subject to simplification by this rule.

The examples in Hale, 1974 and 1977:10 exhibit simplification of the following clusters:

- (a) rl, l, rr, ny                    -    w
- (b)                    rr, ny, rn, ly       -    y
- (c) rl,                    rn, ly       -    rl

The rule also predicts deletions of r and rd. The former deletes in the reduplicated form:

ramparl - (r)amparl    from the Preverb ramparl 'by mistake'

but the latter apparently does not, e.g.:

rdimpirl-rdimpirl-pi-nyi    'perform clapping boomerang accompaniment style'

Examples to test this are uncommon. An example showing the deletion occurring in a reduplication and between a Preverb and verb root is:

wapal-(w)apal-(w)apa-mi    'to walk about in search of'

See also the deletion rule applicable in certain reduplications, 4.1.2.

There is another process of cluster simplification apparent in the speech of some, particularly in rapid speech, where the morpheme-initial clusters lpa 'Imperfect Auxiliary base' and lku 'then, now' appear as pa and ku respectively.

In baby talk, and the speech of adults imitating babies, the non-nasal sonorants are missing before stops; and also in such speech r and rd may appear as y or w. Thus:

<u>adult form</u>	<u>baby-talk</u>
ngurrju 'good'	ngu(u)ju
pirrjirdi 'heavy, hard, rigid'	pijirdi ( <u>pijiyi</u> in adult imitation)
purlka-pardu 'dear old man'	puka-pawu
Japangardi (subsection)	Japangayi
Japaljarri (subsection)	Japalayi
-kari (suffix)	-kayi

These examples by no means exhaust the range of this unstudied phenomenon. This, with loan phonology, and songs and other possible speech styles or perhaps word-games, constitute the areas of Warlpiri segmental phonology that may well provide further synchronic evidence for phonological analysis in Warlpiri. Otherwise, the account in this chapter is a reasonably complete survey of Warlpiri segmental phonology.

### 3.4 VOWEL ASSIMILATIONS

This section and the following one present the various assimilation processes which involve the two high vowels of Warlpiri. Apart from the minor (local, optional) deletion rules (3.3, 4.1.2), these processes account for all the phonological alternations in Warlpiri.

The account here is a revised version of that in Nash, 1979. It relies particularly on Hale's, 1973b:405-11 discussion of the harmony rules in comparative perspective, and Hale, 1977:20-23.

Vowel assimilation in Warlpiri is apparent from alternations between the two high vowels. The low vowel a shows no alternation. The types of assimilation can be classified as follows:

#### (1) local

(1) in the paradigms of pi-nyi and yi-nyi

(ii) i → [u] in the two clitics rni and rli when on a word ending in u

#### (2) harmony (i.e. propagating, non-local)

(i) u → [i] in suffixes and enclitics, following a stem i

(ii) i → [u] in verb roots, preceding an inflexional u

The assimilations (1) are described in this section, and the two harmony



processes in 3.5.

(1) REGRESSIVE ASSIMILATORY CHANGE OF u TO [i]

This assimilation is quite restricted, occurring in the paradigm of just two verbal roots, i.e.

pi-nyi	NONPAST	pu-ngu	PAST, NOMIC
pi-nja	INFINITIVE	pu-ngka	IMPERATIVE
[pin t a]		pu-nganya	PRESENTATIONAL PRES
		pu-ngku	IMMEDIATE FUTURE

of pi-nyi 'hit, kill, bite'; and of yi-nyi 'give'. This alternation may be described by the rule:

$$(1) \quad u \rightarrow i / \quad ]_{\underline{v}} + \begin{matrix} +\text{high} \\ -\text{back} \end{matrix}$$

There is no need to restrict it further, since there are no other verb roots ending in u.

Verbal inflexions which are bilabial or apico-alveolar in their first segment do not happen to combine with the roots in u. The rule (1) must be restricted to verb roots, however, as other roots with final u show no alternation before suffixes beginning with a palatal: e.g. ngaju-nyangu 'my, mine', ngurrju-nyayirni 'very good', kuyu-jangka 'meat-Elat' etc.

An alternative treatment assigns these two verbs an underlying i, and invokes a rule:

$$(2) \quad i \rightarrow u / \quad \text{---} ]_{\underline{v}} + \begin{bmatrix} +\text{back} \\ +\text{high} \end{bmatrix}$$

which capitalises on the fact that the only velar-initial verbal inflexions are in the 3rd conjugation, the one to which the two verbs in question belong. This claims that there has been a reanalysis at some point in Warlpiri's history (as these two verbs descend from \*pu-, \*yu-) and that as a result no Warlpiri verb root ends in u -- only a and i. (cf. 3.3). This morpheme-structure constraint is the only evidence to distinguish these treatments synchronically.

In any case, rules (1) or (2) are of such a restricted nature (applying in the inflexion of just two common verbs) that their "rule" status is quite marginal. A superior treatment of the alternation in these root vowels is likely to be found in the theory of inflexional morphology

which lists the inflected forms of these roots along with that root's lexical entry, along the lines of the approach in Chapter 2. 82

(ii) ASSIMILATION OF i TO [u]

This assimilation is the only one which exhibits dialectal variation: it is limited to the west and north of the Warlpiri area, in the main. (Hale, 1977:23). Furthermore, it produces alternations in just two morphemes: the verbal directional rni 'hither, toward speaker' (2.7.1) and the person/number-marking clitic rli, which occurs in three of the four non-singular 1st person subject markers (2.7.2). Thus there are alternations such as:

Parnka-ja-rni-rlijarra	'run-Past-hither-we Dual Exclusive'
yani-rni-rlijarra	'go- NPast'
yanu-rnu-rlujarra	'go-Past'
Minija -rli nya-ngu	'We (Dual Inclusive) saw the cat'
Maliki -rli nya-ngu	'We saw the dog'
Kurdu -rlu nya-ngu	'We saw the child'
Pina -rni ya-nu	'He came back hither'
Jawirri -rni kju-rnu	'(The horse) threw him and left, hither'
Wararrku -rnu parnka-ja	'It slithered hither'

There is an apparently similar alternation in the noun-formative nji — see 2.3.1.3. I hesitate to identify the treatment of nji with that of rni and rli above for two reasons: (a) nji is of limited productivity, whereas the enclitics attach to an unlimited class of words; (b) the alternations of rni and rli go together dialectally, whereas the forms like purunju, mururunju are found in all dialects -- noöne says \*purunji, or \*mururunji for instance. Since the stems in nji need to be given separate lexical entries (because of the restricted productivity, and some unpredictability of meaning), the explanation for the vowel alternation in these stems will be of an historical nature. On the other hand, the alternations of rni and rli require a synchronic rule, with the effect of:

(3)  $i \rightarrow u / u] C_0 \text{ ---+ } ; \text{ OBLIG, in some dialects only}$

As some of the examples above show, this rule has to be able to apply to its own output. In fact, it most likely applies cyclically, as for example in:

[ [yanu] <sub>v</sub> rni]	rli-jarra	
u		2nd cycle
	u	3rd cycle

The cyclic bracket ] in the left-hand environment of the rule (3) may turn out to be superfluous, in that its existence is deducible from the premise that the rule (3) applies according to the strict cycle and thus cannot apply within roots.

The morpheme boundary in the right-hand environment of (3) is needed to prevent the rule applying to polysyllabic suffixal morphemes with underlying i -- ones such as:

-pinkl	'etc.'
-pinangi(w)	'only, any'
-wiyi	'prior, first'
-mipa	'only'
-yijala	'also'
-kirli	'exactly'

which never occur in any alternant form.

Note that I am assuming that the clitics rlipa 'we Plural Inclusive' and rlijarra 'we Dual Exclusive' contain the morpheme rli, which is also the clitic 'we Dual Inclusive'. The lack of complete semantic compositionality here supports the decision of Hale, 1973a:325 to resist a synchronic bipartite analysis for them. But it does seem justified phonologically and distributionally. (The stress rule also needs to assume a morpheme boundary after rli in these clitics.)

Mention should also be made here of the evidence given by Hale, 1973b:407n10 that the restricted progressive assimilation of this section is relatively recent in Warlpiri, in that there are etymologically complex roots such as kalkurni 'towards speaker' (involving \*rni 'hither'), which do not exhibit the assimilation in the speech of those who would otherwise assimilate the vowel of rni to a preceding u. The continuative suffix yi, which patterns morphologically with the directionals such as rni (see 2.7.2), does not undergo the rule (3). Nor does the enclitic ji in the eastern dialects (ju in the western dialects does harmonize). This may be related to its initial palatal -- the only other palatal-initial monosyllable suffix with i is the formative nji just

discussed, and although it has an alternant nju this is not attributed to rule (3) synchronically.

In any case, the vowel assimilation described here, like that described in (i), is best seen as a local non-propagating assimilation rule.

### 3.5 VOWEL HARMONY

As mentioned at the beginning of section 3.4, there are two propagating vowel assimilation processes in Warlpiri. First I present the details of each of them, and then I bring together the common aspects of the two harmony processes and relate them to the general theory of harmony.

#### (i) REGRESSIVE ASSIMILATION OF i TO [u]

The Past inflexional suffix for 4 of the 5 conjugations has the form Nasal u, and this is also the shape of the Nomic which is homophonous with Past in these 4 conjugations and extends the ngu form to the remaining (1st) conjugation (see 2.4). All conjugations other than the 4th have at least one member that has a root-final i. When such verbs combine with the Past suffix the root-final vowel is [u]. For example:

<u>pangi-</u>	'to dig it -- ground; to scratch it deeply'
pangi-rni	'dig-NPast'
pangu-rnu	'dig-Past'
pangi-ka	'dig-Imperative'
pangi-ki	'dig-Immediate Future' (used only in the west) <sup>5</sup> .

This applies to both i vowels in the root, if there are two:

<u>kiji-</u>	'to throw it, drop it'
kiji-rni	'throw-NPast'
<u>kiju-</u> rnu	'throw-Past'
kiji-ka	'throw-Imperative'

but not to an i or u separated from inflexion by an a:

---

<sup>5</sup>Note that the Immediate Future, for those speakers (in the west) who use it, shows Progressive Assimilation, of the type discussed in (ii) below.

<u>yirra-</u>	'to put, place'	<u>yurupa-</u>	'to grind'
yirra-rni	'put-NPast'	yurupa-rni	'grind-NPast'
yirra-rnu	'put-Past'	yurupa-rnu	'grind-Past'
yirra-ka	'put-Imperative'	yurupa-ka	'grind-Imperative'

Note also the paradigm of the roots with two high vowels: (cf. 3.2, (5))

<u>nyunji-</u>	'to kiss'
nyunji-rni	'kiss-NPast'
nyunju-rnu	'kiss-Past'
nyunji-ka	'kiss-Imperative'

The change of i to [u] also propagates through the derivational affix, the Inceptive, as in:

kiji-rni-nji-ni		kuju-rnu-nju-nu
throw-Incep-NPast		-Past
	but	
kiji-rni-nji-nta		
-Imp		

Thus this assimilation shows iteration of the regressive backing of the high vowels, and this iteration is blocked by an intervening low vowel. The low vowel a triggers neither backing nor fronting, as there are surface i and u in syllables immediately before syllables with a.

This regressive assimilation of i to [u] does not propagate further leftwards than the verb root. This is seen in examples of compound verb stems, formed with a Preverb before the verb root. For instance, from kiji-rni 'throw' as in the above example, is formed pirri-kiji-rni 'to scatter (trans.)'. This compound verb has inflected forms:

pirri-kiji-rni	NPast
pirri-kuju-rnu	Past
*purru-kuju-rnu	

and so forth. Thus the leftward propagation of backing of high vowels is sensitive to morphological structure here.

The domain of the harmony extends leftwards to the first left-bracket encountered, and thus does not penetrate a Preverb:

[ [pirri] <sub>PVB</sub> [kiji-rni] <sub>V</sub> ] <sub>V</sub>
[ [pirri] <sub>PVB</sub> [kuju-rnu] <sub>V</sub> ] <sub>V</sub>

This vowel assimilation process appears to be ordered before the verbal reduplication process (4.5), in the light of examples such as:

pangi-pangi-rni            'dig quickly-NPast'  
 pangu-pangu-rnu            'dig quickly-Past'

(Note that an intervening a otherwise blocks propagation of assimilation.) This is treated as a property of reduplication, rather than as an exceptional property of this regressive assimilation rule.

In a phonological theory which expresses assimilations such as these as iterative segmental rules, the process of this section would be written as Steriade, 1979:48, rule (10) has worked out:

$$(4) \quad [+syll] \quad [+back] / \rightarrow (C_o \begin{bmatrix} +syll \\ +high \end{bmatrix})^* C_o \begin{bmatrix} +syll \\ +back \\ +high \end{bmatrix} ] V\text{-Past}$$

Conditions: Obligatory, iterative, no occurrences of [ in right-hand environment.

It may be significant that the 1st conjugation Nomic Agentive ngu so far has not been observed for roots in i. Hale's consultant rejected "wurnpurlungu" (from wirnpirli-mi 'whistle') in favour of the approximately synonymous wirnpirlinjawitawangu, thereby "avoiding" harmony.

(ii) PROGRESSIVE ASSIMILATION OF u TO [i]

This assimilation is widespread in Warlpiri, affecting a large proportion of the nominal suffixes, and enclitics to any word. Consider the alternations in:

minija-kurlu-rlu-lku-ju-lu  
 cat -Prop-Erg-then-me-they  
 i.e. [ [ [minija]<sub>N</sub> kurlu]<sub>CASE</sub> rlu]<sub>ARG</sub> lku] -ju-lu  
 kurdu-kurlu-rlu-lku-ju-lu  
 child-  
 maliki-kirli-rli-lki-ji-li  
 dog-

Enclitics still show the alternation when added to verbs, as:

ya-nu-juku                    'went-still'  
 wanti-mi-jiki                'fall-still'  
 wanti-ja-juku                'fell-still'

and, as it happens, there is one verbal suffix with u which participates in this assimilation. The verbal suffixes with u are the Past (and Nomic) suffixes which trigger regressive harmony, as described in (i) above. The Immediate Future inflexions, with u, however, undergo progressive assimilation.<sup>6</sup>

Just as the propagation of the assimilation described in (i) is blocked by an a-vowel, so it is here -- thus:

maliki-kirli-kirra-lku-ju-lu

which involves the nominal case suffix kurra 'Allative', in place of the Ergative in the earlier example. The assimilation can also be triggered by a vowel in a suffix, as:

maliki-kirlangu-kari-kirli  
dog -Poss -other-Propriative

where the underlined vowels are underlyingly u but have assimilated to [i].

Certain intervening consonants also "appear to inhibit assimilation" (Hale, 1973, p.406n9), namely p and w. Examples include:

ngamirni-puraji MoBr -your	(u remains on surface)
ngamirni-ki-purdangka MoBr -Dat-same gen. kinsman	milpirri-puru cloud-during
miyi-ki-purda food-Desiderative	ngamirni-puka MoBr -only, even
wajirrki-puru wet time-during	karlarni-purda west-hither-wards

and the w of:

ngali-wurru 'you and I are the ones'  
12 -Emphatic

The generalization appears to be that a labial consonant blocks the propagation of this assimilation. Note, however, that there are no known suffixes containing an m (the only other labial) and underlying u

---

<sup>6</sup>Hale, 1977:34. This inflexion is in use only in south-western dialects, and Hale (p.c.) reports that in the elicited speech of a Warlpiri who does not normally use the inflexion, assimilation did not occur: thus ? panti-ku 'spear-Immediate Future'. This form is also aberrant in that it contains the sequence iCu (C not p or w) otherwise not found within a simple word.

following it, i.e. beginning mu.., just as there are no roots showing imu, as observed in 3.2.<sup>7</sup>

In a fashion parallel to that of the regressive harmony of section (i) above, this progressive harmony extends rightwards to the first left-bracket encountered. Thus, the harmony does not penetrate:

- (a) from a Preverb to a Verb stem or Preverb, as exemplified again by:

pirri-[kuju-rnu]

as quoted in section 2, and by examples such as:

piki(piki)-[turnu-jarri-mi]  
under threat-congregate-NPast

- (b) across a Nominal compound's internal boundary, including reduplications, e.g. (from 4.1.3):

[yukiri]-[yukiri] 'green'  
[kurdiji]-[kurdiji] 'shoulder blade'

and Nominal-Nomic Agentive compounds (2.4.1):

[miyi]-[kupu-rnu] 'food winner'

The harmony does, however, penetrate into an enclitic, including pronominal clitics.

This harmony rule has the same effect as the morpheme-structure condition (3.2) which prohibits a morpheme-internal iCu (except where C is p or w). It applies exceptionlessly, except that it does not apply to the few exceptional morpheme-internal iCu sequences, as in loans — thus it conforms to the restrictions of the strict cycle.

### 3.5.1 AUTOSEGMENTAL ACCOUNT OF VOWEL HARMONY

In this sub-section, I consider the two propagating assimilations of Warlpiri vowels in the light of the autosegmental theory of vowel harmony, and show how it explains a number of the properties of this process.

The autosegmental theory of vowel harmony is an extension, made in Clements, 1977a, of Goldsmith's autosegmental theory of tone and intonation.

---

<sup>7</sup> Mary Laughren (p.c.) has made the alternative suggestion that the blocking consonants are crucially [-cor,-high], and that, since all the vowels are [-cor], the blocking property is associated with the natural class [-cor,-high] = {a,p,w,m}.



It is a theory within the general ambit of metrical phonology (and morphology), the subject of much current research. See Halle, 1979 and the references given there.

A theory of vowel harmony has to explain the general properties of vowel harmony, which are summarised in Clements, 1977a:112 from work done in the Stanford Language Universals Project: (i) phonetic motivatedness, (ii) root control, (iii) bidirectionality (from root to prefix and to suffix), (iv) unboundedness, and (v) non-optionality. Warlpiri conforms to the general pattern, in that, considering these properties in turn:

(i) the normal vowel features [back], [round] or [labial], and [high] are the ones involved;

(ii) the harmonic category of the root determines the category of the suffix in the progressive harmony; and the regressive harmony, which is of the minority "stem ablaut" type, is triggered by certain affixes (or perhaps the grammatical category "Past");

(iii) the lack of prefixes in Warlpiri necessarily causes it to conform, vacuously, in respect of bidirectionality;

(iv) the propagation of the harmony is bounded only by a morphologically defined domain, and does not, for instance, count syllables;

(v) the harmony process applies obligatorily when its conditions are met.

Warlpiri vowel harmony has further properties which a theory needs to address: (vi) the two harmony processes are in some sense the "converse" of each other -- they involve the same features; (vii) the consonants which "block" the harmony do so only in the progressive, de-rounding, harmony, and have a natural relation to the harmonising feature(s).

Furthermore, Warlpiri harmony is "asymmetric" -- potentially harmonising vowels are underlyingly specified for the harmony feature. This property has been addressed by Steriade, 1979:44-45, who argues that the Warlpiri high vowels must be "fully specified for frontness in the underlying representation", because "the existence of segments blocking both harmony rules provides us with neutral environments, i.e. environments in which the surface frontness/backness of a high vowel cannot be due to the application of a harmony rule." Since both i and u are found in such environments, her argument continues, "in a distribution unpredictable by

any other means, then we must assume that the frontness/backness of these vowels is underlying. And if in some environments the high vowels must be assumed to be underlyingly marked as [+back] or [-back] then we have no reason left to think that this is not the case in all environments."

Clements, 1977a has developed an autosegmental theory of vowel harmony which recognises the "asymmetric" type.

There are languages in which root or affix vowels which must be lexically assigned to one harmonic category A shift to Category B in the presence of certain forms which are invariably of category B. Such harmony would result from a feature-deleting rule... (Clements, 1977a:116)

Warlpiri's genetic relative Nyangumarda (see Hoard & O'Grady, 1976) has vowel harmony of a type included by Clements in the "asymmetric" class. I propose to account for these types of harmony within this autosegmental theory, making one change from the approach adopted by Clements, which I presently indicate. Thus I adopt the following theoretical framework:

(a) Vowels are autosegmentally specified for certain features; in Warlpiri these are [labial] and [high], which, for the remainder of this section, I abbreviate as L, H respectively. These features are assigned to a separate, concurrent level or "tier" in phonological representations. The general notion of "projection" (Halle, 1979:vi, attributed originally to J.-R. Vergnaud) is available to formalise the concepts further if necessary.

(b) Autosegments are associated with segments by "association lines". Parallel to Goldsmith's original Well-Formedness Condition, there is a Well-Formedness Condition for vowel harmony (Clements, 1977a:113):

- (i) All vowels are associated with at least one harmony feature; all harmony features are associated with at least one vowel.
- (ii) Association lines do not cross.

"The Well-formedness Condition functions throughout the course of derivations, correcting ill-formed representations that may arise as a result of rule application." (ibid.)

(c) The Obligatory Contour Principle (originally due to Leben, and reformulated by him, for tone, as a simplification convention, in Leben, 1978:181), extended to vowel harmony, is added to Clements, 1977a.

This convention applies, like the Well-formedness Condition, throughout a derivation to correct ill-formed representations. The convention states that "Two identical adjacent autosegments merge to form one", and can be stated as a deletion of one autosegment under condition of identity with the other. (Note that Clements, 1977a does not use this Principle. I adopt it so as to avoid the use of iteratively or simultaneously applied rules, a rule type employed by Clements.)

Within this framework, then, typical Warlpiri Nominals have the following phonological representations:<sup>8</sup>

mini	ja	kur	du	mal	iki	yuki	ri	jalur	ti	luma
∨		∨		∨		∨				
-L	-L	+L	-L	-L	+L	-L	-L	+L	-L	+L
+H	-H	+H	-H	+H	+H	+H	+H	-H	+H	-H

Upon word-formation, the Obligatory Contour Principle applies to give underlying representations such as:

mini	ja	-kur	lu	-rlu	-lku	-ju	-lu	mal	iki	-kur	lu	-kur	ra	-lku	-ju	-lu
-L	-L	-L	-L	+L	-L	-L	-L	-L	-L	+L	-L	-L	+L	-L	-L	+L
+H	-H	+H	-H	+H	-H	+H	-H	+H	-H	+H	-H	+H	+H	-H	+H	-H

Similarly, the underlying representation of the Past form of typical Warlpiri Verbs is as follows:

pangi	-rnu	kiji	-rnu	yirra	-rnu	yurrrpa	-rnu
-L	-L	+L	-L	+L	-L	-L	+L
-H	+H	+H	-H	+H	-H	+H	+H

To such representations the harmony rules apply. Each involves a deletion of certain autosegments, followed by "a reassociation [which] proceeds outward in all such cases from the autosegment which was the conditioning element of the [deletion] rule." (Clements, 1977a:115) This reassociation is motivated by the Well-formedness Condition. The specific deletion rules, are , along with the choice of features out of which the autosegments are formed, all that needs to be stipulated about a particular language's asymmetric harmony.

<sup>8</sup> I omit the conventional square brackets [ ] from the feature bundles representing the autosegments, in the interests of typographical clarity. Furthermore, the vowels are formally not specified for [L] and [H] at the segmental tier. I am indebted to Nick Clements for suggestions incorporated into the following account, though he may not agree with the form they take.

The Warlpiri harmonic deletion rules are:

(i) for the regressive harmony

$$[-L,+H] \rightarrow \emptyset / \text{---} [+L]$$

|  
Past

(ii) for the progressive harmony

$$[+L] \rightarrow \emptyset / [-L,+H] \text{---}$$

For example, the underlying representations on the previous page are, subsequent to the harmonic deletions, represented as follows, where the dashed "----" association lines are the ones added by the Well-formedness Condition:

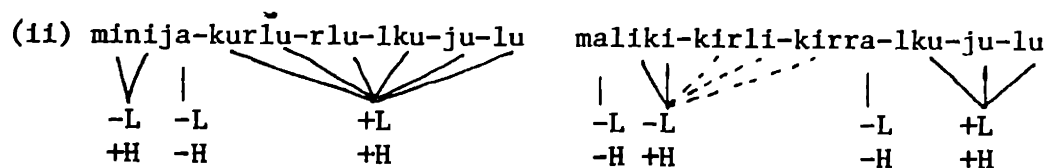
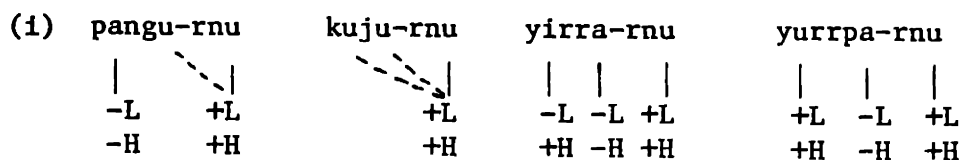

Notice how the autosegment  $[-L,-H]$  associated with a effectively blocks the operation of the deletion rules. Note also the formal similarity of the two harmonies -- both delete one of the autosegments in an adjacent  $[-L,+H]$   $[+L]$  pair.

The interaction of ɲ and w with the progressive harmony is accounted for by also representing these segments on the  $[L,H]$  tier. Thus the segments that are partially autosegmentally represented are those in the class  $[+syll] \cup [+labial]$ ,<sup>9</sup> and they are represented on the autosegmental tier for their values of  $[labial]$  and  $[high]$ . The segments p and w are  $[-labial,-high]$ , and so block the progressive harmony as in the following examples:

<sup>9</sup> The fact that this is not a natural class may be a drawback of this account, but at this stage of the development of the theory it would be premature to reject the account on this ground alone. See Nash, 1979 and Aoun, 1980 for proposed amendments to the metrical theory based on Warlpiri.

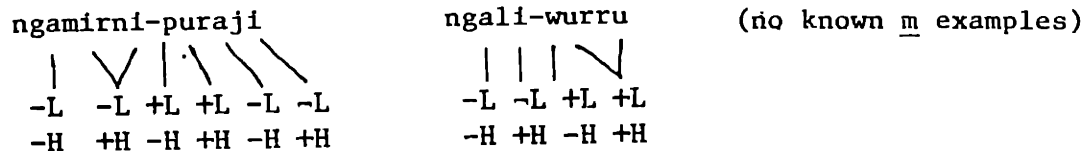

providing we make an additional assumption about how the harmonic deletion rule for the progressive harmony (ii) is to apply to such representations. Two possible assumptions come to mind: (a) stipulate that an autosegment associated with a [-syll] segment cannot be deleted (after the fashion in which Clements, 1977a:115 stipulates that the Spanish O[ral] autosegment cannot delete if it is associated with a [-son] segment); or (b) add to the structural description of the harmonic deletion rule the specification [+H], so that the rule would delete [+L,+H]. The latter assumption would detract from the parallelism between the two harmonies, unless the regressive harmonic deletion were similarly amended, i.e. to apply in the context /--- [+L,+H] (Past), an amendment which makes the wrong prediction about the interaction of p and w in the regressive harmony.

The rounding triggered by the regressive harmony is not blocked by the labial consonants. Verb roots with a labial consonant between two underlying i vowels show harmony through the stem, as in:<sup>10</sup>

yirрпи-rni 'insert-NPast'	kipi-rni 'winnow-NPast'
yurрpu-rnu 'insert-Past'	kupu-rnu 'winnow-Past'

These stems are represented phonologically as:

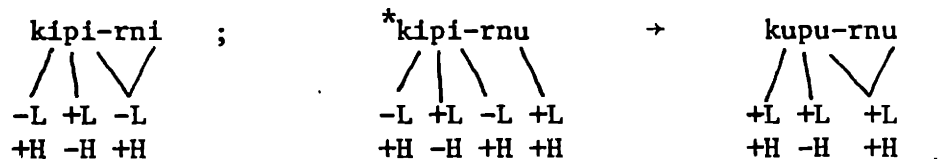

The harmonic deletion does not apply in kipi-rni since the morphological condition is not met. It does apply in kupu-rnu, unimpeded by the intervening [+L,-H]. Yet the rule as stated cannot apply in this manner -- it needs to be amended to conform with the observed kupu-rnu. Of course, an easy stipulation, but not revealing of the nature of the harmonies,

<sup>10</sup> The other V2 stems with this property are yipi-rni 'pick out -- as pimple', and yilyiwirрпи-rni 'slurp up (hot liquid)'. The alternant form kirрпи-rni of kipi-rni occurs in eastern Warlpiri. There are five V1 stems with this property, but they have not been observed in a harmony environment.

would be to specify that the segments to be autosegmentally represented for the purposes of the regressive harmony are just the class [+syll], omitting the [+labial] that are also represented for progressive harmony.

I suspect that a preferable solution lies in representing [labial] and [high] on separate autosegmental tiers, so that there are two autosegmental tiers, and the segmental tier. In this view, the problematic verb form just considered would have the derivation:

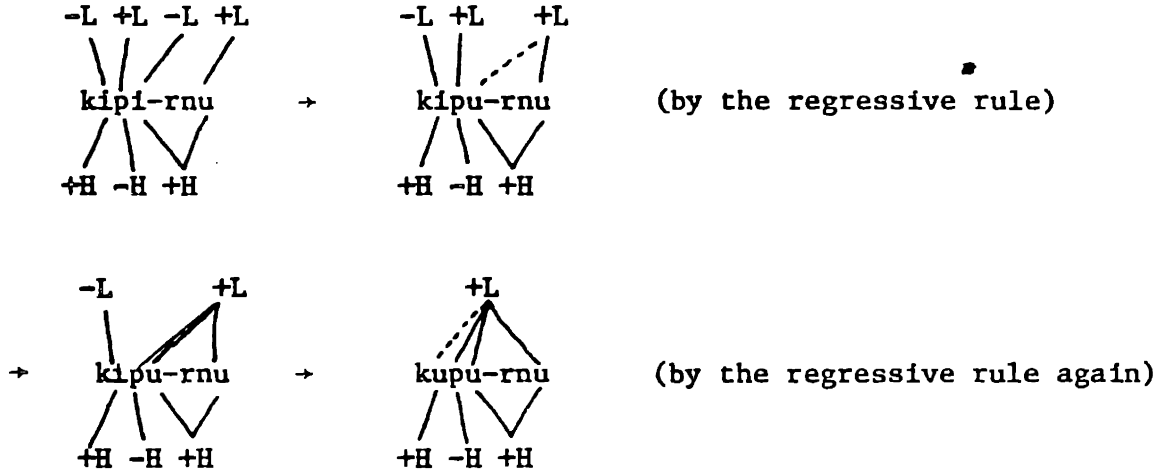

The statement of the harmonic deletion has accordingly to be changed, and the amended version of each is:

(i) regressive harmony (amended)

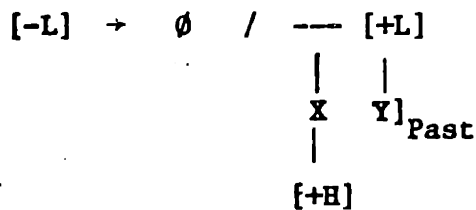

(ii) progressive harmony (amended)

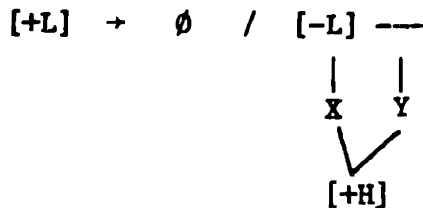

where X,Y are variables over segmental strings, possibly multiply attached to the given autosegments.

Now that there are two autosegmental tiers, the Obligatory Contour Principle requires reformulation. There are a number of ways to do this, and the following suggestion must be regarded as tentative, and subject to testing against similar processes in other languages. For instance, I state it solely in terms of the features L and H, relevant to Warlpiri vowel harmony, and this aspect, if no other, calls for generalisation.<sup>11</sup>

Obligatory Contour Principle (Warlpiri, amended)

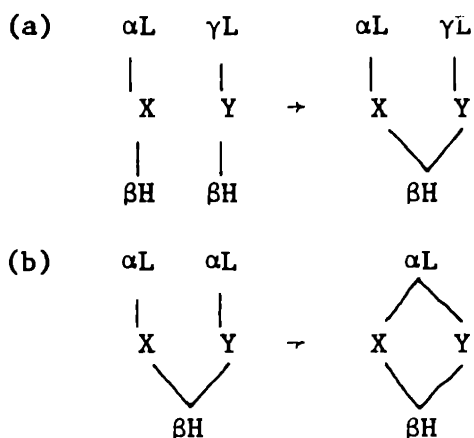

Applies throughout the course of a derivation.

(X,Y are variables over segmental strings)

To see the revised Obligatory Contour Principle at work, consider these two examples, one of each harmony type:

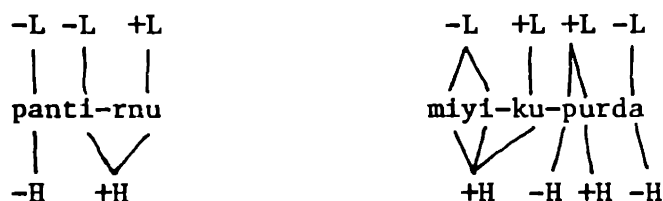

These underlying representations undergo the respective harmonic deletions and re-associations to give the following surface forms:



<sup>11</sup> For instance, we need to enquire whether the dominance of H over L observed in Warlpiri is perhaps characteristic of a L-harmony system, or perhaps predictable on other grounds. Investigation of the progressive H and B harmony of Nyangumarda (Hoard & O'Grady, 1976:64-67) and its interaction with palatal consonants may prove instructive; as may study of the H harmony of a → i in Djingilu (Chadwick, 1975).

Given the revised Obligatory Contour Principle, the two amended harmonic deletion rules provide an account of Warlpiri vowel harmony that is not only able to generate the required surface forms, but also goes a long way to explaining the cluster of properties summarised at the beginning of this subsection.

### 3.5.2 ALTERNATIVE "SYMMETRICAL" ACCOUNT

In this subsection I consider briefly an alternative approach to Warlpiri vowel harmony, and sketch the reasons for rejecting it in favour of the account of 3.5.1.

This alternative approach would subsume Warlpiri vowel harmony under the "symmetrical" type (cf. the "asymmetrical" type, of 3.5.1), and propose that the harmonising vowels are not underlyingly specified for labiality, only for height. It would recognise that a number of vowels are, on the other hand, underlyingly fully specified -- the vowels in the "neutral environments", as mentioned by Steriade, 1979:44-45 in the passage quoted in 3.5.1. The departure of this account from the one proposed in 3.5.1 is to assume that a, just like i and u, triggers (and, presumably vacuously, undergoes) a backness or labiality harmony applied to all three vowels, not just the two [+high] vowels.

Such an account of the progressive u → [i] assimilation could no doubt be made to work. It is reasonable to assign a to [+back], and thus find that nominal suffixes, and enclitics, surface in their u alternant when on a stem in a; e.g. minija-kurlu-rlu-lku-ju-lu etc. And the approach fits nicely with the following fact about vowel distribution in suffixes (brought to my attention by Paul Kiparsky). The suffixes and enclitics of Warlpiri whose first vowel is i are in the minority -- I list them here:

] $\langle N \rangle$ --- ] $\langle N \rangle$	<u>mipa</u> , <u>pink</u> <u>i</u> , <u>pinangi</u> (W)
] $\{+V, -N\}$ --- ]	<u>rni</u> , <u>yi</u>
] --- ]	<u>wiyi</u> , <u>yijala</u> , <u>kirli</u> , <u>ji</u> (H)
Auxiliary	<u>rli</u>

A number of them have an initial bilabial, which we know anyway blocks the progressive harmony. Two others, rni and rli undergo a special assimilation in some dialects (3.4(i1)). The remaining two, yijala and



kirli, are "pure enclitics" (2.7), and thus understandably "word-like" in their failure to harmonise; and in any case the initial palatal of y<sub>i</sub>, j<sub>i</sub> and y<sub>i</sub>j<sub>a</sub>l<sub>a</sub> may be relevant. Hence, the first, [+high] vowel of an affix would be underlyingly specified for backness in a few "pure enclitics", or else following the "blocking" bilabial consonants.

However, there are several reasons for dissatisfaction with the "symmetric" proposal. First, there is no explanation as to why an i does not cause assimilation across a bilabial, but a and u do, and that in the regressive harmony the bilabials do not "block" harmony at all. Second, in those dialects where the clitics r<sub>n</sub>i and r<sub>l</sub>i harmonise, there is no explanation of why their alternants in i appear after stems in a, whereas all other alternating affixes show the u alternant in such environments. Third, the triggering role of a does not extend to the harmony process in verbs, the regressive harmony:

kiji-ka,	<u>not</u>	*kuju-ka
throw-Imper		
wirnti-ja,	<u>not</u>	*wurntu-ja
dance-Past		

with the latter example, from the VI conjugation, also satisfying the morphological condition that the form be the Past tense. Fourth, the morpheme structure condition (3.2(5)) prohibiting

i [-labial] u

(either root internally underlyingly, or throughout a word's surface form, no matter of what lexical category) has no counterpart with a, e.g. a prohibition on ..iCa..; for there are numerous roots with all the other eight possible vowel sequences.

The regularities of the distribution of harmonising vowels can just as well be stated as morpheme structure conditions, which would have their counterparts anyway in statements about the distribution of unspecified vowels. Thus, there is no reason to prefer the "symmetrical" account, and a number of reasons for preferring the "asymmetrical" account of 3.5.1.

## 3.5.3 THE DOMAIN OF HARMONY

In the description of the vowel harmony facts in 3.5(1) and (ii), I observe that the domain of harmony does not always extend to the entire word, even though it normally includes all enclitics, and a cliticised Auxiliary.

The application of the harmony rules 3.5.1(i) and (ii) has to be limited to specified domains. I propose to define a harmony domain as follows:

A domain is a segmental string  $[X]$ , where X contains no  $[$ .

Thus the appropriate domains are defined directly from the morphological structure, using the brackets introduced by word-formation (see 2.2 - 2.3). The definition applies to give a maximal domain, i.e. a maximal string satisfying the given conditions.

Some of the examples from 3.5(1) and (ii) are repeated here to exemplify the given definition of domain:

[[[[minija]kurlu]rlu]lku]ju-lu  
 domain

[[pirri][kaju-rnu]]ju-lu  
 domain domain

[piki(piki)][[turnu][jarri-mi]]  
 domain domain domain

[[[yukiri][yukiri]]rli]  
 domain domain

[[miyi][kupu-rnu]]  
 domain domain

Notice that a harmony domain sometimes does not correspond to a morphological (sub)-constituent of the full word. There may be other ways to formulate the definition of domains, but any definition has to produce domains as

indicated in the above examples. It seems unlikely that an alternative theory of morphology would produce morphological structures which would have the indicated domains as sub-constituents in the case of inflected Nominals which are in turn compounds or reduplications. This is particularly so for the compounds and reduplications which are not at all productive, for the units corresponding to a harmony domain may not be a possible word, or may fail to have an assignable meaning (as in various frozen compounds and reduplications).

This definition of domain is utilised not only by the rules of vowel harmony, but also by another "prosodic" process, word stress. See 3.6.4.1 for examples.

### 3.6 STRESS

In this section I describe the range of stress patterns on Warlpiri words, and then account for the patterns with a small set of rules building metrical structure.

#### 3.6.1 BASIC STRESS PATTERNS

Previous study of Warlpiri stress is confined to the descriptive remarks of Hale, 1977:12-20, which, along with my own observations and further observations by Hale, provides the data used in this work.<sup>12</sup>

I know of no instrumental study of stress in Warlpiri, or indeed in any of its close genetic relatives. The impressionistic phonetic correlates of stress are (i) a relatively greater intensity on the stressed syllable, (ii) a relatively greater duration of the stressed syllable, and perhaps (iii) a somewhat raised pitch on the stressed syllable. Vowel quality is not much affected by stress or the lack of it. Intervocalic stop consonants show an allophony partly conditioned by the stress on the syllable containing the consonant -- "the voiced variety is slightly favored in syllables removed from the main stress. Thus a word like pakaka 'strike(Imperative)' is normally [pákaga]. Aspiration in stops is rare but sometimes occurs at the onset of an emphatically stressed initial syllable." (Hale, 1977:3).

The following generalisations hold about the surface distribution of stressed syllables:

<sup>12</sup> Jagst, 1975:41-44 also describes Warlpiri stress, and includes data consistent with that utilised in this account.

- (1) Primary stress is uniformly on the initial syllable of a word,<sup>13</sup> where a "word" includes any enclitics and a cliticised Auxiliary.

Certain non-initial syllables in words of four or more syllables may bear stress, not as prominent as the primary stress, but enough to make the syllable more prominent than its neighbour(s). Some patterns observed in the placement of these secondary stresses are:

- (2) (a) the last syllable of a word never bears a stress,  
 (b) the first syllable of a morpheme of two or more syllables always bears a stress,  
 (c) the second syllable of a morpheme never bears a stress,  
 (d) two stressed syllable rarely occur adjacent, and do so only when a monosyllabic Preverb is compounded with a Verb stem.

Secondary stress may also be observed on some monosyllabic morphemes, and on syllables of polysyllabic morphemes beyond the first and second. The stressed monosyllables have two sources. First, a morphologically definable class of monosyllabic morphemes appear to attract stress:

- (3) (a) monosyllabic Preverbs are always stressed, whether their vowel is short or long,  
 (b) monosyllabic Verb roots (eight in number) are always stressed, (though note that a Verb word always has at least two syllables and, through the special nature of verbal inflexion, would fall naturally under (2)(b) above, making (3)(b) redundant)  
 (c) any monosyllabic element beginning an Auxiliary (2.7.1) is stressed provided that the following element is monosyllabic.

---

<sup>13</sup> Reece's 1975 dictionary, quoted by Hyman, 1977:62 in his survey of stress, incorrectly ascribes penultimate word stress to Warlpiri. Reece gives only one example, viz. "ngalípa" 'we incl. pl.', which is in fact stressed normally, i.e. on the initial syllable, ngálipa. Reece's observation may be true of extremely slow and careful speech, as in dictation: [ŋá: lípa].

Another special pattern is recorded by Jagst, 1975:44 in his discussion of the exclamatory affix wu, which puts an intonation peak on the final syllable of the word to which it attaches. Jagst, 1975:41-44 otherwise records initial stress.

The study of intonation in Warlpiri is not pursued in this work.

Second, other secondary stresses are sometimes observed, on other monosyllables than covered in (3), and on non-initial syllables in polysyllabic morphemes. These secondary stresses are somewhat evanescent in comparison to those stresses described in (1), (2)(b), and (3), and are more apparent in slower speech, for instance. Their distribution is nevertheless governed by (2)(a),(c) and (d).

Note that I talk of the "syllables" of a morpheme, though strictly speaking syllables are units of the surface form of a word, rather than of a morpheme. However, since the morpheme structure constraints require every morpheme to have a vowel (3.2(1)), and there is a one-to-one correspondence between vowels (short or long) and syllables within the word, we can by extension give an unambiguous meaning to "syllables of a morpheme" in Warlpiri.

The dependence of stress placement on morpheme boundaries is well exemplified by the following "minimal pair" of segmentally identical words (from Hale, 1977:16):

[[yáparla] <sub>N</sub> ngùrlu] <sub>CASE</sub>	[[[yápa] <sub>N</sub> rlàngu] <sub>N</sub> rlu] <sub>ARG</sub>
FaMo -Erelative	person-e.g. - Ergative

On the other hand, the presence of consonant clusters, or "open" versus "closed" syllables, seems to make no difference to stress placement. Vowel length is probably relevant, but has low functional load in Warlpiri. Long vowels are confined to the first syllable of some Nominal and Preverb roots (3.2(1)), and it is hard to tell whether they affect stress. For instance, the difference between the pair:

ngúrrpa-ngku	ngúrrpa-rlu
throat-Erg	ignorant-Erg

may well involve an additional secondary stress in ngúrrpà-rlu, but it is difficult to control for the effects of the long vowel. The two exceptional roots, with non-initial long vowels, also suggest that long vowels are "bimoric", because of the perceived stress in the inflected forms:

yárdijlìnypa	yárdijlìnypà-rlu, yárdijlìnypà-ju
black ant sp.	-Erg                      -Top

(from Hale, 1966:683, Tape 2.18; stress transcription is mine),

pírilaali	pírilaali-rlì (?) .
ritual friend of initiate	-Erg

For regular examples of stress placement, consider the behaviour of the following Nominals under suffixation:

'man'	'tree'	'spinifex plain'	
wáti	wátiya	mánangkàrra	
wáti-ngka	wátiyà-rla	mánangkàrra-rla	(Loc)
wáti-ngkà-rlu	wátiya-rlà-rlu	mánangkàrra-rlà-rlu	(Loc-Erg).

The alternating character of the placement of certain secondary stresses shows up well in certain Auxiliary words. These sequences of monosyllabic elements lack any morphological structure on which to base the placement of stress (see 2.7.1):

[Wángka-mi] <sub>v</sub> ka.	'He's speaking'
kà-rna.	'I'm speaking'
kà-rna-ngku.	'I'm speaking to you'
kà-rna-ngkù-lu.	'We (Exclusive Plural) are speaking to you'
kà-rna-ngkù-lu-rla.	'We are speaking to you for it, etc.'

speak-NPast-Pres-I-you-pl.-Dat

### 3.6.2 METRICAL THEORY

I propose accounting for the Warlpiri stress patterns by adopting the metrical theory of stress. This theory is elaborated for English by Liberman & Prince, 1977, and has been applied successfully to problems in a number of languages. See Halle, 1979 and the works cited there, and Hayes, 1980.

The structures orchestrating the relative prominence of syllables are represented in metrical theory as binary-branching trees whose terminal nodes dominate syllables.<sup>14</sup> All nodes (except the "root" node) are labelled either "s"(strong) or "w"(weak) to encode the relative prominence of the node with respect to its sister node.

The metrical tree assigned to a complex word has three levels of organisation. The foot level has the syllables as terminal nodes. (Here I often symbolise a foot by "φ", and a syllable as "σ".) The feet are

<sup>14</sup> In more elaborated versions of the theory, metrical tree structure is extended "down" into the syllable, organising the segments which constitute it. This level of organisation does not intrude to a higher level in Warlpiri (pace the remarks near the end of 3.6.1), and is not discussed here.

are terminal nodes of the word level tree, which encompasses all non-compound words, including any enclitics and cliticised Auxiliary. Compound (and reduplicated) words may have more than one word level tree, joined together in larger word, or compound, tree.

The placement of stressed vs. non-stressed syllables is done by rules which place or build feet. In Warlpiri all feet are of the least-marked type, viz. left-branching, with left-daughters "s" and right-daughters "w". That is, Warlpiri feet have one of the following forms:

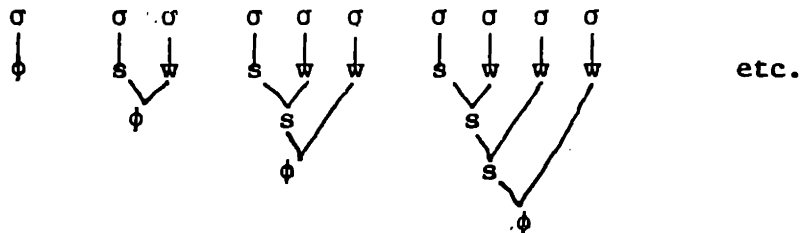

The first example of a foot, which does not branch, is called a "degenerate foot". Since the domain of foot-placement is basically the morpheme (in Warlpiri), and since there are rarely Warlpiri morphemes of five or more syllables, there are rarely examples subsumed under "etc." above.

### 3.6.3 RULES BUILDING METRICAL STRUCTURE

Rules are first presented which place feet within a word, and then further rules are presented which build and split feet, and join feet together in a word level metrical tree.

#### 3.6.3.1 FOOT PLACEMENT

The initial placement of feet occurs within morphemes, elements bounded in the notation of this work by hyphens, "-", as well as by the category brackets "[", "]".<sup>15</sup> The general rule is as follows:

- (4) (a) Place an unbounded left-branching foot on every polysyllabic morpheme
- (b) Place a degenerate (non-branching) foot on the following

<sup>15</sup> This distinction is relevant only with respect to the Auxiliary (the elements of which I separate by "-" but not "[", "]"), and to an extent simple Verb words, on which see commentary in 3.6.4.2.

morphemes:

- (i) a monosyllabic Verb root,
- (ii) the verbal inflexions (derivational affixes)  
       nja 'Infinitive' and nji 'Inceptive',
- (iii) a monosyllabic element beginning an Auxiliary.

Feet of four or more syllables produced by (4)(a) tend to undergo Fission -- rule (7) below -- into binary and ternary feet.

When applied to an inflected Verb, (4)(a) places a foot only on the root part and leaves out the inflexional morphemes. There are no<sup>16</sup> verbal inflexions of more than one syllable, in the morphological analysis of 2.5, so no inflexions receive feet by rule (4) other than the specified nja and nji.

The remaining stress rules use information provided in the feet placed by rule (4), and do not make use of morphological information.

The rule building additional feet within the domain of word level rules is:

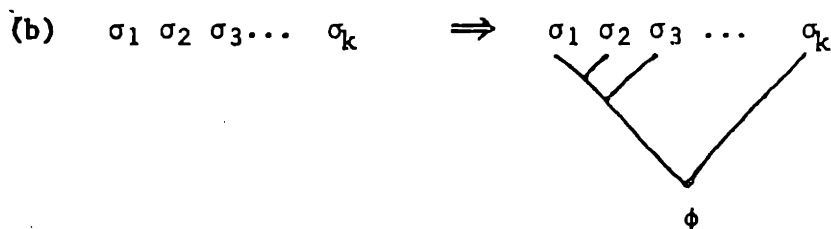
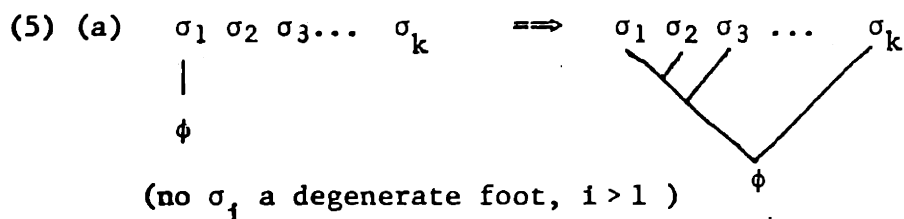

(  $k > 1$  ;  $\sigma_k$  may be in a degenerate foot )

In the application of (5)(b),  $\sigma_k$  may be a degenerate foot, as would appear from words in which a single unattached syllable occurs between a foot (on its left) and a degenerate foot (on its right) as in:

<sup>16</sup> In 2.5, the less common Present Presentational inflexion is given as disyllabic for V2-V5 roots. However, it may easily be analysed as having a morpheme boundary before the constant element nya.



watiya-rla-lpa(-jana)      (stick-Loc-Aux(-them))

(feet shown are from (4)). In such a situation, the unattached syllable rla, and the following degenerate foot, lpa, (which does not extend to a non-degenerate foot through operation of (5)(a) since it is not followed in turn by unattached syllables), go to form a binary foot. After the application of rule (5), the word has the following metrical structure:

watiya-rla-lpa(-jana)

Hence,  $\sigma_i$  can only be degenerate when  $i=k$ , the end of the maximal sequence of unattached or degenerate-footed syllables remaining after the application of (5)(a).

Both (5)(a) and (5)(b) apply maximally anywhere within a word that their structural description is met. However, they are disjunctively ordered, (a) before (b), in the sense that given a string of unattached syllables following a degenerate foot, (5)(a) applies, even though the structural description of (5)(b) is also met by the string of unattached syllables (without the degenerate foot). So in:

wangka-mi-ka-rna-ngku-lu-rla

the string rna-ngku-lu-rla maximally satisfies the structural description of (5)(b), but it is contained in the string ka-rna-ngku-lu-rla which maximally satisfies the structural description of (5)(a), and (5)(a) takes precedence. This ordering may be incorporated into the rule (5) by collapsing (a) and (b) with the parenthesis notation (which encodes the convention that the longer expansion applies before the shorter expansion):



wangka-mi-ka-rna-ngku-lu-rla

(speak-NPast-Pres-I-you-pl.-Dat)



These Feet which dominate four or more syllables undergo rule (7):

(7) Foot fission

Optional (according to tempo of speech -- more frequent in slower speech); may apply to own output

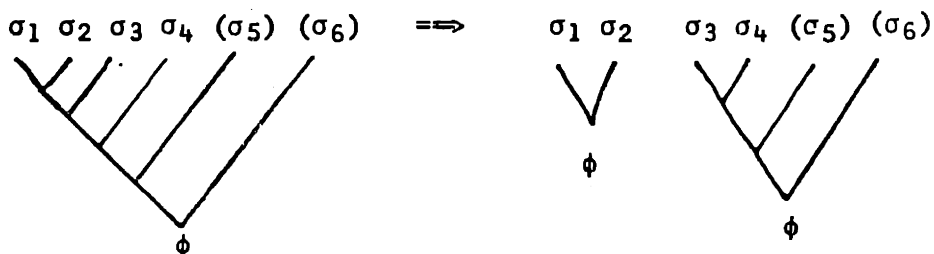

Compare Liberman & Prince, 1977:296-97, "Foot Formation" rule.

### 3.6.3.2 WORD LEVEL METRICAL STRUCTURE

Whatever feet the word contains after application of rules (4)-(7) are grouped into the word level metrical tree:

(8) Group feet into a left-branching word tree.

The word-tree in Warlpiri is taken to be left-branching in the formulation of (8), rather than right-branching, on rather slim evidence. The most direct evidence for the direction of branching of a word-tree is the relative prominence among the non-primary stresses, but in Warlpiri this a matter of fine judgement and there may well not be consistency in the assignment of the relative (non-primary) prominences that have been detected in the pronunciation of various instances of words with two or more secondary stresses. However, in cases where I have felt able to detect such differences in prominence, the last secondary stress has seemed stronger than ones preceding it. Such an observation points to a left-branching word-tree.

Certain complex words in Warlpiri contain in their metrical

structure more than one word-tree: compound and reduplicated Nominals, and Proverb-Verb combinations. Such complex words have a word-tree on each prosodic domain of which they are composed, and the domains are identical to those defined morphologically in 3.5.3 for vowel harmony. A word-tree is assigned to each domain in the complex word, and these word-trees are in turn combined, by (8)(b):

(8)(b) Group word-trees into left branching compound word-trees.

The evidence for the separate compound level is clearest in the stress pattern of reduplications (and, potentially, compounds) of units of four (or, potentially more than four) syllables. Thus the three levels relative stress in the following example are reasonably clear:

[ [ngáti-nyânu][ngàti-nyânu] ]

(See 4.3 for further discussion.)

The entire tree is labelled according to:

(9) Left-daughter is s, right-daughter is w.

Equivalently, the labelling rule may be presented as: "Right node is s iff it branches". A terminal node of the compound tree is thus taken to be non-branching, and a terminal node of the word tree taken to be non-branching whether or not it dominates a branching foot, and similarly a terminal node of the foot tree taken to be non-branching whether or not it dominates a branching syllable node (or rime). The choice between these, or other, labelling principles is to be made on universal grounds, which are the subject of current research, see for instance Hayes, 1980. In any case, the labelling achieved by (9) will no doubt be readily provided in any amended version of the theory.

#### 3.6.4 EXAMPLES

The exemplifying nominals of 3.6.1 are here assigned metrical structure according to the rules presented in 3.6.3. These examples do not involve any degenerate feet, which will come in later examples.

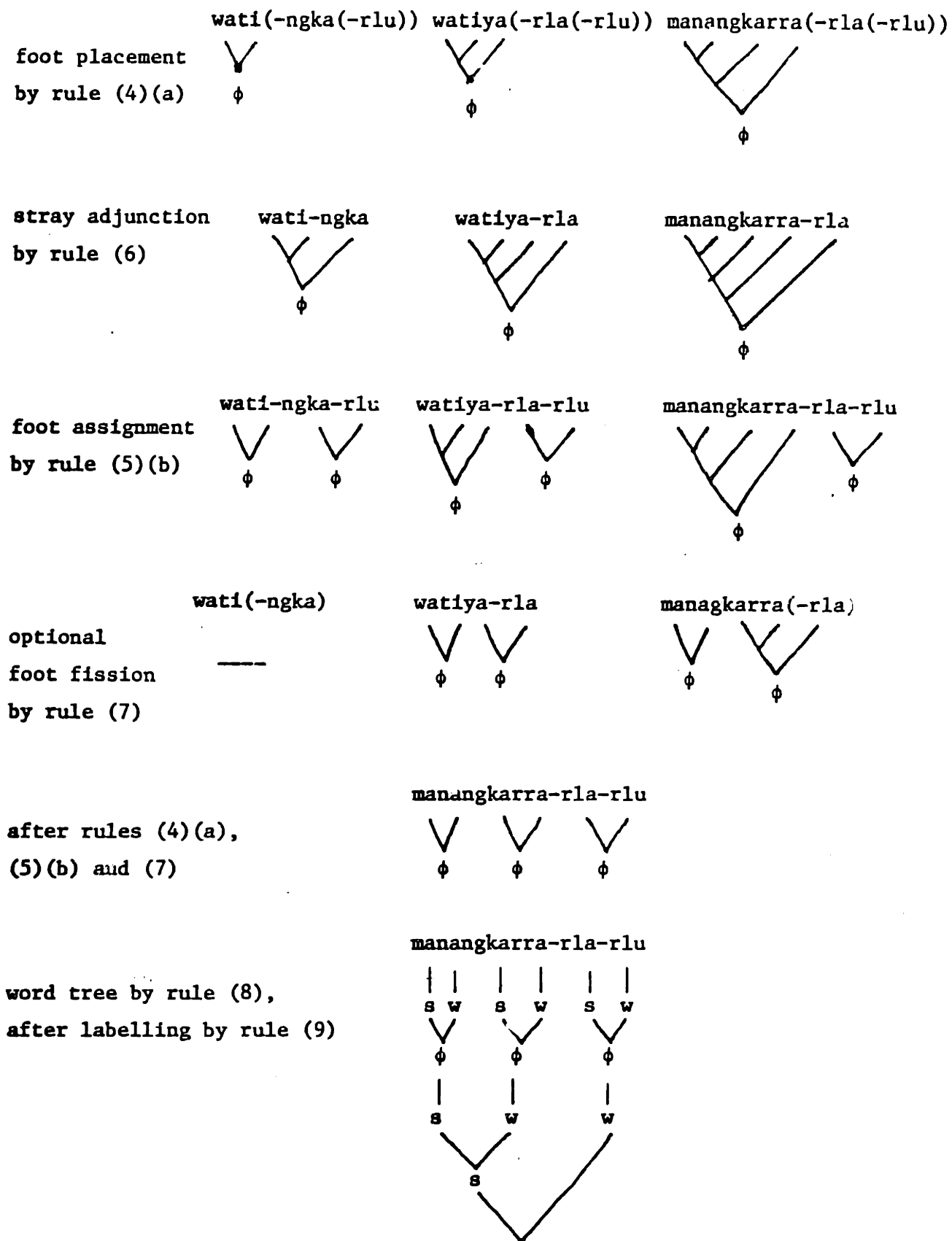

A syllable dominated only by "s" nodes is the primary stress. Other syllables immediately dominated by an "s" receive secondary stress. Syllables immediately dominated by "w" are unstressed.

A degenerate foot on the first element of an Auxiliary is partly exemplified in watiya-ria-lpa(-jana) in 3.6.2. A parallel pattern is found on the same Auxiliary cliticised to a four-syllabled inflected Verb:

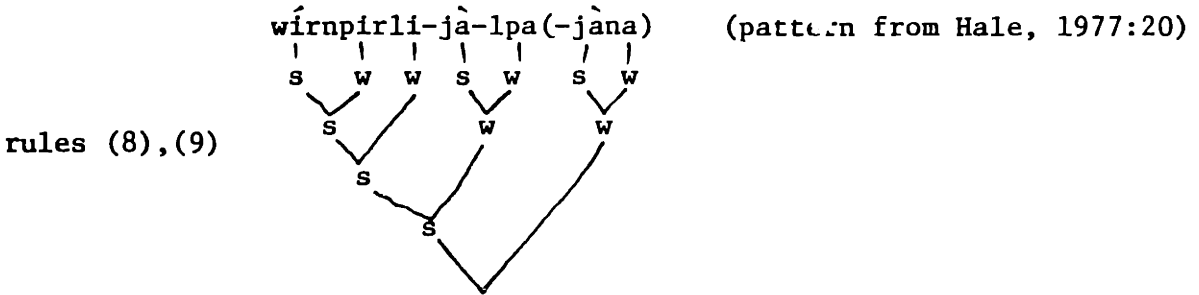
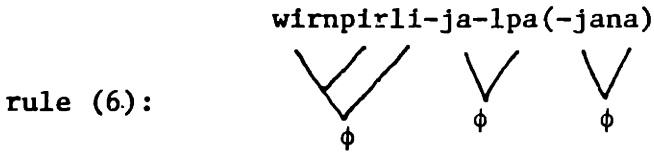
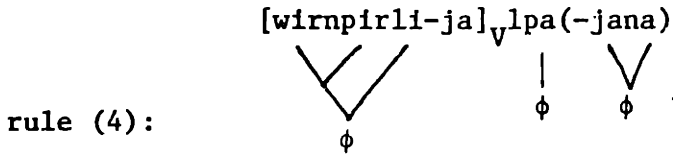

3.6.4.1 COMPOUND LEVEL STRESS

In a word with more than one prosodic domain, rule (8)(b) (3.6.3) applies to group together the word trees on the separate domains. An example of a word with two domains (cf. 3.5.3) is:

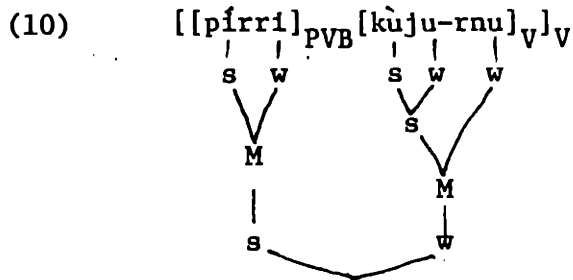

where I have indicated each word level tree by "M" (sc. mot, cf. Liberman & Prince, 1977:260), and rule (8)(b) has joined the two word level trees together.

Similarly, a word with three domains is:

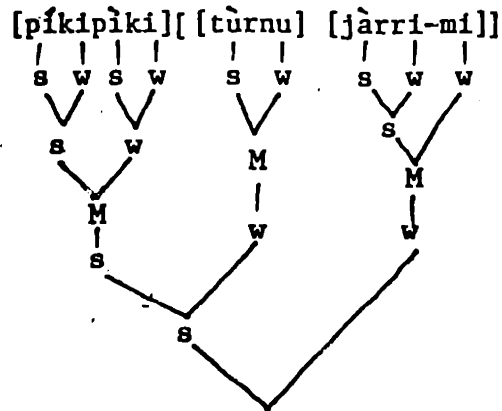

This structure predicts that the primary stress falls on the first syllable (as it in fact does). As to the most prominent secondary stress, this structure makes no immediate prediction, since the relative prominences assigned by the structure dictate only a partial, not a total ordering among the stressed syllables. Additional principles have to be prescribed (perhaps varying from language to language) as how the secondary stresses are to be compared in general. (See Liberman & Prince, 1977:259 for one possibility, for English.) Whether such an additional principle is justified in Warlpiri is at the moment an open question, as the requisite data on the relative prominence of secondary stresses is not readily available. One observation might be made at this stage however: the stress pattern on a Preverb-Verb combination appears to be maintained, but subordinated, when an additional Preverb precedes the combination (as in the above example). Now, the combination tũrnu-jãrri-mi contains the syllable tu more prominent than ja; so this relationship may well be maintained even when pikipiki precedes, and the most prominent secondary stress in the structure shown above may well be on the syllable tu. This observation is quite tentative, however, and I pursue the matter no further.

Another interesting situation may arise with a monosyllabic Preverb. When such a Preverb combines with a Verb, there are two prosodic domains, and the first domain contains just one syllable:



[tũrɪ]	<sub>PVB</sub>	[pãrdi-mi]	<sub>V</sub>	'open -- as of eye'		
[wĩly]	<sub>PVB</sub>	[pãka-rni]	<sub>V</sub>	'beat severely'		
[tũrɪ]	<sub>PVB</sub>	[tũrɪ]	<sub>PVB</sub>	[pãji-rni]	<sub>V</sub>	'split by cutting'





CONJ	NON-PAST	INFINITIVE	INIFINITIVE-SEQ COMP
V1	wángka-mi wírnpirli-mi	wángka-nja wírnpirli-nja	wángka-njà-rla wírnpirli-njà-rla
V3	pí-nyi	pí-nja	pí-nja-rla
V2	páka-rni wálapàrri-rni	páka-rni-nja wálapàrri-rni-nja	páka-rni-njà-rla wálapàrri-rni-njà-rla
V4	ngá-rni	ngá-rni-nja	ngá-rni-njà-rla
V5	yá-ni	yá-ni-nja	yá-ni-njà-rla
CONJ	INCEP-NPAST	INCEP-INFINITIVE	INCEP-INFIN-SEQ COMP
V1	wángka-nji-ni wírnpirli-nji-ni	wángka-nji-ni-nja wírnpirli-nji-ni-nja	wángka-nji-ni-njà-rla wírnpirli-nji-ni-njà-rla
V3	pí-nja-ni pí-nja-nji-ni	pí-nja-ni-nja pí-nja-nji-ni-nja	pí-nja-ni-njà-rla pí-nja-nji-ni-njà-rla
V2	páka-rni-nji-ni wálapàrri-rni-nji-ni	páka-rni-nji-ni-nja wálapàrri-rni-nji-ni-nja	páka-rni-nji-ni-njà-rla wálapàrri-rni-nji-ni-njà-rla
V4	ngá-rni-nji-ni	ngá-rni-nji-ni-nja	ngá-rni-nji-ni-njà-rla
V5	yá-ni-nji-ni	yá-ni-nji-ni-nja	yá-ni-nji-ni-njà-rla

Given the specification that the Infinitive nja and Inceptive nji bear a degenerate foot (rule (4)(b)(ii)), the proposed rules assign the observed stress in almost all the given forms. For example, the correct stress is assigned in:

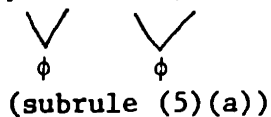
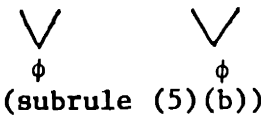
rule (4)	<p>paka-rni-nja(-kurra)</p> 	<p>paka-rni-nja-rla</p> 
rule (5)	<p>paka-rni-nja</p>  <p>(subrule (5)(a))</p>	<p>paka-rni-nja-rla</p>  <p>(subrule (5)(b))</p>

rule (6)

\_\_\_\_\_

paka-rni-nja-rla

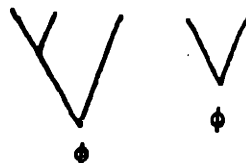

rules (8),

(9)

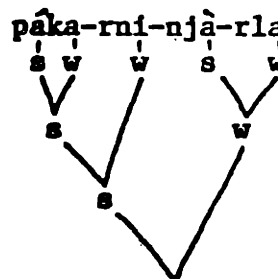
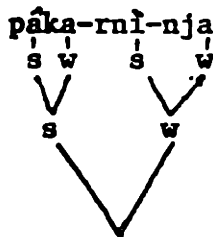

Note that if a degenerate foot were not assigned to nja, the rules would assign the pattern \*paka-rni-nja-rla.

The rules fail to assign the observed stress on certain combinations of the Infinitive and Inceptive with the four monosyllabic verb roots of the V3 conjugation, viz. pi-nyi, yi-nyi, ka-nyi, and nya-nyi, represented by pi-nyi in the above table. Consider the derivation the rules would provide for the Inceptive-NonPast:

rule (4)(b)

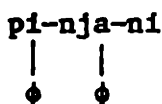

cf.

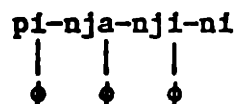

rule (5)(a)

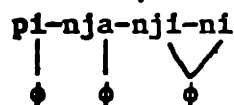
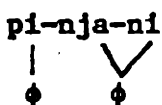

rule (8),(9)

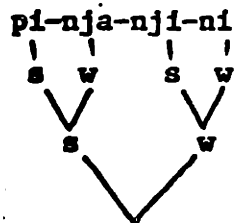
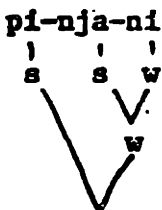

Thus, the form \*pi-nja-ni is predicted, whereas pi-nja-ni is observed. Similarly, \*pi-nja-ni-nja-rla is predicted instead of pi-nja-ni-nja-rla. An expedient rule to remedy this is the following<sup>17</sup>:

<sup>17</sup>There is only one other situation where there could conceivably be two adjacent degenerate feet (within the one prosodic domain — cf. monosyllabic Preverbs, 3.6.3.1). This would occur if an Auxiliary beginning with a monosyllabic element were to cliticise to an Infinitive used as a Preverb. However, this particular construction has not been observed and may in fact be ungrammatical — see the discussion in 2.6.2.

$$(12) \quad \begin{array}{ccc} [\sigma & \sigma & \Rightarrow \\ | & | & \\ \phi & \phi & \\ \cdot & & \end{array} \quad \begin{array}{c} [\sigma \\ \swarrow \searrow \\ \phi \end{array}$$

The "fix-up rule" (12) would have to apply before rule (5). An alternative is to write its effect as a condition on rule (4)(b)(11).

In any case, the four roots affected do exhibit special behaviour with the nja and nji affixes which in itself calls for lexical specification (see 2.5). The Inceptives of just these four roots may have theme vowel a, whereas all Inceptive stems have theme vowel i (as can be seen in the table). Additionally, just these Inceptives take an Imperative suffix that is not the usual one on a V5 stem, (viz. they take nka, Irrealis -nka-rla, instead of -nta, -nta-rla.) (Hale, 1974:15). Finally, they have the alternative Inceptive form pi-nja-nji-ni etc., not available for any other roots, which has a regular stress pattern, as derived above.

### 3.6.5 REMAINING PROBLEMS

In all, the rules of 3.6.3 account for the variety of stress placement in a fairly natural manner.

The apparently exceptional behaviour of V3 roots with the Inceptive and Infinitive inflexions is discussed in 3.6.4.2.

One rule in need of further study is (7), Foot Fission, the formulation of which will most likely prove to be over-simplified here. The conditions under which it applies, at least, need to be investigated.

Another aspect of the account of 3.6.3 in need of refinement has to do with the extent to which an enclitic sequence is part of the host word. For instance, the following word is assigned the given structure by the rules of 3.6.3:

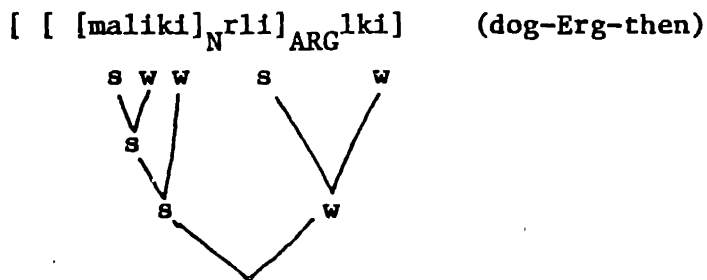

with predicted pattern málik-i-rlí-lki. But its observed pattern does not always conform to this pattern. When a secondary stress is detectable on

such words, it is as likely to be málikì-rli-lki, and perhaps preferably.<sup>16</sup>  
It is as if the word málikì-rli is assigned its stress pattern without taking account of the enclitic lki. Further, when a further enclitic follows, or a monosyllabic Auxiliary element, the enclitic lki may attract the stress, as in:

? málikì-rli-lkì-ka  
dog-Ergative-then-Pres

The proposed rules predict the pattern ?málikì-rli-lki-ka, and I am unable to say which pattern is the more accurate prediction. By specifying that the initial element of an Auxiliary always is assigned a foot (if polysyllabic, by virtue of 4(a); if monosyllabic, by the specification 4(b)(iii)) I have effectively provided a metrical juncture of sorts at the beginning of a cliticised Auxiliary. There are indications that the possibility of such a juncture may extend to all word-enclitic boundaries.

It is not uncommon for a Warlpiri word to have the form of a "reduplication". That is, the word has the form:

- [ X Y Z ], where X,Y,Z are strings of segments, and
- (a) X = Y (possibly Z =  $\emptyset$ ), written X<sup>2</sup>-Z,  
 or (b) Y = Z, written X-Y<sup>2</sup>.

The use of a superscript "2" to indicate reduplications is a practice confined to this chapter, and is not part of the Warlpiri practical orthography. Furthermore, the hyphen "-" adjacent to a reduplicated string is not necessarily a morpheme boundary, as indicated by "-" elsewhere in this work.

I call X,Y,Z in this formula, "reduplication partials". In Warlpiri, the two reduplicated partials are normally (pace 4.1.2) identical at the segmental level, and differ only in degree of stress and possibly through the operation of rules of phonetic detail.

Defined so generally, Warlpiri reduplication is not a unified phenomenon. Reduplicated forms occur as Nominals, Preverbs, Verbs, and even in a couple of suffixes. Some of the reduplicated Nominals and Preverbs have no counterpart form which is "unreduplicated" (i.e., of the form XZ or XY in terms of the above formula), and some words that do have an unreduplicated form lack a close or regular semantic relationship to it (that could be associated with the reduplication process). Finally, there is variation in the length of the reduplication partial -- it is usually two syllables, but may be one syllable, or a whole morpheme, however long.

But there are regular reduplication processes as well:

- (i) reduplication of an entire Nominal root (and some stems) as a stem-forming process
- (ii) reduplication of the first foot of a verbal word subsequent to word-level metrical and harmony rules.

There is a third type, favoured by younger speakers, which is also quite regular;

- (iii) reduplication (or repetition?) of an entire Verb.

These are discussed in 4.2-4.4. First, I present the range of the

irregular, lexical, nominal reduplications, and show certain sub-regularities of form and meaning, which are of particular interest historically.

#### 4.1 LEXICAL NOMINAL REDUPLICATION

Consider the following pairs of words;

- |      |                         |   |
|------|-------------------------|---|
| (1)  | ngalikirri              | 'grinding stone -- the upper one'             |
|      | ngalikirri <sup>2</sup> | 'kneecap, patella'                            |
| (2)  | ngapurlu                | 'breast, milk'                                |
|      | ngapurlu <sup>2</sup>   | 'multi-barbed spear'                          |
| (3)  | ramarra                 | '1. rib; 2. edge'                             |
|      | ramarra <sup>2</sup>    | 'beside, along the edges of, along the sides' |
| (4)  | wanta                   | '1. sun; 2. hot weather, summer'              |
|      | wanta <sup>2</sup>      | 'brown ant'                                   |
| (5)  | Japangardi              | '(male subsection term)'                      |
|      | japangardi <sup>2</sup> | 'cricket sp.'                                 |
| (6)  | kurdiji                 | '1. shield; 2. circumcision initiation'       |
|      | kurdiji <sup>2</sup>    | 'shoulder blade'                              |
| (7)  | pirilyi                 | 'charcoal'                                    |
|      | pirilyi <sup>2</sup>    | '1. black beetle sp.; 2. pupil of eye'        |
| (8)  | Jungarrayi              | '(male subsection term)'                      |
|      | jungarrayi <sup>2</sup> | 'native tobacco spp.'                         |
| (9)  | yaka                    | 'louse'                                       |
|      | yaka <sup>2</sup>       | 'sensitive, sore -- as spot on body'          |
| (10) | jarnpa                  | 'kurdaitcha (magical hairy man type)'         |
|      | jarnpa <sup>2</sup>     | 'moth stage of edible grub sp.'               |
| (11) | rdaka                   | '1, hand, fingers; 2. forefoot'               |
|      | rdaka <sup>2</sup>      | 'sign language, "finger talk"'                |

Although in each case it is possible to perceive a connexion between the meanings of the pair, there is by no means a general rule, and the reduplicated form has taken on a life of its own (speaking historically) and requires a separate lexical entry. Consistent with this, we find reduplicated forms with no recorded unreduplicated counterpart:

- |                     |                    |
|---------------------|--------------------|
| wirnp <sup>2</sup>  | 'long and slender' |
| kurlpu <sup>2</sup> | 'stingy'           |

kuntu <sup>2</sup>	'1. fat, in good shape; 2. heavily foliated; 3. country abounds in food'
kalya <sup>2</sup>	'wife's brother, sister's husband'
ngarli <sup>2</sup>	'on the side, on its side'
kiti <sup>2</sup>	'armpit'
layi <sup>2</sup>	'1. greying hair; 2. fleecy cloud; 3. dry leaves on tree'
lalji <sup>2</sup>	'raging, on the rampage'
kumpa <sup>2</sup>	'froth on running water, foam on running water or standing water'
miya <sup>2</sup>	'wichetty grub'
rduku <sup>2</sup>	'chest (bone)'
japarla <sup>2</sup>	'...'
paki <sup>2</sup>	'trimming blade of native adze'
ngunju <sup>2</sup>	'white clay -- used for mourning'

Further there are forms that must have existed as reduplications prior to the historical stage of augmentation (of consonant-final stems) with \*pa (see 2.6.5, 3.2), but have not been recorded unreduplicated:

mirrirn <sup>2</sup> -pa	'mirage'
manjarn <sup>2</sup> -pa	'irritation -- as smoke in eyes'
martiny <sup>2</sup> -pa	'dangerous lightning'
kipirr <sup>2</sup> -pa	'outside of the stomach'
pujarr <sup>2</sup> -pa	'marsupial mole'
piirr <sup>2</sup> -pa	'half white, brown and white -- as colour of whistling eagle ( <u>kirrkaranji</u> )'
pararr <sup>2</sup> -pa	'mode of progression in stalking whereby some concealing object is constantly kept between the stalker and his quarry'

Included in this type are reduplications with partials consisting of a single mora:

miny <sup>2</sup> -pa	'wet, damp'
pin <sup>2</sup> -pa	'thin and flat'
ngurn <sup>2</sup> -pa	'small marsupial sp.'
ngurr <sup>2</sup> -pa (L)	'pig' (presumably of recent, imitative, origin).

Further, there are forms that may historically be compounds, with one element being a reduplication. These are all of the form X-Y<sup>2</sup>, where X may be a related word, but Y apparently never is:

yarda-manya <sup>2</sup>	'bindi-eyes (plant sp.)' (cf. manya 'soft')
karli-ngardu <sup>2</sup>	'collarbone' (cf. karli 'boomerang')
kuna-puju <sup>2</sup>	'backwards in motion or thrust' (cf. kuna '1. excrement; 2. anus; 3. guts')
kuna-murru <sup>2</sup>	
warra-karlu <sup>2</sup>	'Solanum petrophilum'
yalyapa-kira <sup>2</sup>	'lung'
karrkala-payi <sup>2</sup>	'insect gall on coolibah tree'
pirti-rawu <sup>2</sup>	'long winter's night'
purda-ngala <sup>2</sup>	'straggling behind, bringing up the rear' (cf. purdangirli 'behind, in the rear')
wangka-nyarli <sup>2</sup>	'excessive talk, loud and boisterous talk' (cf. wangka-mi 'to speak')
milpa	'runny juice' (cf. ngapa 'water, rain', milpa 'eye, raindrop', pata-karri-mi 'to fall')
-pata <sup>2</sup>	
ngapa	
kiri-wuru <sup>2</sup>	'dust hanging in air' (also kiyi-wuru <sup>2</sup> )
ngirnti-wulu <sup>2</sup>	'smoke sent up from signalling fire in bush'
ngapa-kurru <sup>2</sup>	'naughty (of child)' (=miinjinpa)
ngalyarrpa	'sandhill country' (cf. all three bases, each of which mean 'sandhill') <sup>1</sup>
yilyampuru	
-marra <sup>2</sup>	
jilja	(Hale, 1966:84)
jinta-marri <sup>2</sup>	
parra-jingi <sup>2</sup>	'all day' (cf. parra 'sun', jingi <sup>2</sup> 'throughout')
ngapurlu-punngu <sup>2</sup>	'multi-barbed spear' (cf. (2) above)
nyiya-kanti <sup>2</sup>	'things, items in material culture'
nyiya-rnirri <sup>2</sup>	'wood borer sp.' (cf. nyiya 'what')

Furthermore, there are reduplicated forms which resist analysis as historical compounds (some above), since they involve a partial consisting of a single syllable with a short vowel, otherwise found only in some reduplicated forms of the type X<sup>2</sup>-pa, exemplified above:

<sup>1</sup> The partial marra turns up in jinta-ku-marra-rni (one-Dat-marra-hither ?), now a frozen expression 'all, everyone', and jarrku-marra (separately-) 'equal', though there may be no relationship between these forms.



jákurdukùrdu	'novice taken on journey'
míjilijìli	'navel'
kíwinyiwìnyi	'mosquitoes'
púyukuyùku	'mist, fog; haze'
yúmarimàri	'smooth knob-tailed gecko'
lungkardakarda	'hot westerly wind'
kalpardaparda	'night bird sp.'
língirringìrrji	'jaw, jaw bone'
kurdarrirdarri	'ahead, before others'

It is convenient to recognize a boundary of sorts in such forms since the stress rule of foot-assignment (3.6.3) respects the boundary between the two partials, and thus the surface stress on these words is as indicated. (An alternate stress pattern for some of the words of this surface type is considered in 4.1.2.)

In sum, the variety of forms found in nominal reduplication all fall under one of the following shapes:

$X^2$	where X is a word of two or more syllables
$X^2$ -pa	where X has the form $CVC^2VC$ , or, in a few examples, $X=CVC$
$X - Y^2$	where X is mostly a disyllable (but can be a monosyllable or a trisyllable), and Y is always a disyllable

Note that there are no reduplicated forms of shape  $X^2 - Y$  among Nominals or Preverbs, (although there are Preverbs of this shape may be as the result of the verbal reduplication to be considered below).

#### 4.1.1 SEMANTICS OF NOMINAL REDUPLICATION

Lexically reduplicated Nominals fall into several loose semantic groups, for which I now list examples.

##### (1) Bird names, with various degree of imitativeness

kirlil <sup>2</sup> -pa	'galah'
kuurr <sup>2</sup> -pa	'boobook owl'
jintirr <sup>2</sup> -pa	'willie-wagtail'
paku <sup>2</sup>	'bellbird'
pinta <sup>2</sup>	'1. butterfly, moth; 2. aeroplane'

purla <sup>2</sup>	'fork-tailed kite, hawk sp.'
tiyi <sup>2</sup> , tiya <sup>2</sup>	'mudlark, magpie lark, Grallina sp.'
mani-rtirrpi <sup>2</sup>	'mulga bird'
kuluru <sup>2</sup>	'diamond dove, Geopelia cuneata' (also kurlukuku)
yinka-rdaku <sup>2</sup>	'owlet nightjar'
wiiny <sup>2</sup> -pa	'grey falcon'

This pattern has extended to the term for the introduced domestic fowl, possibly borrowed from Australian English "chook":

juku <sup>2</sup>	'chicken'
-------------------	-----------

There are other bird names that seem to be imitative of the call, but do not involve reduplication as clearly, e.g. kakalyalya 'white cockatoo', suggesting that "repetition" rather than reduplication is as much behind these forms.

(2) Properties which distribute to parts of a whole

yutu <sup>2</sup> , wutu <sup>2</sup>	'bent over, stooped'
tarlku <sup>2</sup>	'crooked'
paka <sup>2</sup>	'dry and flaking -- as of skin, foot'
malja-rlawu <sup>2</sup>	'branchy, many limbed, many forked -- of tree'
warnta <sup>2</sup>	'1. across, athwart; 2. crossed pieces of wood etc.'
nyurltu <sup>2</sup>	'matted, tangled -- of hair'
kulkurru <sup>(2)</sup>	'in the middle, midway'
minkarra <sup>2</sup>	'square, resolved -- of dispute' (cf. kuja 'thus', jarra 'Dual', minkarra 'even')
[kuja-jarra] <sup>2</sup>	
ranku <sup>2</sup>	'skinny'
kuruwarri <sup>2</sup>	'variegated' (cf. kuruwarri '1. mark, design; 2. spirit essence')
pimpalypari <sup>2</sup>	'covered with knicks, blemishes' (cf. pimpalypari 'knicked')
karaly <sup>2</sup> -pa	'smooth' (cf. karalya 'smooth')
jirlpari <sup>2</sup>	'spotty, flecked -- as native cat'
nyirnti <sup>2</sup>	'rough -- as file; ripply -- as water'
julpurnpari <sup>2</sup>	'serrated, notched'
kulpurrpari <sup>2</sup>	'crumpled, squashed (e.g. billy can)'
mawurlpari <sup>(2)</sup>	'flaked'

palyanji <sup>2</sup>	'covered with sticky substance' (cf. palya 'wax -- from spinifex (used as glue)')
nyuturr <sup>2</sup> -pa	'curly -- of hair'

and these terms referring to circularity:

mirli-ngirri <sup>2</sup>	'1. circular, round, ring-shaped; 2. bark water container; 3. innertube'
wirri-ripi <sup>2</sup>	'spinning dizzily -- of ground'
warri-kirdi <sup>2</sup>	'around, in a complete circle or revolution'
warri-ngirnti <sup>2</sup>	'around in a circle'

(these last three being productive Preverbs, 2.6.4).

(3) Derivation by attenuation or resemblance, "ish"

(i) Colour terms

Root	Root Meaning	Reduplication Meaning
yalyu	1. blood; 2. large blood vessels	red
yurlpa	red ochre	red
yukiri	green, alive -- of plants	green
wajirrki	green grass	green
karntawarra	yellow ochre	yellow
yarringki	blue -- as of sky	blue
walya	ground, earth, dirt, sand	1. brown; 2. death adder (colour of earth)
yulyurdu	smoke	grey, light purple
kunjuru	smoke	grey
maru	black	blackish
*tiri	tirinji 'begging' tiri-pardu 'joey'	red

and note additionally terms with no attested unreduplicated counterpart:

piirr <sup>2</sup> -pa	} 'half white, brown and white -- etc.'
puwun <sup>2</sup> -pa	
puun <sup>2</sup> -pa	
puyurr <sup>2</sup> -pa	
	'brown -- of plumage, fur, skin'
	'grey, smoky colour -- as cat' (cf. Western

Desert puyu 'smoke'; Warlpiri puyukuyuku 'fog')

## (ii) Other terms of attenuation or resemblance

<u>Root</u>	<u>Root Meaning</u>	<u>Reduplication Meaning</u>
wirlki	1.cheek, side of face; 2.hooked boomerang;3. curve	crooked, bent
yulyurru	cold weather, winter	early winter
mungalyurru	morning, around sunrise	predawn
jalangu	now, today	nowadays
nguku (L)	water	spit out water like spray, or into hand

and note this pair:

ngaka	'soon, a short time in the future; by-and-by'
ngakarra <sup>2</sup>	'some indefinite time in the future'

and these terms with no attested unreduplicated counterpart:

turn <sup>2</sup> -pa	'incipient breasts'
punju-ngiyi <sup>2</sup>	'incipient beard'
[rangkarr-kurlu] <sup>2</sup>	'between midnight and sunrise'
	(cf. [rangkarr] <sub>PVB</sub> [ka-nyi] <sub>V</sub> 'to pre-dawn')

## 4.1.2 NEAR REDUPLICATIONS

There are some forms which may be reduplications, but are not strictly so according to the definition given at the beginning of the chapter, in that the reduplicated partials are not identical on the surface. These "near"-reduplications include some which have an unexpected stress pattern, or which alternate with "true" reduplicated forms, in a manner suggesting that they have an underlying representation which is a true reduplication, not just a "near" one. The examples include:

wárunḡarungka	'1. out of one's head, drunk; 2. varanus gilleni (lizard sp.)' (cf. warungka '1. deaf, insane; 2. heedless, forgetful')
yúlyurd(uy)ùlyurdu	'grey, light purple' (cf. yulyurdu 'smoke')
wájirrk(íw)àjirrkí	'green' (cf. wajirrkí 'green grass')
wárnápàrnápa	'hairy-tails, Trichinium sp.'

mfjilljili	}	'navel'	(Hale, 1966:622)
mfjilijili			
ngályurrályurru		'small red-breasted finch sp.'	
mályurrályurru			
yáwulàwulu		'yam sp.'	
nályurrályurru	}	'whip snake'	
yálypinjàlypinji			
yárringki(iy)àrringki		'blue'	

If these words are taken as reduplications of the form  $X-Y^2$ , which some of them could be, then the wrong stress pattern would be assigned. For example, wa-rungka<sup>2</sup> would be stressed \*wárunkarũngka. Further, there would be a large proportional increase in the number of forms of the shape  $X-Y^2$  where X is a monosyllable -- mostly in such forms, X is polysyllabic. Finally, for some the connexion with an obviously related unreduplicated form would be obscured. Indeed, there would be a puzzle as to why warungka, say, does not intensify by reduplication, to give warungka<sup>2</sup>. At least for the optional variants included in the above list, there is justification here for a minor deletion rule, lexically governed to be sure, which would relate the short and long forms.

This optional reduction rule is clearly conditioned by morphological and metrical structure. It applies only to underlying forms of the shape  $X^2$  where X is a trisyllable, a property encoded into the following rule by requiring that the deleting vowel be outside of the binary feet lexically assigned in every (polysyllabic) morpheme. Thus, the rule may only apply before any word-level metrical structure is built, even before feet are built across morpheme boundaries or are formed by stray-syllable adjunction. (See 3.6 for details of the stress rules assumed.)

(12) Syllable Reduction

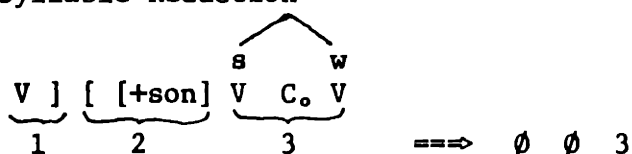

Condition: Term 1 is in a stray syllable.

Sensitive to a lexical diacritical feature.

The rule (12) applies as follows to wajirrki<sup>2</sup> 'green':

Input: \ [wajirrki][wajirrki]

Rule (12):

∅

Output: wajirrka*j*irrki

Surface form: wajirrka*j*irrki

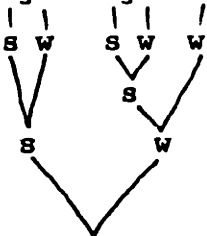

Can this rule of Syllable Reduction be extended to the forms which are "near" reduplications, but show no alternation with a full reduplication? In particular, should it extend to the nasal-initial "near" reduplications in the above list? The evidence is that such extensions are probably unjustified. All the clear instances of the rule apply to forms with an initial semivowel (y or w), and there are a number of reduplicated forms with an initial consonant other than y or w which do not undergo the rule though they satisfy its structural description:

ramarra-ramarra	'along the edges of, etc.'
ngapurlu-ngapurlu	'multi-barbed spear'
marluri-marluri	'several separate claypans'

Hence, it is reasonable to add to Rule (12) the requirement that Term 2 be not just [+son], but rather [-syll,-cons,-back], i.e. {y,w}. The remaining "near"-reduplications are thus treated as lexical entries in their own right, reanalysed perhaps from an historical reduplicated source. In fact, forms such as mjilijili are further evidence of this reanalysis, bringing the stress pattern into conformity with that of the CV-X<sup>2</sup> type, mentioned earlier in 5.1. Another example of this shift comes in:

yɔlyurrpulyɔrrpu	'cold weather, winter' (cf. yulyurrpu 'winter')
------------------	---

which, unlike most of this type, has an unreduplicated counterpart.

Syllable Reduction, amended to apply only to delete Vy and Vw, has

only one exception that has come to my attention. This is:

yukiri-yukiri 'green' (cf. yukiri 'green, alive -- of plants')

which, if it were to undergo Syllable Reduction, would produce the form \*yukirukiri. Notice that this violates the prohibition on i[-labial]u sequences (3.2(5), and its word-level generalisation). If anything, the output would be \*yukirikiri, but this has not yet been observed.

A productive rule similar to Syllable Reduction applies to combinations with the structure:

[Infinitive]<sub>PVB</sub>[ya-ni]<sub>V</sub> (see 2.6.2)

Forms of this type preferably delete the initial y of the Verb, as in:

pf-nja-(y)à-ni	'going hitting'
páka-rnĭ-nja-(y)à-ni	'going hitting' (see 2.6.2 example)
wfrrnpirli-nja-(y)à-ni	'going whistling' .

The differences between this and Syllable Reduction are (a) this deletion applies directly after a binary foot, unlike Syllable Reduction; (b) just the y is deleted in most instances, and a trace of the preceding vowel is normally retained, to give a long vowel [a:] even perhaps with the stress on the beginning of the long vowel. Actually, there may be an example of this less vigorous deletion in:

wákirid[à:]kirdi 'the highest reaches of tree, branches'  
(cf. wakirdi '1. joey; 2. tip of tail, wing')

Indeed, the application of Syllable Reduction may generally merge into this latter y-deletion. The differences just mentioned are quite speculative, and further investigation could well reveal more variability than encoded into Rule (12) above.

Finally, mention might here be made of a "near" reduplication which is even less amenable to a "reduction" derivation:

yirnkirnkiri 'loose, weak -- as chair with seat loose,  
woomera with loose hook' .

If a root \*yirnkiri were postulated, Syllable Reduction would give at best \*yirnkirirnkiri, and there is no process to elide the secondarily-stressed ri to obtain the required form. This word, then, is akin to kakalyalya in that it involves repetition, not reduplication.

## 4.1.3 MORPHEME STRUCTURE CONDITIONS

Nominal and Preverb reduplication must be taken into account in the checking of morphemes by certain of the morpheme structure conditions (3.2). Of course, this is quite consistent with nominal reduplication being a lexical process of stem-formation, albeit with irregular aspects.

There are three constraints which apparently apply "prior" to reduplication:

- (1) Long vowels occur only in the first syllable of a word (3.2 (1)).

All but one exceptions to the condition (1) as stated above are reduplications, e.g.

kuurrkuurpa	'boobook owl'
wiinywiinpa	'grey falcon'

including reduplicated monosyllabic Preverbs (as we will see below):

maarr <sup>2</sup> -ma-ni	'blink'
juurl <sup>2</sup> -pi-nyi	'hop, buck'

- (2) A morpheme contains no sequence iCu, unless C is p or w (3.2 (5)).

This constraint is satisfied by entire words after the operation of the vowel assimilation processes (3.4-3.5), and is satisfied by the underlying form of every morpheme as well, other than recent borrowings.

Exceptions to this condition as stated are found across the boundary between reduplication partials, as in:

yukiri-yukiri	'green'
yunpayi-yunpayi	'Calocephalus patycephalus (plant sp.)'
kurdiji-kurdiji	'shoulder blade'
kuruwarri-kuruwarri	'variegated'

- (3) There are about six reduplicated forms which exhibit a partial with initial ly, which otherwise occurs morpheme-initially only in one or two words (see 3.2 (2)). In pílyirriyirri at least, it is apparent that the stress placement is sensitive to the boundary between reduplication partials, otherwise \*pílyirriyirri would result. The preferable synchronic analysis probably does not assign these words internal morpheme boundaries, and the lexical redundancy rule of foot placement (3.6.3) is over-ruled where necessary -- perhaps, optionally -- by specific



lexical marking of foot on these words.

There are two apparently reduplicated forms which might be mentioned here, which are the sole reduplicated forms whose partials do not conform to the morpheme structure condition on root (non-suffixal/enclitic) morphemes, that they cannot begin with a consonant cluster (3.2 (1)):

jarntarrurrtarru-ya-ni	'to shuffle along on one's knees' (cf. jarntarru 'kneeling')
jalanjurrunjurru (jala-njurru <sup>2</sup> )	'person who teases and incites another to fight and is shameless about it' (Hale, 1966:18)

Finally, there are a couple of nominal suffixes which occur in reduplicated form:

(1) wana<sup>2</sup> 'along, because of, through' (see 2.3.2 (iv))

This is related to the case suffix wana 'Perlative, along, because of, through' and there is apparently (in this sense) no difference in meaning between the two affixes. An example:

Karnta-wana<sup>2</sup>-ju ka-lu-jana      jirrama-nya pi-nyi?  
woman-Perl -Top Pres-333-333    two-Quest    hit-NPast  
'Will they hit two [men] because of the woman?'

Ngapa-wana<sup>2</sup>-pala ya-nta.  
water-Perl-22      go-Imper  
'You two go through the water.'

(Both examples from Hale's transcription of a dialogue: Wangkami kapalanyanu, 1976:10.)

However, wanawana has an additional meaning not shared by wana, viz. 'inexchange for'; compare the semantic effect of reduplications of 4.1.1 (2) above.

(ii) kangu<sup>2</sup> 'having (plurally/distributively)' (2.3.1.1)

This may be etymologically related to the verb ka-nyi 'carry', which has Nomic kangu 'carrier' (attested in compounds). Examples include:

Ngurrju ka-lu      nyina partari-kangu<sup>2</sup>.  
good      Pres-333    sit    blonde-having  
'They are nice, blonde ones.' (op. cit., p.3)

## 4.2 REGULAR [+N] REDUPLICATION

The type of nominal reduplication with the most regularity is that which forms plurals and distributives of certain Nominals, and Infinitives.

There is reason to distinguish two types of plural nominal reduplication: (i) reduplication of most nominal roots with human reference to form a plural; (ii) reduplication of nominal stems to form a plural with distributive sense in a clause with other expressions of the distributivity. The former is less predictable, probably best seen as a process of intermediate productivity which is still basically lexical, as the examples show.

(i) The nouns which form a plural by reduplication (copying the entire root) are primarily those with human reference:

kurdu	'child'
wati	'man'
karnta	'woman'
kamina	'girl, maiden'
wirriya	'boy'
purlka	'old man'
muturna	'old woman, mother (initiated man speaking)'
yaparranji <sup>2</sup>	'children' (cf. yaparranji '1. child, children; 2. toes')
rduju	'woman'
mardukuja	'woman -- after onset of menstruation; female'
marliyarra	'advanced initiate, man admitted to advanced initiation'
wurlkumanu	'old woman' (borrowed from English)

However, there are at least two terms in this domain (ngarrka 'man', yapa) which do not reduplicate: nor do subsection or simple kin terms reduplicate their roots. (Complex kin terms may reduplicate to form a plural -- see Laughren, forthcoming.)

Other plurals formed by reduplication are the following animates:

(13)	yakalpa	'emu chick'
	yakalpa <sup>2</sup>	'emu chicks'
(14)	kiwinyi	'mosquito'
	kíwinyiwinyi	'swarm of mosquitoes'

(15)	murruru	'hornet'
	murruru <sup>2</sup>	
	murrururruru	'swarm of hornets'

Curiously, most disyllabic loans from English in this domain occur in reduplicated form. Thus:

jipi	}	'sheep'
jipi <sup>2</sup>		
yipijipiji		'fish'
juku <sup>2</sup>		'fowl'
piki <sup>2</sup>		'pig'

Also, these topographic terms reduplicate to give plurality:

(16)	yaturlu	'rock, boulder'
	yaturlu <sup>2</sup>	'rocky country'
(17)	rdaku	'1. hole in the ground; 2. deep; 3. flesh wound resembling a hole'
	[rdaku-kari] <sup>2</sup>	'bad holes in the ground, bumpy'
(18)	rdupulpari	'prominent hillock in otherwise level or nearly level country'
	rdupulpari <sup>2</sup>	'undulating, hilly country'
(19)	marluri	'claypan'
	marluri <sup>2</sup>	'several separate claypans on a single plain'

and see 4.1.1 (2).

At least two adjectival nominals reduplicate to form a plural:

wita	'small'
wir <sup>1</sup>	'big'

The plural is taken to refer to humans or animates in the absence of other indications, such as are present in:

Kapi-rna rdilyki<sup>2</sup>-paka-rni wita<sup>2</sup>-karda-lku pirli yali-ji.

Fut-I break -NPast small-into-then stone that-Top

'I'll break that stone into small pieces.' (Hale, 1966:359)

Further evidence that even the pluralising nominal reduplication is lexical may be adduced from the behavior of nominal suffixes.

First, reduplication is always of a stem, and never includes an inflexional affix, when the form is a Nominal (this is to be contrasted with the situation for verbs described in 4.4). In fact, the few cases where a reduplication partial may be analysed morphologically all involve affixation of restricted nature, e.g. the formative pari or kurlu in [rangkarr-kurlu]<sup>2</sup> (which normally does not follow a consonant).

Second, the nominal suffixes which exhibit allomorphy dependent on the syllabicity of the stem to which they are affixed are sensitive to the additional syllables added by reduplication. Hence, the Ergative suffix ngku ~ rlu generally takes the velar allomorph after a disyllabic stem, and the lateral allomorph after a stem of three or more syllables (2.3.4). Consider then the alternation in:

kurdu-ngku  
child-Erg

kurdu<sup>2</sup>-rlu (\*kurdu<sup>2</sup>-ngku)  
children-Erg

This is just as for compounds — e.g., from 2.4.2,:

[kuna]<sub>N</sub>ngku            [[mulyu]<sub>N</sub>[kuna]<sub>N</sub>]<sub>N</sub>rlu

(ii) The second, most productive, nominal reduplication type forms distributive plurals.

The clearest examples of nominals reduplicated in this way are reduplicated stems of kin-terms, as in:

- (20) [Ngati-nyanu]<sup>2</sup>-rlu ka-lu-jana kuruwarri kiji-rni kamina<sup>2</sup>-ku  
mother-Poss -Erg Pres-333-333 design throw-NPast girl - Dat

Yalikarangu-rla.

(place name)-Loc

'The mothers are putting the designs on the girls at  
Yalikarangu.' (Junga Yini 1.4,12)

- (21) ...kuja-rna-lu-jana nya-ngu [kirda-nyanu]<sup>2</sup> nganimpa-rlu.  
Rel-111-333 see-Past father-Poss we ex.pl.-Erg  
'...we saw our fathers' (Big Willie-Japanangka, text)

- (22) [Kirda-nyanu]<sup>2</sup>-rlu kala-lu-nganpa wankaru-rlu-wiyi, yujuku  
father-Poss-Erg -333-111 alive-Erg-first shelter

ngurrju-ma-nu tarnnga-ngku.

make-Past long time-Erg

'Our fathers when they were alive used to make shelters for us.'

(ibid.)

Note that a term such as ngati-nyanu means 'X's mother' (cf. ngati-na 'my mother'), and that when reduplicated as in (20) above, ngatinyanu<sup>2</sup> means 'their mothers', and cannot be used to mean 'his, her mothers' -- i.e. the distributivity introduced by reduplication extends to the possessor of the kinsman. (Note that the idea 'his mothers' is quite reasonable in Warlpiri culture.)

Other clear examples involve the nominal derivational suffix kari 'other, another; one of a pair' (2.3.1.1), as in (17) above, and also in:

jirrama-kari-jinta	'three' (cf. jirrama 'two', jinta 'one')
[jirrama-kari] <sup>2</sup>	'four'
panukari <sup>2</sup>	'mob by mob' (cf. panu 'many')

- (23) Wari-[ya-ni-nja]<sup>2</sup>-ku [rdaku-kari]<sup>2</sup> wita puju-pinyi.  
 climb-go-Inf -Purp holes small footholds-hit-NPast  
 'He'll put small holes for footholds for climbing [down into a native well].'

(iii) This last example also shows a Infinitive, [+V,+N], also reduplicating to give a spatial distributive. Further examples follow:

- (24) ...yangka [ya-ni-nja]<sup>2</sup>-karra-rlu, warlalja-rlu ngula  
 that go-Inf -Prox-Erg self,own-Erg that  
 ka-rna-lu-nyanu yama nya-nyi [ya-ni-nja]<sup>2</sup>-kurra.  
 Pres-III-Ref1 shade see-NPast go- Inf -Obv  
 '...as we go along, we see our own shadow going along.'

(Hale, 1966:445)

- (25) [Wapa-nja-ngu]<sup>2</sup>-rna wirliya-ju wanka-ju pardi-ja, yi-ka-rna  
 walk-Inf-Result-I foot-Top raw-Rop rise-Past Causal-Pres-I  
 warrarda wapa-mi wanta wiri-ngka.  
 always walk-NPast day big-Loc

'From walking around a lot, my feet get raw, since I walk  
around all day long.' (Hale:Mick Connell, untaped, p.5) 134

(26) Kala pama-jangka -- yungu-lpa-rnalu warrarda nga-rnu --  
but beer-Result Causal-Imperf-111 always drink-Past  
kala yungu-rna warungka-jarri-ja -- pama [nga-rninja-ngu]<sup>2</sup>.  
but Causal-I heedless-Inch-Past beer eat-Inf-Result  
'But because of beer -- which we were always drinking --  
but when I went mad -- it was from drinking beer' (ibid.)  
This sentence also was recorded with [nga-rninja-rla]<sup>2</sup>.

(27) [Wangka-nja-rla]<sup>2</sup> ka-rna-ju jurru paji-ni.  
speak-Inf-Seq Pres-I-Refl head cut-NPast  
'While I was talking, I cut my head.' (ibid., (78))

(28) [Wapa-nja-rla]<sup>2</sup>-rna, mata-jarri-ja-rna kulkurru.  
walk-Inf-Prox-I tired-Inch-Past-I midway  
'While walking along, I got tired midway.' (ibid., (83))

In general, the form and meaning of (lexical and productive) reduplicated Nominals is comparable structurally to that of N-N compounds, in the following respects. They are not formed by productive rules in the main, though there are some sub-regularities; their reference is not entirely predictable from the meaning of the component nominals; and one nevertheless needs to recognize a morpheme boundary between the component nominals, if only for the morpheme structure conditions, and stress placement.

#### 4.3 STRESS ON NOMINAL REDUPLICATIONS

The stress pattern of a reduplication of four syllables is clearly one where the most prominent secondary stress is that on the first syllable of the second occurrence of the reduplication partial. For example, in (20) above, the stress pattern is clearly:

ngátinyânu-ngàtinyânu-rlu

(where a circumflex indicates a stress subordinate to that marked by the grave accent).

This pattern indicates a metrical structure:

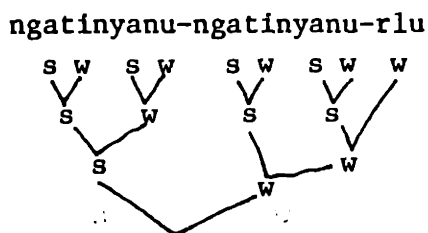

which will result from the stress rules proposed (3.6.6.1) because the rules building the word-level tree must operate on two separate domains. Each left-bracket [ begins a domain, as in:

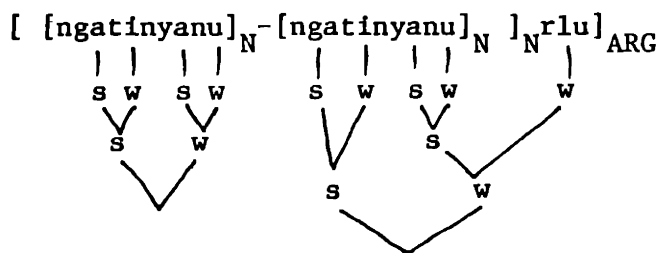

If there were a simple application of the general stress rules to an input such as (29), for the stress (30) would be predicted, wrongly.

(29) ngatinyanu-ngatinyanu-rlu

(30) \*ngátinyânu-ngâtinyânu-rlu

Similarly, the one known four-syllabled root which reduplicates has the following stress predicted:

kárntawârra-kárntawârra 'yellow' (Hale, 1966:683 and elsewhere)

The infinitivally based reduplications, as in 4.2 (iii), also show double-word-tree stress, e.g.

wâpanjângu-wâpanjângu (from (25))

and one even shows the operation of Rule (12) above, giving:

yâninj(ay)âninjâku (from (23))

There is one more fact to do with stress which may be mentioned, which illustrates the lexical nature of initial stress-foot assignment, and has to do with reduplication. Certain reduplicated forms have more than one possible stress pattern (usually a Warlpiri word, apart from

stress reduction, has only one possible pattern), e.g.:

yínka-rdàku-rdàku	'owlet nightjar'	(usual pattern)
~ yínkardakùrdaku	(observed once by Hale, in speech of Mick Connell Jupurrula)	

This may be influenced by some consideration of folk-etymology, or analogical restressing along the lines of the míjilijìli ~ míjilìjìli pair (4.1.2) -- I mention it in the interests of completeness.

#### 4.4 REGULAR VERBAL REDUPLICATION

Verbs in Warlpiri may be reduplicated by a rule with the effect of (31):

$$(31) \quad \underset{1}{V} [ \underset{2}{C} \underset{0}{V} \underset{2}{C} \underset{0}{V} (C) X ] \Rightarrow 1 \ 2 \ 2 \ 3$$

"Copy the first two syllables (or the first syllable, if it has a long vowel) of a verb to the left"

I shall discuss the semantic effect of applying this rule later -- it generally involves an added speed, vigour, or distributivity. First I shall illustrate the operation of the rule on the form of verbal words, and then discuss its interaction with other rules of Warlpiri.

#### FORM OF RULE

The following examples show the first two syllables being copied, with verbs of varying syllabicity:

- (32) Kurlarda-lu muku-yirra<sup>2</sup>-ka -- kapanku<sup>2</sup>-rlu-lu yirra-ka --  
 spear - 222 all-put-Imp                      quickly-Erg-222 put-Imper  
 wawirri-li    panti-ka.  
 kangaroo-222 spear-Imper

'Quickly ready the spear, you all -- spear the 'roo. '

(Hale, 1959:561-2)

- (33) Milpa-ngku    ka-ngalpa yarli<sup>2</sup>-ni.  
 raindrops-Erg Pres-122    wet-NPast

'Raindrops are wetting us. '

(Hale, 1959:721)



- (34) Marna ka-lu karri<sup>2</sup>.  
 grass Pres-333 stand  
 'Clumps of grass are standing around.' (Hale, 1959:737)
- (35) Mangkurdu ka-lu parnka<sup>2</sup>-mi-rra.  
 cloud Pres-333 run-NPast-forth  
 'Many clouds are scudding along.' (Hale, 1959:722)
- (36) Lulju ka-lu [yurrampi-rli] kiji<sup>2</sup>-rni-nja-parnka.  
 dirt Pres-333 ant sp.-Erg throw -Inf-run(NPast)  
 'They (honey ants) run back and forth dumping their clods of dirt.' (Hale, 1959:774)
- (37) Pirlu ka parnta<sup>2</sup>-rri-nja-mpa ya-ni.  
 hill Pres crouch -Inf-across go-NPast  
 'The mountain extends in a series of humps.' (Hale, 1959:798)  
 Cf. parntarri-mi 'crouch'
- (38) Mururru-lu ngarla<sup>2</sup>-rri-ya.  
 mirth-222 laugh -Imp  
 'Laugh (you pl.)!' (Hale, 1959:734)  
 Cf. ngarlarri-mi 'laugh'
- (39) Wirnpi<sup>2</sup>-rli-mi  
 whistle -NPast
- (40) Pungka-pungka!  
 'Hit it quickly!'  
 Cf. pu-ngka 'hit it'  
 hit-Imp

These show that no matter whether the verb root has two syllables (32)-(36), three syllables (37)-(39) or one syllable (40), the reduplication rule applies to the first two syllables of the verbal word. This applies also when the first two syllables of the complete verbal word are in the Preverb -- as in (36), (37) -- but not if the Preverb is one of the class of "productive" Preverbs (2.6.4.1), as is the case with muku in (32), which are apparently less closely bound to the verb. It is hard to

tell in some instances whether a reduplicated disyllabic Preverb is the result of this productive verbal reduplication, or a lexically reduplicated Preverb of the sort considered together with nominal reduplication in 4.1. See examples already given, and also:

- |                                 |                        |
|---------------------------------|------------------------|
| jaa-mala <sup>2</sup> -karri-mi | 'to yawn'              |
| ngaanykutukutu-jarri-mi         | 'to get out of breath' |

These often have no unreduplicated counterpart, and do not have the semantic property of verbal reduplication. Note that these never involve a verb root, only a Preverb. They are not of the type being discussed in this section.

No verb root has a long vowel, but some monosyllabic Preverbs do, and they reduplicate according to the rule (31) as well:

- |                                 |   |
|---------------------------------|---|
| (41) maarr-ma-ni                | '1. flash -- of lightning; 2. wink -- of eye' |
| maarr <sup>2</sup> -ma-ni       | '1. blink -- of eye; 2. twinkle -- of star'   |
| (42) wuurr-(w)angka-mi          | 'to whirr'                                    |
| wuurr <sup>2</sup> -(w)angka-mi | 'to howl -- of the wind'                      |
| (43) jaa-karri-mi               | 'to be agape'                                 |
| jaa <sup>2</sup> -karri-mi      | (do.)   |

These examples also show a syllable-final consonant being captured by the reduplication rule -- the consonant (C) optionally present in the structural description of (31). This occurs also in:

- |                                       |                          |
|---------------------------------------|--------------------------|
| (44) puturr <sup>2</sup> -pa-jarri-mi | 'to break out in a rash' |
|                                       | (Hale, 1966:724)         |

--although this may be better classified along with nominals in pa, as in 4.1, particularly since jarri-mi productively combines with Nominals to form Inchoatives (2.6.1). A better example may be:

- |                               |   |
|-------------------------------|---|
| (45) jamparl-pi-nyi           | 'to chew it'  |
| jamparl <sup>2</sup> -nga-rni | 'to chew vigorously -- as in eating something hard' |
| (cf. nga-rni 'to eat')        |   |
| (46) jukurr-ma-ni             | 'to dream of it'                                    |

jukurr-jukurrpa-ma-ni                    'to dream of it'  
 jukurrpa-ma-ni                            'to dream of it'

Compare examples where a final C is not copied (and (56) with monosyllabic Preverb):

jika-jakarr-wapa-mi                    'walk, squeaking feet'  
 jiji-jijily-wapa-mi                    'walk on tiptoe'  
 narnti-narntin-wapa-mi                'walk stooped over'

(Hale, 1959b:20)

In reviewing the above examples, it is apparent that the rule of reduplication makes use of the same unit that the stress does -- the first foot of the word. So we can re-state (31) as:

(47) VERBAL REDUPLICATION

$$\begin{array}{c} \phi \\ | \\ \vee [ X \ Y \quad \Rightarrow \quad 1 \ 2 \ 2 \ 3 \quad \text{where } \phi \text{ is a foot.} \\ 1 \ 2 \ 3 \end{array}$$

This applies before the word-level tree is built (and it is built regularly -- left-branching). It could also apply after the word-tree is built (in which case it is minimally amended to incorporate the extra foot). Notice that the "first foot" of a verb with monosyllabic root is taken to be the binary foot including the inflexion -- as in (40) above, whereas a disyllabic root combines with the inflexion to make up a ternary foot, but only the binary part copies, as in (33):

yarli-ni

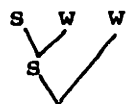

yarli-yarli-ni

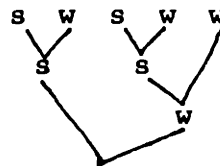

In other words, the rule (47) appears to use binary feet constructed by the first foot-building Rule (which attaches a syllable not in a foot to an immediately preceding degenerate foot), but not ternary feet built by stray-syllable adjunction (see stress section 3.6.3).

The clearest empirical difference between (31) and the revised version (47) is that they produce different outputs when applied to a

monosyllabic preverb with a short vowel. Such preverbs are not common.

Examples are :

- |      |               |                                |
|------|---------------|--------------------------------|
| (48) | tirl-pardi-mi | 'open -- as of eye'            |
|      | tirl-paka-rni | 'split it open -- as with axe' |
|      | tirl-pi-nyi   | 'split it down the middle'     |
| (49) | wily-paka-rni |                                |
|      | wily-pi-nyi   | 'beat severely'                |

Now, as it is formulated, rule (31) would apply to such verbs and produce reduplicated forms like:

- |      |                     |                              |
|------|---------------------|------------------------------|
| (50) | *tirlpatirlpardi-mi |                              |
|      | *tirlpitirlpi-nyi   | (cf. tirlpi-mi 'chip,flake') |
|      | *wilypawilypaka-rni |                              |

whereas (47), since such preverbs are assigned a degenerate foot lexically (as part of stress assignment), would predict:

- |      |                    |
|------|--------------------|
| (51) | tirl-tirl-pardi-mi |
|      | tirl-tirl-pi-nyi   |
|      | wily-wily-paka-rni |

These outputs, (51), are not attested, but there are indications that they have a much better chance of being well-formed than those of (50). First, there are reduplicated preverbs on the pattern of (51), but without unreduplicated counterpart:

- |      |                              |   |
|------|------------------------------|---|
| (52) | winywiny-ma-ni               | 'to whistle under one's breath' (cf. winywinypa 'grey falcon')                |
|      | wirr <sup>2</sup> -karri-mi  | 'to shiver'   |
|      | mil <sup>2</sup> -pi-nyi     | 'to shake (spear set in woomera) to test feel and balance'                    |
|      | turl-turl-paju-rnu           | 'split by cutting' ( <u>Winywinypakurlu</u> , page 5, 1978)                   |
|      | lurlurl-pi-nyi               | 'to shake it out'   |
|      | muly <sup>2</sup> -karrka-mi | 'to leave impressions in the ground while walking' (cf. mulypari 'footprint') |

And in the closely related Warlmanpa language I have recorded such pairs as:

- |      |                      |                        |
|------|----------------------|------------------------|
| (53) | warlk-wanganya       |                        |
|      | warlk-warlk-wanganya | 'bark -- as dog'       |
| (54) | putt-jiya-ka         | 'burn it'              |
|      | putt-pu-ngka         | 'send, hunt away'      |
|      | puttputt-nga-nyja    | 'boil (it), flush out' |

as well as other examples of reduplicated short-vowelled monosyllables paralleling (54), but not forms like (50). (Nash, 1979b).

Of course, if forms such as (51) are produced by the rule (47), then the stress pattern of the output should show two adjacent degenerate feet -- and indeed this may be observed with [túr1-tùr1-pàjurnu] as in (52). But most of the frozen examples in (52) do not clearly exhibit this pattern (difficult to distinguish anyway with consonant-final syllables), and instead exhibit a binary foot on the two syllables of the reduplicated preverb.

#### 4.4.1 PROPERTIES PECULIAR TO V REDUPLICATION

Let us now contrast the operation of verbal reduplication with the properties of nominal reduplication, 4.1-4.3.

We have already seen -- in (40) -- that verbal reduplication may copy an inflexional suffix. Given the way the rule operates, this can only happen when the rule is applied to a monosyllabic verb root, of which Warlpiri has seven (spread among three conjugations). Another example is in (63) below.

Furthermore, verbal reduplication follows the regressive vowel harmony of i triggered by a Past-tense suffix's u, as described in 3.5. This assimilation rule accounts for the alternations such as:

kiji-rni	}	vs.	kuju-rnu
throw-NPast			throw-Past
kiji-ka			
throw-Imper			

Such regressive assimilation does not normally proceed through an intervening low vowel a, so:

yirra-rni	,	yirra-ka	,	yirra-rnu
put-NPast		put-Imper		put-Past

The only instances where it appears to penetrate a syllable with an a vowel are reduplications:

pangu-pangu-rnu			pangi-pangi-rni
dig	-Past	vs.	dig -NPast

and a textual example:

- (55) Palya-ngku-rna-lu jarntu-jarntu-rnu  
 adze- Erg- lll trim -Past  
 'We trimmed it with an adze.' (Hale, 1959:592)  
 (cf. jarnti-rni (trim-NPast))

In other words, the reduplication rule (47) is activated subsequent to the (morphologically triggered) regressive vowel assimilation. Contrast this with the determination of suffix allomorphy by a reduplicated nominal stem, 4.2 (there are, important differences between verbal and nominal inflexions, see 2.2).

The "overapplication" of the morphophonological vowel assimilation rule to reduplicated forms is one type of situation considered by Marantz, 1979, using the morphological theory presented in Lieber, 1980. In this view, a root such as pangi 'to dig' has its two allomorphs listed in its lexical entry, i.e. {pangi, pangu}, and the suffix such as Past rnu selects an allomorph of the root (in this example, pangu). Reduplication is so formalized that it is forced to choose the same allomorph. Thus, pangu-pangu-rnu (rather than \*pangi-pangu-rnu) occurs, not because of an ordering of the reduplication rule after the vowel assimilation rule, but rather because the suffix pre-empts the choice of root-allomorph.

Marantz, 1980 subsequently proposed a formal theory of reduplication, wherein it is seen as an affixation of a skeleton of segments specified only as C or V, with a simultaneous copying of the phonemes of the stem to which the reduplication skeleton is attached. Thus, in Warlpiri verbal reduplication, the skeleton might be specified as

CVCCV

and a form such a pakarni undergoes reduplication simply by affixation of the skeleton (as a prefix), with the phonemes of the stem automatically copied across on a parallel tier:

p a k a r n i	+	p a k a r n i
⋮ ⋮ ⋮ \		
C V C C V	+	C V C V C V

and then, by universal convention, association lines are drawn (as indicated by dashed lines).. By another universal convention, unattached elements (in either the skeleton tier or the phoneme tier) delete, and paka-pakarni results. It should be clear why Marantz would not propose a skeleton CVCCVC for this Warlpiri reduplication -- for otherwise the output \*pakarnpakarni would be produced.

How then to handle reduplications where the coda of the second syllable is copied? (as in jamparl-jamparl-nga-rni, etc.) Marantz proposed that all such instances are in fact the result of a separate reduplication rule, of the sort "Copy first morpheme". This view gains support from the facts of Tagalog reduplication, for instance (Carrier, 1979:81), where a final consonant is reduplicated if and only if it is morpheme-final. And such a "morpheme-copy" rule would also handle the monosyllabic preverb reduplication of (52)-(54). It remains to be explained, however, why the other option of reduplication is not available to these monosyllabic preverbs, i.e. the account does not explain (in its present form), why the forms in (50) are ill-formed.

Marantz's account does, however, deal naturally with a converse situation, in which a syllable-final consonant fails to be copied by reduplication. Examples of this arise with monosyllabic preverbs with a long vowel:

- |                          |                                      |
|--------------------------|--------------------------------------|
| (56) tii-tiirl-parnka-ja | '(ground) split lengthwise (by tuber |
| split-run-Past           | underneath)' (Hale, 1966:153)        |

The skeleton-theory handles such an example as shown in this diagram, where the associations effected by convention are represented by dotted lines:

t i i r l ( p a r n k a j a )	+	t i i r l p a r n k a j a
⋮ ⋮ ⋮ \		
C V C C V	+	C V V C C V C C V C V

(Note that the phoneme tier takes priority -- one works from left to right along that tier associating whatever possible to the skeleton.)

The output is, correctly, (56). And it makes the further prediction that, were a short-vowelled monosyllabic preverb to reduplicate, the final consonant could not be dropped:

(?)    t i r l (p a k a r n i) + t i r l p a k a r n i  
           | | |                                   | | | | | | | |  
           C V C C V                           + C V C C V C V C V

To derive this result, however, requires an extra assumption which has not made any difference in previous examples. We need to assume that only part of the phoneme tier of the word to be reduplicated is copied prior to association to the skeleton: hence the parentheses around the unwanted part of the stem in the last two examples. The move indicated, especially in the light of the foot-copying rule (47) above, is to specify that the phonemes associated with the first foot of the word to be reduplicated are copied, ready for association to the skeleton tier.

Marantz, 1980:2 had hoped to avoid placing such a metrical condition on how much of a word is reduplicated, and indeed in the sample of languages he consulted it is never "the case that a language reduplicates a foot, syllable, or any other sub-morphemic constituent save a C or a V". His sample, however, did not include another Australian language, Yidin<sup>y</sup>, in which reduplication copies the first two syllables of a noun. The rule needs to be formulated in terms of syllables, since it copies only the first two syllables of a three-syllable root, and takes the coda of the second syllable, as in these Yidin<sup>y</sup> examples:

mularri	'initiated man'	mulamularri	'(plural)'
kintalpa	'lizard sp.'	kintalkintalpa	
kalamparaa	'March fly'	kalakalamparaa	

(Dixon, 1977:155,233; orthography changed; discussed in Nash, 1979:114, where homorganic nasal-stop clusters are argued to be tautosyllabic and onsets rather than codas).

Given this refinement to Marantz's approach, it may be embraced for Warlpiri. The prediction it makes, that forms such as \*ti-tirl-pakarni will not be found, is borne out in the data to hand, but it must be remembered that these monosyllabic short-vowelled preverbs are not very common in the first place.



## 4.4.2 SEMANTICS OF VERBAL REDUPLICATION

The semantic effect of verbal reduplication is basically that of "intensification". For instance, the "attenuation"-type effect observable in some nominal reduplication is not found among reduplicated verbs. In particular contexts, or with particular verbs, the type of "intensification" may be (i) plurality of an argument, (ii) distributivity with respect to an argument, (iii) increased speed of activity denoted by the verb, (iv) repetition of activity denoted by the verb. Of course, these categories fade into one another. Examples of each are given according to the above categories.

(i) plurality (of subject or object)

See (32), (33), (35), (38) above, and:

- (57) Jiwinypa-rlu ka-ngalpa luwa<sup>2</sup>-rni-rni.  
 wood chip(s)-Erg Pres-122 shoot-NPast-hither  
 'Wood chips are hitting us.' (Hale, 1959:768)

In recent years this process has generalized somewhat, so that speakers often reduplicate an entire verb when it has a plural subject<sup>2</sup>. Thus, there is one instance of reduplication of a three-syllabled verbal word (in the writing of an 18 year old):

- (58) Yawulyu-wardingki-patu ka-lu warrka-rni warrka-rni  
 women's ceremony-people-several Pres-333 climb-NPast climb-NPast  
 turaki-rla Yalikarangu-ku-ngarnti.  
 vehicle-Loc (place name)-Purp-Preparative  
 "The Yawulyu women are climbing on the vehicle for the trip to  
 Yalikarangu." (Junga Yimi 1.4:12)

This verbal "repetition" is more akin to the formation of nominal plurals by reduplication, and is to be distinguished from the verbal reduplication being considered in this section.

(ii) distributive

The clear examples of distributive (*vis à vis* plural) are with a

---

<sup>2</sup>I am grateful to Mary Laughren for bringing this to my attention. Laughren also suggests that this innovation has been introduced by younger speakers.

singular subject (grammatically and referentially) of an intransitive verb, as in:

- (59) Nungu ka nguna<sup>2</sup>-nja-rni ya-ni.  
sugar Pres lie-Inf-hither go-NPast  
'The (best) sugar lies from one end to another (of the  
sugarbag, i.e. native beehive).' (Hale,1959:776)

and (37) above, and (60), (61) below.

Other examples involving distributivity are (34) above (a subject noun unmarked for number, but with plural agreement clitic). Other examples with spatial distributivity may be:

- (60) ...ngapa-lku ka wanti<sup>2</sup>-mi palka-lku -- nguru-ngurlu  
rain water-then Pres fall-NPast present-then sky-from  
kankarlarra -- ngapa-ju ka wanti<sup>2</sup> walya-kurra-lku.  
above rain-Top Pres fall ground-All-then  
'...then the rain is really falling, from the sky above; the  
rain is falling to the ground.' (Hale,1966:452)

- (61) Purturlu-jangka ka yangka jiti<sup>2</sup>-mi-rra ngapa,  
ridge-from Pres that descend-NPast-forth water  
ngawarra-lku ka parnka-mi-rra wirri-ngka-lku.  
flood-then Pres run-NPast-forth watercourse-Loc-then  
'The water runs down off the ridge, then the flood runs away  
in the watercourse.' (Hale,1966:472)

Distributivity with respect to subject and object arguments may be present in:

- (62) Yurlpa-ngku ka-lu-nyanu mapa<sup>2</sup>-ni.  
red ochre-Instr Pres-333-Recip run-NPast  
'They are rubbing themselves with red ochre.' (Hale,1959:764)
- (63) Jinjirla-lu-nyanu yirra<sup>2</sup>-ka.  
fluff-222-Recip put-Imp  
'Put the fluff on yourselves.' (Hale,1959:761)

(iii) speed

The clearest example of verbal reduplication to express fastness of

speed is in (32), where the adverbial "quickly" co-occurs. Another example is (40), and possibly others that have already been mentioned in other categories.

(iv) repetition

Repeated action, but also spatially distributed, is expressed in:

- (64) Parnti-nyangu-palangu -- nga-rnu-lpa ngurra-lku  
 smell-Past-33object eat-Past-Imperf home-then  
 walya-lpa [nga-rni]<sup>2</sup>-nja-ya-nu -- yuwayi, yangka  
 ground-Imperf eat-Inf-go-Past yes that  
 maliki-piya-rlu.  
 dog-like-Erg  
 'He smelled the two -- he was eating home, he was going  
 eating dirt -- yes, that one was acting dog-like.' (Hale, 1966:861)

This is also true of (36) above. Another example is:

- (65) Mijilypa ka karli<sup>2</sup>-mi-rni.  
 sap Pres flow-NPast-hither  
 'The sap flows out in successive spurts.' (Hale, 1959:835)

## 5.1 WORD ORDER

The role of word-order in grammar is a perennial topic. In this section I review research on word-order that has appeared in the last fifteen or so years and broadly classify the ideas about word-order that have been proposed in that time, so as to help clarify the position taken later with respect to the role of word-order in Warlpiri grammar.

A good review was made by Bach, 1975, in one of thirteen papers on "Word Order and Word Order Change" presented at a January 1974 conference. Chomsky, 1965:124-26 and Stewart, 1976 have given briefer reviews. And I should mention the basic typological study of word-order in Greenberg, 1963 and the subsequent Steele, 1976.

Bach classifies various theoretical positions about word-order in terms of how they would be represented as hypotheses about the phrase-structure base rules of a generative grammar. He distinguishes several such "systems", of which I repeat two here:

L-system ('L' for lattice): The elements dominated directly by a given category constitute simply a set of elements. The entire operation of the base rules then give objects which are simply stratified sets of elements: the entire marker is a set S consisting of, say, two elements NP and VP: {NP, VP}; NP and VP in turn are sets of elements, node labels, and so on.

(Bach, 1976:313, with minor changes)

M-system ('M' for mobile): A system which at each point generates (ordered) strings of elements but in such a fashion that from a rule

$$\underline{A} \rightarrow \underline{B}_1 \underline{B}_2 \dots \underline{B}_n$$

any permutations of the B<sub>i</sub> would follow from the application of the rule. Such a system would directly generate ordered phrase markers in the usual sense. It would be equivalent to a grammar in which the following condition is met: 'R is a rule of the grammar if and only if every rule which is just like R except that the elements on the right are arranged in a different order from that of R is also in the grammar.'

(ibid.)

Proponents of L-systems have included Curry, 1961 and Shaumjan & Soboleva, 1963, Sharmjan, 1964. (Curry and Shaumjan's work is assessed by Chomsky, 1965:221n34, and Hall, 1964 reviews Shaumjan & Soboleva). Staal, 1967 introduced the term wild tree to name the phrase-markers generated by an L-system.

These authors have been primarily studying languages (Russian and Sanskrit, respectively) which exhibit considerable variation in the allowable word-order of surface sentences. Others who have been concerned with languages with less freedom of word-order have also proposed base rules of the L-system type, but has also had to discuss the linearization processes, whereby specific orders are assigned to the "wild trees". In addition to stratificational grammarians (Gleason, 1964, Lamb, 1966) and Sanders, 1969, 1970, as mentioned by Bach, one might include here Chafe, 1970:esp. 250-7, Hudson, 1972a, b, Hetzron, 1975, and Relational and Arc-Pair Grammars (Postal, Perlmutter, and others, who use a relation of Linear Precedence). Anderson, 1976 sees "serialisation" as a generalisation over immediate post-cyclic (shallow) structures, noting that Bach's, 1975 considerations in favour of deep order do not involve any probably cyclic processes (except for Extraposition?). Consonant with independent work by Hudson, 1976:108, Anderson, 1976 sees the modifier-head relationship as the main (sole?) determinant of word-order within a given language.

Another view has been taken by the Prague school linguists such as Matnesius, Firbas, Sgall and Daneš (e.g. Daneš, 1967), and others such as Werth, 1977. These linguists see linearisation as governed by functional and discourse factors. Similarly, Dixon, 1972:149 ends up advocating a "discourse-generating component" acting on (ordered) trees in his treatment of Dyirbal. More recently, the claim that word-order is outside grammar proper has been made by Ades & Steedman, 1979:3, who argue "that the grammatical word orders are constrained by the nature of the mechanisms which process sentences".

#### PROBLEMS WITH "WILD TREES"

Bach, 1975:320 sees Lyons, 1966 and Staal's, 1967 approaches "as pointing toward M-systems rather than true unordered base systems", and shows that M-systems are a stronger theory of the base than L-systems (with standard phrase-structure rules being intermediate in strength), and

points to Peterson, 1971 as a clear example of an M-system. Boas, 1975:170-72 also demonstrates the equivalence of Staal's and Peterson's proposal, and the property they share of, essentially, not being "wild enough".

Dixon, 1972:147-48 considers Staal's, 1967 system as a possibility for Dyirbal grammar, but points out one respect in which it would undergenerate, one summarized by Bach, 1976:314 :

the constituents will be grouped according to the dominance relations expressed by the rules and only those orders conforming to this grouping will be generated by the rules. Thus an M-system with the two rules

S : NP, VP  
VP : V , NP

will yield only the four permutations (marking the NP's to distinguish them):  $NP^1 V NP^2$ ,  $NP^2 V NP^1$ ,  $V NP^2 NP^1$ ,  $NP^1 NP^2 V$ : no arrangement in which two constituents are separated by a constituent of another construction will be generated.

As Boas, 1975:175 n15 (on p.238) points out, Staal himself recognised this problem with "wild trees":

This failure itself is one of the arguments which favours the assumption that word order cannot be described in terms of trees, whether trimmed or wild.

(Staal, 1967:79n6)

#### 5.1.1 FREEDOM OF WORD ORDER

For languages which exhibit a freedom of word-order greater than that produced by Staal's system, further scrambling rules would need to be added, as for instance entertained by Dixon, 1972:148 for Dyirbal.

This is obviously the same as a system consisting of a set of context free rules and a 'scrambling' rule which rearranges the terminal strings of the CF grammar into arbitrary orders. Let us call such a system an S-system ('S' for scrambling).

(Bach, 1976:314)

Boas's, 1975 proposal, informed particularly by his study of word-order variation in German, and building on Staal, 1967, proposes a freer interpretation of "wild trees", using as an analogy the "mobile".

This is different from the use of that term by Bach (quoted above), one that would allow a greater range of orders than envisaged in Bach's use of the term:

it is suggested that a labelled unordered set be viewed as corresponding to a tree-like mobile the branches of which may cross each other if it is projected onto a two-dimensional plane.

(Boas,1975:189,cf. p.174)

This agrees with an apparently independent use of the "mobile" metaphor by Stewart, 1976:155-59, attributed by her to "William G. Moulton (personal communication)". Thus, a Boas/Moulton-mobile with the two rules

S : NP, VP  
VP : V., NP

would yield all six possible orders of  $NP^1 V NP^2$  (cf. the four given by a similar "M-system", above). Hence it produces the free-est possible word-order.

### 5.1.2 HYBRID LANGUAGES AND TYPOLOGICAL VARIATION

Some workers have suggested that there are languages with two different sorts of constituent: constituents which expand in a fixed order of sub-constituents, as well as constituents which allow freedom of order within their boundary. The most discussed example is English, wherein the VP constituent (but not, for instance the NP) has been proposed to have free order of its immediate sub-constituents. Bach, 1975:315 mentions such suggestions as involving a base-order as a partial ordering, and cites Fillmore's, 1968 case system as an example:

His proposition consists of a Verb followed by one or more case categories which may or may not be ordered with respect to one another.

(Bach,1975:315)

Keyser's, 1968:368 "Transportability Convention" has much the same effect. He uses it to govern adverb-placement within the English VP, where it

permits a particular constituent to occupy any position in a derived tree so long as the sister relationships with all

other nodes in the tree are maintained.

Whitman, 1979 subsumes much the same phenomenon (including PP's and NP's within the English VP) in a general principle with which he is able to make headway on problems in Japanese syntax:

The Contiguous Identical Category Hypothesis

Linear order of contiguous constituents of the same syntactic category is free, subject to the restrictions of semantic interpretation.

(Whitman, 1979:4)

(He has to assume, of course, that PP and NP are "generated as members of a single syntactic category:, at least in English).

Keyser, 1968:372 suggests that his proposal might be extendible to the freer word-order in Latin, simply by marking more constituents than just the VP as "transportable". Ross, 1967 does much the same as this in his account of Latin "scrambling": "Two major constituents can be permuted inside of the same phrase". Thus, the extreme case where every constituent is marked as "transportable" ("permutable", "scramblable") is equivalent to assigning the language an L-system or virtual M-system (in Bach's, 1975 terminology).

A quite powerful device for generating "discontinuous constituents" was proposed by Yngve, 1960:449. He added to a base with ordinary concatenation phrase-structure rules other rules, of the form "B = D + ... + E", where the " ... " represented a gap into which all "sisters" of B must be ordered. (The English verb-particle construction is most suggestive of this innovation.) Thus, if the expansion of B according to the rule given is ordered after the expansion A = B + C, the string "D + C + E" results. It would presumably follow (in the absence of a stipulation), that D and E together no longer "is a" B. A superior device, at least notationally, would be to co-index all the immediate daughters of a node which are introduced by the expansion of that node - something like "D<sub>B</sub> + C<sub>A</sub> + E<sub>B</sub>" for the above string. One can then read the discontinuous constituents off the output string.

This improvement is tantamount to Harman's, 1963:606ff "discontinuous-constituent phrase-structure grammar with subscripts and deletes" (from its description by Boas, 1975:239, at least). But these additions to the basic



phrase-structure concatenation rules still cling to the notion "syntactic constituent" as the model for all discontinuous expressions, which may be a mistake. The "continuous" expressions do have properties additional to those of other expressions, by virtue of their continuity. As Stewart, 1976:158 puts it:

one pays a price for the advantage of not having to represent discontinuity, and that is not being able to represent continuity. It is not possible to show the linearity that is, after all, characteristic of speech if not of grammatical structure.

One needs a model which simultaneously recognises linear ordering and the possibility of "discontinuous expressions".

Before continuing our search for a suitable model, we might briefly consider what the prime candidates are for "discontinuous expression". In English, the verb-particle construction has often been cited, but so may be many workable alternative analyses which avoid treating a separated verb and particle as a constituent. Clearer examples arise in inflected free word-order languages, where modifiers and heads, for instance, occur separated by other words. For such "expressions", the indexing suggestion entertained above would appear to have linguistic reality in the inflexional morphology of concord markers: "co-indexed" is realised as "marked with identical surface case".

Thus it is not surprising that there have been a number of proposals to "base-generate" case-markings in the grammar of such a language. This has had other motivations, of course, so that base-generation of case has been combined with a fixed-order base and subsequent scrambling rule(s), or a "mobile"-base with an effect of "case percolation" (Staal, Boas). But given the viability of semantic-interpretation rules which would allow the creation of a single (non-syntactic, semantic or logical) expression from non-contiguous syntactic constituents, it was reasonable to investigate the possibility of free generation of case-marked N's (or NP's) by the phrase-structure rules. Given the free order simultaneously being addressed, a natural proposal was sketched in Hale, 1976:125, 1977:409ff for Warlpiri and its like, wherein "the categorial rules of the base are of the form

$$X^n \rightarrow \dots, A, X^{n-1} "$$

i.e. conform to those of an L-system, as defined by Bach retaining the "head" notion of  $\bar{X}$ -theory. Hale's innovation was in proposing a typological

difference between languages with respect to their base structures, viz. whether the base was a standard transformational grammar base of the  $\bar{X}$ -type, or of the L-system type. Previous proponents of L-systems, etc. had, to my knowledge, seen them as being of universal application to human languages, with language variation occurring in the operation of subsequent rules, including the ones effecting linearisation. Admittedly, unordered phrase-structure expansions were advocated for just a few nodes in a particular language (what I have called "hybrid" accounts) - from which it is an easy step to envisage typological variation along a cline of strictness of order. Carrier, 1976 compared two approaches to Warlpiri grammar, of which one, the "Free-Order Proposal" (p.4) was an elaboration of Hale's proposal, with base-generated case-marked N's, and an L-system type base. Her other approach, the "Fixed-Order Proposal", was an S-system in the sense defined by Bach, 1975:314, quoted earlier, with case-marking by rule. Carrier details how each approach might confront various Warlpiri constructions, and sets up a number of test-sentences which, according as they are grammatical or not, might constitute evidence for one of the approaches or the other.

Chomsky, 1965:125 has criticised L-systems on grounds other than on undergeneration (above). He argues that they do not allow a derivation for a particular sentence from its unordered underlying representation. At least, the only way grammatical transformations can apply to give a derivation is if an intrinsic order is first assigned to the elements of the underlying unordered phrase-marker of a particular sentence. Hale, 1977:410 is explicit about the possible presence of a transformational component in a language's grammar: if the language has a base which is an L-system, then by definition of "transformation" (as a structure-dependent operation on concatenated constituents), the language cannot have a transformational component.

Boas, 1975 devotes a good deal of his book to a review of and disagreement with the passage from Aspect... mentioned above. But since our proposal is different from Boas' "mobile" system, and since the lack of a transformational component is conceded, I shall not review his arguments. What I am concerned to do here is place the proposal that will be advanced in a later section for Warlpiri grammar within the attempts of linguistic theory to deal with variable word-order.

To generate all the possible word orders in Warlpiri, an L-system base would have to be supplemented by scrambling rules, however, as discussed above. The only hope for an L-system would be if it contained just one rule, presumably of the form

$$\bar{X} \rightarrow \dots, A, X$$

and thus where no item on the right-hand side of the rule is expandable by any base rule (otherwise the sort of two-level dominance will arise which will call for scrambling rules). Hence each item on the right-hand of this rule must be a word, and X cannot range over more than one value. Taking the universal terminal symbol to be S, we can see that this rule is virtually equivalent to the single rule

$$(1) \quad S \rightarrow W_1, W_2, \dots, W_k$$

where each  $W_i$  is specified to be no more than just a single word.

The approach to Warlpiri grammar to be developed below is in this spirit. The base is not the source of structure in Warlpiri, in this view. Rather, it is the result of a number of "parsing" rules, rules of semantic interpretation, which build up the relations between the words of the sentence according to the Case, Complementiser, and Argument markings on each of the words, and using the placement of the Auxiliary and various "punctuational" information. This will be developed later - the point to appreciate here is the further departure Hale, 1979 has made in the conception of the base. If the above line of reasoning is followed to the point where the base "structures" of Warlpiri are described by the one rule (1), then the sole contribution of the rule is to label a set of words as constituting a sentence, S. But this labelling can just as well be done within the extensive labelling already envisaged in the semantic interpretation component - there is no reason for separating the labelling of the entire proposition off from the labelling of its constituents.

And rule (1) has been stripped of the one other general function of base rules, viz. providing a linear order of constituents. This has been relegated to some late linearisation process, in the approach which (1) would be a part of. Hale's innovation amounts to dispensing entirely with the base, and beginning a derivation instead with the linearisation of the right-hand side of (1). Hale, 1979:3 symbolises this as

(2) E → W\*

(using the "star"-notation from the abbreviatory convention of generative phonology). This is merely a device to present the parsing component with strings of (fully-inflected) words. The symbol E (for 'expression') will thus cover non-sentences as well as sentences, for there are some sequences of words which cannot be assigned a consistent semantic interpretation. The form of (2) being congruent to that of a phrase-structure rewrite rule is, in fact, a survival from previous approaches, like (1) and before.

This alternative to  $\bar{X}$ -phrase structure, where the merging of lexical elements into constituents is done by a "bottom-to-top" labelling rule-type, rather than an  $\bar{X}$ -type expansion rule, has been investigated for Japanese syntax by Farmer, 1980, for Ngarluma by Simpson, 1980, and has been sketched for Old French by Dubuisson & St.-Amour, 1979. Bouchard, 1979 embraces the rule (2) "as a unique base for all languages" (p.14), preferring to construct even the  $\bar{X}$ -type structures of English and French by "functional labelling ... based on a constituent merger".

In a so-called  $\bar{X}$ -language, the language will have a list of merging labels that operate somewhat like inverse phrase-structure rules.

(Bouchard, 1979:15)

Merging labels are optional in principle, but since they provide essential information for the full labelling of the sentence in languages that do not have as strong a morphological labelling as Warlpiri, they turn out to be practically obligatory for languages like French or English.

(ibid.)

It may prove possible to follow Bouchard's lead and extend the account of the phrase-structure given for Warlpiri below to languages of a different typological character, and discussion of this is beyond the goals of this work. However, some reasons for making the necessary typological distinctions partly by recognising various sorts of base-components are mentioned below, 5.5.

### 5.1.3 WARLPIRI AS A "SCRAMBLING LANGUAGE"

It is instructive to attempt a formulation of the basic grammar of Warlpiri on the assumption that it has an ordered base, with Phrase-structure Rules within the  $\bar{X}$ -theory, and with Transformations and other rules then applying to generate the observed grammatical sentences.

The first attempt to do this, within the framework of Chomsky, 1965, was made by Hale, 1967, 1968. That approach proposed base structures for Warlpiri which would be considered "very deep" from the point of view of the descendants of that framework. For instance in Hale's account:

- (i) noun-adjective combinations (syntactically, two adjoined N's in Warlpiri) "are developed by reduction of relative clauses" (1968:8);
- (ii) "tense, mood, and aspect are basic to the auxiliary" and "a rule ... suffixes to the verb a duplicate of the auxiliary base", which is then realised as a tense/aspect suffix morphologically unrelated to the auxiliary base it is interpreted with (1968:60,n24);
- (iii) N-[V-Nomic] compounds (2.4.1) are derived by rule from underlying finite simple sentences (1967:12);
- (iv) the subject and object clitic person/number-markers are transformationally derived (by means of a copy-adjunction to a deep AUX node of the obligatory "DET" (pronoun) component which is base-generated with every NP and optionally deletes later when sister to the NP) (Hale, 1968:30). The subject person-markers have to be derived before the putative passive rule applies, and the object personmarkers after it.

Furthermore, Hale explored the possibility that transitive (two-argument) clauses in Warlpiri were all of the same structure, but that the ERG-ABS surface clauses (as opposed to the ABS-DAT ones) were generated by means of a Passive rule, which would apply obligatorily in the presence of a marker AGT associated with the lexical entry of certain verbs (i.e. the verbs taking ERG-ABS case frames on the surface) (1968:32, etc.). He was able to adduce several ingenious pieces of evidence for this proposal, but also pointed out some serious problems for it (1968:61-66, nn28-29, 31-33).

However, other rules proposed by Hale, 1967, 1968 have been less affected by the theoretical developments towards a more interpretive grammar that mark the evolution of formal grammar since Chomsky, 1965 to the following processes, and their orderings, can easily be entertained within a Revised Extended Standard Theory framework; perhaps with formal

modifications of Hale's precise presentation of them, but essentially the same as he proposed them;

- (v) R-Embedding-Shift, which "shifts an embedded S to a sentence-final position" (1967:19), triggered obligatorily by "the mere presence of an ending in the verb (complementizer, relativizer, or the like)" (1968:53n4).
- (vi) R-Node-Erasure/Splitting, which "operates on nodes intermediate between S and the lowest order category nodes (N,V,etc)", splits them, and "reattaches their former constituents to the next node up" (usually S). (Hale, 1967:5, as amended in Note 13, p.35). This rule is optional, and ordered before R-Permutation.
- (vii) "topicalised" NP's are moved to pre-sentence position by a rule "R-Topic" (1967:7).
- (viii) "a late transformational rule (R-Permutation) ... optionally permutes (or scrambles) non-auxiliary immediate constituents of S" (1967:2). This rule was optional.
- (ix) "the surface positioning of AUX is effected by a rule, R-AUX-Shift, which simply permutes a S-initial AUX and the immediately following S-constituent (optionally if the auxiliary is disyllabic or longer)." (1967:6). "The only rules which clearly must follow R-AUX-Shift are phonological": it follows the rules mentioned in (vi-viii).

R-Embedding-Shift is not crucially ordered, but, depending on how it is formulated, is probably best written to apply before R-AUX-Shift (which might otherwise destroy its structural description). The transformational component can be given the following ordering structure:

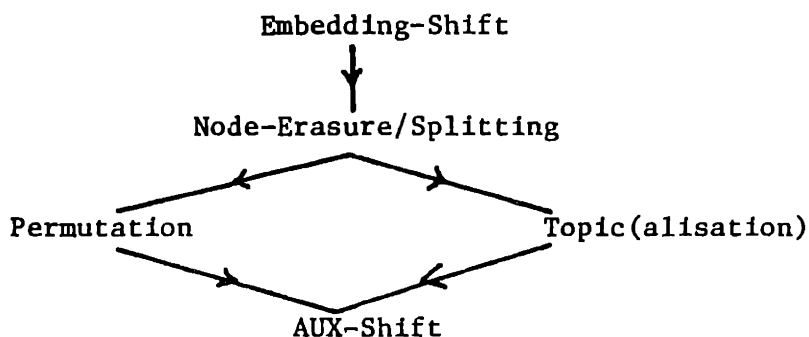

More recently, Hale, 1979:14-23 has sketched what a scrambling analysis for Warlpiri would involve within the Revised E.S.T. framework

(with a "T-form" grammar, Hale, 1979:20, after Chomsky & Lasnik, 1977, etc.). A basic word order for each clause has the Auxiliary in initial position, and a late rule places it (optionally or obligatorily, depending on phonological factors) after the first constituent (of S). Before this applies, a general scrambling rule "reorders the words of a sentence, without regard to their membership in a larger subclausal constituent" (p. 15). This interacts with the splitting of a non-terminal node, a process which copies case-features onto the results of the splitting: it makes the resulting units available for scrambling, or perhaps is an integral part of the scrambling rule. These processes, and their ordering, are essentially the same as the rules (vi), (viii), (ix) mentioned above, surviving from the earlier-style account.

Further research on Warlpiri has drawn attention to a less frequent type of construction, not described in Hale, 1967, 1968, but which has interesting implications for the scrambling approach.

There must be a process allowing Percolation of case and complementiser features from a non-terminal NP-node to the N-nodes it dominates, without breaking up the NP-node (as Node Erasure would do), because of the possibility of sentences such as (1) (Hale, 1979:16, sentence (16')):

- (1) Kurdu-ngku wita-ngku ka maliki wajilipi-nyi  
 child-Erg small-Erg Pres dog chase-NPast  
 'The small child is chasing the dog'

which would have a surface structure as in (2), in the scrambling view:

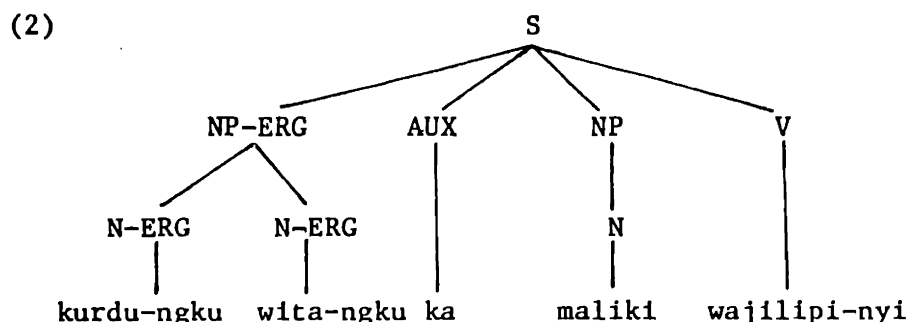

and a more remote structure (3):

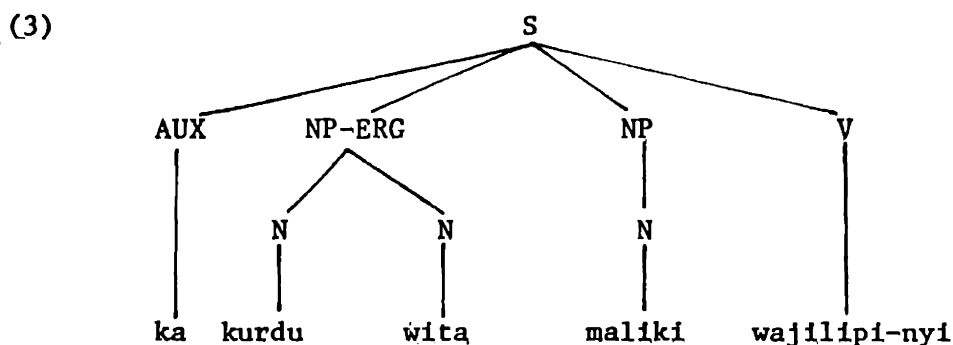

In other words, the case-feature represented by "ERG" in (3) may be spelled out on the last word in the constituent bearing the feature as in (4):

- (4) Kurdu wita-ngku ka maliki wajilipi-nyi.  
(same meaning as in (1))

or it may appear on every word in that constituent, independently of AUX-Shift.<sup>1</sup>

The process of percolation just presented is a necessary part of Node-Erasure (reformulated as Node-Splitting, as in Hale, 1967:35n13 and Hale, 1979:15-16, which is not only ordered before AUX-Shift, but is an optional operation in its own right ordered after AUX-Shift. This seems to be missing a generalisation - viz. that (1) above, and (5), both involve the one operation of "case-spreading" in their derivation.

- (5) Kurdu-ngku ka maliki wajilipi-nyi wita-ngku.  
child-Erg Pres dog chase-NPast small-Erg  
(same meaning as (1), but other readings as well)

derivation of (1)

{ AUX-Shift  
Percolation

derivation of (5)

{ Percolation  
Node-Erasure/Splitting  
Permutation  
AUX-Shift

And there are sentences which would require two applications of Percolation in their derivation, before and after AUX-Shift: at least, sentences like (6) below are most likely as grammatical as ones like (1),

<sup>1</sup> These processes do not apply quite so neatly with respect to infinitival complements that have associated nominal objects: see Hale, 1979:17-20.



though neither are at all common in Warlpiri texts.

- (6) Kurdu-ngku wita-ngku ka maliki wajilipi-nyi yalumpu-rlu  
 child-Erg small-Erg Aux dog chase-NPast that-Erg  
 'That small child (near you) is chasing the dog'

Derivation of (6) involves these rule applications:

- (7)                    { Percolation  
                          { Node-Erasure/Splitting  
                          { Permutation  
                          { AUX-Shift  
                          { Percolation

However, a derivational history such as (7) is by no means aberrant, and the double application of the one rule does correspond to the different character of the "spread" case in different parts of the subject expression in (6).

Insofar as the above captures a reasonable fragment of Warlpiri, it bears out Hale's remark, 1979:21, :

Although problems of detail clearly abound in an X-bar theory of Walbiri grammar, it seems to me very unlikely that such a theory could not be made to work.

In 5.5 I mention some points (e.g. the lack of "gaps" in Warlpiri) which might be used as evidence against the X-bar theory approach. And we might add to Hale's mention of some "counter-indications":

... most disturbing -- that is, disturbing for a defender of a theory such as that presented in this section -- is the fact that syntactic or morpho-syntactic arguments which might otherwise be marshalled in support of a scrambling-rule analysis of discontinuous expressions typically fall through.

(Hale, 1979:22)

Hale cites the "vague-predicational" usage of complementiser-marked nominals (7.3). One might add the observation that Warlpiri lacks movement rules from tensed clauses (Hale, Jeanne & Platero, 1977:410-411) as well as "VP-Deletion" (except for an "echo" or "tag" use of a repeated Auxiliary).

Such considerations along with the remarkable freedom of word-order

and discontinuous expressions within tensed sentences, spurs the investigation of the alternation approach to Warlpiri of the following sections.

## 5.2 MODEL OF THE GRAMMAR

My aim in the remainder of this work is to present a partly-formalised account of Warlpiri syntax and certain aspects of semantic interpretation against which other views (informed by different assumptions, perhaps) may be measured. Its articulation is based on Hale, 1979, but departs from his proposal in some respects.

I assume the generative model of organisation of the grammar schematised in the following chart:

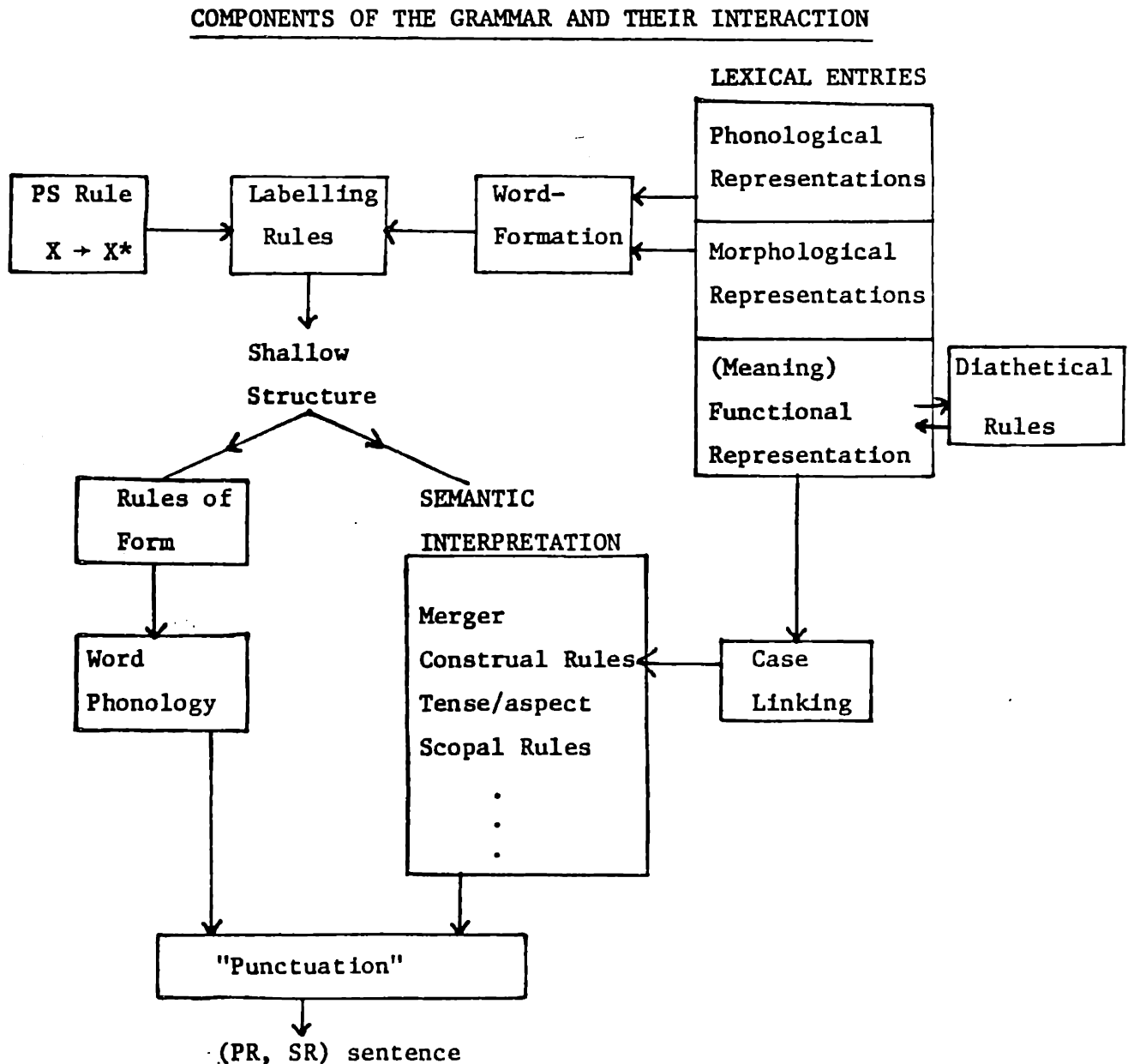

It is clear from the chart that I follow a number of assumptions of the grammatical tradition summarised, say, in Chomsky, 1980:1-6, and the references cited there. However, there are a number of important differences. This approach to Warlpiri has no transformational component, and since the base, or phrase-structure component is at variance with what one would expect from a model within that tradition (expectations built from analyses of "configurational" languages within that model), many aspects of the "Extended Standard Theory" which have been debated in the past few years are irrelevant here. Thus many of my assumptions are also those of Bresnan's "Realistic Model", particularly in the emphasis on the importance of functional structure. Another departure concerns the addition of a "Punctuation" component, which makes joint use of phonological and semantic representations. Its role in the grammar was suggested in Hale, 1979:48, and I have little to say about it in the work. It is included as the locus of various intonational and scopal interactions which are not investigated here. Further remarks on theoretical assumptions are in 2.2 (Lexicon), 3.5.6 (non-segmental phonology), and 7.1 (semantic interpretation).

The remainder of this section deals with the phrase structure rule proposed for Warlpiri.

Following one suggestion by Hale, 1980:200, I propose that Warlpiri has just one Phrase-Structure rule, viz.

$$(1) \quad X \quad \rightarrow \quad X^*$$

This phrase-structure rule looks like the one which in general provides co-ordinate structures. In some languages, there may be some categorial content specified in the rule, though in the usual suggestion for English there is none for X -- hence Jackendoff's, 1977:51 use of " $X^i$ " unspecified further for categorial content in his (3.35)  $X^i \rightarrow X^i - (\text{conj} - X^i)^*$ .

But there is a fundamental difference between (1) and say, Jackendoff's (3.35) just quoted. For Jackendoff, and generally in the use of X-bar notation, an "X" stands for the range of categories which fit the restrictions specified in "X". Thus " $\bar{X}$ " means "all one-bar-level categories", [+N] means all categories, irrespective of bar-level, with the value "+" for category feature [N], and so on. Thus X is a "category-variable", used in its usual sense; the rule (3.35) of Jackendoff says that only identical categories may be conjoined.

I am proposing (1) in the sense that there is no category information in "X" unless explicitly given. If this were the interpretation of Jackendoff's (3.35), it would say that any category (at the  $i$ -th level) may be conjoined with any other, e.g. an  $\bar{N}$  and a  $\bar{V}$ , which is not what it in fact abbreviates. Thus my (1) is meant to amount to an expansion of an unlabelled node into an arbitrary number of unlabelled daughter nodes. It licenses, in effect, any unlabelled tree. Because of this potential source of confusion, it may be preferable to stick with the version of (1) as Hale, 1979 proposed it, viz.

E → W\*

(see 5.1.2). However, Hale's proposal does not allow any non-terminal syntactic nodes: the terminal "nodes" are well-formed words, produced by the word-formation component, and the only sort of non-terminal "node" is a complex expression built by rules of semantic interpretation. I am exploring the variant in which there may be non-terminal syntactic nodes. These are the nodes which receive Labelling (5.4) by "climbing" of categorial content.

However, to deal with the "discontinuous expressions", this approach will build semantic expressions which do not correspond to a single syntactic expression -- just as Hale, 1979 proposes for any level above that of the word.

My reasons for this departure are perhaps not compelling, but it does allow a distinction between expression types which is at times useful. The primary function of the non-terminal syntactic nodes (other than as bearers of category labels, given by the Labelling rules) is to allow a statement of the placement of the Auxiliary (5.6); in turn, the facts of AUX-placement provide information and tests for the formulation of the labelling rules below. Non-terminal syntactic nodes also provide units for the application of semantic interpretation rules (although the Merger rules (7.2) also build units of similar type out of "discontinuous expressions".) Further, the notion of governor (7.1) is defined in terms of the syntactic structure produced by Labelling (5.4).

The absence of "bars" in Warlpiri phrase-structure is equivalent to claiming that there are no structures with syntactic heads -- heads imposed, that is, by a PS-component. This claim does seem to be borne out

to a significant extent in Warlpiri. But pushing this claim to extreme (asserted here by allowing no other PS-rule than (1)) means that head-like behaviour, where it does occur in Warlpiri, is attributed to Labelling Rules or semantic interpretation rules.

Seen as a syntactic filter, the PS-rule (1) effectively allows any syntactic structure that is representable as a tree (without, by definition, any crossing "branches"). Categorical content is not inherently specifiable in any node of the tree. A completely interpreted sentence will, however, have categorical content in its nodes -- it gets to be there by lexical insertion and the operation of the "labelling" rules. The primary categorical content of a syntactic tree in Warlpiri is in the lexical category of the items dominated by the terminal nodes: the terminal node dominating a verb is labelled with the category label corresponding to verb, etc. The labelling rules then specify how a mother node is to be labelled for categorical content, given the labelling of its daughter nodes (cf. Hale, 1980:185-86, summarising current work by Farmer; and Simpson, 1980).

### 5.3 CATEGORIAL SIGNATURES

The category of a (complex) word is a consequence of the word-formation rules which combine the roots and affixes (in Warlpiri, all are suffixes) which comprise the word. When CASE, ARG, COMP are present in the morphological structure of a word, the "category" of the word they go to compose not simply the outer-most category label: the word, for syntactic purposes, has to display more than one category label. Hale, 1979:26 (and n16) has coined the term "categorical signature" for this label. For instance, the word

(2) maliki-patu-rlu  
dog-Plural-Erg

has the "categorical signature",

(3) N-  $\left[ \begin{array}{c} \text{NUM} \\ -\text{sg} \\ +\text{pl} \end{array} \right] - \text{ARG}(\text{ERG}),$

which will also be read as instance of the signature

N - NUM - ARG, and N - ARG.

Thus, a categorial signature displays the syntactically-relevant parts of the morphological make-up of the word, bearing that signature. In general, the categorial signature ignores derivational affixes (stem-forming affixes), and enclitics, and displays just the content of the inflexional affixes (CASE, COMP, ARG). I will here present the categorial signature as an ordered string of categories (from 2.1) with the order paralleling the order of the morphemes in the complex word. Hence, a categorial signature will always begin with one of the free (in traditional sense) categories: N, V, INF, AUX, or M-PART. If it begins with ("is based on") N or INF, it continues with a selection of the derived categories: COMP, CASE, ARG in the order that they occur in the inflected word. Formally, the categorial signature is a projection of syntactically relevant information from the complex word.

There are some suffixes with both derivational and inflexional properties. These "derivational cases" are given contexts  $]_N-]_N$  and  $]_N-]_{CASE}$ , and are listed in 2.3.1.1. These suffixes may form N stems, which are further inflected with CASE and/or ARG suffixes, or they may form CASE expressions (in which case they cannot be followed by derivational affix or another CASE). The rules for translating morphological make-up into categorial signature will make this distinction, for these rules cannot analyse a nominal expression into having more than one semantic case.

Thus wangu in

yapa-kari-kirlangu-wangu  
 person-other-Poss-Priv

may be analysed as a case to give the signature N-CASE(PRIV) for this expression, but kirlangu cannot be so analysed in this expression, because a CASE follows. Thus the expression has two possible morphological structures:

$[[[[yapa]_N kari]_N kirlangu]_N wangu]_N$   
 $[[[[yapa]_N kari]_N kirlangu]_N wangu]_{CASE}$

See the context frames of the suffixes involved, in 2.3.1-2.

There is another respect in which the categorial signature of a word can deviate from its morphological make-up, albeit a minor one.

The 1st and 2nd person singular (free) pronouns, ngaju(lu) and

nyuntu(lu) respectively, are the only Nominals in Warlpiri which optionally inflect with the Ergative. To rephrase this behaviour in the terminology used here, we observe that these two pronouns have the option of two categorial signatures: N, and N - ERG even when in their bare citation, form.

Similarly, demonstrative determiners may be used, without inflexion, as locatives -- these are: nyampu 'this, here', yalumpu 'that (near you), there (near you)', yali 'that (removed), there (removed)', yinya 'that beyond, there beyond', mirni, mirnimpa, yalarni, yalarnimpi. Other spatial expressions also have this property: the cardinal directions, and expressions such as kulkurru 'midway', parrparda 'beyond, far', kamparra 'ahead', purdangirli 'behind' (cf. the list in 6.3). These items all have the option of the categorial signature N - CASE(LOC).

The category of number plays a special role in categorial signatures, akin to that played by the "derivational cases", with which they are listed in 2.3.1.1. Number suffixes have their counterparts in the four numerical determiners, as displayed in the following chart (4):

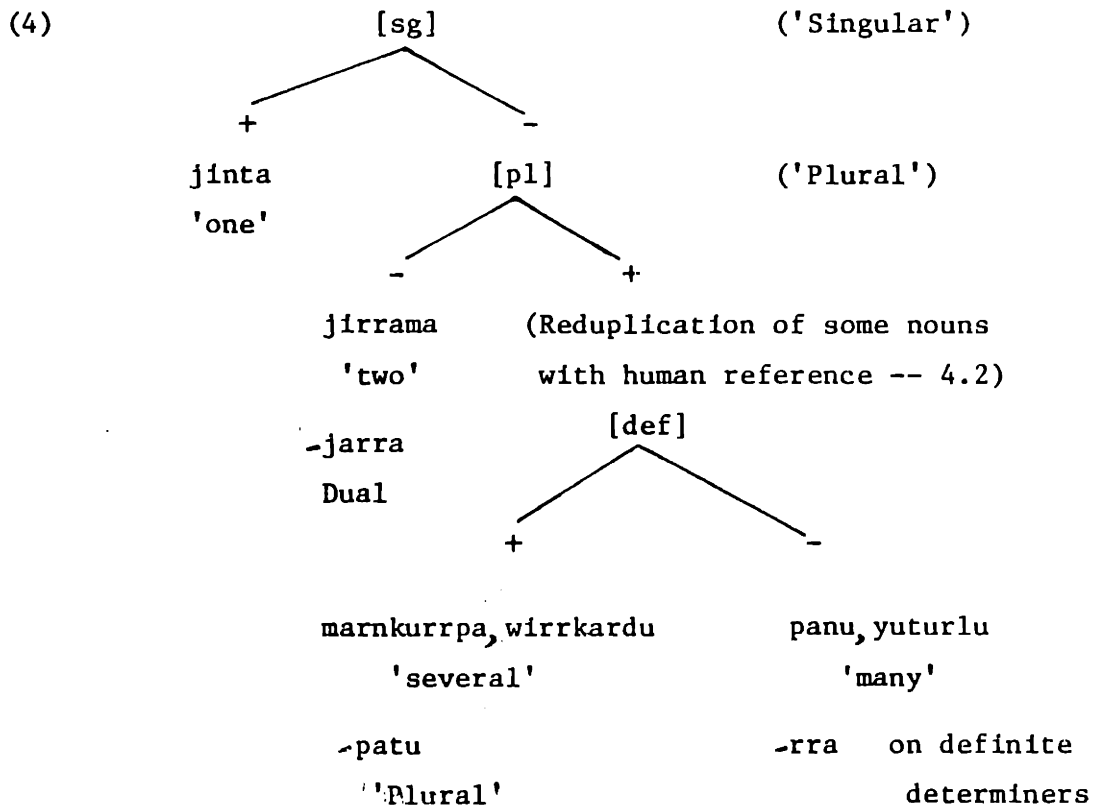

(cf. Hale, 1973a, 1975).

The numerical determiners may project a categorial signature including their number specification, because a number specification is inherent in their meaning. That the categorial signature of, say, marnkurrpa, must include the category NUM[-sg,+pl,+def] is seen from examples such as:

- (5) Yali-patu-rlu    marnkurrpa-rlu kapi-li-nyarra pi-yi    nyurrula.  
       that-Plural-Erg    several-Erg    Fut-333-222    hit-NPast you Pl  
       'Those three are going to hit you (pl.).' (Hale,1966:28)

In (5), the signature of yali-patu-rlu is N-NUM-ERG, and must be contained in that of marnkurrpa-rlu so that there is a single expression preceding the Auxiliary.

#### 5.4 "LABELLING" RULES

I have proposed (5.2) that the one PS-rule of Warlpiri,  $X \rightarrow X^*$ , provides a tree structure with no categorial content at any node. Such a structure passes to lexical insertion, and each lexical item inserted provides categorial content at the terminal nodes: this is the categorial signature (5.3) of each terminal node.

This section sets forth the rules (referred to in section 5.2) which specify how non-terminal nodes may receive categorial signatures (given the labellings of their daughter nodes). In general, node labels will have the same general form whether they are terminal or non-terminal, viz. that of the "categorial signature" already described. From now on that term may be used to refer to the label of a non-terminal node, as well as that of a terminal node (i.e. word).

Labelling rules are like phrase-structure rules "in reverse". The major difference, in this account, is that there are no "bar-levels", governing the degree of recursion the rules may exhibit. The notion employed here that is equivalent to "maximal projection" of a category X is "X which is an immediate daughter of a sentence".

Some reasons for having non-terminal syntactic nodes might be reviewed at this stage. There are "continuous expressions", which have special properties: (i) an inflexion may have "scope" beyond the word to which it is suffixed (if it is a suffix on N, INF, CASE, COMP); (ii) the Auxiliary complex may follow one sentence-initial unit of this type. These two properties correspond very closely to the notion "semantic unit", but



there may be certain units that would seem semantically justified, but which are not valid pre-Auxiliary expressions. (For instance, a putative "verb phrase" consisting of a verb and its object nominal, does not constitute a unit for properties (i), (ii) just mentioned.)

#### 5.4.1 LABELLING OF COMPLEX NOMINALS

Assume that the phrase-structure rule has produced the structure



to which lexical insertion has applied to give:

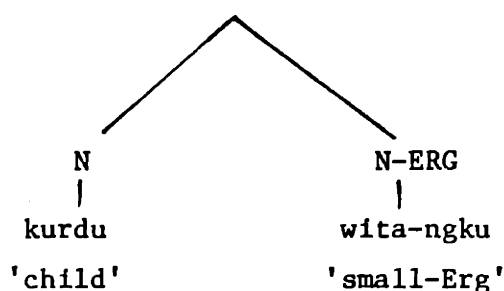

(showing the categorial signature of each word projected on to the terminal nodes of the tree.)

At this point, the structural description of the following rule is satisfied:

#### (6) Complex nominal labelling

Let  $n_1$  be a terminal node, with categorial signature based on N. If  $n_1$  is the right-daughter of  $n_2$ , then the categorial signature of  $n_2$  is identical to the categorial signature of  $n_1$ . I.e.,

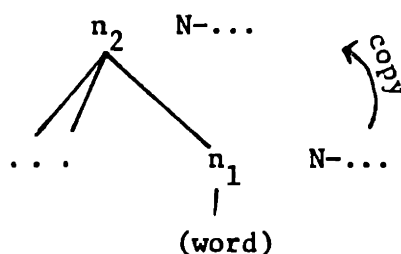

The rule (6) may apply to give the following labelled structure:

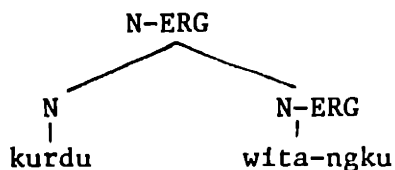

It appears that the restriction of  $n_1$  (in the statement of (6)) to be a terminal node, i.e. a word, may be relaxed with certain categorial signatures. In fact, the restriction may be pertinent only when the signature is N-ARG (i.e. a nominal marked with no case except Ergative or Dative). Thus the following structure is apparently well-formed, (even as a pre-AUX unit):

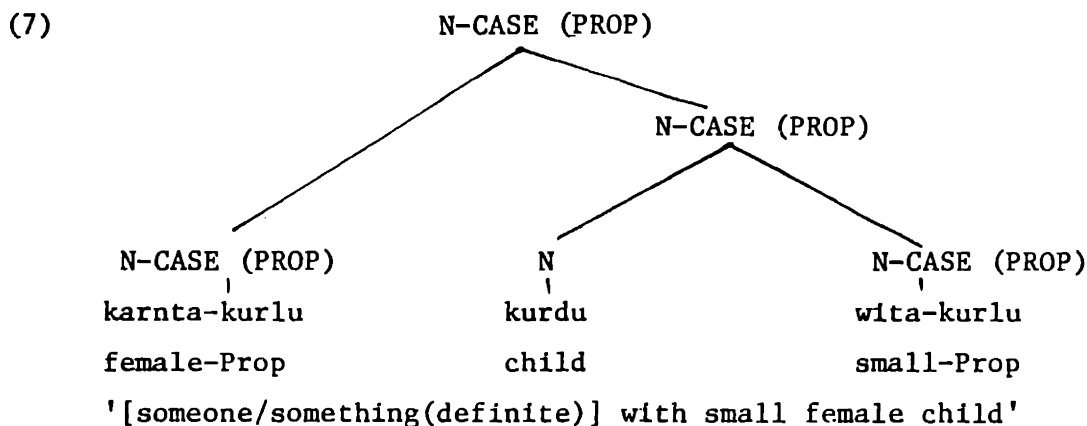

On the other hand, the following structure is not possible:

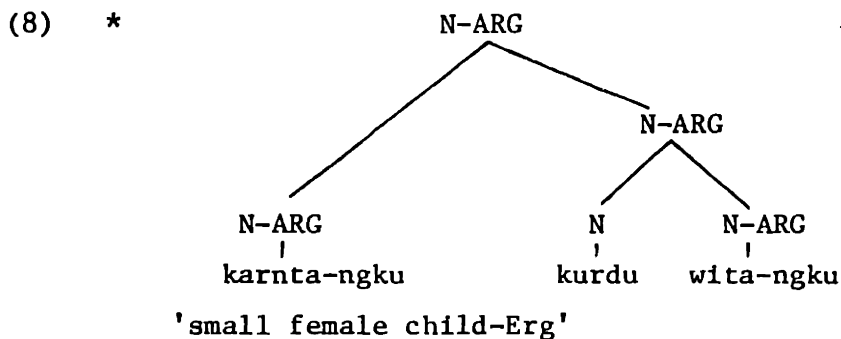

The expression karnta-ngku kurdu wita-ngku can be assigned the given reading only by application of the rule of Merger (7.2), which would apply to the two syntactic units:

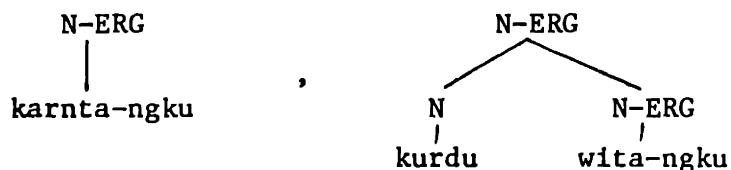

However, the composite expression is semantically assigned, and thus does not allow the Auxiliary to be placed following it -- AUX-placement requires a preceding syntactic unit. In this respect, the account of possible constituents differs empirically from that of Hale, 1979:47.

There are other structures to which (8) may apply (since its structural description is met) but which give rise to ill-formed outputs. These are characterised by the following well-formedness condition, (9), which filters the output of the labelling rules:

(9) Well-formedness condition (Spreading Filter for N's)

Let  $n_1$  be a (non-terminal) node with categorial signature based on N, that has been labelled by (6). If  $n_2, n_3$  are adjacent sister nodes immediately followed by  $n_3$  then the categorial signature label of  $n_3$  must imply the categorial signature label of  $n_2$ .

I.e.

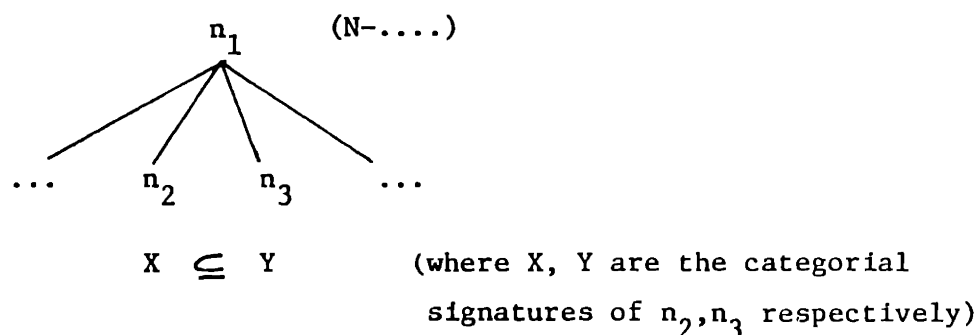

These two principles, (6) and (9), operate to give the result parallel to that of the rule of Incorporation proposed by Hale, 1979:27 (as an operation in logical form, i.e. in initial stages of semantic interpretation), which states:

Bracket together with a nominally based word  $N'$  any immediately preceding nominally based expression  $N''$  whose categorial signature is contained in that of  $N'$  (removing, in the process, the labelled brackets around  $N''$ ).

The example (5) already given shows the similarities, as does (10) following. This output structure is ill-formed:

(10) \*

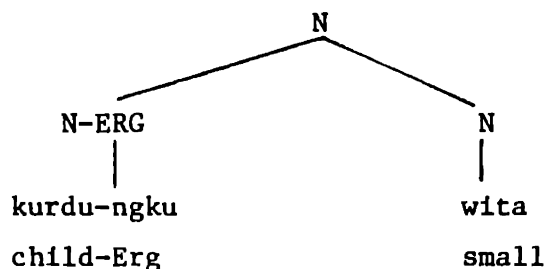

since "N" does not imply "N-ERG"; equivalently, "N-ERG" has content not

deducible from the content of "N", it has extra content, the additional category information of ARG(ERG). Thus the well-formedness condition (9) does the work of the condition of "Containment" formulated by Hale, 1979:28 as a constraint on the operation of the rule of "Incorporation" (the equivalent of my (6)).

Consider now the expression (11), parallel to (8):

(11) kurdu-ngku wita nyampu-rlu  
 child-Erg small this-Erg

If this were inserted into a structure (12), the structural description of (6) would be satisfied, and (13) would be the output.

(12)



(13) \*

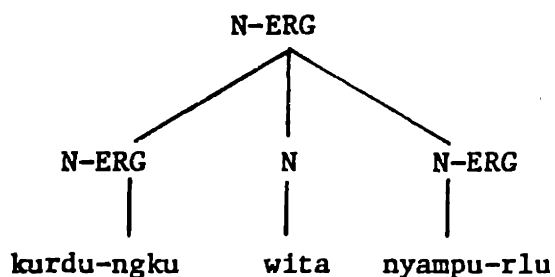

But this violates (9): the left-daughter, kurdu-ngku, has an immediate sister to the right, wita, with a categorial signature "N" which fails to imply the categorial signature "N-ERG" of kurdu-ngku.

If (11) were the terminal string of a right-branching structure, it would be ill-formed, exactly as (8) is ill-formed. Similarly, (11) cannot be the terminal string of a left-branching structure, as (14):

(14) \*

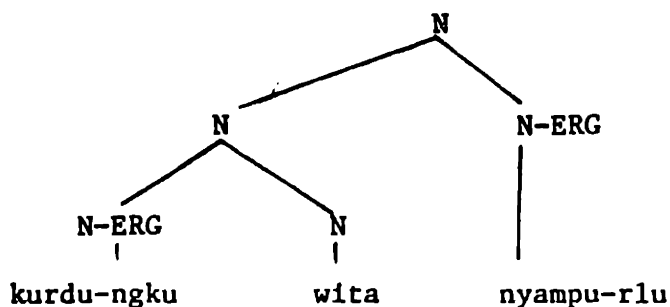

since the categorial signature of kurdu-ngku is not implied by that of wita.

The conclusion is that (11) cannot be the terminal string under a single (non-terminal) node, i.e., it cannot be a constituent. The same would be true if the Ergative case were replaced by Dative or a Case suffix that figures similarly in the categorial signature of a nominal. It is this fact, that a string such as (11) cannot be a single syntactic expression, that partly motivates the details of the formulation of (6) above.

A string that has a well-formed left-branching structure is (15):

(15) kurdu wita-ngku nyampu-rlu  
 child small-Erg this-Erg

After two applications of (6), the structure (16) results:

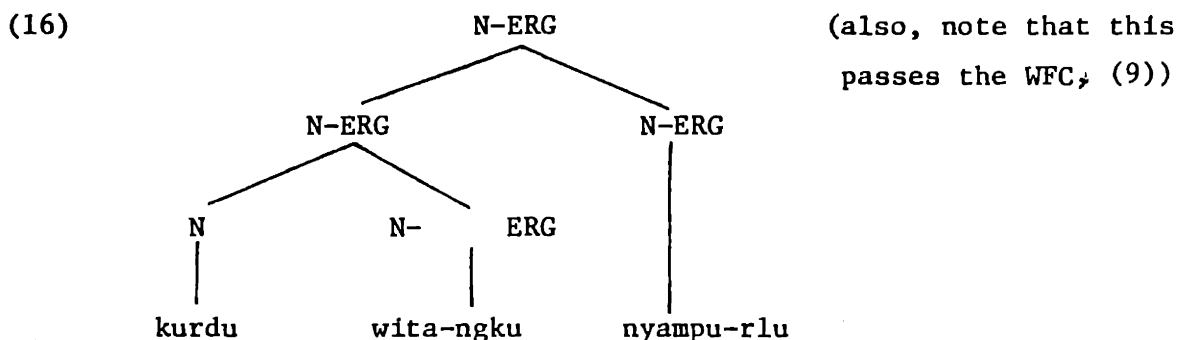

In Hale's parallel treatment of such an expression as (15), the second application of Incorporation would produce an expression like:

{kurdu wita-ngku nyampu-rlu} N, ERG

which differs from (16) essentially in the extra operation mentioned in Hale's statement of Incorporation (see the quotation above), viz. the erasure of internal bracketing around the "intermediate" expression kurdu wita-ngku.

The expression (15) could also be the terminal string of the structure (17), which satisfies (9):

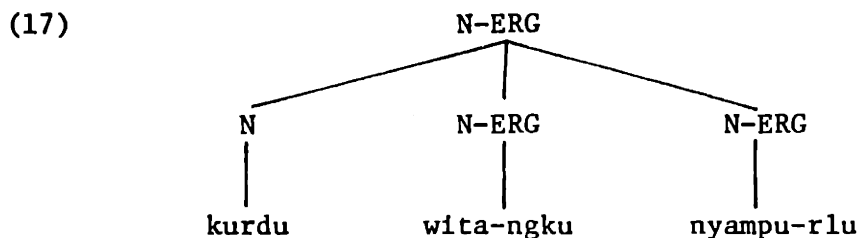

## 5.4.1.1 NUMBER

Examples involving the number suffixes (jarra 'Dual', patu 'Plural' -- see 2.3.1.1) are taken from Hale, 1979:28. I show here just the output structures:

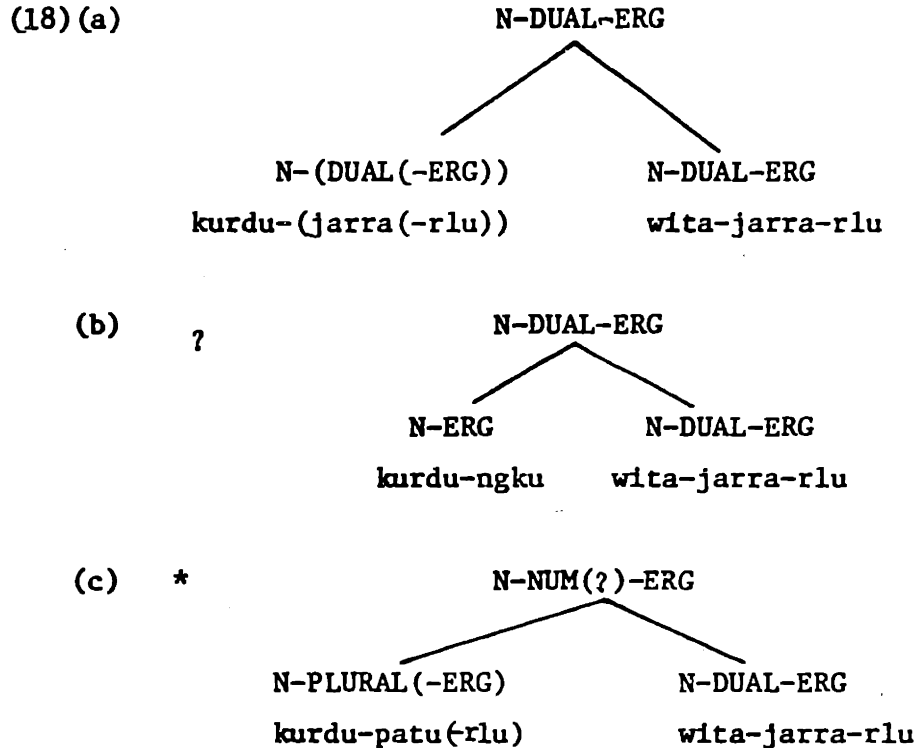

Note that (18)(c) is the sole ill-formed structure, according to (9) -- it has a clash of number features between the right- and the left-daughter nodes. On the other hand (18)(b) is well-formed; whereas by Hale's rule (18)(b) (his (30')(a)) is ill-formed. There may be a difference among speakers of Warlpiri as to the grammaticality of a unit such as (18)(b), and in the event that it is to be ruled out, the well-formedness condition would have to be strengthened. Note however that the following structure is well-formed, (since the expression (19) is observed (as a possible pre-AUX unit):

(19) kurdu-ngku jirrama-rlu  
 child-Erg two-Erg

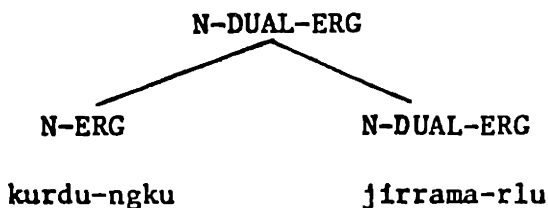

Given that the number suffix is indeed represented in the categorial signature, and that jirrama is inherently dual (cf. 5.3), then (19) is a well-formed structure which is just that of (18)(b). Hence we would expect (18)(b) and (19) to be either both good, or both bad.

#### 5.4.1.2 DOUBLE CASE MARKING

Double case marking is an important syntactic device in Warlpiri. It receives a similar treatment to other elements of the categorial signature, provided the double-case markings are considered as a unit for the application of Labelling Rule (6) and Spreading Filter (9).

By double case marking, I mean an expression of the form:

$$[[[X]_N^Y]_{\text{CASE}}^Z]_{\text{ARG}}$$

where Y has the frame  $]_N^-]_{\text{CASE}}$ , but does not also have the frame  $]_N^-]_N^2$ . (Thus Y is not a "derivational case" (2.3.1.1), but one of the spatial cases, 2.3.2). The function of the Argument marking is to relate the expression  $[[X]_N^Y]_{\text{CASE}}$  to the predicate argument position bearing the matching Argument "case label" (ERG or DAT). (This is a type of "control" discussed in 7.3). Thus, the "inner" CASE on a double case marked expression could not itself be used in the construal rule of Evaluation. (This situation could conceivably arise but does not, in fact, with predicate argument positions linked with a "semantic" case -- see 6.2.2)

Consider the distinction made between the possible single expressions (20) and the strings (21) which cannot be single syntactic expressions:

- (20) pirli yali-rla-rlu                   : may be one expression  
       rock that-Loc-Erg
- pirli-ngka-rlu yali-rla-rlu  
       rock-Loc-Erg that-Loc-Erg
- (21) pirli-ngka yali-rla-rlu           : must be two expressions  
       rock-Loc that-Loc-Erg

---

<sup>2</sup>Parallel to double case marking is the marking of certain complementisers with Ergative or Dative:

$$[[[X]_{\text{INF}}^Y]_{\text{COMP}}^Z]_{\text{ARG}} \cdot$$

There are no complementiser equivalents of "derivational cases".

pirli-ngki yali-rla-rlu  
 rock-Erg that-Loc-Erg  
 pirli-ngka-rlu yali-rla  
 pirli-ngka-rlu yali

The correct distinction is made provided the two cases, here LOC-ERG, are taken as an indivisible unit of the categorial signature; i.e, it is true for satisfaction of (9), that N-LOC-ERG "implies" N-LOC or N-ERG, but LOC-ERG may imply only the combination LOC-ERG, or simply N.

The question arises as to the well-formedness of an expression such as:

(22) pirli-ngka-rlu yali-rlu  
 rock-Loc-Erg that-Erg

There is a confusing factor here viz. the optional categorial signature N-LOC available for yali 'that', which possibly allows (22) to be well-formed. However, yali, etc., are generally used as a Locative only without further inflexion (other than enclitics), and it is quite likely that yali-rlu can have only the categorial signature N-ERG (thus rendering (22) ill-formed as a single expression), and cannot have the categorial signature N-LOC-ERG.

#### 5.4.1.3 CO-ORDINATION

Another way of producing complex nominal expressions is by co-ordination, as exemplified in the following two sentences:

(23) (a) Karnta-ngku manungarrka-ngku-pala kurdu nya-ngu.  
 woman-Erg and man-Erg-Aux-33 child see-Past

(b) Karnta-ngku C ngarrka-ngku-pala kurdu nya-ngu.

'The woman and the man saw the child.'

(where "C" is used, following Hale, 1973a:342, to represent an intonational pattern characteristic of nominal co-ordination.) A special labelling rule is required for nominal co-ordinate constructions, though I do not formulate it here.

Hale, 1973a:323 gave principles for determining the person and number features of a co-ordinate nominal expression, on the basis of the



value of those features for the co-ordinands, As for inflexions, the correct generalisation may be that

co-ordinated nominals must agree in Argument marking.

Hence the following would be possible single co-ordinated expressions:

- (24)(a) Karnta-ngku manu ngarrka-ngku  
 woman-Erg and man-Erg
- (b) pirli-ngka-rlu manu manangkarra-rla-rlu  
 rock plain
- (c) ngarrka-ku manu karnta-ku  
 -Dat -Dat
- (d) yurdi-ngirli manu ngapa-kurra  
 tree top-Elat water-All

as well as counterparts of each of these with "C" co-ordination intonation (I am not as sure of the well-formedness of (24)(d) as of (a)-(c)). On the other hand, (25) could not be single expressions (even if manu is replaced by "C"):

- (25)(a) karnta-ngku manu ngarrka-ku  
 -Erg -Dat
- (b) karnta manu ngarrka-ngku  
 -Erg
- (c) yurdi manu pirli-ngirli  
 tree top rock-Elative

Unlike the situation of incorporated nominal expressions, as produced by (6), an unmarked nominal (as karnta in (25)(b), and yurdi in (25)(c)) cannot be included in the scope of a marked nominal to its right.

Note that (9) does not apply to co-ordinated structures: (i) the person and number features of the co-ordinate (mother) node do not necessarily match those of each of the daughters, but rather represent their logical sum; (ii) distinct semantic cases may be conjoined (though this is currently underdetermined by the data). This is one reason why (9) is formulated to check specifically the output of (6).

## 5.4.2 COMPLEX COMPLEMENTS

This section considers syntactic units consisting of a [+N] word (an Infinitive, or certain nominals -- see 6.3) together with its arguments, or other dependent expressions.

## 5.4.2.1 INFINITIVE COMPLEMENTS

Warlpiri employs a variety of infinitive complements for the expression of complex propositions -- see 2.3.3, 7.3.2. Such complements show similar behaviour to complex nominals in the ability of the complementiser marking on the Infinitive to extend its scope leftward to encompass other words of the complement. Furthermore, infinitive and dependent words may act as a pre-Auxiliary unit (provided the Infinitive is the final word of the complement expression). For example, the following sentence shows a two-word infinitival complement in pre-Auxiliary position:

- (26) Karli jarnti-rni-nja-rla-jinta-rna-ju pantu-rnu.  
 bmg trim-Inf-Refl Prox Comp- I -me pierce-Past  
 'I cut myself (accidentally) while trimming the boomerang.'  
 (Hale, 1979:7)

Thus the following labelling rule is required:

- (27) Infinitival Complement labelling:

Let  $n_1$  be a terminal node with categorial signature based on INF. If  $n_1$  is the right-most daughter of  $n_2$ , then  $n_2$  may be given the categorial signature of  $n_1$ .  
 I.e.

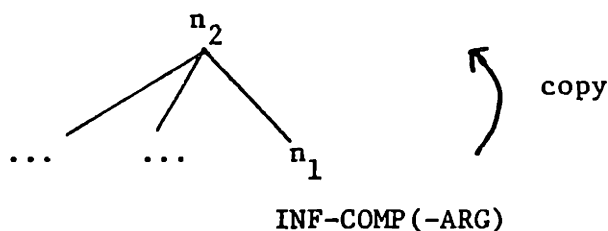

Rule (27) corresponds to Hale's, 1979:43 rule of Infinitival Bracketing. As an example, consider the infinitival complement in (26), which, after insertion into an appropriate tree and projection of categorial signatures, has the structure (28):

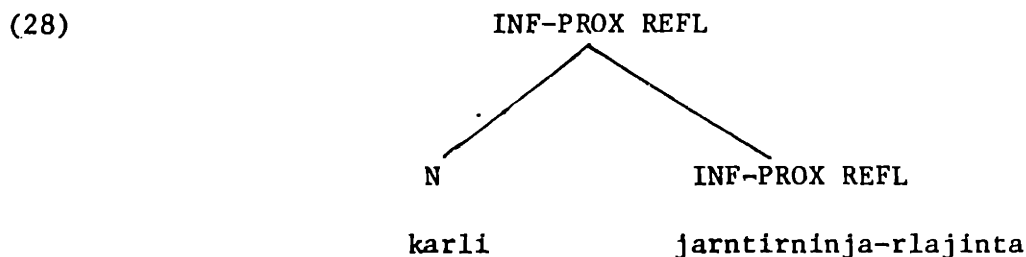

The operation fo (27) is not really governed by an equivalent of the Spreading Filter for N's, (9)<sup>3</sup>. Instead, any "spread" complementiser is ignored in semantic interpretation. Thus, the well-formed (29) is synonymous with (26):

(29) Karli-ngka-jinta jarnti-rni-nja-rla-jinta-rna-ju pantu-rnu.  
 bmg-Prox Refl trim-Inf-Prof Refl-I-me pierce-Past  
 'I cut myself (accidentally) while trimming the boomerang.'  
 (ventured by Hale, 1979:63n7; and subsequently approved by  
 speakers at Yuendumu.)

Rule (27) provides the pre-Auxiliary unit (30), parallel to (28):

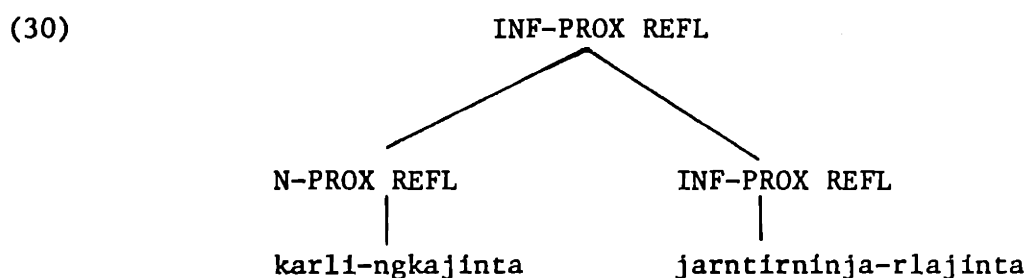

Both (28) and (30) receive the same semantic interpretation, which may be symbolised as

{karli, jarntirninja} -rlajinta

Cf. the semantic expressions produced by Complement Merger, 7.2 (9)(a). Compare the possible Infinitival Complement structure (31), and its interpretation (32):

<sup>3</sup>I am grateful to Joan Bresnan for discussing these matters with me, and for encouraging me to abandon attempts to further amalgamate (too closely, I now believe) (27) and (6), and rather to bring out parallels between complements headed by Infinitives and Nominals. Note that Hale's Infinitival Bracketing is quite different from his Incorporation, in not being subject to "Containment".

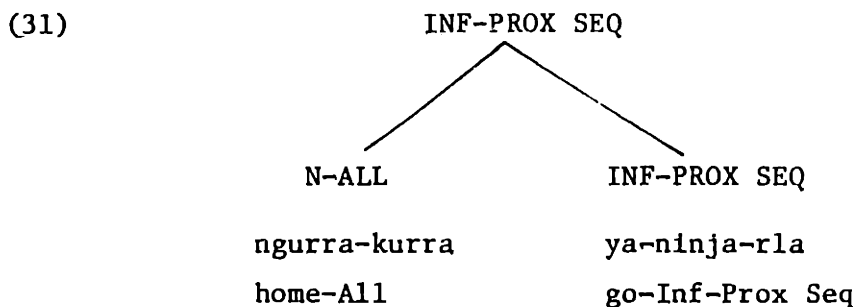

(32) {ngurra-kurra yaninja} -rla 'having gone home'

#### 5.4.2.2 NOMINAL COMPLEMENTS

Consider the following textual example of a CASE "spread" over a nominal and a complement: (transcribed and brought to my attention by Laughren)

Ngaju-ku-pirdangka-kurlangu-kurlu kurdu-kurlu.  
 I-Dat-same gen. kinsman-Poss-Prop child-Prop  
 'with my sister's child' (George Jampijinpa, Kinship remarks, 1980)

The structure involved is (33), with semantic interpretation (34):

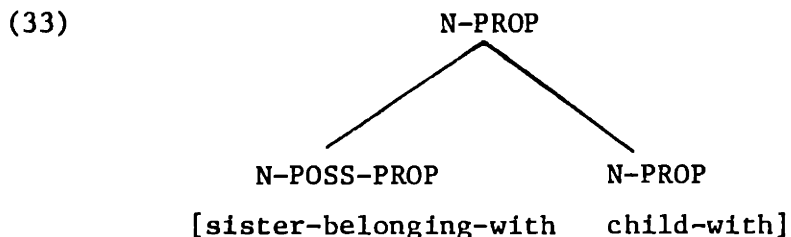

(34) {ngaju-ku-pirdangka-kurlangu kurdu} -kurlu

The process involved in deriving (34) involves two processes, including one, considered below, which is quite similar to that involved in deriving an infinitival reading such as (32). The "outer" labelling of (33) is given by Complex Nominal Labelling, (6). Therefore, (33) is subject to (9), the Spreading Filter, which it would fail, since the signature N-POSS-PROP is not implied by N-PROP. How then is (33) to be derived?

It is relevant here to note that ]kurlangu]<sub>N,CASE</sub> is doubly classified, as a "derivational case" (2.3.1.1) -- a fact, indeed, which allows the formation of a word with ]kurlu]<sub>N,CASE</sub> following it. Thus, the categorial signature of ngajukupirdangka-kurlangu is allowed to be N, as well as N-POSS, and is taken as N for the application of the Spreading

Filter, (9). The Possessive suffix is taken into account only for working out the relation between ngajukupirdangka and kurdu in (34).

Similar "bivalence" is exhibited in nominal complement expressions, such as (35), from 6.3.2 (25):

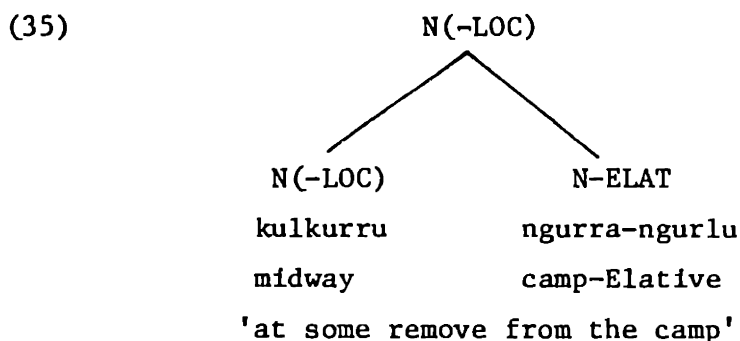

(The nominal kulkurru is one with an "inherent" Locative -- see 5.3).

The labelling of the non-terminal node of (35) is not done by Complex Nominal Labelling, (9). Such constructions are similar to (32), in that they include a word bearing a case which is used to relate expressions solely within the complex expression. An important difference from Infinitival Complement Labelling is that there is no ordering requirement on the "head" (kulkurru in (35) could also occur after ngurra-ngurlu; just as kurdu occurs finally in (33)).

The following labelling rule comes close to what is required:

(36) Nominal Complement labelling:

Let  $n_1$  be a terminal node with categorial signature based on N. If  $n_1$  is the daughter of  $n_2$ , then  $n_2$  may be given the categorial signature of  $n_1$ .

By application of (36), then, with  $n_1$  the node of kulkurru, the structure (35) is derived. The same rule, (36), could derive (37), which is to be compared with (33). The operation of (36), at least in structures like (33) to which Complex Nominal Labelling, (9), also applies, is connected with the double classification of the "derivational cases", and calls for further study. In simpler instances, not involving rule (9), rule (36) apparently does produce genuine pre-Auxiliary units, as attested for instance in 6.3.2 (23).

#### 5.4.3 SENTENCES

A further labelling rule is needed to provide a label for the root

node of a sentence:

(37) Sentence formation;

If  $n_1$  immediately dominates  $n_2$ , and  $n_2$  has categorial signature based on V, then the categorial signature of  $n_1$  is based on V.

Warlpiri allows sentences such as (38):

(38)(a) Ngarrka-jarra-pala wiri-jarra.

man -Dual -33 big-Dual

(b) Ngarrka-jarra wiri-jarra.

'The two men are big.'

Unlike in verbal sentences, the presence of a person/number marking clitic sequence is optional in nominal sentences.

Used predicatively in this manner (or as a Predicational Adjunct (7.3.3)), one nominal does not have to agree in number with the other nominal with which it goes to form the expression. Thus, (38)(c) is another (in fact, preferred) way of saying (38)(a),(b):

(38)(c) Ngarrka-jarra(-pala) wiri.

man -Dual AUX) big

'The two men are big.'

I propose the following labelling rule:

(39) Nominal sentence labelling:

If  $n_1$  is unlabelled, and dominates a node with categorial signature based on N, but none with categorial signature based on V or INF, then  $n_1$  may be given the categorial signature N.

A distinction<sup>4</sup> is made among sentences, which by rules (37) and (39) are labelled "N" as opposed to "V". The Labelling Rules give "semantic head" of the expression: a finite verb is the "head" of its clause and in a comparable way a predicate nominal is the "head" of a nominal sentence

---

<sup>4</sup>The distinction is not novel — Dixon, 1972:71,205-208 gives "minimal sentences" a syntactic representation wherein the sentence is of the category "NP". And Simpson, 1980:50 assigns [+N,-V] to nominal sentences.

(a sentence lacking a finite verb). An Auxiliary base looks to the governing V for interpretation (7.4), and thus cannot occur in a sentence with root node N. Furthermore, pronominal clitics are optionally<sup>5</sup> in an N-sentence, but obligatory in a V-sentence.

The reader may notice the similarity between (39), and Nominal Complement Labelling, 5.4.2.2 (36). The one important difference is that (39) labels a unit in which there may be an Auxiliary, whereas Nominal complements generally cannot contain Auxiliaries. However, this is not necessarily a barrier to a possible account amalgamating the labelling of Nominal sentences and Nominal complements, but I do not pursue the matter here.

### 5.5 UNLABELLED NODES

Several rules were presented in 5.4 which effect the labelling of non-terminal nodes of the syntactic tree with categorial information (in the form of "categorial signatures"). Within the conception of Warlpiri grammar advanced here, this is the only way a non-terminal node of a tree can come to bear categorial information. Other languages may have PS-rules which contain categorial information, but Warlpiri does not.

There is a general well-formedness condition on S-structure which every language must meet, viz. that in shallow structure, every node must bear some categorial signature. That is, every node (terminal or non-terminal) of phrase-structure after lexical insertion must bear categorial information.

So far as I am aware, this condition has been satisfied by all analyses proposed within generative grammar, irrespective of language. In fact, under the usual conception of phrase-structure rules, it could not fail to be so. The possibility of nodes without categorial information only arises when we investigate the possibility that PS-rules have the possibility in some languages of not introducing categorial content. The extreme case is where the PS-rules introduce neither categorial content

---

<sup>5</sup>In this account, the distinction between obligatory and optional pronominal clitics has to be related instead to the clause of the Evaluation rule providing an interpretation '3rd sg.' in the absence of a pronominal clitic. In a nominal sentence, this clause of the Evaluation rule is optional, whereas in verbal sentences it is obligatory.

nor modifier-head relations, as Hale, 1980:185 brought up. This view is adopted here for Warlpiri, with the result that the operation of what I have called "labelling rules", after lexical insertion into an arbitrary unlabelled tree, is the only source of non-terminal categorial information. Since the labelling rules are optional, and since their structural descriptions do not cover all possible input configurations, it follows that unlabelled nodes are now a possibility, and a principle of a very general nature does not allow structures with unlabelled nodes to undergo the semantic interpretation rules. In particular, a "no unlabelled nodes" condition rules out terminal nodes without category labels. Such a situation could arise in our view of Warlpiri grammar simply by not performing lexical insertion at a given terminal node.

Conversely, there can be no terminal node with a categorial signature and yet with no lexical item dominated by it. This would be possible if there was such a thing as an "empty" lexical item, e.g. a lexical item "[e]<sub>N</sub>" -- something which has never been proposed for any language<sup>6</sup>.

This effectively means that Warlpiri grammar does not make use of "gap"-like entities, indeed, a result supported by all the evidence, as discussed in Hale, 1979:5. This will be true, according to the view of the typological possibilities for the base assumed here, just when the PS-rules of a given language do not specify categorial content.

For roughly the same reasons, we expect that a language with a base component like that proposed here for Warlpiri will necessarily lack Structure-Preserving transformations. Even if the transformational component is seen as applying after lexical insertion (i.e. lexical insertion in deep-structure), which would certainly be a requirement if Warlpiri were to have a transformational component, the possibility of an optional transformation is ruled out by the absence of "gaps", as sketched above. The reason for this is that a movement transformation, as currently conceived by many theorists, requires an "empty node" as the site to which

---

<sup>6</sup>One could, however, add a special labelling rule to Warlpiri, which would provide a specific label for a node that would otherwise remain unlabelled, just as in an orthodox PS-account one may specify that lexical insertion is obligatory at every terminal node. Thus the absence of "gap", while following without specification in a labelling approach to phrase structure, is not a necessary property of it.



a constituent is moved. But an empty node in Warlpiri must also be a node devoid of category information, and hence is ill-formed, and would at least require a putative transformation to be obligatory.

It is interesting to note at this point that Warlpiri apparently lacks another grammatical device familiar to the student of English grammar, namely the "dummy" nominal, such as the "dummy" subject it in structures of extraposition. This is not connected closely with the observation I have just made about the absence of "gaps" in Warlpiri grammar, but may be related through the more restricted nature of the lexical entries for various anaphoric Nominals in Warlpiri. For instance, the possible referent of a pronominal anaphor in Warlpiri (see 7.3 (i)) cannot be a clause, but is restricted to the range of reference that nominals other than anaphors cover. Cf. Jayaseelan, 1979, who argues for a base-generated non-anaphoric pronoun source for "dummy it" in English.

#### 5.6 AUXILIARY PLACEMENT

The Auxiliary is an important and specialised unit in Warlpiri, whose structural properties are detailed in 2.7.1. Of interest in this chapter is the relative ordering of the Auxiliary with respect to the other expressions in a Warlpiri sentence.

Basically, the Auxiliary may occur only in "first" or "second" position in the sentence. (A sentence cannot contain more than one Auxiliary.) A detailed account of Auxiliary placement is provided by Hale, 1973a:311-314. Hale argues there that the Auxiliary is underlyingly sentence-initial, and moves (under certain conditions) into "second position". Furthermore, an optional rule of "left dislocation" may move a constituent of the sentence, after AUX-Insertion has applied (see also the summary of Hale, 1967-1968 in 5.1.3).

In the view adopted in this work, a "left-dislocated" expression is considered to be separate from the following (finite) sentence, and generated "in position". The placement of the Auxiliary is seen as a well-formedness condition, which requires the Auxiliary to be in one of two environments:

- (1) At the beginning of the sentence, or immediately following a major intonational break, characteristic of topicalised expressions - i.e., in "first position".

- (ii) Immediately following a single syntactic constituent which in turn is in "first position" as defined in (i) -- i.e., in "second position".

The Auxiliary may be in "first position" only if it has a "base" which is disyllabic or longer. An Auxiliary of any size may be in "second position", and is intonationally subordinated to the preceding word, if not in fact cliticised to it.

Examples of Auxiliary placement are provided by virtually every sentence of Warlpiri cited in this work. Examples showing a "topicalised" expression, and an Auxiliary in "second position" include 6.3.1 (18), (21).

Note that the sort of conditioning an Auxiliary placement makes it a prime candidate for membership in the "Punctuation" component of the grammar (see 5.2), which makes simultaneous use of phonological and syntactic/semantic representations. (Note also remarks on Auxiliary placement in 2.6.5.)

#### 5.6.1 MODAL PARTICLES

The small category of Modal Particles includes the following words:

(i)	karinganta	'Declarative'
	pangkala	}'Permissive'
	kirli (H)	
	kulanganta	'Present Counterfactual'
	marda	'perhaps'
	kari	'Assertive'
(ii)	japa	'Interrogative'
	nganta	'supposedly'
	mayi	'presumably'
	waja	'Emphatic'

These are included in this section because they occur in positions also favoured by the Auxiliary. Roughly speaking the Modal Particles listed in (i) occur in "first position" or "second position" and possibly sentence-finally; and those in (ii) cannot begin a sentence, and, prefer to be in "second position". Furthermore, kulanganta and marda, at least, may occur elsewhere, with scope over the expression (immediately following and preceding, respectively), rather than over the entire sentence -- see 7.6.3.

A Modal Particle in "second position" may even "force" the Auxiliary to follow it, as in:

Miirnta-jangka mayi ka-mpa kiri-jarri-mi waninja.  
 'flu -Result presumably Pres-you striped-Inch-NPast throat  
 'Presumably your throat is sore from 'flu?'

The Conjunction manu 'and' usually occurs at the beginning of the sentence that it introduces, or between two nominal expressions that it links (5.4.1.3). It also behaves like a Modal Particle in occurring in "second position", as in the following sentence:

Murdukayi-rli ka-lu parnka-nja-rla walya manya-ma-ni,  
 vehicle -Erg Pres-they run-Inf-Seq ground soft-Caus-NPast  
 puluku-rlu manu ka-lu walya manya-ma-ni...  
 bullock-Erg and Pres-they ground soft-Caus-NPast  
 'Vehicles passing are softening the ground, and cattle are  
 softening the ground...' (Hale, 1966:427)

In these last two sentences, furthermore, the Modal Particle or Conjunction, and the following Auxiliary, are able to form an intonational unit together with the first word of the clause, and be subordinated to that first word. Thus the "Punctuation" component unites three syntactic units:

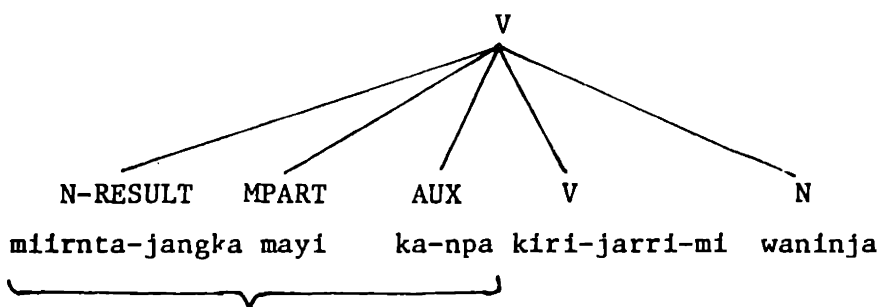

## CHAPTER 6: THE LINKING OF CASE

This chapter sketches the aspects of case linking which are assumed in the rest of the work. Case linking is the association, or alignment, of argument positions in a predicate or, more generally, the functional structure of a sentence, with the various cases.

For the place of the Linking Rules within the grammar, see the diagram in 5.2.

This linking of role and formal case is very largely mediated through the lexical entry of the predicate-word in question: linking rules fill out the content of lexical entries, a fact that makes them, from one point of view, a highly specific form of lexical redundancy rule.

(Ostler, 1979:16)

Hale (1977 lectures, handout "Walbiri II") formulated "tentative rules of alignment" for Warlpiri, using a framework closely related to that of Carter, 1977 -- an approach which has a considerable amount in common with subsequent work by Ostler (Ostler, 1979:59-60)<sup>1</sup>. Hale, 1978 presents the verbs of Warlpiri in "alignment classes" or "case frames"-groupings. I have provided basic information on "case frame" for the roots listed in the Appendix. In this chapter, and the Appendix, I use the "(formal) case labels" ERG, DAT and ABS. The Linking Rules assign these labels to the argument positions of a predicate. The case labels are used in the rule of Evaluation (7.5). Direct Evaluation fills the argument positions of predicates by matching an expression bearing a particular case in its

---

<sup>1</sup>Ostler departs from Carter, and Hale, in at least two respects. Ostler, 1979:120-22 distinguishes between what have been called "grammatical cases" (in Warlpiri, Ergative and Dative, and in some sense, Absolutive) and "semantic cases" (Locative, Allative, Elative, Perlative, Comitative, Propriative, Possessive, ...) in a more precise fashion by distinguishing between "grammatical linking rules" and "semantic linking rules", a distinction not made by Carter, who introduced the term "linking". For instance, the differing usages of the Locative case (as part of the "case frame" of a particular verb, v3. to express a location) are thus distinguishable. "Semantic linking" is not discussed in this work -- see Hale, 1978:55ff. Secondly, Ostler orders argument positions by assigning each of them a role, and using Role Hierarchies, whereas Carter appeals to a "left-to-right" ordering of argument positions.

categorial signature with an argument position bearing a "matching" case label. The following "matchings" hold:

	<u>morphological category</u>	<u>categorial signature</u>	<u>case label</u>
Argument	{	Ergative, ERG	ERG
		Dative, DAT	DAT
Nominal, N			ABS

The case label ABS is different from the others, in that it is matched by "bare" Nominals, ones not bearing a morphologically marked case. To a very limited extent, morphologically unmarked Nominals may match. Conversely, morphologically unmarked Nominals may not be matched with ERG or DAT case labels<sup>2</sup>. By utilising this type of matching, there is no need to recognise the spurious "zero morpheme" of "Absolutive" (morphological) case.

After surveying the data the reader can easily see what work the linking rules of Warlpiri must do. The gross "output pattern" of the grammatical linkings can be summarised in this table of all possible "case frames" of Warlpiri predicates<sup>3</sup>:

Number of arguments	Case Frames occurring
1	(i) ABS
	(ii) ERG
2	(i) ERG - ABS
	(ii) ABS - DAT
	(iii) ERG - DAT
3	ERG - ABS - DAT

All occurring case frames thus conform to the Warlpiri case

<sup>2</sup>There is a quite limited class of Nominals which constitute an exception to this strict correspondence. These Nominals are treated specially in the assignment of categorial signatures -- see 5.3.

<sup>3</sup>The range of verbs associated with each of these case frames is described in Hale, 1978 at pages 23, 29, 34, 40, 44 and 47 respectively.

hierarchy<sup>4</sup>:

(1) ERG - ABS - DAT

Two of the case frames listed in the table are rather special. The ERG frame, 1(ii) in the table, is found with a limited class of verbs, with a likely historical source as ERG - ABS verbs having undergone "object-incorporation" -- see 6.2.1. And the ERG - DAT frame, 2(iii) is found with a limited class of verbs as the basic frame, but with a larger class of verbs as a "derived" frame -- see 6.1.3.

A typical three-argument verb, yi-nyi 'ERG give ABS to DAT', illustrates three regular Linkings between participant roles (thematic roles)<sup>5</sup> and case. The central three-argument verbs are:

verbs of physical transfer depicting the situation in which an agent (represented by the ergative subject) causes some entity (concrete or abstract, expressed by the absolutive 'direct' object) to move to or from a goal or source (represented by the dative 'indirect' object).

(Hale, 1978:47)

In general, Linking occurs "according to the relative positions of roles and cases on their respective hierarchies" (Ostler, 1979:145). Corresponding to the case hierarchy (1) is a thematic hierarchy along the lines of:

(2)	$\left. \begin{array}{l} \text{Agent of} \\ \text{Causation} \end{array} \right\}$	- (Instrument) - Actor - Patient	-Goal - Source - Path
	Perceiver	Percept	

The hierarchy (2) is inspired by Ostler's, 1979:143-44 two Role Hierarchies, which I repeat here in collapsed form<sup>6</sup>:

---

<sup>4</sup>In Ostler's, 1979:145 terminology, this is Warlpiri's "Normal Hierarchy".

<sup>5</sup>See Ostler, 1979:Chapter I, for a survey of the uses of these terms (or equivalents) and the recognition of a thematic hierarchy (or equivalent) by various theorists, including Fillmore, Halliday, Chafe, J.M. Anderson, Gruber, Jackendoff and Carter.

<sup>6</sup>Ostler argues for a hierarchy T-G-S-P for Relational Predicates, and S-P-T-G for Actional Predicates, and some roles have a range not immediately implied by their name -- e.g. Path includes Instrument.



## 6.1 REGULAR LINKING

Building on Ostler's suggestion, I propose the following Linking Rules for Warlpiri, which use the two hierarchies in (3):

(4)(a) Link ERG with Agent of Causation  
or Perceiver

(b) Link ABS with next highest role, providing it outranks Goal

(c) Link DAT with next highest role

Examples illustrating the operation of the various subrules are as follows. The particular assignment of Roles must, of course, be regarded as highly tentative.

<u>Verb</u>	<u>Case Frame</u> <u>participant roles</u>
By rule 4(b) karri-mi	'ABS stand' Actor (Theme?)
By rule 4(b)(c): wangka-mi	'ABS speak (to DAT)' Actor - Goal
japirdi-mi	'ABS threaten DAT (behind back)' Actor - Goal
waraparnpi-mi	'ABS announce, name, or arrival of, DAT' Actor - Theme (Source?)
rdanpa-rni	'ABS accompany DAT' Actor - Theme
yulka-mi	'ABS cherish DAT' Theme? - Source/Goal ?
kapati-mi	'ABS be uneasy in DAT (place, situation)' Theme - Source



VerbCase Frame  
participant roles

By rules (4)(a),(b),(c):

---

kiji-rni	'ERG throw ABS (to DAT)' Agent - Theme - (Goal)
yirra-rni	'ERG place ABS on DAT' Agent - Theme - Goal(?)
parnta-yirra-rni	'ERG put ABS (cover) over DAT' Agent - Theme - Goal (Path?)
payi-rni	'ERG ask ABS (person) about DAT' Agent (Actor?) - Theme (Source?) - Goal (Path?)
wajili-pi-nyi	'ERG chase ABS' Agent - Theme (Patient?)
pura-mi	'ERG follow ABS' Agent (Actor?) - Theme
nga-rni	'ERG ingest ABS' Agent (Actor?) - Theme
marda-rni	'ERG hold, have ABS' Agent - Theme
nya-nyi	'ERG see ABS' Perceiver - Theme/Percept
purda-nya-nyi	'ERG hear, feel ABS' Perceiver - Theme/Percept
kanginy-pi-nyi	'ERG mishear, misunderstand ABS' Perceiver - Theme/Percept

---

By rules (4)(a),(c):

warri-rni	'ERG seek DAT' Agent (Actor?) - Goal
-----------	---

VerbCase Frame  
participant roles

nya-nyi

'ERG look about in search of DAT'  
Agent (Actor?) - Goal

Notice the uniform linking correctly accorded to Verbs formed in productive combination with the Causative and Inchoative (2.6.1):

N-jarri-mi

'ABS become N (with respect to DAT)'  
Theme - (Goal, Source,....)

N-ma-ni

'ERG cause ABS to become N'  
Agent - Theme

The Linking rules (4) assume an independently motivated identification of participant roles, at least to the extent of their relative ordering on the thematic hierarchy, and identification of the roles explicitly referred to in the rules (i.e. Agent of Causation, Perceiver, Goal). The general procedure for analysing predicates raises many long-standing problems, and this work does not address them. Even the determination of a predicate's functional representation<sup>7</sup> is not straightforward. A relevant Warlpiri illustration of one type of problem encountered is provided by the verb:

jija-mi

'DAT exceed ABS,  
DAT defeat ABS,  
ABS succumb to DAT'

I have provided the gloss 'succumb' for jija-mi to indicate how its meaning might be analysed in a way which would provide the required linking to the ABS-DAT case frame. However, the linking exhibited in this predicate is surely not so simply accounted for.

At this point, definitions of certain "grammatical relations" in Warlpiri may be advanced:

(5)(a) The subject of a predicate is the argument position

<sup>7</sup> Functional representation is "a well-formed fragment of functional structure which details some aspects of the word's meaning as well as its inherent arguments". (Ostler, 1979:329)

highest on the thematic hierarchy.

- (b) The object of a predicate is the argument position (of the predicate, not just of the sentence) lowest on the thematic hierarchy.

(cf. Ostler, 1979:147, quoted above). Given the Linking Rules (4), the definitions (5) are virtually equivalent to the arguments defined by the case-disjunctions (a) "ERG else ABS" and (b) "DAT else ABS" of Hale, Jeanne & Platero -- see 2.3.4. There are predicates, however, where the identifications made by the definitions (5) differ from those made by the case-disjunctions -- see 6.1.2, 6.1.4.

#### 6.1.1 DOUBLY-CLASSIFIED VERB ROOTS

There are a couple of verb roots in Warlpiri which appear in both the two case frames ABS and ERG-ABS (Hale, 1978:33-34, 1969:3-4). These are:

janka-mi	}	'1. ABS burn, cook (intrans.);
kampa-mi		2. ERG (source of heat) burn, cook ABS'

(cf. the singly-classified purra-mi 'ERG (person) burn, cook ABS'). The other example is :

warrka-rni	'1. ABS climb, ascend, mount (intrans.);
	2. ERG rides ABS (horse)'

And, the avoidance and respect style verb :

ngarri-jarri-mi	'move, go, come, bring, etc.'
	(used by man for wife's mother)

is "doubly-classified", as ABS, ABS-DAT, and ERG-ABS. The case frame employed is determined by the meaning expressed in a particular use. Such variability applies to the other avoidance-style verbs miti-pi-nyi and marrarl-(y)a-ni.

Further, let us assume, as seems plausible, that the second sense of warrka-rni arose recently, when Warlpiri speakers first encountered horses (and other beasts of burden). Then we have an example of the application of the Linking Rules to a novel functional representation of verb. The more agentive 'climbing' involved in horse-riding compared to usual, actional, climbing has the application of triggered Linking Rule (4) (a).

Consideration of these verbs with "variable" case frames strongly suggests the reality of rules employed by Warlpiri speakers with the effect of the Linking Rules. An explanation could hardly be based on an account content to merely list case frames in a verb's lexical entry.

### 6.1.2 COGNATE OBJECT CONSTRUCTIONS

A construction of limited occurrence not strictly covered in the above discussion is the "cognate object" construction as in:

- (6) Warlpiri ka-rna ngajulu wangka-mi.  
           Pres-I    I            speak-NPast  
           'I am speaking Warlpiri.'

This sentence involves the verb wangka-mi 'ABS speak (to DAT)'. But in this construction it appears to have a two-place functional structure which after linking allows the reading 'ABS (person) speak ABS (language)'. We might hope that this linking would follow from the general Linking Rules, given the appropriate two-place functional structure, even though an ABS-ABS case frame is found in no other context in Warlpiri.

The properties of the cognate-object construction in five Pama-Nyungan languages are surveyed in Austin, 1979. He finds that in all five languages the verb 'talk' allows a cognate object specifying the language spoken. Commonly recurring cognate object constructions in other languages are 'ABS lie in sleep(ABS)', 'ABS go for walk(ABS)', which in Warlpiri are amalgamated into the Preverb-Verb combinations. The Preverb possibility also appears to exist for wangka-mi, as an alternant of (6) is:

- (7) Warlpiri-wangka-mi ka-rna ngajulu.  
           speak-NPast Pres-I    I  
           (same meaning as (6))

The placement of the Auxiliary ka-rna would be ungrammatical unless Warlpiri in (7) were taken as a Preverb in combination with wangka-mi -- cf. 2.6.5. The Preverb and the cognate-object pattern apparently may co-occur, as attested in:

- (8) Warlpiri-wangka-mi ka-rna yimi.  
           speak-NPast Pres-I message, speech  
           'I am telling a story in Warlpiri.'

Note that the argument corresponding to the argument of the one-

place verb is the one which is construed with the subject pronominal clitic in the Auxiliary:

(9) Warlpiri ka-rlipa wangka-mi ngalipa.

Pres-122 speak-NPast we incl. pl.

'We are speaking Warlpiri.'

Ngajulu ka-rna wangka-mi Warlpiri manu Warlmanpa.

I Pres-I speak-NPast and (language name)

'I am speaking Warlpiri and Warlmanpa.'

Ngajulu ka-rna-palangu wangka-mi Warlpiri manu Warlmanpa.

I Pres-I-33 speak-NPast

would mean

'I am speaking Warlpiri and Warlmanpa for/to the two (people).'

Another cognate object pattern may be discernible in ngarri-rni used as follows:

(10) Ngarnangarna-nya ka-rna-lu ngarri-rni marluri-ji.

claypans-Top? Pres-we call-NPast claypan-Top

'Ngarnangarna we call claypan(s).'

 (Hale, 1966:465)

### 6.1.3 THE ERG-DAT CONSTRUCTION

The case frame ERG-DAT has a special status. As well as arising in connexion with "verbs of seeking" by Linking rules (4)(a),(c), it occurs as a diathetical<sup>8</sup> variant of certain otherwise ERG-ABS verbs -- those involving both motion and affect, as well as an agent, in their meaning.

The "verbs of seeking" which always are aligned with ERG-DAT are warri-rni 'ERG seek DAT' (the only root verb with only this frame), and ones formed by the addition of the preverb wapal 'in search of', as:

wapal-nya-nyi	'ERG look around in search of DAT'
wapal-karla-mi	'ERG dig in search of DAT (e.g., yams)'
wapal-pangi-rni	'ERG dig in search of DAT (e.g., water)'

<sup>8</sup>A "diathetical rule" (Ostler, 1979:176-77) modifies the lexical entry of a predicate word, and may affect the word's morphology, subcategorisation, functional representation and linking specification (if any). But for perhaps not referring to grammatical relations, this rule type corresponds to Bresnan's "lexical rule".

The frame may also occur with these roots in the absence of wapal.

It is a reasonable extension of the Linking Rules to amalgamate the occurrence of the ERG-DAT case-frame with these "verbs of seeking" with another type of occurrence now to be described.

Certain verbs which are aligned with the ERG-ABS case frame may also occur with an ERG-DAT case frame:

The construction is evidently limited to verbs whose semantic structure is "bi-partite" in the sense that the effect caused by the agent is brought about by causing an instrument (stick, hand, missile, or the like) to move against the entity denoted by the object. It is possible that the ERG-DAT array (together with the special registration in the auxiliary) is used to give prominence to the motional portion of the verbal meaning and to suppress the affective portion. This would be consistent with the use of the dative case elsewhere to indicate the goal of motion, as in the ABS-DAT use of the motion verb *ya-ni* 'ABS go, ABS go to DAT (as to visit)', and in verbs of physical transfer and giving.

(Hale, 1978:47)

An example (from Granites, 1976:2) is:

(11)(a) *Watingki marlu luwa-rnu*  
           *man-Erg 'roo shoot-Past*  
           *'The man shot the kangaroo.'*

(b) *Watingki-rla-jinta marlu-ku luwa-rnu.*  
       *'The man shot at the kangaroo.'*

where the extra material in (11)(b) is underlined.

The nature of the extra registration in the Auxiliary is discussed by Hale, 1973a:335-38. Basically, the rla corresponds to the 3rd person Dative argument, here evaluated by the Dative noun ma.lu-ku, as it would in other constructions with a 3rd person Dative. The jinta registers the special semantic effect of this particular construction. Hale, 1973a:336-8 argues that jinta here is abstractly identical to rla, and that a rule of form has the effect of obligatorily converting a sequence rla-rla to rla-jinta. His reason is, in part, that with a non-third person object,

the special registration is marked by rla, as in:

- (12)(a) Kurdu-ngku ka-ju ngaju paka-rni,  
'The child is striking me.'
- (b) Kurdu-ngku ka-ju-rla ngaju-ku paka-rni.  
'The child is striking at me.'
- (c) Kurdu-ngku ka-ju-rla-jinta ngaju-ku paka-rni.  
(equivalent to (b))

Some speakers used version (12)(c) in preference to (12)(b).

The jinta signals this special construction by virtue of being construed with the Dative argument position, the same argument position that rla is construed with, by the regular operation of the rules of Construel (see 7.4).

I propose to analyse the derived ERG-DAT case frame as a "diathetical variant" of the ERG-ABS alignment that these verbs would otherwise be linked with. The proposed diathetical rule affects the functional representation of the verb, in some sense "demoting" the object from Patient to Goal, so that the Linking Rules align the object argument with DAT, rather than ABS. The diathetical rule further specifies that the DAT-linked argument of the verb must be construed (at least) twice in the Auxiliary, a requirement not otherwise recognised in this account.

A consequence of the double-registration requirement is that a Dative-Adjunct Preverb (6.1.4) cannot co-occur with this diathetical variant of a verb<sup>9</sup>.

The derived nature of the ERG-DAT constructions just discussed is a candidate for analysis by Relational Grammarians as a relation-changing rule, specifically of "2-3 Retreat" (i.e. a retreat on the "hierarchy of grammatical relations" from a "2" (direct object) to a "3" (indirect object)). The analysis would no doubt include the evidence from the fact that the Retreat is optional, and its application is signalled morphologically (by the double-registration in the Auxiliary). This is just the analysis proposed by Klokeid, 1978:588, in an interesting discussion of the

---

<sup>9</sup>Such Preverbs add a DAT-linked argument to the functional representation of the verb which is also required to be construed in the Auxiliary. See 6.1.4.

expression of direct objects by means of the Dative case in four Pama-Nyungan languages, including Warlpiri, noting that:

the nominal that is the direct object in an early stratum is sometimes assigned the case otherwise associated with an indirect object, i.e. the Dative (DT).

This particular "relation-changing rule", analysed in this work as a diathetical rule, is concerned primarily with the functional representation of the verb concerned. It is the functional structure of a verb which determines whether the verb may undergo the diathetical rule, and which also expresses the semantic change brought about by application of that rule. It is basically a rule changing thematic relations, not, in Warlpiri, a grammatical relation.

#### 6.1.4 DATIVE ADJUNCT PREVERBS

There is a general process in Warlpiri by which an extra argument, always linked to the Dative case, may be added to almost any verb's case-array. The process may be captured by a lexical rule written in gross terms as follows:

- (BA) Benefactive adjunction: If a verb has the functional representation X, then it may also have the functional representation (X,Goal).  
(The added Goal is like an "ethical dative", 'for, to, about')

The Linking Rules always link this extra argument-position to DAT. This DAT argument position requires to be construed in the Auxiliary, and so there are limitations on the addition of the Benefactive to verbs which already have two DAT-linked arguments, or one DAT-linked argument requiring double-registration (as in the ERG-DAT diathetical variant of ERG-ABS verbs, 6.1.3). It is restrictions of this nature (that follow from independent requirements) that lead to the caveat that (BA) may apply to "almost any verb's case-array".

A process formally parallel to Benefactive Adjunction is triggered by any of the "Dative-adjunct Preverbs" (Hale, 1978:52-55), listed in 2.6.4.1. In fact, one of those Preverbs, *kaji ~ ngayi*, has the same semantic import as Benefactive Adjunction, and so that rule (above) can be informally thought of as involving a "null" Preverb which alternates with *kaji ~ ngayi*. The more general rule might be stated thus:



Preverb argument adjunction: If the Verb A has functional representation X, and the Preverb B has an argument position, then  
 [ [B]<sub>PVB</sub>[A]<sub>V</sub>]<sub>V</sub> has the functional structure (X, ---).

It is envisaged that further research on Linking in Warlpiri will show that the additional argument adjoined by the Preverb in this manner must be linked to DAT, particularly when the range of meanings of the Preverbs (that have an argument position) is considered. If this is not possible, then a Linking Specification could be added to Preverb Argument Adjunction, making it look like a Diathetical Rule Schema (covering a diathetical rule associated with each DAT-adjunct Preverb).

## 6.2 OTHER LINKINGS

In this section I consider various alignments of case and role that are not given by the regular Linking Rules of 6.1. First, there are idiosyncratic uses of the "grammatical" case, which do not appear to follow from general principles. A special statement has to be made in the lexical entry of a predicate exhibiting irregular linking. Following Ostler's, 1979:122, 169 terminology, I call the lexical statement of a linking irregularity a Linking specification. Second, there are some instances of an argument position apparently linked to a "semantic" case (i.e. a case label other than ERG, ABS, DAT).

### 6.2.1 SPECIAL LINKINGS

The argument position of a 1-place predicate can be idiosyncratically linked to ERG, rather than ABS. This occurs in Warlpiri in a "small set of morphologically complex body-function verbs" including:

ngungkurru-pangi-rni	'ERG snore'
ngaany-kiji-rni	'ERG breathe, expel breath'
ngalngal-kiji-rni	'ERG pant (from exhaustion)'
kuntul-pi-nyi	'ERG cough'

The likely etymology for these verbs is that "these preverbs were once true objects syntactically, and that the development of these exceptional verbs came about by means of a process of incorporation" (Hale, 1978:32). "The process of object incorporation is not a productive one in Walbiri, and these verbs must be considered lexical items -- analysable ones, to be

sure -- which from a strictly syntactic point of view, take a single noun phrase argument (i.e. a subject) which in turn, irregularly, appears in the ergative case." (ibid.)

For these verbs, the Linking Specification, that their argument link to ERG, is optional, at least for the last three listed -- they also exhibit linking to ABS.

Conversely, there is one verb of perception with its highest role argument-position linked with ABS rather than ERG, though ERG would be given by Linking Rule (4)(a). Compare the two verbs:

kanginy-karri-mi	'ABS fail to recognise DAT'
kanginy-pi-nyi	'ERG mishear, misunderstand ABS'

The latter exhibits regular Linking. The linking of the former is not necessarily idiosyncratic, for it has certain properties from which its Linking might be considered to be regular: (i) kanginy-karri-mi is a combination of the Preverb kanginy 'misperceive, fail to perceive' (cf. kanginykanginyawangu 'without failing to know') and the Verb karri-mi 'ABS stand'. The Linking of karri-mi in its basic sense is quite regular -- perhaps the Linking of a Verb sometimes persists in combination with a Preverb? (ii) an accurate representation of the meaning of kanginy-karri-mi may show that its highest role is not properly included in the Perceiver type.

Another candidate for treatment by Linking Specification is a group of "certain verbs of performance (music and dance), which appear with overt objects ... but can appear without overt objects equally well ..." (Hale, 1978:29) but still with ERG subjects. They differ from other 2-place predicates in that when the object is non-overt, it may receive an indefinite interpretation, unlike the rest of Warlpiri verbs with non-overt arguments (see 7.5). To be subject to the same special Linking Specification as the exceptional body-function verbs, these verbs of performance would have first to undergo a diathetical rule which would delete the object argument position. This "detransitivization" would be analogous, as Hale, 1978:30 remarks, to the relationship between transitive and intransitive kick in English; the Linking Specification would be additional, with no counterpart in English.

The alternative, which I adopt, is to derive the indefinite reading



in the example quoted.

And as well as yirra-rni, in the first sense given, in which it selects an Allative argument, the verb wangka-mi 'ABS speak ...'

has also been recorded in spontaneous discourse, albeit only rarely, with an allative expression corresponding to addressee, as in the following excerpt:

... nyampu-kurra-lku kuja-ka-rna wangka-mi walypali-kirra,  
 this-Allative-how Rel-Pres-I speak-NPast whiteman-Allative

ngula pina.

well knowledgeable

'... (and) when I say (this) to this whiteman, it is with knowledge (that what I am saying is true)'

Notice that, although the allative exactly parallels the dative here, it behaves properly like a semantic case in that it is not registered in the auxiliary.

(Hale, 1978:82, gloss supplied)

A final example may be:

lani-jarri-mi

'1. ABS fear, be afraid (of DAT);

2. ABS be afraid of EVITATIVE'

Note however that the Evitative argument is never registered in the Auxiliary -- see Hale, 1978:128-29.

### 6.2.3 OTHER DIATHESES

It is worth pointing out the limited nature of the diathetical rules proposed above for Warlpiri. The only rule adopted is the one deriving the ERG-DAT frame from the ERG-ABS frame of a certain class of verbs of motion and affect (6.1.3).

What diathetical rules might Warlpiri have, that it lacks? There is no Passive, or Anti-passive. And there is no Reflexive or Reciprocal -- not formed, that is, by a diathetical rule. This is connected with the fact that the Reflexive/Reciprocal in Warlpiri is marked in the (obj position of) the Auxiliary, and not at all on the verb (though the Auxiliary may happen to cliticise to a verb). Thus Warlpiri follows the general pattern observed by Edmondson, 1978:646-7:

Of those ergative languages I have consulted many with verbally encoded reflexives have subjects with absolutive markers, indicating that these languages regard TV (transitive verb) + reflexive as intransitive .... When the reflexive is encoded as a noun or pronoun, ergative languages generally regard the verb as transitive, i.e. the subject takes an ergative marker. This is, however, not the entire story ...

The subject of a reflexive in Warlpiri has the same case were the clause not reflexive, and the reflexive/reciprocal is "encoded as a ... pronoun", in the extended sense in which the pronominal person/number-marking clitic nyanu (2.7.1) is a "pronoun".

It is interesting to note, further, that the related language Nyangumarda chooses the alternative means, i.e. treating all reflexive/reciprocal subjects as ABS (as was pointed out by Hale, 1979:75n32). The only relevant respect in which Nyangumarda differs from Warlpiri is that the person/number-marking pronominal suffixes attach always to the verb, rather than to a non-verbal AUX as in Warlpiri (Hoard & O'Grady, 1976:62-63). Apparently this fine distinction is typologically significant.

Nor are there any "advancements" in Warlpiri -- at least, not as general diathetical rules of diathesis (they may appear as special possibilities for some particular group of verbs, depending on the analysis). Certainly there are no "voice" phenomena (unless the ERG-DAT diathesis rule, with double Auxiliary-registration, counts as a "voice" process, which I presume not).

### 6.3 LINKING IN NOMINAL PREDICATES

The remarks about the possible case frames in 6.1 apply equally to non-verbal predicates as to the verbal predicates discussed in 6.1.1 - 5.

No doubt because of the range of meanings encompassed by nominal predicate expressions, (i.e. primarily stative), an argument position of such a predicate is never linked to ERG. Thus the normal case-frames exhibited by nominal predicates are just:

1. ABS
- 2.(ii) ABS - DAT

The first of these applies to all one-place non-verbal predicates, including all Predicational uses of substantival nominals (2.2, 7.3.2). The two-argument frame is found with certain Nominals with an adjectival focus, and with relational Nominals (in the domain of kinship). I consider these types in turn.

### 6.3.1 PREDICATIONAL ELABORATION OF N

A substantivally focussed Nominal (2,2) may also be used predicationally, according to the following rule:

#### (12') Thematicisation

Let X be a Nominal, with no Theme but possibly with other argument positions. Then there is a predicate with linked functional representation 'ABS be X'.

There is probably no need to specify in the rule (12') that the Nominal not have a Theme before application of the rule, as it is generally recognised that no predicate may have two argument positions with identical roles. (The additional argument position added by rule (12') is clearly a Theme, and the rule would be blocked by the more general constraint in the case that X has a Theme.) In any case, rule (12') cannot apply to its own output.

For examples of Nominals as predicates, see 5.4.3.2 and 7.3.2.

There may be some Nominals that are necessarily substantival or individuating, to such an extent that rule (12') cannot apply to them. The Nominals most clearly exhibiting this property are the pronouns and articles. For instance, nyanungu 'the aforementioned', yangka 'that (evocative), the one you know about' are rarely, if ever, observed in Predicational contexts.

As one might expect, there appear to be ways of reversing the effect of Thematicisation in the case of predicates which do have a Theme. For instance, wiri 'big' has two uses, depending whether it exhibits a theme: '1. a/the big one; 2. ABS be big'. The former meaning is the only one for wiri-pirdinypa 'a/the big one, one which is big', involving the suffix pirdinypa 'Definite Specific' (2.3.1.1) (Kenneth Hale, p.c.). Indeed, there may be reason to analyse the semantic effect of suffixing pirdinypa to a substantivally-focussed Nominal as involving the same process. Thus wati-pirdinypa 'only the man' might have a meaning composed first by applying rule (12') to wati 'man' (deriving 'ABS be man'), then by applying the

"restrictive relative" effect of pirdinypa (to derive 'one who is a man'). In this account, these speculations are taken no further.

### 6.3.2 NOMINALS WITH COMPLEMENTS

The following Nominals are "adjectivally focussed", and may take a complement bearing the Dative case.

ngampurrpa	'desirous of DAT, wanting DAT'
jukuru	'not desirous of DAT, apathetic (about DAT)'
pina	'knowledgeable about DAT'
ngurrpa	'ignorant of DAT, unknowing'
lawa	'1. no; 2. negative, absent; 3. lacking in DAT'
[palka	'present; manifest' does not take a complement]

Textual examples of their use include the following:

- (12) Ngurrpa ka-rna ngaju-ju kulu-ku-ju nyina.  
 ignorant Pres-I I-Top fighting-Dat-Top be  
 'I don't know about fighting, how to fight' (Hale, 1959:753)
- (13) ... kala yirdi-ki-lki kula-rna pina ngajulu-ju.  
 but name-Dat-then Neg-I knowledgeable I-Top  
 'but right now I don't know the name' (Hale, 1966:722)
- (14) Wilypiri-rla-yijala ka nyina -- kurdu-ju --  
 hollow -Loc-also Pres be child-Top  
pina-jala-rna-rla pangarra-ku-ju, wilypiri-rla, yi-rna-lu ma-nu.  
 know-actually-lll bird sp.-Dat-Top hollow-Loc Causal-lll get-Past  
 'It also lives in a hollow log, the baby -- after all, I know  
 (about) the Northern White cockatoo, since we got it from  
 hollow logs' (Hale, 1966:604)

Notice the variation in the Auxiliary: usually, as in (12) and (13), the Dative argument is not registered in the Auxiliary, but in some sentences, as in (14), it is. The Dative in (14) that is registered in the Auxiliary also bears the Topic enclitic ju, though this does not force Dative registration, as (15) shows:

- (15) Lawa-rna yimi-ki-ji.  
 negative-I language-Dat-Top  
 'I don't have any language' (Hale, 1959:137)

Nevertheless, the presence of a pronominal clitic in the Auxiliary construed with the DAT argument does seem to add somewhat to the definiteness of the interpretation of that argument. (Cf. 7.5).

Two further examples, without Auxiliary registration of the Dative, are the following:

(16) Kapi-rna lawa-lku nyina warrki-ki.  
 Fut-I negative-then sit work-Dat  
 'Then I'll be without work' (Hale, 1959:441)

(17) Ngaju-rna lawa wawirri-ki partt-rni-nja-wangu.  
 I -I negative 'roo-Dat spear-Inf-Privative  
 'I haven't speared a kangaroo' (Hale, 1968:51)

Kinship Nominals may introduce a Dative "complement", which may (must?) also be registered in the Auxiliary, as the following examples show:

(18) Yalumpu-ju, nyuntu-ku-ngku warringiyi.  
 that-Top you sg.-Dat-2 father's father  
 'That [person] is your father's father' (Hale, 1959:390)

(19) Ngaju-rna-ngku nyuntu-ku-palangu jaja,  
 I -I-you sg. you sg.-Dat-ascending generation MoMo  
 ngaju ka-rna-ngku ngarri-rni nyuntu: mirntirdi.  
 I Pres-I-2 call-NPast you sg. SiDaCh  
 'I am your mother's mother, I call you sister's daughter's  
 child.' (Hale, 1966:902-3)

For details, see Laughren, forthcoming.

The object of Comparison of an adjectivally-focussed Nominal may be expressed by a Dative argument, which may or may not be registered in the Auxiliary. Consider the following examples:

(20) Ngaju-rna wiri nyampu-ku.  
 I -I big this-Dat  
 'I'm bigger than this [person]' (Hale, 1959:345)

(21) Wawirri, kanyarla-ku-rla wiri.  
 kangaroo euro-Dat-Dat big  
 'The kangaroo is bigger than the euro' (Hale, 1959:345)



(22)(a) Nyuntu-ku-ju ka-rna wiri nyina ngaju-ju.  
 you-Dat-Top Pres-I big sit,be I-Top  
 'I'm bigger than you.' (Hale,1966:313)

(b) Ngaju ka-rna-ngku nyina wiri nyuntu-ku-ju.  
 I Pres-I-you sit,be big you-Dat-Top (ibid.)

The range of comparative constructions and their integration into the grammar is beyond the scope of this work. The construction may also be more general than the comparative, however. In the following sentence, the borrowed term tumaji with Dative complement precedes the Auxiliary:

(23) Tumaji ngaju-ku-ju wiri ngawarra yali-ji -- kula-lpa-rna  
 too much I-Dat-me big flood that-Top Neg-Imp-I  
 ya-nta-rla jingi<sup>2</sup>.  
 go-Irr through  
 'That big flood is too much for me -- I can't go across it.'  
 (Hale,1966:358)

In (23), the sense is not just that 'the flood is bigger than me'.

The "complement argument" of the Nominals discussed to this point (including kinship terms, and comparative complements) is regularly linked with the DAT case label. Linking Rule (4)(c) is at work here, as the complement argument generally ranks lower on the role hierarchy (2) than the predicational "theme".

There are also Nominals with complements apparently linked with a "semantic" case (cf. 6.2.2, for Verbs). These include Nominals built on the six cardinal directions, and also:

kulkurru	'midway'
parrpada	'beyond, far'
kamparra	'ahead'
purdangirli	'behind'
kut:	'close'
wurnturu	
pinka }	'far'
munparra	'very far'
jingijingi	'through, during'

The "argument of reference" of these spatial expressions evaluates an argument-position that is linked with Locative (and, perhaps with a difference in the degree of "intimacy of connexion", with DAT). Furthermore, the notion of separation in wurnturu 'far' and kulkurru 'midway' allows the argument-position of reference to be linked with Elative:

(24) Ngaju ka-rna nyina-mi wurnturu Yurntumu-ngurlu.  
 I Pres-I sit-NPast far (place name)-Elative  
 'I live far from Yuendumu.' (Hale, 1978:66)

(25) Kurdu-ju kapa juul-karri-mi kulkurru ngurra-ngurlu.  
 child-Top Fut stop-stand-NPast midway camp-Elative  
 'The child stops on the way, at some remove from the camp.'  
 (Granites, 1976:1)

See Hale, 1978:64-66 for further exemplification and discussion.

Apparently an "object of Comparison" may also be expressed by cases other than the Dative. Consider the following way of expressing the meaning of (22) above:

(26) Nyuntu-ngurlu ka-rna nyina wiri-ji ngaju-ju.  
 you-Elative Pres-I sit,be big-Top I-Top (Hale,1966:398,(W))

## CHAPTER 7: SEMANTIC INTERPRETATION

## 7.1 INTRODUCTION

The input to the Semantic Interpretation component is "Shallow Structure", the form of a sentence at the point in a derivation where the Rules of Form and the Semantic Interpretation-Rules each take over and continue derivations separately. These shallow structures for Warlpiri are the output of the rules in Chapter 5.

A string of words under a single root node corresponds to the notion of "sentence". In Warlpiri, such a non-terminal root node could be labelled V, N or INF (by the operation of the Labelling Rules of section 2). That label is called the governing category of the expression, and a word immediately dominated by such a node is said to be governed by it, and, indirectly by the terminal node of the same category as the governing category (from which the governing category gained its label by operation of a labelling rule). Thus, in the sentence (1),

(1)

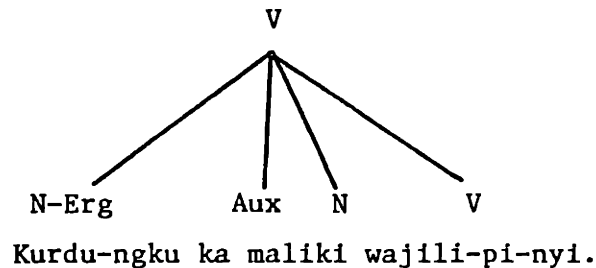

assuming the given structure has been derived from the processes of Chapter 5, it will be said that maliki, for example, is governed by V, and also that maliki is governed by wajili-pi-nyi.

In this chapter I sometimes use braces, {}, to indicate the semantic expression associated with a syntactic node or nodes. The braces specify some of the bracketing that would be present in a more detailed semantic interpretation.

A string of words under a single root node, a sentence, is provided with a "reading", or a "semantic interpretation", by Rules which build a semantic structure giving some of the elements of meaning of the sentence. The first approximation to the meaning of a sentence may be taken to be its "logical form" (LF) -- an expression of predicate logic which is entailed by the meaning of the sentence. (See Chomsky, 1980 and the references

there for further definition of LF.) It is just this 'skeleton meaning' that is determined in part by the rules presented in this chapter that we focus on.

The major elements from which the Semantic Interpretation-Rules construct the logical form of a sentence are the logical representations of immediate daughter of the "shallow structure" of the sentence. These elements are derived from (i) the categorial signature of the given node, and (ii) the syntactic character of the given node. For instance, the linked functional representation (Chapter 6) of a predicate node is of central importance.

The specific Semantic Interpretation Rules sketched in this chapter are:

Merger (7.2)

Construal - of pronominal clitics (7.3.1)

- of controlled argument positions (7.3.2)

- of Predicational adjuncts (7.3.3)

Tense/aspect (7.4)

Evaluation (7.5)

I summarize the function of each of these rules, by way of defining them, and comment on the logical relationships and the implicit (intrinsic) orderings between them. I also relate the proposed rules to their counterparts in Hale, 1979.

The chapter closes with a brief account of order-dependent processes, and Semantic Interpretation which integrates two or more finite clauses.

## 7.2 MERGER

The rule of Merger brings together the identically marked constituents of a discontinuous expression, and assigns a single semantic unit to them. For instance, in a sentence such as (2), with the given interpretation,

- (2) Kurdu-jarra-rlu ka-pala maliki wajili-pi-nyi wita-jarra-rlu.  
 child-Dual-Erg Pres-33 dog chase-NPast small-dual-Erg  
 'The two small children are chasing the dog.'

the two expressions with categorial signatures N-NUM (2)-ERG, viz. kurdu-jarra-rlu and wita-jarra-rlu, are "merged". More precisely, their

semantic representations are merged, to form the single semantic expression

(3) {Kurdu,wita}-jarra-rlu '(small child)- $\left[ \begin{array}{l} -sg \\ -pl \end{array} \right]$  -Erg'

This semantic interpretation, (3), will also be that assigned to an "incorporated" expression such as (4), built by the labelling rule of 5.4.1:

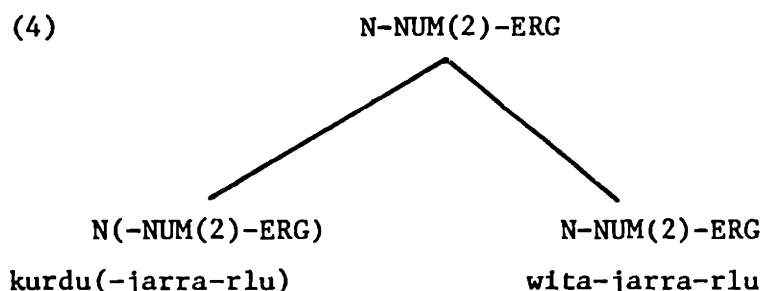

Hale's, 1979:35,45 formulation of Merger went as follows:

(39) Semantic expressions sharing identical categorial signatures may be merged.

and he noted that the rule applies:

to semantic expressions associated with syntactic expressions which are immediate sub-expressions of a sentence.

The requirement that candidates for merger have "identical categorial signatures" is not strong enough, at least in the framework set up in this treatment. There are expressions with identical categorial signatures, e.g. two Infinitives, or two finite verbs (even with the same tense inflexion) which cannot, in Warlpiri, be merged. Hence I propose this formulation:

(5) Merger

Let  $n_1$  and  $n_2$  be (not necessarily terminal) sister nodes of a sentence, both with categorial signature N-A (A possibly null). Thus  $\{n_i\} = E_i - A_i \quad i = 1, 2$ .

Then optionally associate with  $n_1$  and  $n_2$  the merged semantic expression  $\{E_1, E_2\} - A$

How two semantic expressions are "merged" has yet to be made explicit. At this stage the clear example from (2) above, wherein 'child' and 'small' are merged to form (3) 'small child' is prototypical. It shows that two

expressions merge by (i) forming the combination of the two N expressions, and (ii) carrying over the common syntactic features (e.g. number, and the particular case and complementiser labels).

The important point about Merger is that the semantic interpretation of a merged output of two expressions has in each instance a counterpart in another possible sentence in which the two nodes ( $n_1$  and  $n_2$  above) are adjacent, combine syntactically, and undergo Labelling by the labelling rules of 5.4.1, and receive a single semantic interpretation, which is identical to the interpretation which is the output of the Merger of the same two nodes when they are not (necessarily) adjacent, but merely sisters. That is, however the single semantic interpretation (3) is to be assigned to the non-terminal node in the incorporated expression (4), the same mechanisms give the same interpretation (3) to the merger of kurdu-jarra-rlu and wita-jarra-rlu in (2).

Hence Merger may be seen as the "inverse" of a Scrambling Rule, which, in an alternative approach to Warlpiri syntax, would break up adjacent identically-marked nominal-based units and "scramble" the constituent expressions to any position within the finite sentence. Whatever constraints would need to be placed on a putative Scrambling Rule in such an alternative approach also show up as constraints on Merger in the approach taken here: the most significant being the "sisterhood constraint", written into the structural condition of Merger, which achieves the effect of "within finite sentences" just mentioned. (See further discussion of the "Scrambling" alternative in 5.1.3, - "R-Permutation" operates "within S".)

It is envisaged that, in either approach, the "sisterhood convention" or its equivalent (Hale, 1979:46) is not actually stipulated in the rule of Merger, or any other rule where it is needed. It has the character of a language universal comparable to the Propositional Island Constraint (Chomsky, 1980:7, passim).

Another merger process, which I call Complement Merger applies to a complement expression not adjacent to the predicate of which it is the complement. And just as Merger, (5), parallels Complex Nominal Labelling (5.4.1), so Complement Merger parallels Complement Labelling.

The expression taking a complement may be a Infinitive, or one of the class of Nominals which take a complement (6.3.2). A typical example

of the complement of an Infinitive separated from the Infinitive occurs in (6); and (6) has the same meaning as (7) which has the complement Nominal adjacent to the Infinitive:

(6) Ngarrka-ngku marlu marna-kurra luwa-rnu, nga-rni-nja-kurra.  
 man -Erg 'roo grass-Obj shoot-Past eat-Inf-Obj  
 'The man shot the kangaroo eating the grass.'

(7) Ngarrka-ngku marlu luwa-rnu marna nga-rni-nja-kurra.  
 man -Erg 'roo shoot-Past grass eat-Inf-Obj

Sentence (7), in the same reading as provided for (6), has a constituent:

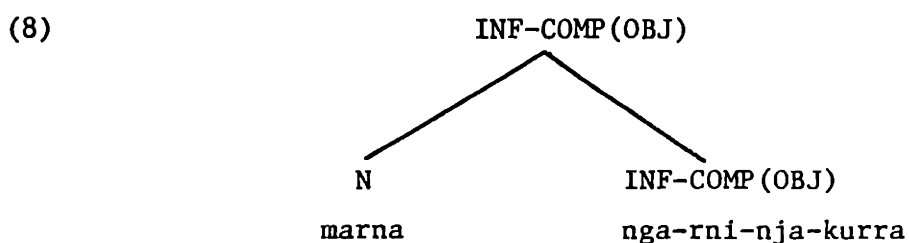

Similarly, for Nominals with a complement, the complement may be separated from the Nominal of which it is a complement. (See examples (12"), (13), (23) in 6.3.2, all of which illustrate such separation, and furthermore (14)-(16), (18) and (22)(a) in 6.3.2 have the Auxiliary between the Nominal and its complement.)

Hence, a rule is required with the effect provided for in the following tentative formulation:

(9) Complement Merger

(a) Let  $n_1$  and  $n_2$  be sister nodes of a sentence with categorial signatures N - A and INF - A respectively. Hence

$$\{n_i\} = E_i - A; \quad i = 1, 2.$$

Then optionally associate with  $n_1$  and  $n_2$  the semantic expression  $\{E_1, E_2\} - A$ .

(b) Let  $n_1$  and  $n_2$  be sister nodes with categorial signatures N and N - A respectively. Then optionally associate with  $n_1$  and  $n_2$  the semantic expression  $\{\{n_1\}, \{n_2\}\}$ .

Thus, (9)(a) may apply to (6) with

$$\begin{aligned} X_1 &= N - \text{COMP(OBJ)} \\ X_2 &= \text{INF} - \text{COMP(OBJ)} \end{aligned}$$

to associate with marnakurra and ngarninjakurra the expression {marna, ngarninja}-kurra. Subsequently, the rule of Evaluation allows marna 'grass' to fill the ABS-linked argument position of ngarninja '(ERG) eat ABS'.

Note the formal similarity between (5) Merger, and (9)(a) Complement Merger of a nominal and an Infinitive. The difference between them lies in the sort of semantic amalgamation that is appropriate between  $E_1$  and  $E_2$ . The output of (9)(a) (and (b)) will feed the rule of Evaluation (7.5), but the output of (5) does not.

### 7.3 CONSTRUAL

The term "construal" has traditionally been used for any association between two expressions in a sentence. In this section I follow a recent usage, according to which rules of construal "relate anaphors to antecedents" (Chomsky, 1980:6, and references there).

The range of anaphoric devices in Warlpiri includes:

(i) anaphoric pronouns

nyanungu 'the, that aforementioned, the former'

ngula 'that one, (referring back to prior clause in a complex sentence)'

and to an extent the other determiners, including

yangka 'the, that evocative'

(Hale, 1974:9-10). Note also the usage:

nyanungu-piya(-jarra) 'like each other'

(ii) pronominal clitics (2.7.1)

The referential and anaphoric properties of independent pronouns and Auxiliary pronominal clitics are relevant for construal. There are two special devices:

(a) "zero-anaphora", the '3rd person sg.' reading implied when the Auxiliary has no overt subject or object pronominal clitic, or the Dative rla clitic, which is freely interpretable as coreferent with any 3rd person singular expression.

(b) the reflexive/reciprocal pronominal clitic nyanu, which fills the 'object slot' in the Auxiliary.

(iii) two anaphoric suffixes, listed in 2.3.1.1:

(a) the kinship possessor nyanu





inflected words is generated by the base. Included in that string may be a member of the category Auxiliary, (2.7.1), which includes positions subject and object for subject and object pronominal clitics.

Hence, this account of Warlpiri grammar is similar here to the treatment of pronominal clitics in the Romance languages by Rivas, 1977. In his account, clitics are generated in pre-verbal position (one normal surface position)(p.34), and then a rule of "CL/NP Agreement"(p.65) applies to check "whether one CL and one NP agree in case, person, number and gender". But a respect in which my account differs is in the association of the clitics with argument positions, not nominal expressions.

Pronominal clitic construal associates the subject and object pronominal clitics in the Auxiliary expression with the case-linked predicate argument positions of the predicate which governs the Aux -- "a 'partial evaluation' of the variable occupying the relevant argument position" (Hale, 1979:41). This corresponds with the traditional notion of clitic "agreement"; see Hale, 1979:34, 39-40, 45. The person and number information represented by features in the clitics are mapped onto the predicate argument positions of the governor, which is required, for Construal, to be a root node (effectively, then, the governor is an N or V, and never an INF).

If the governor is V (not INF), the Aux base looks to the verbal inflexion to participate in the tense/aspect reading of the sentence (cf. Hale, 1979:44). Hence, it is a fact about Warlpiri that a (non-zero) Auxiliary base will fail to gain an interpretation if it occurs in a governing category other than V (i.e. in N).

The features of subject and object argument positions that come from the Aux must agree with the features of the nominal expressions that will be associated with those positions by the rules of Evaluation below. At least, this is true of nominal expressions that directly evaluate an argument position. However, nominal expressions which are predicational adjuncts (7.3.3) of an argument position may have person/number features which clash with those from the Auxiliary. This will easily be the case for the Instrumental or Body Part interpretation, for instance. Furthermore, factors of animacy and etiquette sometimes sanction clashes of number marking -- see Laughren, 1977.

See details of morphology, rules of form, and construable arguments in Hale, 1973a, and the last in Hale, 1978 to some extent. Of particular interest is the requirements that certain Datives be registered in the Auxiliary (Hale, 1978:48-50); and that 1st and 2nd person arguments must be represented in the Auxiliary. Perlmutter, 1971:89-94 also discusses Waripiri pronominal clitics.

A further device of interest is the comitative usage of the Dual, construed as in:

- (10) Jungarrayi-jarra-npala ya-nu.  
 (name)-Dual-22 go-Past  
 'You (not necessarily a Jungarrayi) and Jungarrayi went.'  
 (Laughren, 1977:8)

In interpreting (10), Jungarrayi-jarra is (optionally) read as 'with Jungarrayi' and not as a Dual, by an ill-understood process. See however Laughren, 1977 for an analysis of jarra encompassing this usage.

Two typical examples of pronominal clitic construal are the following:

- (11) Maliki-patu-rna-jana nya-ngu.  
 dog-Plural-I-them see-Past  
 'I saw the dogs.'

In (11), the Auxiliary consists solely of the subject-object sequence,

-rna-jana	
+I	-I
-II	-II
+sg	-sg
-pl	+pl

The features of the subject part are associated with the "subject" of the predicate, viz. the Verb

nya-nyi 'ERG see ABS'

and the features of the object part with the "object" of the verb.

- (12) Kurdu-patu-ku ka-rna-jana-rla karli-ki warri-rni.  
 child-Plural-Dat Pres-I-them-Dat boomerang-Dat seek-NPast  
 'I'm looking for a boomerang for the kids.'

In (12), the Auxiliary consists of the pronominal clitic sequence rna-jana-rla on the Auxiliary "base" ka. The features of the subject part of the Auxiliary are associated with the "subject" of the predicate. The predicate is formed from the verb:

warri-rni                    'ERG seek DAT',

by applying Benefactive Adjunction (6.1.4 (BA)):

warri-rni                    'ERG seek DAT for DAT'.

The two object clitics are each associated with a DAT-linked argument.

The definitions of "subject" and "object" that are used correspond very closely, if not exactly, to those quoted from Hale et al, 1977:413 in 2.3.4, which, in the shorthand of linked-case, are as follows:

"subject" = ERG, else ABS

"object" = DAT, else ABS

An alternative pair of definitions is possible in terms of the thematic hierarchy -- see 6.1 (5). The empirical difference between the two types of definition (in terms of case-labels, or in terms of thematic relations) arises in constructions with two identical case-linked argument positions, but the evidence turns out to be quite slim.

- (i) There is one verb which may be analysed as having two argument positions both linked with ABS -- the "cognate object" construction of 6.1.2. There the argument position with the more prominent of the two thematic roles is the one always registered in the Auxiliary -- see 6.1.2 (9).
- (ii) There are several constructions which have more than one argument position linked with DAT -- see 6.1.3-4. The Auxiliary is able to register two Datives; but if a third Dative is introduced the sentence is ungrammatical. Hence the ERG-DAT frame requiring double-registration (6.1.3) cannot co-occur with a Dative-adjunct Preverb (6.1.4), and we are unable to test which of the competing Dative arguments would be registered in the Auxiliary. (The distinction between Dative arguments with differing thematic roles shows up in the obviation system, in the choice between the Objective Complementiser kurra(-ku), and the Obviative Complementiser rlarni (7.3.2))

Each pronominal clitic must be construed with an argument position to be interpreted. Failure of construal renders the sentence ungrammatical. Note also that pronominal clitic construal must operate in terms of the abstract person and number features. The rules of form (metathesis (2.7.1), imperative deletion, dual neutralisation) which apply to the pronominal clitics (Hale, 1973a:337), are independent of construal.

### 7.3.2 CONTROL AND OBVIATION

This section surveys the syntax of Complementisers, which occur suffixed to Infinitives and Nominals -- see 2.3.3 for a complete list.

The [ $\pm$ C] subdivision of the Complementisers is motivated in 2.3.3 on purely morphological grounds -- just the [+C] Complementisers may take a following Ergative or Dative suffix. The syntactic classification of Complementisers cuts across the morphological division, since it refers to the "obviation" properties of the Complementisers.

The basic function of every Complementiser is to relate the semantic expression it marks to an argument position of the governing predicate. Some Complementisers, specify quite closely just which predicate argument position they must be associated with, and it is these that may be said to constitute the "obviation" system, or "structures of obligatory control". These are the following:

- (i) the Proximate Complementisers, which are controlled by the subject of the governing predicate:

<u>karra</u>	'Proximate Contemporaneous' (some speakers)
<u>rla</u>	'Proximate Sequential'
<u>rla-jinta</u>	'Proximate Reflexive Accidental'

- (ii) the Complementiser is controlled by the object of the governing predicate

<u>kurra</u>	'Objective' (some speakers; others allow Prox) (the traditional proximate/obviative terminology does not provide for this intermediate case)
--------------	---

- (iii) the Obviative Complementisers, which generally may not be controlled by an argument of the governing predicate:

<u>rlarni</u>	'Pure Obviative'
<u>puru</u>	'Concurrent Obviative'

The remaining Complementisers appear to relate freely to arguments of other predicates, or other expressions, in the manner of "zero anaphora" (7.3(ii)(a)). These include:

<u>ku</u>	'Purposive'
<u>ku-purda</u>	'Desiderative Purposive'
<u>ku-ngarnti</u>	'Preparative Purposive'
<u>ku-jaku</u>	'Negative Purposive, Evitative'
<u>warnu</u>	'Resultative'
<u>wangu</u>	'Negative'

However, there is more to be said about the construal of expressions marked with these Complementisers. For instance, it appears that certain verbs of command, as well as certain stative verbs (in -jarri-mi) may impose a constraint on the construal of a Purposive expression which they govern, in the manner of obviation. (See Hale, 1978:91-95). Further study of these matters will no doubt be illuminated by investigation of the details of anaphora, which is not undertaken in this work, beyond the brief remarks in 7.3.

In the above classification of the obviation Complementisers (i)-(iii), the term "subject" is used in the sense defined in 6.1(5). The definition of "object" there, however, is not exactly the one used in the distinction between the 'Objective' kurra and the 'Pure Obviative' rlarni. It is more accurate to say that a kurra Complementiser is construed with argument positions having a thematic role such as Theme, Patient, and certain Goals, whereas a rlarni Complementiser may be construed with argument positions lower on the thematic hierarchy (Chapter 6,(2)) such as the Goal of parda-mi 'ABS wait for DAT', or the argument position of a Dative-adjunct Preverb (6.1.4), or a Dative having nothing to do with the main predicate (as in the sentences (24), 7.6.1.1). (See Hale, 1978:109-11). A rlarni Complementiser is thus always construed with a Dative, except for those speakers who express the complement subject with an Ergative (7.6.1.1(26)). A rlarni Complementiser is never construed with an argument-position linked with ABS, where a kurra is typically used. But case-labels alone do not distinguish those Datives which construe with a kurra(-ku) Complementiser, and those which construe with a rlarni Complementiser -- the thematic hierarchy is required, it seems, and perhaps other principles.

A typical example of a kurra Complementiser construed with a Dative is in the following sentence:

- (13) Ngarrka ka-rla yura-ka-nyi marlu-ku, marna nga-rni-nja-kurra-ku.  
 man Pres-Dat stalk-NPast 'roo-Dat grass eat-Inf-Obj Comp-Dat  
 'The man is sneaking up on the kangaroo while it is  
 eating grass'

An example in which the DAT-linked argument position is the result of the ERG-DAT diathetical rule (6.1.3) is the following:

- (14) Ngarrka-ngku-rla-jinta marlu-ku pantu-rnu, marna  
 man-Erg -Dat-Dat 'roo-Dat spear-Past grass  
 nga-rni-nja-kurra-ku.  
 eat-Inf-Obj Comp-Dat  
 'The man tried to spear the kangaroo, while it was  
 eating grass'

Other examples of kurra Complementisers are in 2.5, 2.7.2, and 4.2(iii)(24).

The [+C] Complementisers bear an Argument suffix (Ergative, resp. Dative) when construed with an argument position that is linked with a "grammatical" case (ERG, resp. DAT). For kurra, at least, this is optional; and for rlarni it is uncommon enough that I have classified rlarni as [-C]. In fact, in the usages I have been describing, an Argument marking on kurra, rlarni, or any of the obviation system complementisers is strictly redundant, since the shape of the Complementiser itself is enough to specify the argument position with which it is to be construed. The additional Argument marking does have a disambiguating function, however, for those speakers for whom the kurra or karra Complementisers have a more general usage, as 'Contemporaneous, shared argument' markers -- not the dialects focussed on in this section.<sup>1</sup>

See Hale, 1976c:81-84, 1978:90-123, and 1979:68-69 for further discussion of the construal properties of the Complementisers.

Most Complementisers, including all within the obviation system, have a property which we might call subject control. This means that the

---

<sup>1</sup> As far as I know, the speakers who allow more general uses of karra or kurra do not vary in their usages of the other Complementisers given here.

argument position of the governing predicate (with which the Complementiser is construed, for the Complementisers other than puru) is "bound" (i.e. specified as coreferent) to the subject argument position of the Infinitive bearing the Complementiser. Any example sentence with a shared argument between the Complementiser and its governing predicate illustrates this property. Examples for kurra and rlarni have already been mentioned; for karra see 2.7.2 and 4.2(iii)(24) (where note the contrasting kurra example in each instance; see also Granites, 1976:3 for the contrast); for rla see 5.6.1; examples of rlajinta are throughout 7.6.1.1, and see 5.4.2.1(26). The puru Complementiser is quite specialised, occurring only when giving concurrent background information, such as about weather -- see the example in 7.6.1.2(27). The subject of an Infinitive marked with puru may also be marked with puru, and is never an argument of the governing predicate.

The Complementisers not in the obviation system also exhibit subject control. The Purposive, and the other Complementisers built on it, in fact require subject control, as mentioned earlier -- see the examples in 2.4.1(c), 4.2(i)(23), and 7.6.1.2( ) (where ku occurs on a Nominal and an Infinitive). (The Stative Purposive, karda, which occurs only on Nominals, is exemplified in 4.2(i).) The example of wangu in 6.3.2(17), and of warnu-rlu in 2.7.2, each appear with readings consistent with subject control, but further examples show that this is not generally true. Compare the following two sentences, where the object of the warnu Complementiser is coreferent with the (subject, as it happens) argument of the governing predicate:

- (15)(a) Kurdu ka warna-jangka murru-murru-nguna-mi  
 child Pres snake-Result            sick-lie-NPast  
 yarlki-rni-nja-warnu.  
 bite-Inf            -Result  
 'The child is lying ill, whom the snake bit', or  
 'The child is lying ill, having been bitten by the snake'

- (b) Kurdu ka murru-murru-nguna-mi, warna(-ngku)  
 child Pres            sick-lie-NPast    snake(-Erg)  
 yarlki-rni-nja-warnu.  
 bite-Inf            -Result            (same meaning as (a))



Note that in (15)(b) warna may evaluate the subject argument position of yarlki-rni-nja even when not marked with Ergative. This possibility is apparently restricted in occurrence to a Nominal immediately preceding the warnu Complementiser (and thus arises only with an expression formed by Infinitival Complement labelling, 5.4.2.1(27)), and does not follow from the general rules proposed in this work.

### 7.3.3 PREDICATIONAL ADJUNCTION

There are a number of constructions in Warlpiri other than the complements considered in 7.3.2 in which a control relation may be assigned. It may be stretching the concept of "control" somewhat to do this, so I use the term Predicational Adjunct for the construal relations to be mentioned in this section.<sup>2</sup>

Predicational Adjunction is the association of an expression with an argument position of the governing predicate. The "association" has varying degrees of indirectness, and is to be contrasted with the "direct" association provided by the Evaluation rule, 7.5. A crucial difference between "direct"(Evaluation) and "indirect"(Predicational Adjunction) association of an expression with an argument position is that former is precluded if the argument position is "bound", that is, in a structure with "subject control", as defined in 7.3.2.

The types of Predicational Adjunction in Warlpiri include:

- (i) the adjunction reading of nominal predicates (6.3.1); the central type of Predicational Adjunction in English. (Hale, 1979:36n22)
- (ii) the adjunction of a nominal predicate (or even a Complementiser) to the object argument position of a reflexive construction -- a special instance of (i). A good example occurs in 4.2(iii)(24), where yama is associated with the object argument position of nya-nyi, and so is the kurra Complementiser. Note the remarks on the reflexive construction in 6.2.3, and by Hale, 1979:73n30.

---

<sup>2</sup> Bresnan uses this term for constructions in English similar to (i). (Lecture Notes, Spring 1979). J.R. Ross suggested "De-Whenning" in a squib on the same topic. Williams, 1980 analyses "obligatory control" constructions in English as instances of a general notion of "Predication".

(iii) the adjunction of a nominal denoting a body-part to an argument position which is in turn evaluated as the "owner" of the body-part. This is the required construction for expressing body-parts as predicate arguments; to use direct Evaluation implies "alienable" rather than "inalienable" possession of the body-part.

An example is:

- (16) Kurdu-ngku ka-ju wirliya-jarra-rlu kati-rni.  
 child-Erg Pres-me foot-Dual-Erg weigh down-NPast  
 'The child's two feet are weighing me down; the child  
 is stomping on me with both feet'

wherein wirliya-jarra is adjoined to the subject argument position of kati-rni, which is Evaluated by kurdu-ngku, as is clearly shown by the number-agreement in the Auxiliary pronominal clitic sequence. If the '3rd person dual subject' clitic pala were to appear in the Auxiliary, this would mean that wirliya-jarra is directly Evaluating the subject argument position, and hence are to be interpreted as disembodied.

Furthermore, the phenomena of (ii) and (iii) may co-occur, as they do in (17):

- (17) Warrpalypardu-nyanu walu-ku yarnka-ja.  
 (name) -Refl head-Dat grab-Past  
 'The ogress (W.) grabbed herself by the head'  
 (Dinry Japaljarri, Kanajingirliyanu)

In (17), the body-part walu is adjoined to the DAT-linked argument position of yarnka-mi, which is also bound to the subject by virtue of the Reflexive pronominal clitic nyanu.

There are indications that the reflexive construction does not bind so tightly lower ranking (thematically) argument positions, such as that added by virtue of Benefactive Adjunction (6.1.4). The following sentence shows that a pronoun may Evaluate a Benefactive argument position, yet a pronoun is generally not able to be used predicationally (as mentioned in 6.3.1): (note that in a reflexive imperative, ngku may replace nyanu)

- (18) Kuyu-ngku wanarri ka-ngka nyuntu-ku.  
 meat-you sg. thigh take-Imper you sg.-Dat (Hale, 1959:[22])  
 'Take a thigh [piece of carcass] for yourself'

(iv) the adjunction of [+C]-based expressions to a predicate argument position with matching "grammatical case" label -- a generalisation of the Argument marking on Complementisers mentioned in 7.3.2. to Complementisers suffixed to nominals, and to other Nominal-based expressions with a "semantic case" marking, and (at least with respect to Ergative marking) to adverbial Nominals.

A typical example covered by the quite general adjunction process of (iv) occurs with Ergative marking on a spatial expression, as in (19):

- (19) Kurdu-ngku maliki ngurra-kurra(-rlu) wajirli-pu-ngu.  
 child-Erg dog camp-Allative(-Erg) chase-Past  
 'The child chased the dog (all the way) to the camp'  
 (Granites, 1976:1)

In this example, the presence of the Ergative suffix implies that both arguments of the verb are involved in the predication of ngurra-kurra (both the dog and the child are approaching the camp). In its absence, the sentence may be interpreted with ngurra-kurra adjoined just to the object argument position, and thus not commenting on the motion or position of the other argument of the verb. See further commentary on "double case marking" of this type in Hale, 1978; and 5.4.1.2.

(v) instrumental adjunction, a special sense available to an Ergative-marked predicational adjunct.

An example, which happens also to illustrate Merger 7.1(5), and further shows that the ERG-linked argument position does not need to be directly evaluated (other than by the pronominal clitic) is in the following textual sentence:

- (20) Pulyku-ngku ka-lu wawirri-jangka-rlu wari-ni.  
 sinew-Erg Pres-they 'roo-Elat-Erg tie-NPast (Hale, 1966:146)  
 'They tie it [hook] with sinew from a kangaroo'

Further examples are in 4.4.1(55), and 4.4.2(1i)(62).

Once Predicational Adjunction is extended, as in (v), to provide instrumental interpretation, we have an explanation of the following facts of Warlpiri: (a) an Ergative-marked expression may be used as an

instrumental only in sentences in which the governing predicate has an argument position linked with ERG (in 2.3.4 I mention the typological significance of this); (b) an Ergative-marked expression in instrumental interpretation does not require "clitic agreement" in the Auxiliary (7.3.1); and (c) the instrumental use of the Ergative suffix shows no allomorphic variation not exactly paralleled by all other uses of the Ergative suffix.

## 7.4 TENSE AND ASPECT

A Warlpiri sentence expresses tense and aspect primarily in two words: a Verb, and an Auxiliary. Other words, such as Modal Particles, adverbial nominals, may contribute, but the interpretation of the Verbal inflexions (2.5) in concert with the Auxiliary "bases"(2.7.1) forms a separable subsystem. See Hale, 1974:1-2.

The following table shows which of the four Auxiliary bases may combine with each of the three primary Verbal inflexions, and indicates the meaning of each combination. The meaning of all the Verbal inflexions in the absence of an Auxiliary base is also indicated.

AUX base	NonPast	Past	Irrealis
none	immediate future	past definite, past perfect	past counterfactual (in conditionals)
<u>ka</u>	present	---	---
<u>lpa</u>	---	past imperfect	present unaccomplished
<u>kapi</u>	general future	---	past counterfactual
<u>kala</u>	(with <u>yungu</u> ) usitative	narrative past, past usitative	--- (? past counterfactual)

(For some speakers, kala extends to usages of lpa)

If there is a time word in the sentence, then kapi is not required with the NPast for a 'general future' interpretation. On the difference between a sentence with kapi and without, see Granites, 1976:7.

Particular combinations of the above bases with some of the possible pre-base elements (2.7.1) have special meanings:

<u>kajika</u>	potential	} (in combination with NPast)
<u>kalaka</u>	admonitive	
<u>kujaka</u>	present presentational	

On kaji vs. kaji-lpa, see Granites, 1976:21.

The other inflexions (Present Presentational, Imperative, and Immediate Future) do not occur with an Auxiliary base. The Imperative does not occur with the pre-bases kula, kuja, or kaji.

Evaluation associates the (individual) nominal expressions with the predicate argument positions of the governing category containing them. To do this, it crucially uses case information. It matches the case of a nominal expression (as displayed in its categorial signature) with the "case label" of an argument position that is present in the "linking register" of that predicate. (See the introduction to Chapter 6, and Hale, 1979:34, 38, 45.) This process has itself been called "linking", or "alignment" (Hale, 1979:45), or "nominal verbal association". In this work I use the term "association" or Evaluation, and reserve "linking" for different processes, discussed in Chapter 6.

#### Evaluation

Evaluate an argument position, in the linking register of a governing predicate, with an N-based (possibly non-terminal, or merged) expression, that has a "matching" case in its categorial signature.

See Chapter 6 for a definition of "matching" as used here. For all case labels except ABS, matching is simply identity; and the case label ABS is taken as matching any N (but no CASE or ARG). Example:

Maliki-patu-rna-jana nya-ngu.  
 dog-Plural-I-them see-Past  
 'I saw the dogs.' (from 7.3.1)

The linking register of the verb is 'ERG see ABS'. The expression maliki is an N (not a CASE or ARG), and it is governed by nya-nyi in the simple structure

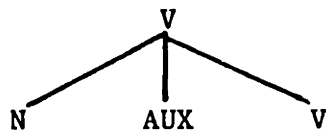

that this sentence may be the terminal string of. Hence maliki may directly evaluate the ABS position of nya-nyi; and at this intermediate stage a semantic expression for " --- see the dogs" is formed. The following condition may be placed on Evaluation:

There may be no more than one expression directly evaluating

any given argument-position. (For the purposes of this condition, at least, a controlled argument position counts as a directly evaluated argument position).

It is envisaged that this condition will not require stipulation just for Warlpiri, but rather will follow from general principles of a theory of interpretation.

In a large class of sentences, it is not crucial that the condition apply, in fact. For, if two nominals, for instance, were to evaluate the same argument-position of a verb, the interpretation would be the same (presumably) as if the two nominals had merged prior to the attempt at evaluation. This may be illustrated by the sentence:

(21) Kurdu-jarra-rlu ka-pala wajili-pi-nyi maliki wita-jarra-rlu.  
 child-Dual-Erg Pres-33 chase-NPast dog small-Dual-Erg

(a) 'The two small children are chasing the dog.'

(b) 'The two children are chasing the dog, and they're small.'

The reading (a) would be obtained by Merging kurdu-jarra-rlu and wita-jarra-rlu (which is possible, since they have identical categorial signatures N-Dual-Erg), to form an expression {kurdu wita} DUAL-ERG which in turn evaluates the ERG-linked argument-position of 'ERG chase ABS'. This reading could just as well have been obtained by doing the merger after the evaluation (not caring for the restriction imposed above).

Reading (b), on the other hand, results from evaluating the ERG-linked argument position (subject) of 'ERG chase ABS' just with the expression kurdu-jarra-rlu. The other ERG-marked expression, wita-jarra-rlu, is associated with the same argument position by Predicational Adjunction (7.3.3) by virtue of the argument position available in the predicate "--- is small".

The second reading, (b), is possible even in the absence of the directly evaluating nominal expression kurdu-jarra-rlu, for there is a general method of interpreting otherwise-unevaluated argument positions:

(22) An argument-position that receives no direct Evaluation is interpreted as "3rd person singular definite"<sup>1</sup>. (For

---

<sup>1</sup>Contrast with Hale's, 1979:31 "Completion of Labelling", which does the same work but in a different part of the grammar, viz. prior to Merger.

the purposes of this rule, a controlled argument-position counts as an evaluated argument position.)

Exceptions:

- (a) a small number of verbs of performance (see 6.2.1) optionally allow an indefinite 3rd person interpretation when not otherwise evaluated, with respect to their ABS (object) argument-position.
- (b) Generic propositions allow a non-specific reading of a non-evaluated argument-position.

Note that English the has properties quite similar to the definite interpretation given by the rule (22). Normally the is 'definite', but there are non-specific readings of the exceptional types (a) (John is playing the piano) and (b) (The beaver builds dams).

#### 7.6 ORDER-DEPENDENT PROCESSES

The processes considered in sub-sections 3.1-3.4 have not taken account of the relative order of the elements that enter into the structural description of the rules. This reflects the freedom of word-order in Warlpiri -- order is relevant for semantic interpretation processes so far discussed only insofar as a string of words has been grouped together into one sentence expression.

However, there are processes which do make direct use of the linear order of words.

One of these has been discussed in detail: the processes of "Incorporation" and "infinitival Bracketing" which motivate the Labelling Rules of 5.4.1-2, and, group relatively unmarked words together with a "head" to their right.

In this section I mention some other processes dependent on linear order of words. They are of a different character from Incorporation, and Merger, in that they do not proceed by comparing categorial signatures for similarity. Rather they interpret an expression in a manner dependent on what expressions are adjacent (7.6.3), and whether the expression is sentence-initial or -final (7.6.1, 7.6.2).



## 7.6.1 INFINITIVAL COMPLEMENTS

## 7.6.1.1 OBVIATIVE COMPLEMENT SUBJECT

In certain obviative infinitive complements, with no argument shared between the main verb and the complement, both the subject and non-subject argument-positions of the Infinitive may be filled by (overt) Nominals. In the instance of the obviative complementiser rlarni, the complement subject appears in the Dative case, at least for older speakers. An example is:

- (23) Ngarrka-ngku ka karli jarnti-rni -- karnta-ku kurdu-ku  
 man-Erg Pres bmg trim-NPast woman-Dat child-Dat  
 miyi yi-nja-rlarni.  
 food give-Inf-Obv  
 'The man is trimming the boomerang, while the woman is giving  
 food to the child.' (Hale, 1978:14)

It is reported that some speakers unambiguously interpret karnta-ku as the subject of "give" in this sentence, and do not allow a reading with kurdu-ku as subject of "give". (Younger speakers tend not to allow the given reading: they proffer an interpretation in which karnta-ku kurdu-ku is taken together as the indirect object of "give", i.e. "to the female child".)

The interpretation rule for speakers who allow the supplied reading is:

In an Obviative Infinitive complement, the subject of the Infinitive, if expressed at all, must be the first of the Dative Arguments preceding the Infinitive.

(There may well be a superior formulation of this rule. It is difficult to investigate given the competing interpretations.) Thus, consider the following sentences, which differ mainly in the order of words in the infinitive complement:

- (24) Ngarrka-ngku ka karli jarnti-rni --  
 man -Erg Pres bmg trim-NPast  
 (a) kurdu-ku maliki wajili-pi-nja-rlarni,  
 child-Dat dog chase- Inf-Obv Comp  
 (b) wajili-pi-nja-rlarni maliki-rlarni kurdu-ku.

(c) kurdu-ku wajili-pi-nja-rlarni maliki-rlarni.

(d) maliki wajili-pi-nja-rlarni kurdu-ku.

(e) wajili-pi-nja-rlarni kurdu-ku maliki-rlarni.

(Hale, 1978:13, and commentary from Laughren, p.c.)

Versions (a), and possibly (c), have, for some (older?) speakers the reading 'The man is trimming the boomerang, while the child is chasing the dog'. The subject kurdu-ku of wajilipinja must precede the object (maliki) (Hale, 1978:13), and is perhaps also required to be the first word of the complement.

All speakers, however, are able to provide another, uniform, interpretation for versions (a)-(e), viz. 'The man is trimming the boomerang, while [someone] is chasing the dog for the child'. The following is a finite paraphrase of the generally available reading:

- (25) Ngarrka-ngku ka karli jarnti-rni, yi-ka-rla yapa-kari-  
 man-Erg Pres bmg trim-NPast Cusal-Pres-Dat person-another-  
 rli wajili-pi-nyi maliki kurdu-ku.  
 Erg chase-NPast dog child-Dat  
 'The man is trimming the boomerang, while the other person is  
 chasing the dog for the child.'

For some (younger?) speakers, the infinitival subject is expressed with an Ergative rather than a Dative in the Obviative Complement:

- (26) Ngarrka-ngku ka karli jarnti-rni, kurdu-ngku maliki wajili-pi-nja-  
 rlarni.  
 (ngku 'Ergative', otherwise as for (24)(a)).

#### 7.6.1.2 INFINITIVE COMPLEMENT OBJECT

The general rules of 5.4 allow a Nominal interpreted with an Infinitive to precede the Infinitive and lack a complementiser, provided no non-complement words intervene. The Infinitival Labelling rule of 5.4.2 accounts for this. A word of an Infinitive complement may also follow the Infinitive (or occur removed from the Infinitive) provided that it bears a complementiser which may "merge" with an Infinitival word bearing a similar (usually identical) suffixed

Complementiser (by the rule of Complement Merger, 7.2 (9)). But the order (a) is in general ungrammatical;

- (a) INF-COMP N-COMP AUX ...
- (b) N(-COMP) INF-COMP AUX ...

The order (b) is the only grammatical one, as is dictated by the rules of AUX-placement (5.6).

However, the requirement on Complement Merger that the Nominal bear a Complementiser may be relaxed in a special situation. This occurs when the two words are sentence-final, as in this textual example:

- (27) Nyanungu-rlu-jana ngarru-rnu -- ngapa-puru -- ya-ni-nja-ku  
 he - Erg -them tell-Past rain-while go-Inf-Purp  
 ngurra-kurra-lku.  
 home-All-then  
 'He told them, since it was raining, to go home then.'

(Hale, 1979:12)

Some speakers reject this sentence, however, and prefer to mark the word of the complement with Complementiser. Thus they replace the final word of (27) with ngurra-kurra-ku (home-All-Purp).

A possible analysis of this phenomenon is that the final nominal when lacking a Complementiser, is syntactically set off from the preceding sentence, even though intonationally incorporated.

#### 7.6.2 INTERROGATIVE WORDS

The Warlpiri interrogatives are:

Nominals:	ngana ~ nyana (H)	'who'
	nyiya ~ nyayi (H)	'what'
	nyiya-ku	'why'
	nyarrpa	'how'
	nyarrpara	'which, where'
	nyangurla	'when'
	nyangurlarnu	'which (what, who)'
	nyajangu	'what ones, how many'
	nyajanguku	'how many times, how many days'

Verbs:           nyarrpa-jarri-mi    'ABS do what'  
                   nyarrpa-ma-ni        'ERG do what to ABS'

Some of the nominals may also be used as a determiner, and may Incorporate or Merge with a non-interrogative nominal. These are; ngana, nyiya, nyangurlarnu and nyajangu. (A related determiner is nganayi 'whats-a-name'.)

The interrogative use of these words subject to an order restriction -- "the question word in a content question appears in "initial position" (Hale, 1978:75). This is so whether it is a Nominal (or Case or Argument based on a nominal), or a Verb, so there is no sense in which the initial position is associated in this way with a particular syntactic category.

And it is often possible to assign an interpretation to these words when they are not sentence initial. This occurs in the context of a negative (typically, the Neg Auxiliary Complementiser, kula), and the indefinite enclitic puka, as in the following examples:

(28) Kula-ka   ngana-ngku marda-rni   puku nyampu.  
       Neg-Pres who-Erg    have-NPast book this  
       'No-one has the book.'

(29) Kapu marlajarra   ya-ni-rni           ngana-puka, kaji Japanangka-  
       Fut empty handed go-NPast-hither who-even    if   (name)-  
       wana            ya-ni    wirlinyi.  
       Perlative go-NPast hunting  
       'Whoever Japanangka goes hunting with will come back empty-  
       handed.'

Furthermore, it is weakly possible to assign a reading to an non-initial interrogative outside of these "affective" contexts, either indefinite:

(30) ?Puku ka    marda-rni   ngana-ngku.  
       book Pres have-NPast who-Erg  
       'Someone has the book.'

or interrogative?

(31) ?Ngampurrpa nyina-mi ka-npa nyiya-ku?  
       desirous   be-NPast Pres-you what-Dat  
       'What do you want?; You want something?'



(33) (b) \*Wangka-ja kula-rna.

(c) Ngaju kula-rna wangka-ja.

I Neg-I speak-Past

(d) \*Wangka-ja kula-rna ngaju.

(e) \*Ngana kula wangka-ja?

The following example shows a typical indefinite reading in the scope of kula:

(34) Kapi-rna-ju janyungu wuruly-(y)irra-ni, kula-ju-lu yapa-ngku  
Fut-I-me tobacco seclusion-put-NPast Neg-me-they person-Frg  
jurnta-ma-ni.  
away-take-NPast

'I'm going to hide my tobacco so nobody will take it from me.'

(Hale, 1959:332)

(ii) Preverbs

This "scopal" phenomenon extends to a Preverb with a negative element in its meaning, though this area of Warlpiri is not well understood. Thus, contrast (35)(a) with (b):

(35) (a) Puta-rna nya-ngu. 'I saw some of it.'

-I see-Past

(b) Nya-ngu-rna puta. 'I saw it somemore, again.'

see-Past-I

Puta is a 'Partitive' Preverb (2.6.4.1); its flexibility of combination with nyangu falls under the discussion of 2.6.5. The general semantic effect of the relative order of Preverb and Verb has not been investigated.

(ii) Enclitic lku

The temporal enclitic lku 'now, and then' has a variable scope, which can be just the word to which it is encliticised, or perhaps the whole sentence in which it occurs. When encliticised to a Nominal at the end of a sentence, it prevents the nominal from directly evaluating an argument position of a preceding predicate, but restricts it to being a Predicational Adjunct, as in:

(36) Wati-rna nya-ngu murrumurru-lku.

man-I see-Past sick-then

'I saw the man and he was sick.'

≠ \*'I saw the sick man.'

It is as if murrumurru-lku here were a separate minimal sentence added to the sentence wati-rna nyangu. Note the presence of lku with similar effect in 7.6.1.2 (27); and note Hale's, 1979:63n8 suggestion that lku's behaviour "is properly defined within the 'punctuation' component".

#### (iv) Modal Particles

Consider the following typical usages of kulanganta 'counterfactual afterthought':

(37) Kulanganta-kapi-rna wawirri panti-ka-rla, (kala lawa).

Counterfactual-Fut-I kangaroo spear-Irr but no

'I thought I was going to spear the kangaroo, but I didn't.'

or: Kulanganta-rna wawirri pantu-rnu, kala lawa.

Counterfactual-I kangaroo spear-Past but no

'I thought I (actually) speared the kangaroo, but no!'

The above two sentences exhibit "sentence scope", but the following usage shows kulanganta with scope just over an immediately following nominal. Further, the nominal is effectively set off from the preceding sentence (cf. lku, (iii) above), and must have a Predicational Adjunct Reading: ngaljipanu-ku cannot be merged with warlkurru-ku.

(38) Warlkurru-rlu marda-nyanu murul-paka-rnu, nyurulypa-rlu-ja

axe-Erg maybe-Refl lop-strike-Past naughty-Erg-Assertive

ngarra -- yi-ka-rla nyurulypa rdirrji-ni warlkurru-ku,

M-Part Caus-Pres-Dat naughty grab-NPast axe-Dat

kulanganta ngaljipanu-ku. Ngula-ngku-nyanu rdawirn-paka-rnu.

deceptively good-Dat that-Erg-Refl cut off-Past

'Maybe he lopped it (his finger) off with the axe, naughty fellow -- since the naughty fellow grabs for the axe, as if it would restrain itself (lit. as if it(axe) were responsible for its own acting). He cut it off (himself) with that.'

(Hale, 1966; M. Connell, p.1)

Similarly, marda 'Potential, maybe' is a Modal Particle which may have sentence scope and typically occurs in "2nd position", as in:

Kapi marda wanti-mi ngapa 'It might rain.'  
 Fut maybe fall-NPast rain (Hale,1974:16)

And marda may have scope over the word to its immediate left. Consider the following pair of sentences, discussed by Granites, 1976:12-13, and the rough translations highlighting the difference in meaning:

- (a) Kurdu marda wanti-ja 'Maybe it was a child that fell.'  
 child maybe fall-Past
- (b) Wanti-ja marda kurdu 'Maybe what happened to the child was  
 fall-Past maybe child that it fell.'

### 7.7 RELATIVE CLAUSES

Syntactically, relative clauses in Warlpiri are distinguished from "main" clauses only in the presence of "Relative Complementiser" in the Auxiliary. See the Auxiliary template, 2.7.1. The first item in the template may be:

kaji 'uninstantiated Relative time Relative, conditional'  
 kuja ~ ngula 'instantiated Relative'  
 yungu ~ yinga 'motivational, causal, rational, Purposive'

A sentence containing this Auxiliary is of the "relative" type, and is syntactically on a par with other sentences of "non-relative" or "main" type.

The account of Warlpiri syntax in this work assumes that "relative" sentences are separate sentences from the "main" sentences which they might follow (or precede). This is justified not only by the parallel syntax and interpretive processes in the two types of sentence, but also by the observation that, just as two "main" sentences do not interpenetrate one another, so a "relative" sentence does not occur "inside" another sentence, but rather is "adjoined" (syntactically) to it. Hence the account of Warlpiri relative clauses in Hale, 1976b. (Note also the sentence with two relative clauses quoted by Dixon, 1976:4.)

Hale, 1976b discusses the syntactic integration of the relative clause into the main clause, but also entertains the alternate view:



that the strictly grammatical responsibility of a general theory of Walbiri linguistic competence ends with the definition of well-formed adjoined clauses and that what I have been referring to as the 'interpretation' of adjoined relatives is really a matter of usage. (Hale,1976b:86)

It is this view that I am adopting here, with the understanding that the "matter of usage" includes the theory of inter-sentential anaphoric relations. In the "N-relative" interpretation commonly accorded a sentence with the kuja 'instantiated Rel' complementiser in its Auxiliary, the sentence containing the kuja Auxiliary may have a "missing argument", i.e. an argument position not necessarily evaluated by a nominal expression, but only by an pronominal clitic (if that). This argument position may be interpreted as coreferent with an argument-position in an adjacent sentence, in a "zero-anaphora" manner -- see 7.3 (ii)(a), (v). Alternatively the evaluation of the argument-position in question may be solely by an anaphoric nominal, 7.3(i), which in turn is interpreted as coreferent with an argument of an adjacent sentence.

This view also fits with the accessibility data reported by Hale, 1976b:98 :

In Walbiri there are no apparent limits on the grammatical functions of NP<sub>j</sub> within the immediately subordinate clause, but I have not as yet been able to determine the total range of structural positions which NP<sub>j</sub> may occupy, though I doubt they differ in any essential way from the positions which any anaphoric element, construed with an antecedent in the main clause, may occupy.

(Here "NP<sub>j</sub>" refers to the argument position of the Relative clause. Note that "anaphoric element" is used here to mean just a definite determiner nominal, cf. in 7.3(i).)

Two further properties of Warlpiri relative clauses fit naturally with this view adopted in this work: (a) the "missing argument", in an N-Relative interpretation, is generally in the clause with the Relative Complementiser, but may instead be in the "main" clause; (b) the "Relative" and "Main" clauses may have no coreferential arguments at all -- see, for example, Hale, 1976b:87(24).

## APPENDIX: WARLPIRI VERB ROOTS

The following list contains the verb roots occurring in Hale, 1974 or in the card file of the Warlpiri Dictionary Project. The roots are arranged by conjugation (paradigm class -- see 2.5), and, within each conjugation, alphabetically.

The gloss assigned to each root serves to convey the basic ideas expressed by the verb, and to present the "case frame" ("linking register" -- see chapter 6) of the root. The reader is cautioned that many senses of the root are often omitted, and that the sense provided in the gloss may be too narrow or too wide when compared with a detailed account of the root's meaning. Furthermore, all complex verb themes (Preverb-Verb combinations -- see 2.6) are omitted, even though a number of them are more common than some of the roots in this list, and often have idiosyncratic properties. In the great majority of cases, however, the complex theme is a hyponym of the root contained in it, and has the same case-frame. I have identified a number of "homophonous roots" in the list, so as to reduce the unpredictability of complex themes containing those roots (e.g. nga-rni, ma-ni).

V1

janka-mi	'1. ABS burn; 2. ERG burn ABS'
japirdi-mi	'ABS threaten DAT (behind back)'
jarnti-mi	'ABS limp, walk in lame manner'
-jarri-mi	'Inchoative' (always in combination)
jija-mi	'ABS be defeated by DAT, ABS succumb to DAT'
jirrti-mi (L)	'ABS(tongue) hang out, poke out'
jiti-mi	'ABS descend, dismount'
kampa-mi	'1. ABS burn; 2. ERG burn ABS'
kapati-mi	'ABS be uneasy in DAT(place, situation)'
karla-mi	'ERG dig up ABS(e.g. yams)'
karli-mi	'ABS flow'
karlpi-mi	'ERC(temperature extreme) cause ABS to suffer'
karrri-mi	'ABS stand, be vertical'
karrka-mi	'ABS proceed'
kawarirri-mi	'ABS wander (as blind, or searching)'
kulpa-mi	'ABS return to origin'

irri-mi	'ABS swell'
ngarlarri-mi	'ABS laugh'
ngurntirri-mi	'ABS grumble at, scold DAT' (also ngurnturri-mi)
nguna-mi	'ABS lie, recline'
nyanjayalpi-mi	'ERG prepare, or find prepared, ABS(food) after hunting, work' (recent loan)
nyina-mi	'ABS sit, be'
nyurla-mi	'ERG knead ABS'
pali-mi	'ABS die, (fire) go out'
papi-mi	'ABS ignite, flare up'
-para-mi (W)	'ERG follow ABS' (?) (only in combinations)
pardi-mi	'1. ABS emerge, arise; 2. ABS(plant) grow'
parnka-mi	'ABS run'
parntarri-mi	'ABS crouch'
parnti-mi	'ABS smell, give off odour'
pura-mi	'ERG follow ABS'
purla-mi	'ABS shout (to DAT)'
purra-mi	'ERG burn, cook ABS'
rdipi-mi	'1. ABS encounter DAT; 2. ABS gather'
tirlpi-mi	'ERG trim ABS, flake by percussion'
turlka-mi	'ERG pinch ABS' (also tulyka-mi)
wangka-mi	'ABS speak (to DAT), make characteristic noise'
wanti-mi	'ABS fall, drop'
wapa-mi	'ABS move about, go'
wapirri-mi	'ABS conceal, cover up DAT'
waraparmpi-mi	'1. ABS sing out; 2. ABS announce, mention name of DAT'
wipi-mi	'ABS radiate out'
wirnpirli-mi	'ABS whistle'
wirnti-mi	'ABS(esp. women) dance' (also yirnti-mi)
yampi-mi	'1. ERG leave ABS alone; 2. ERG reject ABS'
yarnka-mi	'1. ABS start on journey; 2. ABS grab (for) DAT'
yilya-mi	'1. ERG send away ABS; 2. ERG send ABS to DAT'
yirdi-mi (?)	'ABS be frightened' (?) (only in combination)
yuka-mi	'1. ABS enter; 2. ABS arrive; 3. ABS(sun, etc) set'
yula-mi	'1. ABS cry, howl; 2. ABS be sad, express grief'

yulka-mi	'ABS cherish, love DAT'
yurirri-mi	'ABS move, stir' (also yururri-mi)
<u>V2</u>	
jaja-rni	'ERG eat off of, feed from ABS'
jampi-rni	'ERG lick ABS'
japi-rni	'ERG ask ABS(person) about DAT'
jarnti-rni	'ERG scrape, trim, shave ABS'
-jirri-rni	'ERG act forcefully on ABS'(?) (only in combinations)
jiti-rni	'1. ERG tease, badger ABS; 2. (L) ERG play ABS(guitar)'
kardi-rni	'ERG scoop up ABS(water) in container'
kati-rni	'ERG weigh down on ABS'
kiji-rni	'1. ERG throw, cause to fall ABS; 2. ERG put ABS(decoration) on DAT(person)'
kipi-rni	'ERG winnow ABS' (kirrpi-rni (H))
kulpa-rni	'use' ?
larrji-rni	'ERG scratch ABS'
luwa-rni	'1. ERG hit ABS with missile; 2. ERG spin ABS(hair) into string'
maja-rni	'1. ERG straighten ABS(implement); 2. ERG stretch self to relieve cramp'
mapa-rni	'ERG rub, anoint ABS'
marda-rni	'ERG hold, have ABS'
marnpi-rni	'ERG touch ABS' (also parnpi-rni)
mati-rni	'ABS go in procession'
mila-rni	'ERG choose (best one of) ABS'
mirri-rni	'ERG erase, efface ABS'
ngaja-rni	'ERG void ABS(bodily waste, egg, baby)
nganti-rni	'ERG build, erect ABS'
ngarlki-rni	'ERG block ABS(weapon)'
ngarri-rni	'1. ERG tell ABS(message, order) to DAT; 2. ERG scold ABS; 3. ERG call ABS "ABS"'
ngarrmi-rni	'ERG increase ABS(sp.) by ritual'
nyunji-rni	'ERG kiss ABS'

paja-rni	'ERG taste, savour ABS'
paji-rni	'ERG cut ABS'
paka-rni	'ERG strike, hit, chop ABS'
pangi-rni	'ERG dig, scratch deeply ABS'
panti-rni	'1. ERG spear, poke, pierce ABS; 2. ERG(sun) shine on ABS'
parda-rni	'ABS wait for DAT'
parlji-rni	'ERG wash ABS'
parnta-rni	'ERG withdraw ABS from fire'
-parri-rni	'ERG act on ABS' (?) (only in combinations)
payi-rni	'ERG ask ABS(person) about DAT'
-pirri-rni	(only in wayi-pirri-rni 'ERG pick up ABS..')
pirrki-rni	'ERG trim, make ABS'
punta-rni	'ERG take ABS away from DAT'
rdanpa-rni	'ABS accompany DAT'
rdirrji-rni	'ABS start a fight'
walji-rni	'ERG pluck ABS'
wanja-rni	'ERG takes ABS(sip of drink) off DAT'
wardi-rni	'ERG straighten ABS(implement)'
wari-rni	'ERG tie ABS' (also wayi-rni)
warri-rni	'ERG seek DAT' (also wayi-rni)
warrka-rni	'1.ABS climb, mount; 2. ERG ride ABS(horse)'
winji-rni	'ERG pour ABS'
wuurlparra-rni	'ERG flay, dehair ABS(as kangaroo, for cooking)'
yaja-rni	'ERG enlist, go to get help of ABS'
yarlki-rni	'ERG bite ABS'
yarli-rni	'ERG(rain) wet, soak ABS'
yarrpi-rni	'ERG build ABS(fire)'
yilyiwirrpri-rni	'ERG slurp up ABS(hot drink)'
yingki-rni	'ERG set fire to ABS'
yipi-rni	'ERG pick out ABS(pimple)'
yirnti-rni	'ERG turn over, capsize ABS'
yirra-rni	'1. ERG place ABS at LOC,ALL; 2. ERG create ABS(design) on DAT'
yirrpri-rni	'ERG cause ABS to enter, insert'

yunpa-rni 'ERG sing ABS(song)'  
 yurupa-rni 'ERG grind ABS(seeds)'

V3

ka-nyi 'ERG transport ABS (to DAT)'  
 nya-nyi '1. ERG see ABS; 2. ERG look about for DAT'  
 pi-nyi 'ERG act on ABS, hit, bite, damage, kill'  
 yi-nyi 'ERG give ABS to DAT'  
 mapara-nyi (W) 'ERG rub, anoint ABS' (cf. mapa-rni)  
 palyarri-nyi (H)  
 jurdurri-nyi 'ERG cover up ABS' (cf. jutu-pi-nyi)  
 yurlpara-nyi 'ERG send ABS' (cf. yilya-mi)

V4

nga-rni '1. ERG ingest ABS, eat, drink;  
 2. ABS move (only in combinations)'

V5

ji-ni 'ERG scold ABS (over ELATIVE)'  
 ma-ni '1. ERG get, take ABS;  
 2. ERG take ABS(guts) out of DAT(carass);  
 3. ABS make noise (only in combinations);  
 4. Causative (only in combinations)'  
 ya-ni 'ABS go'  
 -nji-ni 'Inceptive' (see 2.5)

## BIBLIOGRAPHY

PART I: Works chiefly concerned with Warlpiri

- Carrier, Jill 1976. Grammatical relations in Warlpiri. 60pp. Cambridge, Mass.:M.I.T.(Spring).
- Granites, Robin Japanangka 1976. Short essays in Warlpiri linguistics (in Warlpiri and English). Mimeo., 22pp. Cambridge, Mass.:M.I.T., January.
- Hale, Kenneth L. 1959. WalpIRi field notes. Yuendumu, etc. [Rewritten in practical orthography, 1979].
- - - - - 1959b. Introduction to Wailbry Domains and Selection. 90pp. Typescript.
- - - - - 1966. WalpIRi field notes. Ms., Yuendumu etc. [Copies deposited at Yuendumu, and A.I.A.S., Canberra.]
- - - - - 1967. Lessons in Walbiri, I-VII. Mimeo., 58pp. Cambridge, Mass.:M.I.T. [Prepared with the assistance of Sam Japangadi Johnson.]
- - - - - 1967-68. Preliminary remarks on Walbiri grammar. I 1967, II 1968. Mimeo., 101pp. Cambridge, Mass.:M.I.T.
- - - - - 1969. Walbiri conjugations. Mimeo., 14pp. Cambridge, Mass.: M.I.T.
- - - - - 1972. Walbiri kinship problem. 15pp. Cambridge, Mass.:M.I.T.
- - - - - 1973a. "Person marking in Walbiri", 308-344 in A Festschrift for Morris Halle, ed. by Stephen R. Anderson & Paul Kiparsky. New York: Holt, Rinehart & Winston, Inc.
- - - - - 1973b. "Deep-surface canonical disparities in relation to analysis and change: an Australian example", 401-458 in Current Trends in Linguistics, Vol. 11, ed. by Thomas Sebeok. The Hague: Mouton.
- - - - - 1973c. Walbiri data, I-XIV. Mimeo., separately paginated sections. Cambridge, Mass.: M.I.T.
- - - - - 1974. An elementary dictionary of the Warlpiri language. Mimeo., 97pp. Cambridge, Mass.: M.I.T., May. [Re-issued by Institute for Aboriginal Development, Alice Springs, 1977.]
- - - - - 1975. "Gaps in grammar and culture", 295-315 in Linguistics and Anthropology, in Honor of C.F. Voegelin, ed. by M.D. Kinkade et al. Lisse: Peter de Ridder Press.
- - - - - 1976a. Lessons in Warlpiri, I-VIII. Mimeo., separately paginated sections. Cambridge, Mass.: M.I.T. January. [Prepared with

- the assistance of Robin Japanangka Granites.]
- - - - - 1976b. Typological sketch of Walbiri. Mimeo., 12pp. Cambridge, Mass.: M.I.T.
- - - - - 1976c. "The adjoined relative clause in Australia", in Dixon, 1976:78-105.
- - - - - 1976d. "On ergative and locative suffixal alternations in Australian languages", in Dixon, 1976:414-17.
- - - - - 1977. Elementary remarks on Walbiri orthography, phonology and allomorphy. 34pp. Cambridge, Mass.: M.I.T.
- - - - - 1978. The essential features of Walbiri main clauses. Mimeo., 129pp. Cambridge, Mass.
- - - - - 1979. On the position of Walbiri in a typology of the base. 79pp. Mimeo. Cambridge, Mass.: M.I.T.
- Jagst, Lothar 1975. "Ngardilpa (Warlpiri) Phonology. (Language of the Warnayaka tribe, a subtribe of the Warlpiri tribe)", Papers in Australian Linguistics, No. 8. Pacific Linguistics Series A, No. 39, 21-57. Canberra: Research School of Pacific Studies, A.N.U.
- Kendon, Adam 1978. Yuendumu Sign Language project. Memorandum I, 35pp. Canberra: Research School of Pacific Studies, A.N.U.
- Laughren, Mary 1977. Pronouns in Warlpiri and the category of number. Mimeo., 18pp., Department of Education, Yuendumu.
- - - - - 1978. "Directional terminology in Warlpiri, a Central Australian language", Working Papers in Language and Linguistics, No.8. Launceston, Tas.: Tasmanian College of Advanced Education.
- - - - - forthcoming. "Warlpiri kinship structure", Language and Kinship in Australia, ed. by Jeffrey Heath.
- Meggitt, Mervyn J. 1962. Desert People. A study of the Walbiri Aborigines of Central Australia. Sydney: Angus & Robertson. (Chicago and London: The University of Chicago Press, 1965.)
- Nash, David 1979. "Warlpiri vowel assimilations", Safir (ed.), 1979:12-24.
- Steriade, Donca 1979. "The input representations to Warlpiri's vowel assimilation rules", Appendix, pp.43-48 to "Vowel harmony in Khalkha Mongolian", in Safir ed., 1979:25-50.
- "Warlpiri Lesson Summaries" (13 lessons) 42pp. Alice Springs, N.T.: Institute for Aboriginal Development. "Prepared by I.A.D. and Yuendumu staff" Accompanied by "Aboriginal Language Learning



Cassettes", 11 cassettes covering 13 lessons, and songs.

PART II: OTHER WORKS

- Abraham, Werner (ed.) 1978. Valence, Semantic Case, and Grammatical Relations. (Papers prepared for the Working Group "Valence and Semantic Case" 12th International Congress of Linguists, University of Vienna, Austria, August 29 to September 3, 1977.) Studies in Language Companion Series, Vol. 1. Amsterdam: John Benjamins B.V.
- Ades, Anthony E. & Mark Steedman 1979. On word order. Mimeo., 67pp.
- Anderson, John M. 1976. "On serialisation in English syntax", Ludwigsburg Studies in Language and Linguistics (LSLL 1), ed. by R.O.U. Strauch. Ludwigsburg.
- Aoun, Youssef 1980. A note on filters and double projections. Ms., 10pp. Cambridge, Mass.: M.I.T., April.
- Austin, Peter 1979. Transitivity and cognate object constructions in Australian languages. Ms., 15pp. To appear in Studies in Transitivity, ed. by S.A. Thompson & P. Hopper.
- - - - - 1980. "Switch-reference in Australian languages", in Studies of Switch-Reference, ed. by Pamela Munro, U.C.L.A. Working Papers in Syntax No.8. Los Angeles, Calif.: U.C.L.A. To appear in Language (revised).
- Bach, Emmon 1975. "Order in Base Structure", 307-43 in Word Order and Word Order Change, ed. by Charles Li. Austin and London: University of Texas Press.
- Blake, Barry J. 1977. Case marking in Australian languages. Canberra: A.I.A.S.
- Boas, Hans Ulrich 1975. Syntactic generalizations and linear order in generative transformational grammar. Tübinger Beiträge zur Linguistik 56. Tübingen: G. Narr.
- Bouchard, Denis 1979. Conjectures on a context free grammar for natural languages. 44pp. Université de Montréal & M.I.T.
- Capell, Arthur 1956. A New Approach to Australian Linguistics. Oceania Linguistic Monograph 1. Sydney: Oceania (The University of Sydney).

- Carrier, Jill 1979. The Interaction of Morphological and Phonological Rules in Tagalog. PhD. dissertation, M.I.T. September.
- Carter, Richard J. 1977. "Some Linking Regularities" *Recherches Linguistiques* 3-4. Paris: Université de Vincennes.
- Chadwick, Neil 1975. A descriptive study of the Djingili language. Canberra: A.I.A.S.
- Chafe, Wallace 1970. *Meaning and the Structure of Language*. Chicago: University of Chicago Press.
- Chomsky, Noam 1965. *Aspects of the Theory of Syntax*, Cambridge, Mass.: M.I.T. Press.
- - - - - 1980. "On binding", *Linguistic Inquiry* 11.1 (Winter) 1-46. Cambridge, Mass.: M.I.T. Press.
- - - - - & Morris Halle 1968. *The Sound Pattern of English*. New York etc: Harper & Row.
- Clements, George N. 1977a. "The autosegmental treatment of vowel harmony", 111-119 in *Phonologica* 1976. (Akten der dritten Internationalen Phonologie-Tagung, Wien, 1-4 September 1976.) ed. by Wolfgang U. Dressler and Oskar E. Pfeiffer. = *Innsbrucker Beiträge zur Sprachwissenschaft*, 19.
- - - - - 1977b. "Neutral vowels in Hungarian vowel harmony: an autosegmental interpretation", 49-64 in Judy Kegl, David Nash and Annie Zaenen (eds.) *Proceedings of the Seventh Annual Meeting of the North Eastern Linguistic Society, (NELS VII)*. Cambridge, Mass.: M.I.T., January.
- Costandi, [A-S] John Josef 1975. "Homonymic ambiguity, pronominal systems and the clitic-lem in modular linguistics", *Berkeley Linguistics Society, Proceedings*, Vol. 1, 100-122.
- Curry, Haskell B. 1961. "Some logical aspects of grammatical structure " 56-68 in *Structure of Language and its Mathematical Aspects*. *Proceedings of the Twelfth symposium in Applied Mathematics*, ed. by R. Jakobson. Providence, R.I.: American Mathematical Society.
- Daneš, Frantisek 1967. "Order of Element and Sentence Intonation", 499-512 in *To Honor Roman Jakobson*. The Hague: Mouton.
- Dixon, R.M.W. 1972. *The Dyirbal Language of North Queensland*. Cambridge Studies in Linguistics, 9. Cambridge, U.K.: Cambridge University Press.

- - - - - (ed.) 1976. *Grammatical Categories in Australian Languages*. Canberra: A.I.A.S. Atlantic Highlands, N.J.; Humanities Press Inc. (Linguistic Series No.22).
- - - - - 1977. *A Grammar of Yidin<sup>y</sup>*. Cambridge Studies in Linguistics 19. Cambridge, U.K.: Cambridge University Press.
- - - - - 1979. "Ergativity", *Language* 55.1, 59-138.
- Donaldson, Tamsin 1980. *A Description of Ngiyambaa: the Language of the Wangaaybuwan People of Central Western New South Wales*. Cambridge, U.K.: Cambridge University Press.
- Dubisson, Colette & Marielle St. Laurent 1979. *Hypothese d'une base W\* pour l'ancien français*. 13pp. U. Quebec à Montréal.
- Edmondson, Jerold A. 1978. "Ergative languages, accessibility hierarchies governing reflexives and questions of formal analysis", in Abraham (ed.) 1978:633-60.
- Fillmore, Charles J. 1968. "The case for case" [0]-88 in *Universals in Linguistic Theory*, ed. by Emmon Bach and R. Harms. New York: Holt, Rinehart & Winston.
- - - - - 1971. "Types of lexical information", in Steinberg & Jakobovits, 1971:370-92.
- Gleason, H.A., Jr. 1964. "The organization of language: a stratificational view", 75-95 in *Report of the Fifteenth Annual Round Table Meeting on Linguistics and Language Studies*, ed. by C.I.J.M. Stuart. Washington, D.C.: Georgetown University Press.
- Greenberg, Joseph H. 1963. "Some universals of grammar with particular reference to the order of meaningful elements", 73-113 in *Universals of Language*, ed. by Joseph Greenberg. Cambridge, Mass. and London: M.I.T. Press.
- Hale, Kenneth L. 1976. "Linguistic autonomy and the linguistics of Carl Voegelin", *Anthropological Linguistics*, March, 120-28.
- - - - - 1980. "Remarks on Japanese phrase structure. Comments on the Papers on Japanese Syntax", 185-203 in *Theoretical Issues in Japanese Linguistics*, M.I.T. Working Papers Vol. 2, ed. by Yukio Otsu and Ann Farmer. Cambridge, Mass.: M.I.T.
- - - - - Laverne Masayeva Jeanne, and Paul Platero 1977. "Three cases of overgeneration", 379-416 in *Formal Syntax*, ed. by Peter W. Culicover, Thomas Wasow and Adrian Akmajian. New York: Academic Press.

- Hall, Barbara 1964. "Review of S.K.Shaumjan and P.A. Soboleva." in  
Language 40:397-410.
- Halle, Morris 1979. Preface, in Safir (ed.), 1979:vi-x.
- Hansen, K.C. & L.E. 1977. Pintupi/Luritja Dictionary. (1st ed. 1974, Summer  
Institute of Linguistics) Alice Springs, N.T.: Institute for Aboriginal  
Development, (2nd ed.)
- - - - - 1978. The Core of Pintupi Grammar. Alice Springs, N.T.:  
Institute for Aboriginal Development.
- Harman, G.H. 1963. "Generative grammars without transformational rules: a  
defence of phrase structure", Language 39:597-616.
- Hayes, Bruce 1980. A Metrical Theory of Stress Rules. PhD. dissertation.  
M.I.T.
- Hetzron, Robert 1975. "Surfacing - from Dependency Relations to Linearity."  
Testi e Studi III, Centro Interfacoltà di Linguistica Teorica e  
Applicata, U. Bologna. Liviana Editrice in Padova.
- Hoard, James E. & Geoffrey N. O'Grady 1976. "Nyangumarda phonology: a  
preliminary report", in Dixon (ed.), 1976:51-77.
- Hudson, Grover 1972a. "Is Deep Structure linear?", 51-77 in Explorations  
in Syntactic Theory, ed. by George Bedell. U.C.L.A. Papers in Syntax  
No.2, July.
- - - - - 1972b. "Why Amharic is not a VSO language",  
Studies in African Linguistics 3.1, March. 127-65.
- Hudson, Joyce 1978. The Core of Walmatjari Grammar. Canberra: A.I.A.S. &  
Atlantic Highlands, N.J.: Humanities Press, Inc.
- Hudson, Richard A. 1976. Arguments for a Non-Transformational Grammar.  
Chicago: Chicago University Press.
- Hyman, Larry M. 1975. Phonology, Theory and Analysis. New York etc: Holt,  
Rinehart and Winston.
- - - - - 1977. "On the nature of linguistic stress", 37-82 in  
Hyman (ed.) Studies in Stress and Accent, Southern California  
Occasional Papers in Linguistics Vol.4.
- Jackendoff, Ray 1977.  $\bar{X}$  Syntax: A Study of Phrase Structure. Linguistic  
Inquiry Monograph Two. Cambridge, Mass.
- Jayaseelan, Karattuparambil A. 1979. "On the role of the empty node in the  
structure-preserving hypothesis" Linguistic Analysis 5.3 (September):  
247-292.

- Keyser, Samuel Jay 1968. "Review of Sven Jacobson: Adverbial positions in English (PhD. Uppsala, Stockholm:1964)" *Language* 44.2.1 (June): 357-374.
- Klavans, Judith L. 1979. "On clitics as words" *Chicago Linguistics Society* 15.
- Klokeid, Terry J. 1978. "Nominal Inflection in Pama-Nyungan" in Abraham (ed.) 1978:577-615.
- Lamb, Sidney M. 1966. *Outline of Stratificational Grammar*. Washington, D.C.: Georgetown University Press.
- Leben, William R. 1978. "The Representation of Tone", 177-219 in *Tone. A Linguistic Survey*, ed. by Victoria A. Fromkin. New York etc: Academic Press.
- Liberman, Mark Y. & Alan Prince 1977. "On stress and linguistic rhythm", *Linguistic Inquiry* 8.2 (Spring), 249-336.
- Lieber, Rochelle 1980. *The Organisation of the Lexicon*. PhD. dissertation, M.I.T.
- Lyons, John 1966. "Towards a "notional" theory of the "parts of speech"", *Journal of Linguistics* 2:209-36.
- Marantz, Alec 1979. *Reduplication: pseudo-problems and para-paradoxes*. December, M.I.T. generals paper.
- - - - - 1980. *Reduplication and C-V skeleta*. 11pp. M.I.T.
- McCawley, James D. 1968. "Concerning the Base Component of a Transformational Grammar", *Foundations of Language* 4:243-69. (Reprinted in *Grammar and Meaning*, 35-58. Taishukan, Tokyo, 1973.)
- Nash, David 1979a. "Yidin<sup>y</sup> stress: a metrical account", *CUNYForum* 7/8 (Spring), 112-30.
- - - - - 1979b. *Preliminary Vocabulary of the Warlmanpa Language, with Grammatical Preface*. Cambridge, Mass., December.
- Ostler, Nicholas D.M. 1979. *Case-Linking. A Theory of Case and Verb Diathesis applied to Classical Sanskrit*. PhD. dissertation, M.I.T.
- Perlmutter, David M. 1971. *Deep and Surface Structure Constraints in Syntax*. New York etc.: Holt, Rinehart and Winston, Inc. (Trans-Atlantic Series in Linguistics).
- Peterson, Thomas H. 1971. "Multi-ordered base structures in generative grammar", *C.L.S.* 7:181-92.
- Rivas, Alberto Mario 1977. *A Theory of Clitics*. PhD. dissertation, M.I.T.

- Ross, John Robert 1967. Constraints on Variables in Syntax. PhD. dissertation, M.I.T.
- Rotenberg, Joel 1978. The Syntax of Phonology. PhD. dissertation, M.I.T.
- Safir, Ken (ed.) 1979. Papers on Syllable Structure, Metrical Structure and Harmony Processes. M.I.T. Working Papers in Linguistics Vol.1. Cambridge, Mass.: M.I.T.
- Sanders, Gerald 1969. Invariant ordering. Indiana University Linguistics Club mimeo. Revised version published, The Hague: Mouton.
- - - - - 1970. "Constraints on constituent ordering" in Papers in Linguistics 2:460-502.
- Shaumjan, S.K. 1964. "Concerning the logical basis of linguistic theory", Proceedings of the Ninth International Congress of Linguists, pp.155-60.
- - - - - & P.A. Soboleva 1963. Aplikativnaja porozhdajushchaja model' i ischislenie transformacij v russkom jazyke. Moscow: Akademii Nauk SSSR
- Simpson, Jane 1980. Ngarluma as a W\* language. March, M.I.T. generals paper.
- Staal, J.F. 1967. Word Order in Sanskrit and Universal Grammar. Dordrecht: D. Reidel.
- Steele, Susan 1975. "On some factors that affect and effect word order", 199-268 in Word Order and Word Order Change, ed. by Charles Li. Austin and London: University of Texas Press.
- Steinberg, Danny D. & Leon A. Jakobovits 1971. Semantics. An interdisciplinary reader in philosophy, linguistics and psychology. Cambridge, U.K.: Cambridge University Press.
- Stewart, Ann Harleman 1976. Graphic Representation of Models in Linguistic Theory. Bloomington and London: Indiana University Press.
- Werth, Paul 1977. "Focus and linear order", paper presented to the Linguistics Society of Great Britain, University College London, November.
- Whitman, John 1979. "Scrambled, Over easy, or Sunny Side Up?" in C.L.S. 15.
- Williams, Edwin 1980. "Predication", in Linguistic Inquiry 11:1 (Winter): 203-238.
- Yngve, V.H. 1960. "A model and an hypothesis for language structure", 444-66 Proceedings of the American Philosophical Society 104.5 (October).
- Zwicky, Arnold N. 1977. "On clitics" Bloomington, Ind: Indiana University Linguistics Club, February. (Abbreviated version in Phonologica, 1976: cf. Clements, 1977a).

## BIOGRAPHICAL NOTE

The author was born on 5 March 1951 at Parkes, N.S.W. He grew up on a farm near Parkes, and attended Parkes Primary and High Schools. In 1969 he was awarded a National Undergraduate Scholarship at the Australian National University, Canberra, where he studied mathematics. Having received B.A.(Hons.) degree, he turned, in 1973, to linguistics at the same university, and with the support of a Commonwealth Postgraduate Course Award completed a two-year M.A. by Coursework degree. From September 1975 he was a Research Assistant in the Department of Linguistics at M.I.T. He took a year's leave in the middle of the doctoral program to attend the L.S.A. Linguistic Institute in Honolulu, and then engage in nine month's field study of the Warlmanpa language of the central Northern Territory, supported by a Rothmans Fellowship. From June to August 1979 he was a consultant to the Central Land Council, Alice Springs, a position he again has from June to September 1980.

His publications are:

- (1979) "Yidiny stress: a metrical account". CUNYForum 7/8(Spring),112-30.  
 (Proceedings of the Ninth Annual Meeting of the North Eastern Linguistics Society, City University of New York, November 1978).
- (1979) "Aborigines and courts in the Northern Territory".  
Legal Service Bulletin 10.4.
- (1979) "Warlpiri vowel assimilations", 12-24 in MIT Working Papers in Linguistics, Vol. 1, ed. by Ken Safir. Cambridge, Mass.: M.I.T.
- (forthcoming) "An etymological note on Warlpiri kurdungurlu", A.I.A.S. Biennial Conference, Symposium on Aboriginal Land Rights, May 1980.
- (forthcoming) A Claim to an Area of Traditional Land by the Warlmanpa, Warlpiri, and Mudbura Traditional Owners. Alice Springs, N.T.: Central Land Council.

and he collaborated in:

- (1977) (with J. Kegl and A. Zaenen, eds.) Proceedings of the Seventh Annual Meeting of the North Eastern Linguistic Society. Cambridge, Mass.