

CREOLE LANGUAGE LIBRARY VOLUME 14

KRIYOL SYNTAX

The Portuguese-based Creole
language of Guinea-Bissau

Alain Kihm



JOHN BENJAMINS PUBLISHING COMPANY

KRIYOL SYNTAX

CREOLE LANGUAGE LIBRARY (CLL)

A companion series to the
"JOURNAL OF PIDGIN & CREOLE LANGUAGES"

Editor: Pieter Muysken (Amsterdam)

Editorial Advisory Board:

Mervyn Alleyne (Kingston, Jamaica)	George Huttar (Dallas)
Norbert Boretzky (Bochum)	Salikoko Mufwene (Chicago)
Lawrence Carrington (Trinidad)	Peter Mühlhäusler (Adelelaide)
Chris Corne (Auckland)	Pieter Seuren (Nijmegen)
Glenn Gilbert (Carbondale, Illinois)	Norval Smith (Amsterdam)
John Holm (New York)	

Volumes in this series will present descriptive and theoretical studies designed to add significantly to our insight in Pidgin and Creole languages.

Volume 14

Alain Kihm

Kriyol Syntax

KRIYOL SYNTAX

THE PORTUGUESE-BASED
CREOLE LANGUAGE OF GUINEA-BISSAU

ALAIN KIHM

JOHN BENJAMINS PUBLISHING COMPANY
Amsterdam/Philadelphia



The paper used in this publication meets the minimum requirements of American National Standard for Information Sciences — Permanence of Paper for Printed Library Materials, ANSI Z39.48-1984.

Library of Congress Cataloging-in-Publication Data

Kihm, Alain.

Kriyol syntax : the Portuguese-based Creole language of Guinea-Bissau / Alain Kihm.
p. cm. -- (Creole language library, ISSN 0920-9026; v. 14)

Includes bibliographical references and index.

1. Crioulo language--Syntax. I. Title. II. Series.

PM7849.G8K54 1994

469.7'996657--dc20

94-13481

ISBN 90 272 5235 1 (Eur.) / 1-55619-168-5 (US) (Hb.; alk. paper)

CIP

© Copyright 1994 - John Benjamins B.V.

No part of this book may be reproduced in any form, by print, photoprint, microfilm, or any other means, without written permission from the publisher.

John Benjamins Publishing Co. · P.O. Box 75577 · 1070 AN Amsterdam · The Netherlands
John Benjamins North America · 821 Bethlehem Pike · Philadelphia, PA 19118 · USA

Table of Contents

Acknowledgments	IX
Abbreviations for sources	X
Map	XI

Chapter 1

Introduction	1
1.1. History	1
1.2. A history of Kriyol: facts and suppositions	3
1.3. The study of Kriyol: what, how, and why?	8
1.4. A phonological sketch of Kriyol	12
1.4.1. Syllabic structure	13
1.4.2. Stress	14
1.4.3. Vowels	14
1.4.4. Consonants	15
1.5. Phonological developments from 16th century Portuguese to Kriyol	16
1.6. Relation with Cape-Verdean Creole	19

Chapter 2

The simple sentence	21
2.1. Introduction	21
2.2. The composition of the predicate	23
2.2.1. Verbal predicates	23
2.2.1.1. Verb morphology	23
2.2.1.2. Verb composition	24
2.2.1.3. Subcategorization types	25
2.2.2. Adjective predicates	34
2.2.3. Noun predicates	37
2.3. Negation	41
2.3.1. The origin of ka	46
2.4. The arguments of the verb	47
2.4.1. Selected subjects of environmental verbs	49
2.4.2. Sentential subjects	50

2.4.3. Double object constructions (DOC)	54
2.4.3.1. Possible origins for DOCs	56
2.4.4. Unaffected(?) objects	57
2.4.5. Argument shifting verbs	64
2.4.6. Subcategorized PPs	67
2.5. Adjoined PPs	67
2.6. Adverbs	72
2.6.1. Local adverbs (including ideophones)	72
2.6.2. Sentential adverbs	78

Chapter 3

Tense and Aspect	83
3.1. The expression of Aspect	84
3.2. Perfective	85
3.3. The na Imperfective	86
3.4. The ta Imperfective	91
3.5. Imperfective vs. Imperfective	93
3.6. An overall view of the expression of Aspect	97
3.7. Past	99
3.7.1. The semantics of ba	99
3.7.2. The origin of ba	102
3.7.3. The syntactic identity and position of ba	104
3.8. Tense auxiliaries	108
3.8.1. Bin and the specific future	108
3.8.2. Ba and the non-specific future	113
3.8.3. A semantic analysis of the tense auxiliaries	115
3.9. Questions of scope	117

Chapter 4

The noun phrase	125
4.1. Introduction	125
4.2. Composition and derivation	125
4.2.1. Composition	126
4.2.2. Derivation	129
4.3. Inflectional morphology: the plural	131
4.4. The determiners	135
4.4.1. The article	135
4.4.2. The demonstratives	140

4.4.3. The possessives	141
4.4.4. Quantifiers and numerals	142
4.4.5. A conclusion on Kriyol specifiers	148
4.5. Noun phrases with adjective phrases	148
4.6. Coordinated noun phrases	149
4.7. Special types of NPs I: pronouns	150
4.7.1. Personal pronouns	150
4.7.2. The ‘neutral’ pronoun <i>i</i>	160
4.7.3. The reflexive - possessive pronouns	165
4.7.4. The reciprocal	168
4.7.5. Quantifying pronouns	169
4.8. Special types of NP II: nominal infinitives	175
4.9. Relative clauses	177

Chapter 5

The complex sentence	187
5.1. Introduction	187
5.2. Complement sentences	188
5.2.1. Complement sentences under factive verbs: pa	188
5.2.2. Complement sentences under declarative and epistemic verbs: kuma	190
5.2.2.1. Complement sentences of declarative and epistemic verbs: a follow-up (nos)	203
5.2.3. Adjunct complement sentences	204
5.3. Gerundive complements and comparative constructions	210
5.3.1. Gerundive complements	210
5.3.2. Comparative constructions	212

Chapter 6

Unbounded dependencies: topicalization, focalization, and questions	217
6.1. Topicalization	217
6.1.1. Topicalization without a resumptive pronominal	218
6.1.2. Left dislocation (LD)	219
6.1.3. Floating quantifiers and the null object issue	222
6.2. Focalization	227
6.3. Questions	230
6.4. Expletive subjects and raising verbs	237

Chapter 7

Middles, Passives, and Causatives	241
7.1. Middles and Passives	241
7.2. Causatives	246
7.2.1. Causative constructions	247
7.2.2. Causative verbs	251
7.2.2.1. The representation of CVs	252
7.2.2.2. The unaccusativity issue	256

Chapter 8

Beyond the sentence: a few considerations on Kriyol texts, especially comic-books	263
--	-----

Notes	269
Chapter 1	269
Chapter 2	270
Chapter 3	277
Chapter 4	280
Chapter 5	286
Chapter 6	289
Chapter 7	292
Chapter 8	294

References	297
------------------	-----

Index	307
-------------	-----

Acknowledgments

First of all, my gratitude goes to Professor Pierre Alexandre who introduced me to Kriyol more than fifteen years ago, and who directed the thesis that was the germ out of which this book grew, for better or for worse. Pierre Encrevé, who sat in the jury and seems never to have wavered since in his faith in my abilities (I wish I could say the same!) must be included in these thanks.

Next, of course, I want to thank the informants who gave me their time, especially Aristide Gomes. Without his subtle and accurate judgements most of this book could not have been written. The long conversations I had with Jean-Louis Rougé, about linguistics and much else, in his house in Bissau (remember the Bairro de Ajuda, Jean-Louis?) helped me more than he can imagine.

Pieter Muysken must be thanked not only for having considered this book worthy of publication, but also for all the improvements he suggested. Naturally, the usual disclaimer is in order: he is not to be held responsible, etc.

I am grateful to Claire Lefebvre first for her trust and friendship, then for having financed the composition of this book as part of the activities of the *Projet Créole* which she has been running for four years at the *Université du Québec à Montréal*. Robert Ciesielski and Monique Poulin were always competent and friendly in composing the text, and I thank them for all the care they put into it.

Abbreviations for sources

AK	Alain Kihm
B	<i>Bambaram</i>
BPB	Benjamim Pinto Bull
CS	Centros de Saude
DR	Doneux & Rougé
EG	Emilio Giusti
FJDM	Fernando Julio, <i>Tris N'kurbadus: Dokumentu maxnu</i>
FJGK	Fernando Julio, <i>Tris N'kurbadus: Garande konkursu, sangui nobu</i>
GM	Gomes & Mendonça
HGCS	Humberto Gonçalves, <i>Calerom di Sorti</i>
HGDB	Humberto Gonçalves, <i>Mingon Bicu: Bumbadur di Dabi</i>
HGGN	Humberto Gonçalves, <i>Graxadur n'pustur</i>
HGMT	Humberto Gonçalves, <i>Mon di Timba</i>
HGRB	Humberto Gonçalves, <i>Mingon Bicu contra rei di buli</i>
HGTD	Humberto Gonçalves, <i>Tempu di Duburia</i>
HGTM	Humberto Gonçalves, <i>Tchor Mama</i>
I	Informant
K	<i>Kansala</i>
MC	<i>Manual de conversação</i>
MJAP	Manuel Julio, <i>Ntori Palan: Adjudanti di nhu Parbai</i>
MJBA	Manuel Julio, <i>Ntori Palan: Bindidur di Alumino</i>
MJMB	Manuel Julio, <i>Ntori Palan 9: Muru di Bruntuma</i>
MJPB	Manuel Julio, <i>Punta pa sibi bom</i>
MK	<i>De Mandem a Kansala</i>
MM	Montenegro & Morais
MSDB	Malamba Sissé, <i>Djon Bulidur</i>
MSDM	Malamba Sissé, <i>Domba Massi na Italia</i>
MSLK	Malamba Sissé, <i>Tchicu Bolô 6: Lubu kema kosta</i>
MSMM	Malamba Sissé, <i>Tchicu Bolô n° 8: Mininu mufunadu</i>
MSNP	Malamba Sissé, <i>Tchico Bolo na Portugal</i>
RB	Radio Bissau
S	Scantamburlo
TM	Teresa Montenegro
V	<i>Vanželyu</i>
W	Wilson 1962

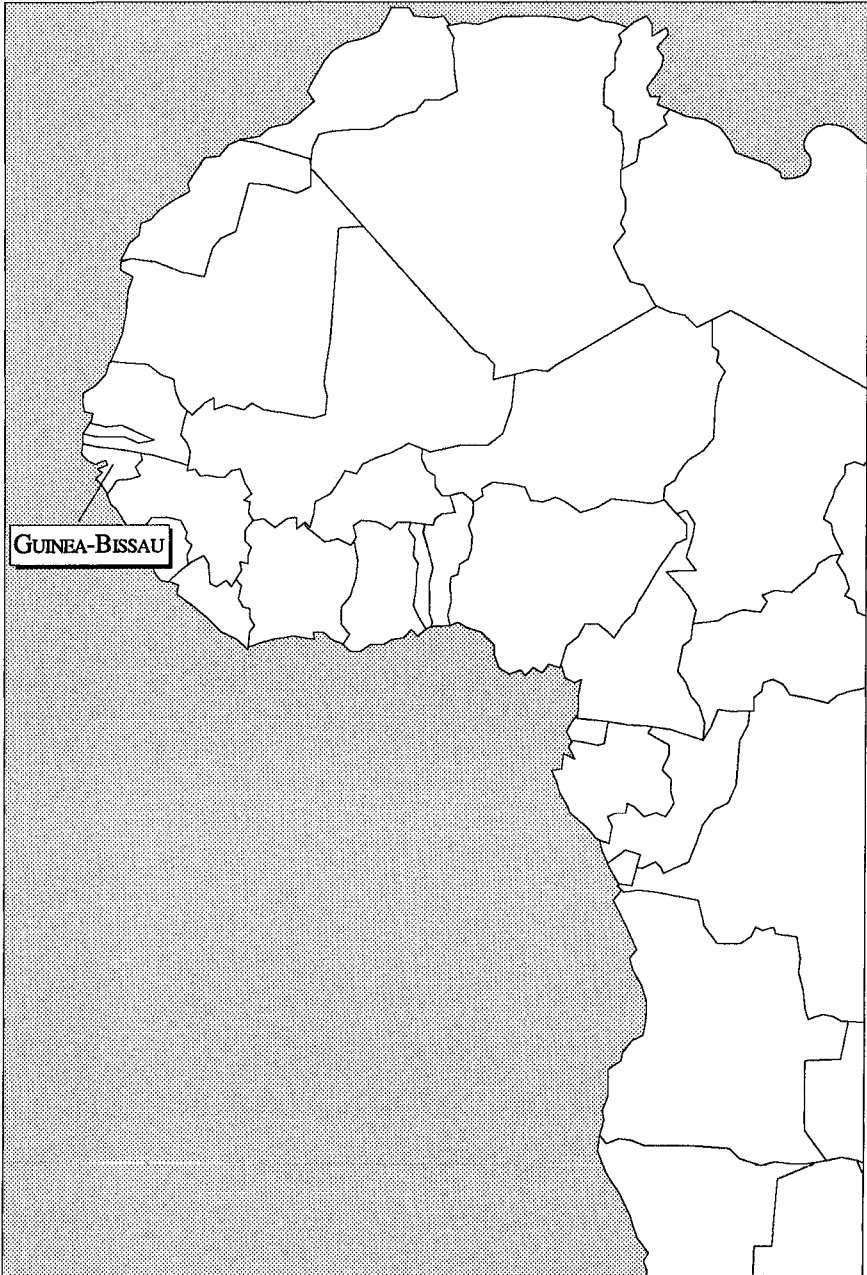

Chapter 1

Introduction

*O mar salgado, quanto do teu sal
São lágrimas de Portugal!*

...

*Valeu a pena? Tudo vale a pena
Se a alma não é pequena.*

*Quem quer passar além do Bojador
Tem que passar além da dor.*

*Deus ao mar o perigo e o abismo deu,
Mas nele é que espelhou o céu*

(Fernando Pessoa, *Mar português*)¹

1.1. History

Yes, it all began there, in Portugal, between Lisbon, Sagres, and Lagos, in the first half of the 15th century. From there the Portuguese (and a few Genoese in their pay) set sail southward with the dual aim of assaulting Islam from the rear and of finding new markets not in the hands of the Moors for gold and spice trade. Faith and profit went hand in hand, as they often do in human endeavours (for a careful assessment of the motives and vagaries behind the Discoveries, see Thomaz 1989). Little did the sailors know, when casting off, that the end of the route lay more than fifty years and ten thousand miles away.

Madeira, the Canary Islands and the Azores were easy to reach, all of them in the 1420s. The barrier, more psychological than real, lay south of Morocco. Beyond that, Ptolemaic geography and Aristotelian physics predicted a world of scorching heat and untold monsters. Despite their fears and numerous setbacks, the Portuguese pushed on. In 1434, Gil Eanes reached Cape Bojador, and in 1441 Antao Gonçalves was at Cape Blanco near the limit of present-day Rio de Oro and Mauritania. By then, the Europeans had realized that they were still on Earth, not on Mercury, and that the people they met, although darker and darker, did not carry

their mouths in the middle of their bellies. Senegal and the Cape Verde Islands were reached in 1445; Casamance and present-day Guinea-Bissau in 1446 first by Nuno Tristão (killed by a poisoned arrow in a skirmish with the local people), then by Alvaro Fernandes in a subsequent voyage the same year; Sierra Leone in 1462; Benin in 1471; Zaire in 1482; the Cape of Good Hope in 1487 (by Bartolomeu Dias). Vasco da Gama crowned the enterprise by attaining Mozambique and India in 1498.

Then others came: Spaniards, Englishmen, Frenchmen, Dutch. They continued what the Portuguese had initiated, almost always at the latter's expense. So many things ensued from this gigantic adventure that we cannot even think of reviewing them. Just look at the world we live in. *Criador do mundo moderno* 'creator of the modern world' was Pessoa's qualification for the legendary Prince Henry the Navigator (1394-1460) who supposedly set the whole thing into motion. As a poet Pessoa was right, although probably less so as a historian. Among the things that ensued, some were horrible: the world's first 'modern' genocide was committed in the wake of the Discoveries, in the holds of the slave-ships and in the New World plantations. Some were rather good: in spite of all preconceptions, minds broadened. Recent events have exposed that crass xenophobia, although everywhere virulent, is especially widespread in those European countries that remained encapsulated during the period when others were rubbing themselves against the wide, frightening world (on these first contacts, see Medeiros 1985, Horta 1991a,b; on the Europeans' fright before the 'Dark Continent', see Arendt 1979; the classical exposition remains Conrad's 'Heart of Darkness'). Finally, there were morally neutral, but scientifically interesting fall-outs, among them the spread of a few European languages over the whole planet and the consequent arising of a new species of languages, the so-called Creole languages.

The language to which this book is devoted belongs to this species. It wouldn't exist without the chain of events just sketched. It is spoken in Guinea-Bissau, former Portuguese Guinea, and in Casamance in the south of Senegal, and it has long been known as *crioulo* or Guinea Portuguese Creole (in Casamance **lingua kriston** 'Christian language' is also used as a designation). I will use the vernacular name, that is Kriyol (also pronounced /kiryol/ or /kiryol/).

Actually, the fact that Kriyol is a Creole language will play little role in the remainder of this book. I will take Kriyol for what it presently is, viz. an ordinary representative of the natural class 'human language', about which I will attempt to develop that particular kind of theory which is called a grammar. Nevertheless, the fact that, contrary to what is the case for a majority of languages, the inception of Kriyol can be more or less accurately pinpointed in history, and its genesis seems to be the result of a rather unique combination of socio-historical factors, this fact

cannot be fully ignored in a work purporting to present the reader with as faithful an image as possible of the linguistic object in question. Therefore, I will now retrace what is known or guessed about the history of the language, ending with a brief presentation of its present (beginning of the 1990s) situation.

1.2. A history of Kriyol: facts and suppositions

As usual, there are more of the latter than of the former. As already mentioned, the stretch of land that is now the coast of the Gambia, Casamance, and Guinea-Bissau was reached in 1446 by two successive Portuguese discoverers, the first of whom died in the enterprise (on the discovery of Portuguese Guinea, see Mota 1946). This means that the very first precursor of Kriyol — let us call it proto-Kriyol after Rougé (1986) — may have been in existence by the end of the 15th century. Unfortunately, we know very little about what occurred in that period in the territory just outlined.

Black slaves of both sexes were captured and brought back to Portugal as early as the mid-15th century. Several thousands of them were reported to live in Lisbon by the beginning of the 16th century. It was mainly domestic slavery, much milder it seems than what would later be developed in the New World. The slaves were rather free to move about and to mix with the surrounding white population — into which they ultimately merged without leaving any recognizable phenotypical trace (see Boxer 1963; Goodman 1987). Since Naro's (1978) article on the origins of pidginization, there has been much discussion on the issue of the variety of Portuguese black slaves in Portugal may have spoken. According to Naro, it was an artfully devised pidgin (his 'reconnaissance language') that the Portuguese deliberately taught the slaves in order to first be able to communicate with them, then use some of them as interpreters (*linguas*) in subsequent expeditions. This view has recently been challenged — rightly so in my opinion — in favour of the notion that what the slaves learnt was in fact a foreigner talk variety of Portuguese which they then used for communication between themselves (see Clements 1992 building on Goodman 1987). On the other hand, although some authors cast doubt on the reliability of contemporary theatre as a document for this 'Black Portuguese' (*língua de preto* — see Teyssier 1959), careful examination suggests that such literary texts can be used with a good measure of trust. In particular, the language 16th century playwrights (chief among them Gil Vicente) put in the mouths of the impersonated slaves shows striking, if limited, similarities with the present Portuguese Creoles of West Africa, through some phonological and a few morphosyntactic features that no native Portuguese speaker

could have invented (see Kihm 1992b). Given the back and forth traffic that existed between Portugal and West Africa,² it is conceivable, then, that this Portuguese Pidgin served as a basis for at least the proto-creoles of the Cape Verde Islands and Senegambia.³

Dispute has been rife as well — at least in the tiny world of interested scholars — around the issue of the immediate provenance of Kriyol. Traditional wisdom had it that creolization first took place on the Cape Verde Islands — indeed a prototypical setting for this process — whence the creole was then carried over to the continent. Agents of such transference would have been the *lançados* ('castaways') or *tangos-mãos* (?). This is how one called those Portuguese marginals, many of them with a criminal record or a Jewish parentage (which amounted to the same after 1495), who 'threw themselves' (*lançaram-se*) into the heart of darkness in order to trade with whoever they pleased — at a time when African trade was the monopoly of the Crown and commercing with anyone but its official agents was strictly forbidden. Before making the final thrust they normally spent some time in the Cape Verde Islands where they were in position to pick up the creole or creolizing pidgin. Contemporary descriptions depict them settled in villages of the interior, with women and children, acclimatized and socially integrated to the point of donning local clothes (or absence of them), practicing local religion, and accepting ritual scarifications. One thing, apparently, they did not give up, namely their language (or a variety thereof) which they transmitted around them and to their progeny (see Silva 1970).

However, the importance of the *lançados* in spreading Portuguese in the Senegambian area should not obscure the crucial role played by a different category, viz. the *grumetes*. 'Shipboys' — since this is what the term means — was the name given to Africans who had become Christians, worked for the Portuguese as intermediaries in the dealings with 'traditional' Africans,⁴ and settled in special villages or neighbourhoods near Portuguese outposts such as Cacheu (founded 1588) or Ziguinchor. *Grumetes* thus formed a special social group, neither fully African, nor fully Portuguese — in short, a creole group. There is every probability, then, that they were instrumental in shaping and, above all, preserving the creole in a continental environment which does not a priori appear propitious to the existence of such an object — if compared with the typical insular situation (on this, see Rougé 1986; Couto 1992).

Although chronology is of necessity uncertain, one may surmise that Kriyol was more or less fully formed by the beginning of the 17th century. The supposition is borne out by the presence in modern Kriyol of a few lexical items which were still in common use in 16th century Portuguese but not afterward, such as *misti* 'want' from *ter mester* 'need' (Modern Portuguese *precisar*), *montyadur*

'hunter' from *monteador* (MP *caçador*), or *limarya* 'animal' from *alimaria* (MP *animal*). Phonological features such as the palatal stop /c/ where Modern Portuguese has /ʃ/ written *ch* also point to a period when the affricated realization /tʃ/, now limited to Northern dialects, was more widespread and could still be heard in Lisbon (see Neto 1988:453ff. on the presence of numerous emigrants from the North — called *ratinhos* — in 16th century Lisbon).

For the next three centuries, i.e. until the 1920s, the sociolinguistic position of Kriyol remained unchanged, except insofar as the *grumete* group expanded and followed the Portuguese to new settlements such as Bissau (1686). Kriyol was their native and distinctive language. Perhaps a more or less pidginized variety continued alongside for use in dealing with the 'uncreolized' Africans, but there is no evidence for it — while there is evidence that the *grumetes* knew other languages besides Kriyol. The first Kriyol documents are from the 19th century, beginning with the sketchy overview of Bertrand-Bocandé (1849). Then we have a study by Schuchardt (1888) based on data provided by Barros (1882). The later, himself a Creole born in Bissau, did much to diffuse knowledge about the language and its oral literature at the turn of the century. As we see it in Schuchardt's and Barros's essays, Kriyol does not look different then from what we hear now. Only the delineation of geographical dialects (Cacheu, Geba, Bissau) was more clear-cut, especially if compared to the present-day situation where the Bissau dialect has to all intents and purposes absorbed its competitors, and the only distinct geographical variety is that of Ziguinchor, outside Guinea-Bissau (on Kriyol dialects, see Gomes & Mendonça 1981; Pinto-Bull 1989).

The 20th century was to bring portentous changes here as elsewhere. Until then, the Portuguese had been content — out of necessity rather than by choice — to stay in their towns, pay tribute to the local kings, and use their little colonized colony as a very secondary source of slaves (until the 1880s) and tropical goods (peanuts, palm oil, a little rubber after 1890). Now, in the wake of the big European scramble for Africa, they decided to seriously set to and take real control of a territory the lawful possession of which had been awarded them at the Berlin Conference (1884-1885). The Portuguese, with the assistance of the *grumetes*, launched a series of 'pacification' campaigns, meeting with fierce resistance, and culminating with captain Teixeira Pinto's bloody operations of 1913-1915.⁵ After that, the country was entirely conquered and 'pacified', even though the final submission of the Bijagos took a little more time, with a last revolt in 1936 (on this whole history see PAIGC 1974).⁶

The crucial effect of these events from the point of view of the history of Kriyol was that they seriously disrupted the traditional patterns of exchange in the country. Populations moved, and new contacts were established, be they violent or

peaceful. The trend was only reinforced by the more systematic colonial exploitation that followed the pacification, one of the means of which was forced labour. Perhaps for the first time since the early days of the discovery, the need of a *lingua franca* was urgently felt. None of the autochthonous languages could provide it because none had interethnic currency.⁷ Neither could Portuguese for the simple reason that there were never enough Portuguese in the territory to promote the use of their language. So it had to be Kriyol, by then a firmly established autonomous system not linked to its lexifier language by a continuum .

This was the first real expansion of Kriyol outside its original community. Yet, there is no evidence that this expansion was accompanied by a significant amount of (re)pidginization, although the social stratification of the language certainly complexified as a result. (What I mean by this is that the new, second-language Kriyol speakers finally learnt it well and fully, even if they retained local accents and mannerisms.⁸)

On the other hand, it is also during the post-1920 period that Kriyol was for the first time openly resisted and stigmatized. In 1940, primary education for the 'indigenes' was officially entrusted to the catholic missions. All teaching had to be in Portuguese; local languages and Kriyol were explicitly banned. Then, in 1946, a bill of law spelt out the criteria for distinguishing the indigenes (*indígenas*) from the Portuguese citizens (*cidadãos portugueses*) among the Africans. Besides economic conditions, the most important criterion was being able to speak, read and write the Portuguese language — and also being well-behaved (*ter um bom comportamento*), that is not to practice the 'customs of the common people of their race' (see Pinto-Bull 1989:108ff.). No wonder then that Kriyol, although certainly not declining, even growing in use, ceased to meet with the same kind of scholarly and literary recognition as it did to some extent before World War I.

The first modern description of Kriyol is due to Wilson (1959, 1962). Wilson stayed in Guinea-Bissau (then Portuguese Guinea) at the very end of the colonial period, just before the struggle for independence began. The variety he rapidly, but very competently described in his 1962 monograph is that spoken as a first language in Bissau — that is the same variety that will be studied in the present book.

During the War of Independence (1961-1974), Kriyol blossomed again. In the ranks of the PAIGC (*Partido africano da independência de Guiné e Cabo Verde*) it became both a practical tool for linguistic unification within the Party and the armed forces and a symbol of the new Bissau-Guinean nationality.⁹ Even the Portuguese had to recognize its utility as a propaganda medium.

In 1974, when Guinea-Bissau emerged as an independent country with international recognition and sympathy, the prospects of Kriyol looked brighter than

ever before. There were serious talks of making it, if not the official language of the young Republic (that was to remain Portuguese because of the felt need of maintaining narrow contacts with the other former Portuguese colonies of Africa and with *lusofonia* in general), at least a *primus inter pares* among the so-called 'national' languages. In particular, Kriyol was destined to become a basic tool in teaching literacy to a population the vast majority of which was still illiterate.

Although such official plans never came to much, it is true that Kriyol knew a remarkable expansion in the 1970s and the 1980s. In Bissau and the remaining cities (Bafata, Farim, Geba), it has become to all intents and purposes the sole language of everyday intercourse. It even made strong inroads into the Eastern regions where Fula and Manding had hitherto successfully blocked it from spreading. Cultural productions also increased: poetry, songs, a film (*Mortu Nega* 'The dead said no'), and, last but not least, comic books. The latter (about which see Kihm & Rougé 1988, Pinto-Bull 1989, and chapter 8 of the present book) will be used in the following pages as an important source of examples.

Asked if I was optimistic about the future of Kriyol a few years ago, I would have answered with an unequivocal yes. Its development and the fact that it was kept clearly distinct from Portuguese — the fact, in other terms, that there was no continuum of the sort one observes, e.g., in the Caribbean — made it an almost sure bet that it would evolve into a fully self-standing language whose existence was not under any foreseeable threat.

I am less confident now. Recent history has drastically changed the situation in the country. In 1990, Guinea-Bissau converted to parliamentary democracy and a free market. As a consequence, the Portuguese, whose presence had been minimal since the independence, started to come again, either to retrieve abandoned and subsequently nationalized ownerships, or to do fresh business from the newly opened Sheraton Hotel. Television also appeared and, while a good part of the radio programmes are in Kriyol, television is all Portuguese, with its inevitable contingent of Brazilian *telenovelas* (soap operas). True, it only broadcasts a few hours during the day and few Guineans are rich enough to afford a set. Nevertheless, there is no doubt that the cultural and linguistic influence of television will increase in the near future.

The consequence is not so much that Kriyol is directly threatened, but that, probably for the first time, a linguistic continuum with Portuguese is in the making. More or less decreolized varieties existed before, but they were by and large limited to the marginal social category of people with a high school or college education. Now there is every probability that the continuum will progressively encompass more and more speakers in different social strata. Of course, nobody can tell what the end result will be. Yet, what is observed in similar cases where

a creole language stands in a continuum situation with its lexifier makes the prospects for the ultimate survival of Kriyol rather bleak, even though it certainly has several decades ahead of it. Better that the people should survive than their language, one might say looking at the tragedy that is now Africa. However that may be, the linguist is here definitely out of his depth, which is why I do not pursue the matter any further, as this is not a political essay.

1.3. The study of Kriyol: what, how, and why?

As mentioned above, only one variety of Kriyol will be taken into account here. Put differently, this is not a sociolinguistic study. Except in passing, geographical or social variation will not be considered; neither will such phenomena as decreolization or diglossia. The task I set to myself is to analyse the syntax of that variety of Kriyol which I will henceforth call ‘central’. This, let me say it in passing, explains why the informants are not individually identified in the text, but are merely indicated with an I (for informant - see list of abbreviations for sources). Such details as age and sex are indeed irrelevant to the ‘hard’ grammatical issues studied in this book, and mentioning them would be nothing but unneeded pseudo-accuracy

Except for the persistence of a distinct dialect in Ziguinchor (see Chataignier 1963), geographical variation is almost extinct in any event. There must be significant differences, in contrast, between Kriyol spoken as a native or primary language in the cities, principally Bissau, and Kriyol spoken as an L2 by country people or recent city-dwellers, and that would be worth investigating. I won’t do it, however, and I will focus on the first kind of Kriyol.

Another differentiation one frequently hears about is that between **kriyol fundu** ‘deep Kriyol’ and **kriyol lebi** ‘light Kriyol’. As the names show, those are folk categories, reminiscent of similar lay classifications in other creole settings. By and large, **kriyol fundu** refers to the basilect, while **kriyol lebi** corresponds to an array of mesolectal systems with a varying amount of Portuguese interferences.¹⁰ **Kriyol fundu** should not be confounded in principle — although the distinction is often blurred in practice — with **kriyol antigu** ‘old Kriyol’, i.e. the ‘purer’ language (in the sense of showing no Portuguese influences) supposedly spoken by the ancients (meaning generally the grandparents’ generation). Whether the distinction is real or essentially mythical is something I will not attempt to decide. I will consider both **kriyol fundu** and **kriyol lebi** as variants of central Kriyol — that is Kriyol as it is spoken by young to middle-aged city dwellers, a description that fits my informants as well as the comic-book authors on whom I drew heavily. In the

speech of these people, 'deep' and 'light' features may be found more or less in free variation. I will acknowledge the 'light' features as they come, but I will keep a definite bias towards the 'deep' ones, because they are, I think, the most interesting from an analytic point of view. Also they still constitute the bulk of the syntax of my oral and literary informants.¹¹

The preceding considerations answer the question of what to study. I will now say something of the 'how'. Language description is not an end in itself. It has the status experiments have in the physical sciences: a means of testing theories against facts which are themselves theory-laden. We touch here on a well-known epistemological argument into which I will not enter further. Suffice it to say that, in accordance with this view, the present book will attempt to be as much a faithful exposition of Kriyol syntactic facts as an exploration into a number of syntactic problems that those facts may help resolve. And since neither facts nor problems exist independently of specific hypotheses about the world, it is necessary for me to elucidate the theoretical stance I will be taking before starting the whole thing.

Basically, this work is cast into the framework of Generalized Phrase Structure Grammar as developed in Gazdar et al. (1985). Actually, descriptive concerns were prominent in my decision to choose this framework. Indeed, a first attempt using Government and Binding (in the version of Chomsky 1981, 1986) as a theoretical tool had left me deeply dissatisfied. It seemed to me I was spending more time resolving theory-internal issues than dealing with problems posed by the object of study. Granted, the boundary between both kinds of questions is and must be fuzzy given the logic of scientific investigation, so I'm quite ready to admit that my qualms ultimately stemmed from an inability of mine to apply GB in a creative way. Another researcher with a different turn of mind would probably not have known them. After all, GB and GPSG (and other theories), with all their divergences, are competing versions of what may be called rational linguistics, and the application this work aims to be cannot be enough to decide between them — supposing any empirical evidence to ever be enough (even though it is sometimes possible to suggest that a given treatment is more adequate than another). Here is a domain where the temperament of the student is almost as important as the merits of the theory.¹²

Be it as it may, the fact remains that that sort of difficulties disappeared the moment I turned to GPSG. The format of the theory, particularly its use of fully explicit rules, makes it especially easy to state the kind of things that have to be stated when one tries to light up one's way through a language's syntax. At the same time, during the three years it took me to write this book, I became increasingly convinced that linguistic explanation must be looked for in the semantic or cognitive dimension if the term is to have a meaning at all — which

does not imply that all linguistic ‘facts’ can be explained in this way, only that if no semantic explanation can be found, then they must be considered accidents (like, say, the fact that the preterite of *teach* is *taught*, but that of *reach* is *reached*). In this respect, GPSG is certainly a theory that makes all the necessary room for semantics. Yet, it is dubious that Montague’s intensional logic as it is geared to the syntactic apparatus of GPSG is an adequate tool to the analysis of meaning in natural languages, except in domains where the meaning is already sufficiently abstract to be translatable into logicese without too much loss (see, e.g., my analysis of Kriyol aspect in chapter 3). This is why I had frequent recourse to this offspring of GPSG, Head-driven Phrase Structure Grammar (HPSG), whose situation semantics is closer, it seems to me, to an adequate theory of natural semantics (see Pollard and Sag 1987; Borsley 1991).

In the following pages I will also make frequent use of the parallel representation style of presentation and explanation presented e.g. in Sadock 1991. As will be seen, or so I hope, it often permits elegant and thoroughgoing analyses, especially in those areas of grammar where different components interact in a complex way.

Perhaps the preceding comments will strike some readers as outrageously eclectic. Why, will they grumble, doesn’t the chap stick with one theory rather than presenting us with such a hotchpotch? Supposing for a minute these angry readers not to be wishfully invented strawmen — after all they imply there will be readers — I have this to answer: first, there is a deep commonality between the theories I use, including some ventures of my own devising, namely, as already suggested, their basic semantic or cognitivist orientation.

Secondly, I simply do not believe in theoretical (or ideological) commitment. As Jorge-Luis Borges wrote somewhere, a theory is never more than the submission of all aspects of reality to one of them. This is why theories must be transient and partial. Methodological anarchism, the principle that ‘anything goes’ (Feyerabend 1988) is therefore a reasonable option. In our field, ‘Anything goes’ means ‘Use the theory or model that is best suited to your problem’. For example, Autolexical Syntax is especially well equipped to deal with causative constructions and intermodular mismatches in general — what other models call movement or unbounded dependencies (see chapter 7). On the other hand, phrase structure and argument relations are lucidly exposed in models like GPSG or HPSG. That said, the decision to consider this or that model ‘best suited’ is ultimately warranted by no criterion outside the linguist’s and his/her colleagues’ feeling on the matter. There is no ‘scientific method’ as Chomsky repeatedly emphasized (see, e.g., Chomsky 1980, 1985). Put differently, the scientific method is nothing more (nor less) than educated curiosity and debate.

Finally, why study Kriyol at all? 'Why' is an uncomfortably ambiguous little word. It means either 'because of what' or 'to what purpose', with a huge twilight zone where causes and desires intermingle under the deceitful heading of 'reasons'. Now, it is almost an act of faith that linguists and scientists in general ought not to be exposed to such a question, however it is interpreted. KNOWLEDGE is deemed to be a sufficient reason before which all must bow their heads. Actually, as everybody knows, this is a laugh and a sham.

For one, the causes that drive one to be a linguist rather than a baker (to cite an equally honourable profession) and to specialize in this or that subject matter are multiple and mainly unconscious. Advancing science is certainly not one of them, unless it is as a late rationalization.

As for the question about the purposes of the study, in contrast, it is possible to say more. The question is especially pressing when the object under study happens to be situated in the Third World. This being so, I feel there would be some indecency in entertaining the delusion that the present work can be of any immediate utility to the speakers of the language and to their country. That Kriyol may benefit in the long run of having been made once again into the subject of a scientific investigation (provided of course the said investigation has merits besides being couched in the planetary lingua franca), I can only hope, although I am not very confident.

No, if there are gains to be expected from the present study, they will have to be field-internal. While it is certainly not a determining cause for scholarly activity, the advancement of science is no less certainly an essential effect of it. Three kinds of gains can be expected.

On the one hand, there is the very fact of analysing a language in the framework of explicit theories. There is always a chance that our understanding of human language will deepen a little bit. Then, there is the fact that Kriyol is a creole language. As I said, this character will largely be ignored in the following pages. Nevertheless, it is certainly not meaningless that rarely before had a member of this group (or pseudo-group) been submitted to so extensive an investigation.¹³ Creole studies, as a subdiscipline, may then benefit. A few comparisons with other creole languages will be attempted anyway, for example in the domain of tense-aspect marking and semantics.

Finally, Kriyol is a particular creole language inasmuch as, contrary to its Caribbean congeners for example, it remained in contact with its substratum, and it probably formed over a relatively protracted period of time. It is a 'fort creole', not a 'plantation creole' to use Bickerton's classification. Although issues of creolization theory — relexification vs. LBH, for instance — will not be really tackled in this book, a detailed knowledge of Kriyol such as I tried to provide will

certainly prove useful in the debate now raging on those issues. Moreover, I took opportunity of the easy identifiability of Kriyol's substratum (and/or adstratum) to propose contrastive analyses of the relevant 'local' languages whenever I thought it useful — and found it feasible. In so doing, I tried never to forget the possibility that apparently 'exotic' features one is tempted to ascribe to African interference may well be rooted in the lexifier language itself, in one of its ancient or modern, dialectal or standard varieties. Relexification seems to me to be the most plausible account now available of creole genesis (see e.g. Lefebvre 1986). To insist on having it explain everything, however, would be the surest way to sign its doom. Here again, eclecticism — also known as respect for complexity — is a virtue, not a sin.

1.4. A phonological sketch of Kriyol

The phonology of Kriyol is well, if cursorily, described in Wilson (1962). Mboj (1979) is also a good account. Here, I will content myself with an informal presentation aiming principally to allow the readers to attain a correct pronunciation of the examples.

I use the official spelling established, but never legally enforced, a few years ago (1981 — see text of *Projecto de Ortografia e Separação das Palavras em Crioulo* in Rougé 1988:153ff.). Since this spelling is phonological and follows the IAI rules for the transcription of African languages rather faithfully, there is no need for a special section on how to pronounce the different letters. Let me just mention that I depart from the official solutions on a few points: instead of *ñ* I use *ny*, mainly for convenience, and secondarily to secure some consistency with *ly*, which has to be used for the palatalized liquid occurring in words recently borrowed from Portuguese and written *lh* in that language.¹⁴ I do not capitalize **n** meaning 'I'; I do not use a hyphen to connect **n** 'me', **u** 'you', and **l** 'him/her/it' with the verb that governs them, neither do I write them and the verb as if they were one word.¹⁵ As a final word on the subject, it is worth repeating that the official orthography is only a proposal, and I never saw it used outside the few existing official publications in Kriyol. Comic-books authors, in particular, use home-made spellings with varying degrees of consistency. The examples taken from these authors have therefore been transliterated. (But I sometimes mentioned the original spelling when I thought it revealing of the writer's insight into his language.)

1.4.1. Syllabic structure

Kriyol is mainly a CV language. The coda of the final syllable in a word is a special position as it must be either empty (the word then ending in a vowel) or occupied by a sonorant (/N/, /r/, /l/, /y/, /w/, with /N/ an unmarked nasal segment realized in this position as a velar nasal /ŋ/ and/or as a nasalization of the preceding vowel) or /s/. Word-internally one meets with more variety (e.g. /kum-sa/ ‘begin’, /kap-li/ ‘run away’, /suk-ta/ ‘listen’, etc.), but such forms are relatively rare, and they may be considered surface realizations through deletion and resyllabification of forms with only open syllables: /ku-mu-sa/, /ka-pi-li/, /su-ku-ta/ — forms which are also commonly heard. On the other hand, one might consider that /kumusa/, etc. are in fact the secondary forms obtained through epenthesis. I will not try to solve this issue. Let me only mention that optional epenthesis yielding a CV structure is indeed a common phenomenon; for instance, **problema** ‘problem’ may be realized [prublema], [purblema] or [purublema]. In practice, I tried to be reasonably consistent. For words like **problema**, the easy solution which I adopted is to use as a citation form the variant that is closest to the Portuguese etymon, here *problema*.¹⁶ **Kumsa** (P. *começar*) is clearly more frequent than /kumusa/, so I retained it. The contrary is the case, however, with **sukuta** as compared with /sukta/ (P. *escutar*). Each word is a special case, in sum. Of course, my makeshift solutions ought to be corrected by a careful sociolinguistic inquiry.

As **problema** shows, primary consonant clusters (as opposed to secondary clusters due to vowel deletion as in /sukta/) are not entirely excluded in Kriyol. It is only that they must include a liquid and/or the fricative /s/ — and, of course, appear in syllable onsets. We thus find as permissible clusters (all of them possibly broken by epenthesis): /(s)p(r~l)/, /(s)t(r)/, /(s)k(r~l)/, /br~l/, /dr/, /gr~l/ /fr~l/. Notice this is the same list one finds in Portuguese.

Another implication of the CV patterns is that Kriyol words should normally begin in a consonant (that is to say, the syllable onset should not be empty). Actually, there are numerous exceptions to that principle, but it was certainly active as a historical trend. Witness such forms as **yagu** ‘water’ from P. *água*, **yermon** ‘sibling’ from P. *irmão* ‘brother’ (now also **irmon**), etc., where the pattern was realized through prosthesis of a glide, or the already mentioned **sukuta** from *escutar*, where it was attained through apheresis of the initial vowel and epenthesis.

Finally, a whole class of words, the so-called ‘phonaesthetic’ words, are exceptional vis-à-vis the CV pattern, as many of them show a CVC structure with an obstruent coda (e.g. **burmeju wak** ‘very red’ — see Chapter 2).

1.4.2. *Stress*

Kriyol seems to be a stress, rather than a tone or pitch-accent language. Instrumental studies show stress to be realized through a varying combination of intensity, pitch, and duration, where intensity is regularly the domineering factor (see Kihm & Laks 1989).

Stress placement depends on (a) the syntactic category of the lexeme; (b) syllabic structure. As for (a), the relevant distinction is between verbs and all other categories. Verbs, all of which end in a vowel except a small group of monosyllabic items (see Chapter 2), are stressed on the final syllable. Thus, **i kume** 's/he ate' is realized [iku'me]. Distorsions arise when the verb is preceded by an aspect auxiliary or the negation, for which see Kihm & Laks (1989) or the subject pronoun **n** 'I' (see Andrade, Gomes, & Teixeira 1992). In non-verbs, on the other hand, stress placement is determined according to the structure of the final syllable. If it is open, stress falls on the penultimate syllable (e.g. ['kasa] 'house', [ba'juda] 'young girl', etc.); if it is checked, it receives stress (e.g. [ka'cur] 'dog', [no'gos] 'business, trade', etc.). Note however that plural /-s/ (see chapter 4) does not influence stress placement (e.g. [ba'judas] 'young girls').

The preceding rules are only fully valid for integrated Kriyol lexemes of Portuguese or non Portuguese origin. Non integrated items of African origin (e.g. **jinpini** ['jimpini] 'spy') may behave otherwise. Moreover, stress placement and realization, especially in those items, is something that will vary a lot according to the ethnic and/or social origin of the speaker. On all this, I have no satisfying data. Note also that exceptions are also found among items of Portuguese origin generally belonging to a somewhat learned register (e.g. ['lapis] 'pencil', [gra'matika] 'grammar', etc.). Stress, or rather absence of it, does not modify the realization of the vowels as it does in Modern European Portuguese, except that final unstressed /a/ is regularly raised to something like [ʌ].

1.4.3. *Vowels*

Kriyol may be described as a five vowel system /i, u, e, o, a/, all of which can be nasalized (see next section). The mid vowels /e/ and /o/ are realized moderately open, with a variation the conditions of which have not been explored. Similarly, relatively open (perhaps [-ATR]) variants of /i/ and /u/ can be heard, again with no clear conditionning.¹⁷ The raising of final unstressed /a/ has already been mentioned. Other final unstressed vowels are variably devoiced, depending mainly on the character of the preceding consonant (e.g. **patu** 'duck' can be realized ['pat^h] where exponent [h] indicates a devoiced vowel of indistinct timbre). In the relative

pronoun **ku** (see chapter 5), the vowel can be reduced to a kind of schwa, or even deleted. This process seems to be specific to this lexical item.

It is not clear that there are diphthongs in Kriyol. In fact, there are reasons to believe that in words like **kay** ‘to fall’ or **kaw** ‘place’, the final glide is a coda (hence a consonantal segment) rather than a component of the nucleus (see Kihm 1986). Word-internal hiatus is always resolved through glide insertion, so that **dia** ‘day’, for instance, is realized [‘diya], and **bua** ‘to fly’ is realized [bu‘wa].¹⁸ Transmorphic hiatus, on the other hand, as in **n oja u** ‘I saw you’ is resolved either through glide formation yielding [ŋo‘jaw]¹⁹ or through assimilation yielding [ŋo‘jo:], apparently in free variation. Similarly /pa i/ ‘that s/he’ will be pronounced [pay] or [pe:], /pa e/ ‘that they’ [pe:], and so forth. Notice that such cases are the only ones where distinctly long vowels can be observed in Kriyol — discounting the fact that vowels are often longer when stressed.²⁰

1.4.4. Consonants

The following consonant chart can be established for Kriyol:

m	n	ny	g
b	d	j	ŋ
p	t	c	k
(v)	z	ž	
f	s	(š)	
w	r	y	
		l	(ly)

The parenthesized segments occur only in words of Portuguese origin which entered the language recently through borrowing (e.g. **privatizason**), or creolized words that are somehow realigned on their Portuguese etymon. These segments are thus reliable indicators of the degree of decreolization of a given speech or register. For example, ‘beer’ used to be **serbeja** (still given in Wilson 1962). Nowadays one almost only hears **serveža**, a form much closer to Portuguese *cerveja*. Similarly **disa** ‘to leave’ is increasingly realized **diša** after Portuguese *deixar*. Numerous other examples could be adduced. Abstracting away from these segments makes it appear that, in basilectal phonology (now largely an ideal object), the voicing contrast is limited to stops. This makes Kriyol identical to the surrounding Atlantic and Mande languages whose consonant inventories likewise ignore voiced fricatives.

Other segments invite few comments, except to mention that /c/ and /j/ are palatal stops,²¹ that /r/ is flapped rather than trilled, and that /l/ is always coronal, never velar as it can be in Portuguese. Nasals, however, are a bit more problematic. For one, the phonemic status of /ŋ/ is not clear. Word-finally or before a velar

consonant it is a realization of the archisegment /N/ (see below). There are a few words, all of African origin, where it is found word-initially (e.g. **ɲoroto** ‘scythe’, from Mandinka). Yet, there are also Portuguese derived words where, as a result of apheresis, one finds an initial sequence /ŋg/ (e.g. **ngoda** ‘to seduce’ < P. *engodar*) which does not always seem phonetically distinguishable from the putative /ŋ/ just mentioned. It is therefore an open question whether a velar nasal phoneme should be posited, which would be limited to a designated portion of the lexicon and to a specific position within the word.²²

This takes us directly to the question of nasalization and prenasalized segments. As it was treated at length in Kihm (1986), I will be brief. As mentioned above, all vowels can be nasalized. Nasalization takes place in the context /VNC~#/ , i.e. a vowel followed by the underspecified segment (or archisegment) /N/ (thus excluding /m/) and a consonant or a word boundary. While nasalizing the preceding vowel, /N/ assimilates to the following consonant, being thus realized as a homorganic nasal (e.g. **manduku** ‘club’ [mãnduku] vs. **mangu** ‘mango’ [mãŋgu] vs. **injison** ‘injection’ [ĩŋjisõ]). Word-finally, /N/ is realized as a velar or not at all (**con** ‘land’ [cõŋ] or [cõ]). The question now is whether the nasal and the obstruent belong to different syllables (e.g., [mãn-du-ku]) or to the same syllable ([mã-nduku]). The latter analysis amounts to assuming prenasalized complex segments in the phonology of Kriyol (see Feinstein 1979; Ewen 1982). Examples such as the already mentioned **ngoda**, or **ntindi** ‘understand’ and many more, would tempt one into making precisely that assumption. Yet, instrumental analyses have shown the /N/ in such forms to be distinctly syllabic, with a clear vocalic prothesis coloured according to context (hence [ũŋ(g)oda], [ĩntĩndi]). The final solution is thus not settled. It is even possible that the phonemic status of the /NC/ sequences will vary according to factors such as the speaker’s ethnic origin.

1.5. Phonological developments from 16th century Portuguese to Kriyol

I found it useful to say a few words about the phonological changes that occurred between 16th century Portuguese (including its putative pidginized variety: see Hart 1955; Teyssier 1980; Neto 1988) and Kriyol. Since we have few reliable data on old Portuguese suprasegmentals — and not many more on the same in Kriyol — I will limit myself to rapidly listing the changes in the domains of syllabic structure, vowels, and consonants.

As for the first of these domains, there is no doubt that the trend toward a consistent CV pattern was the main drive that directed the changes. Besides, the road to travel was not so long, since 16th century Portuguese was fairly much CV

itself, as compared with the present-day European variety. Unstressed vowels, be they final or word-internal, were distinctly pronounced, as they still are in Brazilian Portuguese. Hence CV was attained mainly through such processes as apheresis of initial vowels (very regular), and epenthesis, of which examples have already been adduced. To give just one more example, where both processes are represented, consider **sukuru** 'dark' from P. *escuro*. Glide prothesis has also been mentioned (e.g. **yabri** 'open' < P. *abrir*).

In the realm of oral vowels, it appears that Kriyol preserved the Portuguese vocalism fairly accurately, except that height contrasts in mid-vowels (/e/ and /o/) disappeared. In 16th century Portuguese, the only vocalic reductions concerned final unstressed /e/ and /o/, realized [i] and [u]. Kriyol inherited this feature (e.g., **siti** 'oil' < P. *azeite*, **netu** 'grand-child' < P. *neto*). When oral vowels mutated, it was generally due to some process of vowel harmony, as in **sibi** deriving both from *saber* 'know' and from *subir* 'go up'. As this example shows, closed /e/ changed to /i/ when part of an infinitive ending (not in the Ziguinchor dialect), and also in other cases which I shall not review.²³

Nasal vowels were more affected by creolization. In particular, Kriyol totally ignores the nasal diphthongs that were only beginning to arise in the 16th century as a result of the unification towards /ão/ of the Galego-Portuguese complex system (see Neto 1988:487ff.). Through whatever process, Kriyol inherited only /õ/ (e.g. **mon** 'hand' < 16thcP *mão*, **pon** 'bread' < 16thcP *pão*, **lyon** 'lion' < 16thcP *leão*).

As already suggested, diphthongs disappeared entirely. Either they were reinterpreted as sequences of a vowel and a non-syllabic glide, as in **bay** 'go' from P. *vai* 's/he goes'; or they were simplified as in **siti** from *azeite* (see above). Other examples are **liti** 'milk' from *leite*, **kusa** 'thing' from *coisa* or *cousa*, **puku** 'few' from *pouco* (pronounced [poUku] in the 16th century), etc.

In general, the segmental aspect of the Portuguese words was not subjected to dramatic changes. This is especially striking when one compares Kriyol with, for instance, the creole of São Tomé (see Ferraz 1979), where deletion of whole syllables and other disruptive phenomena were much more common (compare, e.g., Kriyol **dibinya** with São Tomense *dīvya*, both from *adivinhar* 'guess').

In the domain of consonants, the loss of the voicing contrast in fricatives was already mentioned. On the one hand, the voiced counterpart /v/ of /f/ was replaced by /b/ (e.g. **baka** 'cow' from *vaca*). We may see here a change internal to the creolization process, considering that all the languages in the substratum lack /v/; we may also take into account the fact that the /v/-/b/ merger is a well-known feature of Portuguese northern dialects, which was certainly present in Lisbon at the relevant period (see above). In fact, both causalities probably converged. The absence of /v/ in the substratum suffices to explain why it could not survive into

Kriyol; what it does not explain, however, is why /v/ changed to /b/ rather than to something else, for instance /w/ as in Wolof *welo* 'bike' from French *vélo*.

Until about 1550, on the other hand, standard Portuguese included four sibilant consonants, two fricatives (/s/ written *s* or *ss* and /z/ written *s*) and two affricates (/ts/ written *c* or *ç* and /dz/ written *z*).²⁴ This system was rapidly evolving toward the present system with only two fricatives: /s/ written *s*, *ss*, *c*, or *ç*, and /z/ written *s* or *z*.²⁵ In all probability, it is on this latter system that basilectal Kriyol is based, having merely eliminated the remaining contrast of /s/ and /z/ (again nowhere to be found in the substratum) in favour of the unvoiced member of the pair, so that we find, e.g., **kasa** 'house' from *casa* and **asin** 'so' from *assim*, **segu** 'blind' from *cego* and **siti** 'oil' from *azeite*.

Another source of Kriyol /s/ is the evolution of Portuguese /ʃ/ (*x*) and /ʒ/ (*j.g*). The former changed unexceptionally to /s/ as in **basa** 'lower' from *baixar*, **disa** 'leave' from *deixar*, **kesa** 'complaint' from *queixa*, and so forth. The latter changed either to /s/ as well (e.g. **susu** 'dirty' from *sujo*, **misa** 'piss' from *mijar*, etc.), or to the voiced palatal stop /j/ (e.g. **janta** 'lunch' from *jantar*, **lunju** 'far' from *longe*, etc.). This variation may represent the fact that Portuguese /ʒ/ has its origin in an affricate segment /dʒ/, the voiced counterpart of /tʃ/ (see below). According to historical grammars, the change /dʒ/ > /ʒ/ was accomplished before 1450, but there is uncertainty on this issue (see Teyssier 1980:34-35). The dual Kriyol treatment might indicate that the affricate pronunciation was still alive to some extent at the end of the 15th or even the beginning of the 16th centuries.

The unvoiced affricate /tʃ/ (*ch*), in contrast, always changed to the unvoiced palatal stop /c/ (e.g., **cabi** 'key' from *chave*, **fica** 'shut' from *fechar*, etc.).²⁶ This is in accordance with the well-established fact that only during the 16th century did /tʃ/ (*ch*) begin to evolve toward the present-day fricative pronunciation /ʃ/, indistinguishable from the 'old' /ʃ/ written *x*. (The affricate is still well entrenched in Northern Portugal.)

The voiced palatal stop /j/ also corresponds to Portuguese /l/ (*lh*) as in **paja** 'grass' from *palha*, **kujer** 'spoon' from *colher*, etc.

Finally, notice that the palatal realization of syllable-final ('implosive') fricatives that is so characteristic of modern European Portuguese, never made its way into Kriyol, except quite recently. Thus **bisti** 'to dress' is pronounced [bis'ti] (compare P. *vestir* [və'stir]), **du** 'two' is pronounced [dus] (compare *dois* [dɔis]), and so forth. This is not surprising since there is no trace of the process in Portuguese before the middle of the 18th century (see Teyssier 1980:68ff.).

The other consonants invite no historical comment. Let me just mention a /r/ > /d/ change, as in **bida** 'become' from *virar* or **sedu** 'be' from *ser*. The phonemic equivalence of /r/ and /d/ is well-attested in the Atlantic languages, particularly in

Manjaku. Moreover, it is a shibboleth of Black speech in 16th century Portuguese theatre (see above). It is therefore remarkable that it should be limited to a few lexical items.

1.6. Relation with Cape-Verdean Creole

As mentioned above, the possibility that Kriyol would be an offshoot of Cape-Verdean has often been entertained. Although I do not share this opinion in such an extreme form, there is no doubt that Kriyol and Cape-Verdean constitute a language group vis-à-vis the other Portuguese-based creoles of Africa, i.e. São Tomense, Angolar, Principense, and Annobonese. Proximity is especially obvious with the Sotavento dialects of Cape-Verdean, to the point that a fair degree of intercomprehension can be achieved. However, the grammatical differences between Kriyol and Cape-Verdean as a whole, particularly in the Tense-Aspect and determiner systems, are far-reaching enough that no assimilation appears to be feasible. Kriyol, with its varieties, and Cape-Verdean, with its varieties, do constitute a sub-group within Portuguese-based creoles — let us call it Senegambian Portuguese Creole, for instance — but they are distinct languages by all usual criteria.

Chapter 2

The simple sentence

2.1. Introduction

This chapter deals with a number of basic syntactic issues such as the composition of the predicate, the relation of the verb to its complements, and the relation of the predicate to its subject. Resolving these issues will allow us to determine the structure of the simple sentence in Kriyol. By simple sentence I mean a declarative sentence (S) corresponding to a complete, autonomous utterance that denotes some state of affairs, and where all expected arguments are present. Embedded sentences and questions are thus excluded from this chapter, as are all kinds of non finite sentences and partial utterances. Passive and causative constructions will also not be considered until a later chapter.

Having been delineated in this way, a Kriyol simple sentence comprises an obligatorily present subject and a predicate, in this order. The predicate consists of a verb followed by its arguments, a VP, that may be immediately preceded by an element traditionally called an ‘aspect marker’, which I will analyse as a kind of auxiliary verb. (No ‘aspect marker’ implies that the aspectual value of the predicate is Perfective.) Non subcategorized items such as adverbials must stand outside the subject-predicate complex. The following sentence illustrates (A is for Aspect; as already indicated, I means that the sentence was given me by an informant; AK indicates a sentence of my own devising; other abbreviations — for which see list of abbreviations for sources — refer to comic-book titles or to authors from whom I drew examples):

- (1) Jon ta pista si amigus dinyeru senpri ku disgostu. (I)
John A lend his friends money always with sorrow
John always lends money to his friends with sorrow.’

Note that, apart from its present position, *senpri* ‘always’ could be inserted to the immediate right of *Jon* or of *pista*, but nowhere else. The following immediate dominance (ID) rules partially generate (1):

- (2) a. S → XP, H [-SUBJ], (ADV), (PP)

Rule (2a) is but the well-known subject-predicate rule $S \rightarrow NP, VP$, making allowance for the fact that (i) the subject is not necessarily an NP, although it certainly is XP's most ordinary value; (ii) S and VP are instances of the same category distinguished by the value of the feature [SUBJ] — Ss have a subject, VPs don't — so that V (the head of VP) is indeed the head (H) of S. S can optionally contain adverbials and PPs.

- (2) b. $VP[+AUX, Ai] \rightarrow H[i], VP(\mathbf{na}, \mathbf{ta})$
 c. $VP \rightarrow H[3], NP, NP$ (e.g. **pista** 'lend')

Rule (2b) introduces the auxiliary or aspectual verbs **na** and **ta** which impart a specific aspect value to the predicate they head. [A] is a non-Boolean feature the values of which will be analysed in Chapter 3. In (1), **pista** 'lend' is a ditransitive verb, hence the lexical ID rule (2c).

Subjects always precede predicates in Kriyol, which can be expressed through the following Linear Precedence (LP) statement:

- (3) $XP < [-SUBJ]$

Given this and (4):

- (4) $[SUBCAT] < \neg [SUBCAT]$

which states that subcategorizing lexical items precede their non-subcategorizing phrasal sisters, rigid SVO order ensues, as well as Spec-N1 and N-AP order within NP (e.g. **un omi garandi** 'an old man'), or P-NP order within PP. LP statement (4) is also responsible for the fact that auxiliary verbs precede the verb they modify. Non subcategorized elements such as the PP in (2) are not ordered relative to other elements. They cannot, however, intrude into an ordering specified by an LP statement, which means, for instance, that no non subcategorized or adjunct PP may intervene between the subject and the predicate, or the auxiliary and the main verb, and so forth.¹ In fact, this leaves only the final position for PPs, unless they are topicalized. Adverbial placement is somewhat freer, depending as it does on scope properties, as will be shown below.

Given this, the present chapter will proceed as follows. First, I will examine what the predicate may consist of. Adjective and noun predicates, in particular, will be considered. Then we will study negative predicates. Finally we will deal with the arguments of the verb, i.e. with subjects, objects, and adjuncts. Tense and aspect 'markers', on the other hand, will be the subject of the next chapter.

2.2. The composition of the predicate

From a logical point of view, the predicate of a proposition having a truth value (e.g., *It's raining*) must be marked for Tense and/or Aspect since T/A obviously contributes to the truth value of this particular collocation of a given predicate with a given subject. In Kriyol, however, as already suggested, T/A is never a feature of the main verb, as it is entirely expressed by auxiliaries (Aspect) or an adverbial (Tense — see Chapter 3). There are reasons, nevertheless, to assume that a feature [VFORM] having [\pm FINITE] as its values is apposite for Kriyol verbs regardless of morphological invariability, so that it makes sense to use the term 'predicate' to refer to the VP sister of V[+AUX] (see (2b)).

Given this, X' theory, in its most simple-minded interpretation (but see Kornai and Pullum 1990), would have us expect the predicate (i.e. VP) to be uniquely headed by a [+V] item. We shall see that Kriyol indeed fulfils this expectation, however not in an obvious way given the existence of so-called 'noun predicates' in the language. Before coming to those, I will begin by first examining 'ordinary' predicates headed by verbs, and then, to the extent that they can be separated, adjectival predicates.

2.2.1. Verbal predicates

The bulk of this section will consist of as thorough an examination as possible of the characters of verbs in Kriyol. This implies a review of verb morphology and composition,² of argument structures, and of the different kinds of verbs (especially modal and so-called 'aspectual' verbs).

2.2.1.1. Verb morphology

Contrary to what obtains in the lexifier language Portuguese, Kriyol underived verbs have no inner structure. Compare, e.g., P. *chamar* 'call' whose morphological structure may be represented as [_V[_X cham]][_V ar] (see Williams 1981), to its Kriyol cognate *coma* that can only be represented as [_V coma]. In other words, there is no distinction of stems and affixes in simple Kriyol verbs.³ It is a fact that a majority of Kriyol verbs end with one of the two vowels /a/ and /i/. But this is because Kriyol verbs of Portuguese origin derive either from so-called 'first group' verbs in /-ar/ or from second or third group verbs in /-er/ or /-ir/ which, in the Bissau dialect, merged to /i/ (see Introduction). In no case could these vowels be analysed as affixes or thematic vowels as in Portuguese. Note further that one also finds verbs ending with /e/, of Portuguese (e.g. *kume* 'eat') or African (e.g., *nyeme* 'crunch') origin; verbs ending with /u/, all of them of

African origin (e.g., **banbu** ‘carry on one’s back’, **jungutu** ‘squat’) except two: **sedu** ‘be’ (P. *ser*) and **kunpu** ‘build’ (P. *compôr*); and at least one verb ending with /o/, viz. **koko** ‘defecate’. All vowels, in sum, may show up as final vowels in Kriyol verbs, a situation strikingly different from what is found in Portuguese.

It is also for historical reasons that Kriyol verbs never end with a closed syllable, since they probably derive from the Portuguese infinitive via deletion of final /t/ and/or from the indicative present third person singular. The only exceptions are a small group of verbs that end with /y/ or /N/: **bay** ‘go, leave’, **cay** ‘commit adultery’, **foy** ‘libel’, **kay** ‘fall’, **ley** ‘read’, **puy** ‘put’, **roy** ‘gnaw’, **say** ‘go out, come from’, **bin** ‘come’, and **den** ‘hurt’. All these items are derived from the indicative present third person singular of Portuguese irregular verbs (*vai, cai, lê, poe, rói, sai, vem*), to the exception of **cay** and **foy**, both of African origin, and of **den** which probably results from the conflation of P. *doer* with an Atlantic root such as Manjaku *de*.

Of course, a corollary of the absence of inner structure in Kriyol underived verbs is the total lack of overt tense, aspect, mood, etc. inflection.

2.2.1.2. Verb composition

Composition (see fn. 2) takes two forms in Kriyol. One is the use of the inversive or pejorative prefix /dis-/. True, some of the verbs beginning with /dis-/ can hardly be said to be composed, as there are no lexical items identical to them but for the absence of the prefix. Examples are **diskisi** ‘forget’ (***kisi**) or **dismanca** ‘destroy, abort’ (***manca**). Notice, however, that the first syllable can still be identified as the prefix on clear semantic grounds.⁴ Among the remainder, two categories should be distinguished. First there are verbs which have a direct equivalent in the lexifier language, such as **diskarga** ‘discharge’ from P. *descarregar* ‘id.’ (and see **karga** and *carregar*). It is evidently through such items that the prefix penetrated into Kriyol. Once there, however, it became autonomous, so that a second group of verbs with /dis-/ have no Portuguese reflexes, being pure Kriyol formations, such as, e.g., **disburgunyanta** ‘give back face’ (**burgunyanta** ‘to shame, make lose face’ — and notice P. *desvergonhado* ‘shameless’ which demonstrates the lack of connexion between the Kriyol and the Portuguese derivation in this case), or **disdingi** ‘cease to live alone’, from **dingi** ‘live alone’ possibly of Balanta origin (see Pinto Bull 1989)

The second composition process is reduplication, as in the following examples:

- (5) Lubu fika na yurni-yurni minjer kusas na kintal. (I)
 hyena stay A steal-steal woman things in barnyard
 ‘Hyena kept lifting things from the woman’s barnyard.’

- (6) I junta-junta si fijos. (I)
 s/he join-join his/her children
 'He gathered his children.'
- (7) I pega na yanda-yanda tudu ladu. (I)
 s/he hold A walk-walk all side
 'He began walking to and fro.'
- (8) Ora ku bu oja algin sinta i na bati planu, ka bu ba
 time that you see somebody sit he A beat plan NEG you go
 ta coma-coma l. (FJGK)
 A call-call him
 'When you see somebody sitting and planning in his mind, don't
 start calling him all the time.'

It is apparent that the primary meaning of Kriyol verb reduplication is iterativity in time or in space.⁵ For example, (6) implies that the children were scattered over an area, and that he (Hyena) had to go at it several times before he succeeded in gathering them. Similarly in (8), reduplication alone suggests repeated calling. That reduplication is a lexical process is demonstrated by the fact that reduplicated verbs behave in every respect like simple words whose 'opaque' character they share. Nothing may intervene between the two occurrences, and derivative affixes such as passive /-du/ attach to the right end of the compound (e.g., **bu coma-comadu** 'you were called all the time', not ***bu comadu-coma** or ***bu comadu-comadu** — see Chapter 7).

Reduplication applies freely to all verbs whose meaning is compatible with iteration. With adjectives, on the other hand, the semantic correlate is intensification rather than iterativity, as in **kinti-kinti** 'quick, fast' (lit. 'hot-hot') or **pikininu-pikininu** 'very small'. It is conceivable, though, that iterativity and intensification are two sides of one and the same concept, the former for extensive processes that may be thought of as discontinuous in space and/or time, the latter for intensive states that are considered to be continuously spread over space and/or time. I propose to call this common concept 'incrementation', as it is obviously (as well as iconically) related to the cognitive ability of adding one more item to a series, or one more degree to a scale.

2.2.1.3. Subcategorization types

All the possibilities normally encountered in natural languages are of course present in Kriyol. A few types pose specific problems, however, and deserve some analysis beyond being merely mentioned.

There are first those verbs like **pista** 'lend', **da** 'give', **sina** 'teach', etc., which take two complements in a way that is reminiscent of the English double object construction. More will be said about them in connexion with the semantics of

complement types and the passive. The distinction between so-called unergative one-place predicates whose subject is semantically an Agent (e.g. **durmi** 'sleep', **jopoti** 'walk noiselessly', **ri** 'laugh', and so forth) and unaccusative one-place predicates whose syntactic subject may be analysed as a Theme (e.g. **bin** 'come', **ciga** 'arrive', **kay** 'fall', and so forth — see Perlmutter 1983; Burzio 1986) will also prove relevant when we study the causative constructions. And semantically complex verbs such as **sobra** 'remain' or **falta** 'lack' will receive especial attention in due time.

Another set of verbs subcategorizes for clausal arguments. The natural place to deal with it will be Chapter 5 where the embedding processes of Kriyol are examined. Two types of verbs should be introduced now, however, because of their significance for the kinds of predicates that can be built in the language. (Note that Kriyol has no 'raising' verbs since, as we shall see, **parsi** 'seem' and related verbs are constructed only with an expletive subject and a finite clause.)

The first type are the so-called 'modal' verbs **pudi** 'can/may', **misti** 'want', **dibi di** 'must', **ten di** 'have to', **ciga di** 'already be/do', **kaba di** 'finally be/do', **tenta di** 'try', **pega** 'start, set about Ving', **nega** 'refuse', **seta** 'accept', **osa** 'dare', **tarda** 'be/do a long time':

- (9) Nya irmon misti bay utru tera. (AK)
 my brother want go other country
 'My brother wants to go to another country.'
- (10) N ka na pudi pera l. (AK)
 I NEG A can wait-s/he/it
 'I won't be able to wait for him/her/it.'
- (11) N dibi/ten di bay gosi. (AK)
 I must/have of go now
 'I have to go now.'
- (12) Omi garandi ciga di konta nu kil storya. (AK)
 man big arrive of tell us that story
 'The old man already told us that story.'
- (13) E kaba di sedu rey. (I)
 they finish of be king
 'They finally became kings.'
- (14) Lebri ba toma si vyola i pega toka. (I)
 rabbit go take his violin he start strike
 'Rabbit went to take his violin (and) he started to play.'
- (15) Alunu nega tarbaja. (AK)
 pupil refuse work
 'The pupil refused to work.'
- (16) Ze ka ta osa kurinti karu. (AK)
 Ze NEG A dare run+CAUS car
 'Ze doesn't dare to drive a car.'

- (17) N *tarda* *misti skola.* (I)
 I be-a-long-time want school
 'I was a long time wanting to go to school.'

All these verbs have as a common characteristic that they select non finite VPs whose logical subjects are denotationally identical to their own subjects. That is to say, they are Control predicates, i.e. functions from VPs to VPs (see Gazdar et al. 1985). ID rule (18) may therefore be proposed:

- (18) VP[+MODAL] → H[n], VP[-FIN, AGR NP] (***misti, pudi, dibi di, tarda***, etc.)

The feature [AGR NP] indicates that the daughter VP agrees with the subject of the mother. Only *misti* 'want' seems to be different in that it may also subcategorize for a different-subject proposition, which must then be finite and introduced by an overt complementizer (see Chapter 5). Notice that a few modal verbs do not govern the sister VP directly, but via *di* 'of'. I will return to this point. Let me mention for the present that the semantic contribution of *di* appears to be essential, since all the verbs that require it have different, non modal meanings without it: *dibi* 'owe', *ten(e)* 'have, possess', *ciga* 'arrive', *kaba* 'end, be finished'.

In fact, this observation may be extended to all modal verbs, in that they all have non modal uses where they either subcategorize for NPs (19) or PPs (23) or are intransitive (20):

- (19) N *misti es libru.* (AK)
 I want this book
 'I want this book.'
- (20) N *ka pudi mas.* (AK)
 I NEG can more
 'I can't go on/ I'm exhausted.'⁶
- (21) *Kil baka ka ta osa fugu.* (I)
 that cow NEG A dare fire
 'That cow is afraid of the fire.'
- (22) *Nya pape ka seta n skola.* (I)
 my father NEG accept me school
 'My father didn't accept my going to school.'
- (23) N *tarda na Bisaw.* (AK)
 I be-a-long-time in Bissau
 'I was/lived in Bissau a long time.'⁷

In view of the semantic stability across constructions (e.g. *tarda* 'be a long time [in doing something or in a place]'), a redundancy rule linking the various uses seems to be the right way of capturing the fact that such verbs may figure both in (18) and in ID rules like (24) or (25):

- (24) VP → H[n], NP (***seta***, etc.)
 (25) VP → H[n], PP (***tarda***)

On the other hand, it seems clear that *skola* in (22) cannot be taken extensionally as a term referring to an object-of-the-world, but must be understood as an intensional generic designator (the school as an institution). With ‘ordinary’ verbs like *bay* ‘go’ as in *n bay skola* ‘I went to (the) school’, in contrast, there is a potential ambiguity between both interpretations, which cannot be resolved by the presence of a determiner as in English. Similar remarks could be made about the interpretation of *fugu* in (21) or of the understood object of *pudi* in (20) — necessarily some process requiring physical or mental exertion. The propositional or syncategorematic character of the complement, whether it is a VP, an NP, a PP,⁸ or a null string, seems therefore to be a constant for this class of verbs. I shall try and formalize these observations later on.

Modal verbs must be distinguished from another category represented by such items as *jumna* ‘be/do first’, *kiri* ‘be/do a little’, *torna* ‘be/do again’, *yar(a)* ‘be/do almost’:

- (26) *Jila ta jumna i toma dinyeru.* (I)
 shopkeeper A do-first he take money
 ‘The shopkeeper first takes the money.’
- (27) *Rapas kiri medi kacuris.* (I)
 boy do-a-little be-afraid-of dogs⁹
 ‘The boy is a little afraid of dogs.’
- (28) *I na finta elis te na dia ku e ka torna pudi sufri.*
 s/he A trick them until on day that they NEG do-again can suffer
 ‘She’ll trick them till they can’t take it any more.’ (EG)
- (29) *Karu yara maja l.* (MSNP)
 car do-almost hit him
 ‘The car almost hit him.’

None of the verbs in (26-29) could be used absolutely or with a nominal argument. Obviously, indeed, *kiri* meaning ‘love’ (see fn. 9) must count as a separate lexical entry. And the same is true of intransitive *yara* meaning ‘be wrong’ (see fn. 9) and of transitive *yara* meaning ‘be at fault with somebody, let down’.¹⁰ (See below for *jumna*.) Note further that, although *i fetiseru* is a perfect sentence meaning ‘He is a sorcerer’ (see below for noun predicates), ‘He is a bit of a sorcerer’, on the other hand, could never be translated as **i kiri fetiseru*, which shows that these verbs strictly select VPs or extensions of VPs. Neither can they passivize, while this is at least a theoretical possibility for the items in (9-17, 19-23). More obviously, clefted constructions involving the VP complements of (26-29) are quite impossible, in contrast with the VP complements of (9-17). Thus, (30’) is grammatical as the focalized equivalent of (30), but (31), in contrast, is pure gibberish:

- (30) N misti fasi kila. (AK)
 I want do that
 'I want to do that.'
- (30') Fasi kila ku n misti. (AK)
 do that that I want
 ?'It's doing that that I want.'
- (31) N yara fasi kila. (AK)
 I do-almost do that
 'I almost did that.'
- (31') *fasi kila ku n yara (AK)
 do that that I do-almost

What this evidence shows is that these verbs actually behave like the aspectual auxiliaries introduced in (2b).¹¹

Syntactic considerations thus seem to clearly separate modal verbs from auxiliaries in Kriyol. Semantically, the former correspond to autonomous concepts (CAN, DARE, LAST, and the like), whereas the latter correspond to modifications of concepts, i.e. special ways in which the processes referred to are achieved (ALMOST, FIRST, and the like, and aspectual specifications). For instance, if (15) is interpreted as *nega'* (*tarbaja'* (*alunu**))(*alunu**), we may surmise that (27) should be represented as (*kiri'*(*medi-kacuris'*(*rapas**)))(*rapas**). That is, *nega'* 'refuse' is a relation between an individual, the pupil, and a property, that of working, whereas *kiri medi'* 'be a little afraid' is a property in itself. This is not to deny that the distinction may be fuzzy at times. Nevertheless, the correspondence between the semantic and the syntactic rules seems to hold good for a rather clear-cut core of items.

Both sets, on the other hand, are Control predicates. As before, I will use the feature [MODAL] in order to distinguish between them. The unmarked value of the feature is <->, and so it will not appear unless marked.

An interesting exception to this statement is *jumna* which, as shown in (26), does not select a VP, but rather a complementizerless sentence, S[-COMP], whose subject cannot be anything but a pronoun coreferential with the subject of *jumna*. We therefore need a special ID rule such as (32):

- (32) VP[+MODAL] → H[n], S[AGR NP] (*jumna*)

Furthermore, *jumna* is another instance of those verbs which are also used as 'full' verbs, in which case it means 'overtake', as in:

- (33) Jon jumna Ze. (I)
 John overtake Joe
 'John overtook Joe.'

where it is presupposed that John and Joe have been competing with one another in some way. Interestingly, the same presupposition is also present in a sentence like (26) which implies that, say, the shopkeeper was anxious about not getting his money and grabbed it as soon as it was produced. This suggests something like ‘anticipate’ as an overall meaning for **jumna**, both as an ordinary verb as in (33) — whose ‘real’ meaning would be that John anticipated or was before Joe from the viewpoint of somebody standing at the finishing line, i.e. the opposite standpoint with respect to English — and as a modifying verb as in (26) or in the following, somewhat clearer examples:

- (34) N ka na jumna n beju. (HGCS)
 I NEG A anticipate I old
 ‘I won’t be old before my time comes.’
- (35) Kil rapas jumna i beju artis di nobu. (I)
 that boy anticipate he old before of young
 ‘That boy was old before ever being young.’

There might therefore be a more immediate link between **jumna**’s different meanings and uses than there is between the respective meanings and uses of **kiri** and **yara**. In spite of this distinction, though, **jumna** in (26) and (34-35) appears to be quite as dependent syntactically from the main verb as **kiri**, **yara**, etc. are. For example, the sentence **n beju** ‘I’m old’ in (34) cannot be topicalized to yield ***n beju, es ku n ka na jumna** /I old this that I NEG A anticipate/ ‘Old, that I won’t be before my time comes’. This justifies, I think, that we keep **jumna** in the same class with **kiri**, etc., so that (26) will be interpreted as (**jumna**’(toma-dinyeru’(i*)))(jila*).¹² I will return to the syntactic problem of verbs which select a sentence without a complementizer.

There is also the case of **kumsa** meaning ‘begin’ as an autonomous verb (**n kumsa nya tarbaju** ‘I began my work’). With a VP complement, **kumsa** is ambiguous between a modal interpretation ‘begin to’ as in **po kumsa da fruta** /tree begin give fruit/ ‘The tree began to give fruit’, and an auxiliary one ‘have just’ as in **pursor kumsa say** ‘The professor has just gone out’. Only the first reading is possible when the VP complement happens to be aspectually marked as in **mininu kumsa ta cora** /child begin A cry/ ‘The child began to cry’. I will return to this problem in connexion with the scope properties of the auxiliaries.

‘Auxiliary’ concepts such as those denoted by **jumna**, **yara**, etc. seem rather close, indeed, to what is traditionally labelled aspect, in one of the notoriously numerous uses of the term.¹³ Calling the verbs in (26-29) aspectual would be awkward, though, considering the service the notion of aspect has still to give in the present work. With regard to their meaning and in view of the fact that verbs like **yara** invariably correspond to adverbs in English or Portuguese,¹⁴ I propose

to call them Ad-verbs, with the hyphen as a graphic means of distinguishing them from the semantically cognate adverbs that do not have the morphosyntactical features of verbs, and the capital A as another visual reminder of the notion 'Aspect'. In terms of feature notation, on the other hand, the fact that Ad-verbs are not aspectual *stricto sensu* should suffice to distinguish them from the aspect auxiliaries **na** and **ta**. Neither is the feature [MODAL] necessary to set them apart from other Control predicates, since the latter do not bear the feature [AUX] which unites Ad-verbs and aspect verbs. Hence the following rules with (36) a revision of (2b):

(36) VP[-SUBJ,+FIN,+AUX, A_i] → H[n], VP[±AUX] (**na**, **ta**)

(37) VP[-SUBJ,+FIN,+AUX] → H[m], VP (**kiri**, **yara**, etc.)

(32') VP[-SUBJ,+FIN,+AUX] → H[m], S[AGR NP] (**jumna**)

The specification [±AUX] of rule (36) is destined to account for examples like (26) or (34) where the Ad-verb (i.e. [+AUX]) is modified by an aspect verb. In rule (37), the right-hand side VP is [-AUX] (the unmarked value of the feature). Rule (32') is simply a reformulation of (32). Of course, rules (36-32') have to be supplemented with a rule that takes care of the cases where no auxiliary at all is present:

(38) VP[-SUBJ, +FIN] → H[n], W

In (38), H is unmarked for aspect. In order to account for the fact that it nevertheless receives an aspectual interpretation, as will be explicated below, we need the following Feature Cooccurrence Restriction (FCR):

(39) FCR: [+SUBJ] ⇒ [+FIN]

According to (39), there are no non finite sentences (S or VP[+SUBJ]) in Kriyol; only VP[-SUBJ] may be non finite.¹⁵ Hence, given the Head Feature Convention (HFC), a VP heading an S will necessarily be finite. We can now posit (40):

(40) FCR: [+FIN] ⇒ [A_k]

This means that every finite predicate must receive an aspect value, thus ensuring that 'bare' verbs as in (38) get one. In (36-37), on the other hand, the right-hand side VP, be it [+AUX] or [-AUX], may be considered a non finite complement of the aspectual head, so that the aspect value is entirely supplied by the aspect auxiliary (see Chapter 3 on all these notions).

The syntactic difference between aspect auxiliaries and Ad-verbs may thus be expressed by assuming that the former bear an A feature in their lexical entries, while the latter do not, although they also include an AUX feature. These remarks will be further elaborated and modified later on, when the semantics of these

elements has been somewhat elucidated. Meanwhile, the existence of Ad-verbs as opposed to adverbs appears as an important distinctive feature when comparing Kriyol with its lexifier language. Note, in contrast, that Ad-verbs are found in all substrate languages, particularly Atlantic languages.¹⁶

Before (provisionally) concluding this matter, I would like to mention that at least one Ad-verb might be in the process of becoming an ordinary adverb, namely **yar**, a frequent variant of **yara**. Note first that **yar** deviates from the canonical form of Kriyol verbs (see above). In spite of this, it still is clearly an Ad-verb in the following example:

- (41) N kuda n yar tene un garafu na želeyra. (FJDM)
 I think I do-almost have a bottle in ice-box
 'It seemed to me as though I had a bottle in the ice-box.'¹⁷

It is clearly not one, in contrast, in (42) where it stands in the commanding initial position of sentential adverbs:

- (42) Yar i bindi si karu. (I)
 YAR s/he sell his/her car
 'He almost sold his car.'

Compare (42) with the 'decreolized' version **kwasi bindi si karu** lit. 'Almost he sold his car'.¹⁸ In (42), **yara** could not be substituted for **yar**, which suggests that only the latter can (but need not) be used as a 'deep' alternative form of sentence-initial **kwasi**, probably because of its 'unverbal' outlook.

To sum up on Kriyol lexical ID rules for VPs, and considering only the items already introduced, we arrive at the following, partial list of lexical ID rules:

- (43) VP[-SUBJ,+FIN,+AUX, ASPI] → H[x], VP[±AUX] (**na**, **ta**)
 (44) VP[-SUBJ,+FIN,+AUX] → H[y], VP (**yara**, etc.)
 (45) VP[-SUBJ,+FIN,+AUX] → H[y], S[AGR NP] (**jumna**)
 (46) VP[-SUBJ, +FIN] → H[n],W
 (47) VP → H[1] (**durmi** 'sleep')
 (48) VP → H[2], NP (**kume** 'eat')
 (49) VP → H[3], NP, NP (**pista** 'lend')

Note that I do not use integers to mark the subcategorization features of aspectual auxiliaries and Ad-verbs, but rather the letters [x] and [y] since their complements are VPs headed by any verbs including themselves.

Indeed, sequences of aspect verbs and/or Ad-verbs are frequent occurrences. We already saw that an Ad-verb can be modified by an aspect verb. Sequences of aspect verbs will be dealt with later on. Here is the right place, however, to say something about sequences of Ad-verbs. Two principles seem to regulate them: (a) the cardinality of the sequence is limited to 2 (at least I never observed any longer sequence); (b) up to semantic plausibility, all combinations are permissible. I give a few examples below:

- (50) Mininu torna yara kay. (I)
 child do-again do-almost fall
 'The child almost fell again.'
- (51) Dipus di kil riunyon n kiri torna kalma. (I)
 after of that meeting I do-a-little do-again calm
 'After that meeting I calmed down again somewhat.'

The semantic effect of conjoining **jumna** with **yara** should be noted:

- (52) Kontra i yentra kwartu i jumna i yara kay. (I)
 when he enter room he anticipate he pretend fall
 'As he entered the room, he was the first to pretend he was falling.'

Probably because of the overall meaning of **jumna**, which presupposes an intentionality, another meaning of **yara** emerges in (52), viz. 'pretend'. Since this meaning has certainly a lot to do both with the 'almost' and the 'to err' meanings — although I won't attempt to examine how precisely they might be related — I will consider this **yara** to be another instance of the Ad-verbial **yara**, not a separate entry like **yara** 'offend'.

In turn, rules (43-49) will licence tree (54) as a structural description of example (53):

- (53) Bu na jumna bu da kil omi un tapon na kabesa. (AK)
 you A do-first you give that man a knock on head
 'You will begin by giving the man a knock on the head.'

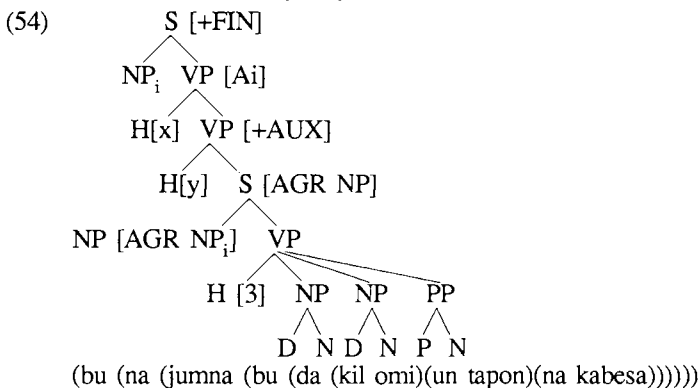

The following table summarizes the classification of Kriyol verbs elaborated so far (*u* stands for 'undefined', and see next chapter for the aspectual undefinition of ordinary verbs).

(55)	AUX	A	CONTROL
Ordinary verbs (durmi)	-	u	-
Control verbs (misti)	-	u	+
Ad-verbs (yara)	+	u	+
Aspect verbs (na/ta)	+	+	+

2.2.2. Adjective predicates

Adjectives are defined here following Chomsky 1970 (also see Gazdar et al. 1985) as [+N +V], i.e. ‘mixed’ items partaking of both nominal and verbal features, in accordance with their attributive (‘the white horse’) or predicative (‘the horse is white’) functions. The category looks at first blush as if it was absent in Kriyol, being replaced (as it is supposed to be in many languages) by fully verbal items variously called ‘stative’ or ‘quality’ verbs (see, e.g., Bickerton 1975). The following examples seem to support this assumption:

- (56) N ta kontenti ba na kil tenpu. (AK)
 I A happy PAST in that time
 ‘I was happy in that time.’
- (57) Es mininu na garandi. (AK)
 this child A big
 ‘This child is growing up.’
- (58) Nya pirkitu karu. (I)
 my parrot expensive
 ‘My parrot is expensive.’
- (59) Sapatus altus ki bonitu. (I)
 shoes high+PL that pretty
 ‘It’s high heels that are pretty.’

No copula is present in any of these sentences. Moreover, the same aspect and tense markers that are found with *bona fide* verbs are used in exactly the same way (cf. *ta* and *ba* in (56), *na* in (57)). Even the absence of an aspectual auxiliary in (58) and (59) has to be standardly interpreted as indicating perfective aspect (see Chapter 3), given the well-known semantic equivalence Perfective = Present with verbs referring to states.

A good case seems therefore to be made out for considering that Kriyol indeed lacks adjectives of the sort that is found in Portuguese or English and has stative or quality verbs [+V -N] instead, so that, e.g., *kontenti* in (56) ought to be glossed not as ‘happy’, but as ‘be-happy’. This would rather radically separate Kriyol from its lexifier language, making it similar, on the other hand, to its substrate languages which all seem to include items that may be analysed as quality verbs.¹⁹

Before we come to a firm conclusion on this matter, however, several observations have to be made. First, not all items corresponding to English or Portuguese adjectives unambiguously behave like verbs. Actually, only those items do that refer to basic qualities such as ‘big’, ‘small’, ‘happy’, ‘sad’, colours, and so forth. Take, on the other hand, the following example:

- (60) Kil tera (sedu) demokrátiku. (I)
 that country (be) democratic
 'That country is democratic.'

It shows that, with less basic, stylistically more or less 'learned' quality items, a copula **sedu** may be employed, which is excluded with items of the **kontenti** class (e.g. ***nya pirkitu sedu karu**).²⁰

Another difference between the two classes is that items like **demokrátiku** never occur with aspectual auxiliaries. For example, ***indústria na produktivu** cannot be formed on the model of (57) to mean 'Industry is becoming productive'. A verb such as **bida** 'become' or the copula **sedu** must be used (e.g. **indústria na sedu kada byas ma produktivu** /industry A be every time more productive/ 'Industry is becoming more productive all the time'). In the Past, two collocations are possible:

- (61) Kil tera (y)era (ba) demokrátiku. (I)
 that country be+PAST (PAST) democratic
 'That country used to be democratic.'
- (62) Kil tera i demokrátiku ba. (I)
 That country it democratic PAST
 'That country (it) used to be democratic.'

I will return below to the Past allomorph of the copula. The interesting fact for the present is that (61) is the central variant, whereas the construction exemplified in (62), although common, is regularly assessed as 'deep' (**fundu**).²¹ On the contrary, we saw it is the only possible construction with basic quality items.

It seems, thus, that we should at least distinguish between two different sorts of quality items in Kriyol: one corresponding to basic qualities and lexically realized as verbs; the other referring to more complex qualifications and spelt out as items that globally behave like adjectives. (Actually, the relevant distinction is probably historical rather than semantic, the verb-like sort being made up of creole items, while the adjective-like sort seems entirely composed of more or less recently borrowed items that did not enter the language through creolization, but directly from the superstrate.) Constructions such as (60) without **sedu** would then call for an explanation in terms of a null or zero copula, in line with what is usually proposed for languages like Russian or Modern Hebrew.

This classification is, however, unsatisfactory. Consider indeed that, not taking intonation into account, sequences like (58) above are structurally ambiguous:

- (63) S[+FIN]
 NP (nya pirkitu)
 VP[+ASP]
 H[x] (∅)
 VP[n](karu)
- (64) NP
 SPEC[+POSS] (nya)
 N1
 N (pirkitu)
 AP(karu)

(63) represents (58), i.e. the finite sentence meaning ‘My parrot is expensive’. In (64), on the other hand, we see the complex tree corresponding to the superficially identical (but for intonation) noun phrase ‘My expensive parrot’. The point is that (64) is indeed a licit analysis, clearly different from the one that would correspond to the relative construction **nya pirkitu ku karu** ‘My parrot that (is) expensive’. Such a difference is unexpected if Kriyol adjectives are indeed [-N +V] items, and it makes **karu** look very much like an attributive adjective. Conversely, no VP may be generated within a local tree whose root is NP, so that, e.g., **po kay** can only be a sentence meaning ‘The/a tree fell’, never an NP meaning ‘The fact that the/a tree fell’ with a structure like, perhaps, (65):

- (65) *NP
 N1 (po)
 VP (kay)

This may not be a universal filter. Indeed, Hale and Platero (1986:32) argue that, in Navajo, ‘The boy was not working’ and ‘(The fact that) the boy was not working’ have identical structures, which they theorize by assuming that the sequence belongs to a mixed category [+S +N]. Lefebvre and Massam (1988) also attribute nominal features to Haitian sentences by arguing that sentences, like NPs, may be headed by Det(erminer) (on mixed categories, also see Lefebvre and Muysken 1988).

Kriyol, however, is not that kind of language, and **nya pirkitu karu** can never mean ‘The fact that my parrot is expensive’. Now, this is a problem if we assume that **karu** is a verb. It would imply that, in structures like (64), a verb may be inserted within an NP, actually producing a structure like (65), with VP under NP rather than AP. Then, since VPs are functions from NPs to Ss, we would expect the meaning of (64) to really be ‘The fact that my parrot is expansive’ (‘the fact that’ = NP, ‘my parrot...’ = S) rather than the meaning it really and exclusively has. Note also that, in the negative, **nya pirkitu ka karu** is not ambiguous, as it cannot be an NP meaning ‘My unexpensive parrot’, but only the sentence ‘My parrot is not expensive’. This is significant because, as we shall see, **ka** ‘not’ must itself be considered a verbal element.

Another difficulty for the verb solution are the agreement facts as exemplified in (59). There, indeed, we see that **altus** 'high' agrees in number with the noun **sapatus** 'shoes', /-s/ being the plural marker.²² This is enough to show that it cannot be a verb, since verbs never exhibit any morphological agreement in Kriyol. It is true, on the other hand, that the predicate **bonitu** '(be) pretty' does not agree with its subject, and such an agreement would indeed be ungrammatical.

We are thus apparently forced to the conclusion that the same element is now a verb when it heads a predicate, now an adjective when it modifies a noun. A rather unsavoury result which I shall try to improve somewhat.²³

2.2.3. Noun predicates

Here is another difficult issue. It is a characteristic feature of Kriyol that copulative, identificational or predicational sentences may be realized without an overt copula. Let me first define a few terms. Copulative sentences are sentences whose semantic function is either to identify some element B as referentially identical to an element A ('My cousin is John'), or to attribute a certain description to this element ('My cousin is an unemployed worker'). Hence the contrast between identificational and predicative sentences.²⁴ A lexical item that has such an operation as its special meaning is called a copula. Copulas are frequently verbs, like English *be*, Portuguese *ser*, Manjaku *ci*, or Mandinka *mu*. They may also be realized as non-verbs of unclear categorial status, such as Wolof *la* (see Sauvageot 1965; Njie 1982; Kihm 1991). And of course, they may be unrealized, at least in some cases, as in Russian or Modern Hebrew. The following examples seem to classify Kriyol along with these latter languages:

- (66) Kabra i amigu di kacur. (I)
 goat it friend of dog
 'Goat is Dog's friend.'
- (67) Kila i ka baka, i lyon. (I)
 that it NEG cow it lion
 'That's not a cow, it's a lion.'
- (68) Ami i karpinteru. (AK)
 me it carpenter
 'I am a carpenter.'
- (69) I kin? (AK)
 s/he/it who
 'Who is it?/Who is s/he?'
- (70) Omi ki la na fala u. (I)
 man who there A tell you
 'The man who's there will tell you.'

Notice that (66) may be understood as identificational or predicative, depending on whether ‘Dog’s friend’ counts as a label or a description. (67) and (68), on the other hand, are clearly predicative, while (69) is identificational, and (70) shows that the predicated description may also be a deictic locative specification (see below). These sentences have five features in common: (i) there is no overt copula; (ii) even with a full NP subject a subject pronoun must be present, resulting in a dislocated construction;²⁵ (iii) the subject pronoun is always 3rd person singular, even when the topicalized subject is a 1st person singular topic pronoun as in (68), or a plural NP, or any other topic pronoun including 3rd plural; (iv) the Tense of the sentence, i.e. the interval of time during which the identification or predication is valid, is Present, either actual Present as in (70), or generic Present as in the other examples; (v) aspectual auxiliaries cannot head nominal predicates (e.g. **ami i/n ta karpinteru*).

Consider now the following examples:

- (71) Bu ka na sedu no amigu nunka. (AK)
 you NEG A be our friend never
 ‘You’ll never be our friend.’
- (72) I na sedu kin ki na fasi kil tarbaju. (AK)
 it A be who that A do that work
 ‘Who will it be that will do that work?’

When the interval of validity of the identification or predication is no longer Present but Future, an overt copula shows up, viz. aforementioned *sedu*, and it is dominated by an aspectual auxiliary. What if the interval is Past? The two possibilities already indicated for adjective predicates are found here too. Both are successively realized in the following recorded example:

- (73) Pa ley i yera un prosesu... ley i un prosesu ba... un tarbaju
 for read it be+PAST a process read it a process PAST a work
 difsil. (I)
 difficult
 ‘Reading was a process... it was a process... a hard job.’

The speaker of (73) hesitates, corrects himself, and successively employs both ways of marking a noun predicate as past: (a) with the Past variant of the copula (to which *ba* could have been added); (b) without a copula, postposing *ba* to the noun predicate. Both constructions are denotationally identical. That without a copula is generally considered ‘deeper’ than that with *yera* (*ba*). The latter, however, may not in any way be assessed as ‘decreolized’, nor is the former archaic in the least. Both alternate, sometimes at a few centiseconds intervals as in (73), according to conditions which I prefer not to try to elucidate.²⁶ Obligatory dislocation and the constraint on the subject pronoun, of course, are again features

of copulaless constructions. The consequences are especially obvious when the NP subject is a topic pronoun. Observe the following pattern of grammaticality:

- (74) Abo i/*bu karpinteru ba. (AK)
 you(TOP) it/*you carpenter PAST
 'You were a carpenter.'
- (75) Abo bu/*i yera karpinteru. (AK)
 you(TOP) you/*it be+PAST carpenter
 'You were a carpenter.'

To sum up, noun predicates without a copula exist only in the Present and Past in Kriyol. In the Past, an alternative construction with an overt copula is found. Only in the Future is the use of a copula necessary. (Recall that by Present, Past, and Future, I mean the temporal location of the validity interval of the identification or predication, i.e. a truth domain, not a grammatical tense.) This makes noun predicates quite similar to the non-basic type of adjective predicates, which also respect, or so it seems, the person constraint. Compare, e.g., (68) with (76):

- (76) Ami i/?n demokratiku ciw. (I)
 I(TOP) it/?I democratic much
 'I am quite democratic.'

In turn, (76) should be contrasted with (77):

- (77) Ami n/*i kontenti. (AK)
 I(TOP) I/*it happy
 'I am happy.'

All these facts may be brought together given a few assumptions. Let us assume that Kriyol basic adjectives are indeed adjectives, i.e. [+N +V] items. In Portuguese or in English, adjective predicates bear a [+PRD] (predicative) feature selected by the copula, thus allowing for, e.g., *Sou contente* or *I am happy*. Let us assume that this feature is freely assigned to all Kriyol [+N] items, whenever they assume the semantic role of predicate. This is enough to authorize sentences such as (77), which we shall therefore represent as:²⁷

- (78) S[+FIN]
 NP (n)
 AP[+PRD]
 H[+N +V +PRD] (kontenti)

The semantic interpretation associated with (78) is straightforward: **kontenti**'(n*)'. Note that (78) is fully consonant with the Head Feature Constraint (HFC) given the notion of free feature specification (see Gazdar et al. 1985:95) and the fact that [+N +V +PRD] is an extension of [+N +V]. On the other hand, the node dominating a [+N] head could not be VP since (i) this would contradict the X-bar convention and the HFC in case the same head is also [-V], i.e. a noun

predicate; (ii) more seriously, we saw that Ad-verbs exclude noun predicates, which is not accounted for if [+N] heads can come under VP.

The aspect verbs **na** and **ta** are auxiliaries, which I shall simply take as meaning that they subcategorize for [+V] items, [+V] being equivalent to [uN +V] (with *u* meaning ‘undefined’ as previously); **n na kontenti** ‘I’m becoming happy’ can thus be generated. [PRD] assignation does not take place, then, since the adjective is no longer the head of VP, but [-N +V] **na** is. The adjective can be simply considered a verbal, non finite complement of the auxiliary. Neither does [PRD] assignation occur, of course, when the adjective modifies a noun as in **bajuda kontenti** ‘the/a happy maiden’, which simply receives the ordinary (NP(N1(AP))) structure. This explains why **bajuda kontenti** cannot mean ‘The fact that the maiden is happy’, for the simple reason that **kontenti** is not a predicate, i.e. not a function from NPs to sentences, but a modification, i.e. a function from NPs to NPs.

Free assignation of [+PRD] will also take care of all predicates consisting of non basic adjectives and nouns, or of locatives as in (70). To limit ourselves to the simplest case for the time being, **i karpinteru** ‘S/he (is) a carpenter’ is thus analysed as:

- (79) S[+FIN]
 NP (i)
 NP[+PRD]
 H[+N -V +PRD] (karpinteru)

with the semantic interpretation **karpinteru**’(i*). NP[+PRD] are thus functions from NP to S, so there is, as desired, a semantic equivalence between VP-type objects and noun predicate-type objects. Note, however, that no unification is feasible between VP with feature values [<N,-> <V,+>] and NP[+PRD] with the opposite values for the same features (for unification, see Gazdar et al. 1985; Shieber 1987). VP and NP[+PRD] are thus in effect distinct categories. NP[+PRD] and AP[+PRD], on the other hand, can be partially unified, provided the feature value for V remains undefined; and the same for AP[+PRD] and VP provided the feature value for N remains undefined. The ‘intermediate’ categoricity of adjectives is thereby highlighted.

Since nouns are [-V] and, I assume, non basic adjectives are too, it follows that neither can be selected by the aspectual auxiliaries (see above).²⁸ A copula must therefore be used whenever the predicate is given some special aspectual value, resulting in structures like the following for, e.g., **i na sedu karpinteru** ‘S/he will be a carpenter’ and **i yera karpinteru** ‘S/he was a carpenter’.²⁹

- (80) S[+FIN]
 NP (i)
 VP[+AUX]
 H[+AUX, Ai] (na)
 VP[+PRD]
 H[COP] (sedu)
 NP[+PRD] (karpinteru)
- (81) S[+FIN]
 NP (i)
 VP[+PRD,+PAST]
 H[COP,+PAST] (yera)
 NP[+PRD] (karpinteru)

Finally, recall FCR (40) which guarantees that finite sentences with or without an aspect verb always receive an aspectual interpretation. ‘Bare’ adjectival and nominal predicates are finite sentences as well, so they receive a temporal interpretation — i.e. a truth value along certain coordinates of the time dimension — as will be shown at length in the following.

There remains for elucidation the differential constraints on the person of pronominal subjects. The issue has to be deferred until a later section, though, since it involves the syntax and semantics of pronouns and of topicalized constructions (see Chapters 4 and 6).

Before concluding this point, it is useful, I think, to briefly compare Kriyol with the surrounding, superstrate and substrate languages, given that noun predicates are indeed a characteristic feature of the language. Noun predicates without a copula are naturally impossible in Portuguese, since, as suggested, [PRD] is never freely allocated in this language, but only to complements of designated items, viz. copular verbs. Remember, however, the well-known fact that Portuguese has two copulas, *ser* and *estar*, the contrast between which may be considered aspectual. This contrast is reflected in Kriyol, as will appear.

Substrate languages, on the other hand, are equally devoid of copulaless constructions, to the best of my knowledge. Nominal predicates, and the ‘liberation’ of the [PRD] feature, seem then to be a Kriyol innovation.

2.3. Negation

In this section, I will only consider the negation of VPs, leaving for later examination such ‘non local’ issues as the scope of the negation outside its clause, negative concord, and negative words meaning ‘nobody’, ‘nothing’, ‘not even

(**nin**), etc. which always trigger negative concord. The following examples include all the evidence we need for the moment:

- (82) Ze ka riba inda. (AK)
 Ze NEG return yet
 ‘Ze hasn’t returned yet.’
- (83) Bu ka na pati n el? (I)
 you NEG A offer me it
 ‘Won’t you offer it to me?’
- (84) I ka lyon i baka. (I)
 it NEG lion it cow
 ‘It isn’t a lion, it’s a cow.’
- (85) Naw i ka so kriyol ku n papyá. (I)
 no it NEG only Kriyol that I speak
 ‘No, it’s not only Kriyol that I speak.’³⁰

Negation in Kriyol is expressed by the morpheme **ka**. This morpheme immediately precedes the first component of the VP[-SUBJ] (82-83), or the first component of a noun or adjective predicate (84-85).³¹ Finally, predicate negation in Kriyol is formally distinct from what may be called the autonomous negation, which marks Kriyol off from its lexifier — compare (85) with the Portuguese equivalent *não, não falo só crioulo*.³²

As a first approximation, these facts may be captured with the following metarule:

- (86) XP[+PRD] → H[n], W ⇒ XP[+PRD,+NEG] → ka[+NEG], H[n], W

The left part of (86) is a rule schema over all lexical predicate-forming ID rules. What the metarule says is that to each lexical ID rule rewriting XP[+PRD] (i.e. VP or NP/AP[+PRD]) as a head and a variable string, there corresponds a rule rewriting the same XP as a head and a variable string and the negative item **ka**. The problem now is that of the position of **ka** relative to the XP[+PRD] it modifies, and the solution depends crucially on the lexical identity of the item. The easy way would be for us to assume an LP rule like the following:

- (87) [uBAR, +NEG] < [BAR 0, {-N +V} ∨ +PRD]

That is, the negative item — analysed as a minor category undefined for bar level — precedes a zero-level item that is either a verb or a noun or adjective predicate. This would account for the orderings observed in (82-85), although it does not make clear why the negative item should precede the first verb in the sequence, why in other words ***bu na ka pati n el** (see (83)) is as utterly ungrammatical as it is. We would have to complexify (87), adding [+AUX] to {-N +V}, with the understanding that if the first verb fails to be [+AUX] as in (82), then the rule applies all the same since [-N +V] is a proper subset of [-N +V

+AUX]. But we still have a problem when several verbs in the sequence are [+AUX]. Again the negation comes first, and one must say, e.g., **no ka na ba ta skirbi I** 'we shall not write it (henceforth)', not ***no na ka ba ta...**, or ***no na ba ka ta...** This is not easily expressed by a rule of the type of (87).

Moreover, recall that, in (87), **ka** is construed as a minor category, i.e., presumably, a particle. This is a problem, because minor categories are undefined for bar level, which implies that they cannot be heads, but we want the feature [+NEG] to percolate up to VP level. Such percolation could be effectuated by having **ka** stand in specifier position, like a determiner, so that the negative feature would extend to the sister V1:

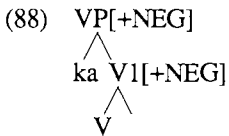

One fact that seems to favour this analysis is that **ka** constitutes one phonological word with a following aspectual auxiliary or monosyllabic verb: [kána], [káta], [kábay] ('didn't go').³³ The condition 'aspectual auxiliary or monosyllabic verb', which can be reduced to 'monosyllabic verb' *tout court*, however, makes me suspect that the process is a purely phonological one, which shouldn't be supposed to reveal anything about the syntactic structure of the sequence.

As a particle **ka** would have to be a verbal particle in any event, in the sense that, as already mentioned in the section about adjective predicates, it subcategorizes for XP[+PRD], not for non predicative NPs. Note, for instance, that **i ka lyon** does mean 'It is not a lion', not 'It is a non-lion' (a meaning (?) that is unexpressible using pure Kriyol resources). Similarly, one cannot say ***n oja un ka lyon**, meaning something like 'I saw a thing that was not a lion'.³⁴ But what shall we do, then, with examples (89) and (90) where **ka** seems indeed to subcategorize for S (or VP[+SUBJ])?

(89) **Ka bu torna cora mas.** (I)

NEG you do-again cry more
'Don't cry any more!'

(90) **I na disfarsa pa ka i sibi.** (I)

s/he A pretend for NEG s/he know

'She is pretending in order for him not to know.'

Perhaps we might generate **ka** in the position of specifier of S. But this is the position that the complementizer **pa** occupies in (90) and, in the framework adopted here, there is no room for anything like a specifier of Comp, given the

absence of bar levels for minor categories. Observe, moreover, that (89) and (90) are not provided for by the LP statement (87), so we would either need another LP statement just for this case, or (87) would have to be complexified considerably.

An alternative analysis obviates all these difficulties, viz. to consider **ka** a verbal item, more precisely a negative auxiliary belonging to the class of Ad-verbs. As a consequence, the negation will no longer be introduced via a metarule (a dubious solution in any case), but through its own lexical ID rule:

(91) VP[-SUBJ,+AUX,+FIN,+NEG] → H[+NEG], XP[+PRD] (ka)

Rule (91) describes one environment in which **ka** appears, namely VPs or noun or adjective predicates heading autonomous sentences. As usual, XP[+PRD] in (91) spans VPs headed by a [+/-AUX] verb and, as already mentioned, NPs[+PRD] headed by a noun, as in (84). Now this is a difference with other Ad-verbs, which all subcategorize for [+V] items. There is thus a justification in having a special rule for the negation.

Note that an alternative solution one might think of, viz. considering **ka** a negative copula in sentences like (84), will obviously not do. First, we would then have to deal with two homophonous **ka**, depending whether the negated predicate is verbal or nominal. Secondly, the evidence runs counter to this solution insofar as aspectually modified negated or non negated noun predicates behave exactly alike, i.e. a verbal copula must appear, so that the prospective equivalent of (84), e.g., would be *i ka na sedu lyon* 'It won't be a lion'. Such sequences as **i ka na lyon* or **i na ka lyon* are totally excluded.

With **ka** a verb, part of the ordering problem raised above simply vanishes. Indeed, there is a subcategorization relation between H [+NEG] and XP [+PRD] in (91), so the fact that **ka** must precede the first predicate head in the sentence is directly accounted for by the general LP rule [SUBCAT] < ¬[SUBCAT]. This explains, incidentally, why **ka**, while being an Ad-verb, is never modified by an aspect auxiliary. It is simply because the negation must always precede the whole predicate, and aspect auxiliaries belong to the predicate.

What about (89) and (90) then? Let us first take (89). It is a negative imperative sentence. Imperative sentences have already been alluded to, and this as good a place as any to say a bit more about them, since, apart from the present problem, there is no compelling reason for setting up a special section for 'mood' in Kriyol.

Firstly, a distinction ought perhaps to be made between 'imperative' and 'injunctive', as evidenced by the following examples:

(92) Pega baka li. (I)
 tie cow here
 'Tie the cow here!'

- (93) No bay. (AK)
 we go
 'Let's go!'
- (94) Kin ku tene orejas pa i obi diritu. (V)
 who that have ears for he hear well
 'He who has ears, let him hear well.'

Imperative sentences — i.e. sentences using a characteristic intonation and directed at one or several possible agents (persons, animals, etc.) in order to have them become the actual agents of the process denoted by the head of the sentence — appear as subjectless bare verbs in Kriyol (see (92)). At least this is so unless the speaker includes him/herself in the possible agents as in (93), in which case the subject pronoun *no* 'we' is used, and the sentence is formally identical, but for the intonation, with an aspectually unmodified finite sentence. Note that the reason for considering (93) an imperative sentence like (92) in spite of the formal difference is that (a) the same intonation is used; (b) similar pragmatic conditions make the sentence felicitous or not in both cases — e.g. that the speaker should be entitled to giving orders. True, similar pragmatic conditions may also be said to hold in (94). But the intonation is different, and it is not presupposed, as it is in (92) and (93), that the process should be accomplished right following the utterance. For this reason, I will consider (94) an instance of an injunctive, rather than imperative sentence and delay its examination until later on. Formal and semantic considerations ensure that the distinction is not a purely terminological one.

Let us assume that in imperative sentences, the person of the implied, unexpressed subject has the obligatory value 2, singular or plural — since *bay* 'Go away' can be addressed to one or several persons. An FCR tying the feature [+IMP] with [AGR, 2] would seem to be the right way of capturing this restriction. I will prefer a meaning predicate approach, however, since it is after all a semantic issue that the (virtual) argument of whom an imperative verb is predicated necessarily includes the addressee (which includes inclusive 'we' as in (93)). Hence (95) where *N* reads 'necessarily', *ADREE* means 'addressee', and *P* is a variable over NPs:

- (95) MP: $\forall VP N[VP<+IMP>(P) \longleftrightarrow VP<+IMP><AGR,ADREE>(P)]$

Recall that the presence of the feature [+IMP] is perceptible through the characteristic intonation of imperative expressions. MP (95) is of course inapplicable should an overt subject with person features different from 2 be present under the *S* which dominates the *VP*. The following local tree is thus generated:

- (96) S[+FIN,+IMP]
 VP[+FIN,+IMP]

This is a subjectless sentence.³⁵ However, the identity of the implied subject can be recovered thanks to the feature [+IMP] and MP (95). In other words, the subject is, in a sense, incorporated into the VP, as in so-called ‘null subject’ languages.³⁶

To return to the position of the negation in (89). Given the preceding, we might simply assume that **ka** in **ka bu torna cora mas** is an imperative. Imperative **ka** then dominates a sentence which does not receive the feature [+IMP], hence cannot appear with a null subject. The first part of the solution won’t work, however, because it would lead us to expect ***no ka no bay** as the negative equivalent of (93), with ***no ka** parallel to **no bay**, whereas what we find is **ka no bay** ‘Don’t let’s go!’. To understand what is going on, we must in fact look at (90) and (94). Remark first that the negation of (94) is [...] **pa ka i obi diritu** ‘let him not hear well’. This suggests that, whatever the precise structure of (90) and (94) — to be examined later on —, **ka** in (89) is not an imperative, but an injunctive, and that the subject of the negative injunctive sentence (i.e. of the local tree headed by injunctive **ka**) is always left unexpressed.

Informally, then, **ka bu torna cora mas** should be glossed ‘Be it not (that) you cry again!’. A question now is why does complementizer **pa** not appear in (89)? A partial answer is that it may appear, and that **pa ka bu...** is slightly distinct from **ka bu...** inasmuch as **pa ka bu torna cora mas** means something like ‘You’d better stop crying’.³⁷ An interesting observation follows, namely that, in Kriyol at least, there is no negative imperative, only a negative injunctive corresponding to a positive imperative. Intuitively this makes sense and is paralleled by similar facts in other languages — see, e.g., the use of the subjunctive in negative orders and optative sentences in Portuguese. I won’t go any farther on this topic, though.

2.3.1. *The origin of ka*

This is an interesting topic insofar as **ka** provides one of the clearest examples of the role of conflation in the origin of a creole language (on lexical conflation, see Kihm 1989). As mentioned earlier, Kriyol diverged crucially from Portuguese when the all-purpose negative particle *não* of the latter, having changed to **naw**, was limited to the function of a negative sentence word (‘No!’), and the verbal item **ka** took its place in negated predicates. Where did this new item come from?

If one looks for a Portuguese etymon, the only plausible one appears to be *nunca* ‘never’, reduced to its second syllable. It is true that *nunca* is used as a predicate negation in some of the Asian Portuguese-based Creoles (see, e.g., Dalgado 1900), and it also shows up with this function in the literary renditions of the 16th century *lingua de preto* (see Teyssier 1959; Kihm 1992b).³⁸ The phonetic

change from /'nunka/ to /ka/ makes difficulty, however, as Kriyol seems to have retained the unstressed syllable rather than the stressed one. The change in lexical category is also not readily explained with this etymology. This is what makes crucial the observation that a number of surrounding languages have negative items whose phonetic shapes include segments identical or very similar to /ka/. In Mandinka, we find what Rowlands (1959:74ff.) terms negative tenses expressed by the morphemes *buka* ('Simple Imperfective Indicative'), *kana* ('Imperative, Subjunctive, 'Si' Indicative'), and *kaka* ('Imperfective Imperative'). Examples are *m búk'aa dómo* /we NEG+ASP it eat/ 'We do not eat it', or *íte kána wúli* /you+EMPH NEG+ASP get-up/ 'Don't you get up' (p. 89). Manjaku has two negative morphemes with a /ka/ segment, viz. *dika* for the unaccomplished — *m dika ran* /you NEG+ASP drink/ 'You won't drink' — and *kats(a)* meaning 'no longer' — *ucaak katsa niua* /town no-longer build+PASS/ 'The town was no longer built' (Buis 1990:41-42). Similarly, one of the allomorphs of the negation in Balanta is represented by a morpheme /kë/ (Wilson 1961). Not only are those morphemes phonetically close to the Kriyol negation, they all amalgamate some kind of aspectual denotation with the negative expression they convey, so they have to be analysed as negative auxiliaries rather than as simple negations. Correlatively, all the languages mentioned present different items for the sentence word meaning 'No!' and for the predicate negation. I will therefore assume that the presence of such items in the linguistic environment of incipient Kriyol was decisive in forcing the phonetically unusual change of /'nunka/ to /ka/, as well as in channelling the lexical and syntactic change whereby *ka* became a negative auxiliary verb.

2.4. The arguments of the verb

Here, I will examine those terms which are linked to the verb by the grammatical relations 'subject of', 'direct object (DO) of', and 'indirect object (IO) of'. The definition I will use for these relations is that of Gazdar et al. (1985):

- (i) The subject is that term which combines last of all with a verbal phrase to make a sentence. (ii) The direct object is that term which combines with the verbal phrase immediately before the subject term. (iii) The indirect object is that term which combines with the verbal phrase immediately before the direct object term. (p. 198)

The sequencing indicated in the definition is not to be understood as corresponding to some ordering of syntactic operations, in the spirit of transformational grammar. It expresses the semantic principle according to which a verb taking *n* arguments as fits its meaning actually combines with these arguments in order to yield a full proposition, i.e. something whose semantic type belongs to the domain of truth values. For example, a V3 (or ditransitive verb) combines with an IO to yield a V2 (or transitive verb), which combines with a DO to yield a VP, which combines with a subject to yield an S, i.e. a saturated verbal expression. As we shall see, Kriyol provides a striking confirmation of such a combination principle.

It is a matter of much debate whether verbs (or predicate heads) subcategorize for their subjects as they do their complements (see Sells 1985 for a summary of the discussion). I will have nothing to say about this, except to mention that there is in Kriyol — and in many other languages — a special class of verbs which do select their subjects in a very precise way, the so-called weather verbs (see Ruwet 1986, 1989). For reasons that will appear presently, I prefer to call them environmental verbs. Our review of verb arguments will open on them.

Another hot area in studies about subjects is that of null and expletive subjects. It is indeed represented in Kriyol as evidenced by **falta puku karu maja l** /lack a-little car hit him/ 'A car nearly hit him', **parsi n kuma...** '(It) seems to me that...', **i ten arus** /it have rice/ 'There is rice' vs. **arus ten** /rice have/ 'id.', and so forth. As these examples show, expletive and null are closely linked in Kriyol, and the issue involves a good deal of argument shuffling. This is why I won't tackle it here, although it wouldn't be against the logic of the exposition if I did, but will postpone it until Chapter 6. If it seems I'm nevertheless broaching the subject in what follows presently, it is only because the threads of language are impossible to unravel in a constantly neat way.

The argument terms that combine with a verb are of TYP(NP). That is, they denote sets of sets of individuals in the sense that, e.g. 'some linguists' denotes a set within the set of individuals who have the property of being linguists in some world. Sentences qualify as possible arguments insofar as they are produced by a function from TYP(NP) terms. In their case, 'set of individuals' may be translated as 'set of instances of being the case that'. Sentential objects, as they belong to the syntax of embedding, will not be dealt with in the following. Sentential subjects, in contrast, will detain us awhile, because their existence and characterization poses problems in Kriyol.³⁹ Having thus extracted, or so I hope, nearly all interesting facts about subjects in Kriyol, I will then proceed to examine nominal arguments within the VP. Although direct and indirect objects *per se* deserve no special comments, Kriyol presents a double object construction as well as a construction

involving apparently unaffected objects which are worth exploring.⁴⁰ Subcategorized PPs will also be briefly examined. Finally, broadening somewhat the notion of argument, we will have a look at phrasal adjuncts and at adverbs, especially so-called ideophones and sentential particles. This will close this chapter on the simple sentence.

2.4.1. Selected subjects of environmental verbs

As in many, if not all, languages, Kriyol verbs denoting states of the physical environment present a few syntactical peculiarities which set them apart. The following examples contain nearly all such verbs as far as I am aware: **sol noti** 'The sun is setting'; **sol mansi** 'The sun is rising'; **sol na firiya** (or **friya**) 'The sun is declining' (literally 'cooling'); **cuba na cubi** 'It's raining'; **bentu na supra** 'The wind is blowing'; **relanpagu fasi** 'There was a lightning'; **kaw na sukuru** 'It's becoming dark'; **kaw kinti** 'It's hot'; **kaw firiya** 'It's cold'; **kaw kala** 'It's quiet'; **i na burfa** 'It's drizzling'.

Three groups may be distinguished. In the first group, a noun denoting an object of the astronomical or meteorological environment, viz. **sol** 'sun', **cuba** 'rain', **bentu** 'wind', and **relanpagu** 'lightning', is associated with a particular verb in a stable collocation. **Noti**, obviously related to the noun **noti** 'night', might be glossed as 'turn to night', and it is encountered only in this expression, thus implying that the only thing in the world which may **noti** is the sun. I will therefore vouch for a strictly lexical analysis of this case, one in which the lexical matrix of **noti** simply includes the specification that its subject must be **sol** (see Pollard & Sag 1987:129 for a possible representation).⁴¹

Formally similar to **noti**, there is **notisi** or **notsi**, from Portuguese *anoitecer* 'to become dark'. Actually, **notisi** means something like 'go towards night', i.e. 'spend the day' as in **n na notsi na Kacew** 'I'll spend the day in Cacheu' (Doneux & Rougé 1988:25).⁴² Its converse is **mansi**, from Portuguese *amanhecer* 'to dawn', which means 'go towards day', i.e., as one possible interpretation, 'spend the night'. The first reading is retained when **sol** is the subject. The difference with the preceding case **noti**, though, is that **mansi** is not restricted to one lexical subject (e.g. **kil camidur ta mansi na klando** 'That drunkard spends his nights in clandestine bars' — Gomes & Mendonce 1981). It seems, then, that the meaning alternation constitutes the componential effect of combining **mansi**'s basic semantics (probably 'go towards day') either with **sol** or with any other sensible subject. In fact, **sol** is probably the only inanimate subject that **mansi** accepts. If that is so, there is little reason for applying to it the same solution that we adopted for **noti**, as this would now imply setting up two lexical entries for **mansi**,

mansi[+sol] and **mansi**[+Animate], in spite of the obvious semantic commonality between both uses.⁴³ The question, to which I have no answer, is rather, why do we find a formal distinction of **noti** vs. **notisi** in one case, but none in the other? In any case, the syntactically interesting piece of information is the existence of a very specific link between those verbs and their subjects.

Cubi 'to rain' belongs to the same file as **noti** insofar as it too accepts only one subject, i.e. **cuba** 'rain'.⁴⁴ On the other hand, **firiya** 'to cool', **sopra** 'blow' and **fasi** 'make/do' are ordinary verbs as far as subject admissibility is concerned, so they rather pattern with **mansi**. (For the 'middle' value of **fasi** in **relanpagu fasi**, see Chapter 7.)

The next four examples form a second group where the environmental meaning of the expression is a direct function of the use of the particular subject **kaw** 'place'. **Kaw**, probably from Portuguese *cabo* 'cape' via a maritime metaphor, belongs to the category of generic, quasi pronominal nominal expressions of which English 'this person', 'that thing', or qualifying nouns like 'the bastard' are examples (see Ruwet 1982). It appears in such expressions as **bira na un kaw** 'turn on oneself', **kaw di sinta** 'chair' (lit. 'place of sitting'), **bari kaw** 'to sweep (the place)', etc. Its defining feature, here and in the environmental expressions listed above, is intrinsic deixis, in the sense that, unless explicit indication to the contrary is given, the 'place' referred to has to be 'this place' where the speaker is.⁴⁵ Given this character, I will assume that **kaw**, in addition to being a normal NP, belongs to the small group of especially marked NPs. That is to say, its lexical entry is something like <*kaw*, NP([PRO, NFORM *kaw*])...>, with the special marking optional. The verbs and predicative adjectives **sukuru** 'dark', **kinti** 'hot', **firiya** 'to cool', **kala** 'be quiet', on the other hand, will have their mother VPs optionally marked with a [AGR NP[NFORM *kaw*]] feature in order to signal that they may combine with 'special' **kaw** as a subject, thereby assuming an environmental meaning.⁴⁶ The other item like **kaw** is expletive **i**, to be studied at length in Chapters 4 and 6.

Finally, **i na burfa** 'It's drizzling' (P. *borrifa, está a borrifar*) along with **i na cubi** (see fn. 44), forms a third group of expressions constructed in the same way as their Portuguese or English equivalents, i.e. verbs agreeing with a special expletive item, **i** in Kriyol, a null element in Portuguese.

2.4.2. Sentential subjects

One example of what might look like an instance of a sentence with a sentential subject has been encountered earlier, viz. (73), repeated below in a shortened version, and to which I add another example of the same kind:

- (97) Pa ley i yera (...) un tarbaju difisil. (I)
 for read it be+PAST a work difficult
 'Reading was a difficult job.'
- (98) Pa manda karta i ka tene. (I)
 for send letter it NEG have
 'For sending a letter, there is nothing.'

However, a little scrutiny is enough to realize that those are in fact instances of topicalized complement sentences, and the actual subject of the matrix clause is the 'reprise' pronoun *i*. Their analysis pertains thus to the domain of Unbounded Dependencies, to be entered later on. More to the point, it seems, are the following examples:

- (99) Tene tiw bon. (I)
 have uncle good
 'It's good to have an uncle.'
- (100) Punta pa sibi bon. (MJPB)
 ask for know good
 'Asking in order to know is a good thing.'
- (101) Nya omi, sibi ku disi na mata l. (MM)
 my man climb-up with climb-down A kill him
 'My man, (all this) climbing up and down will kill him.'

Three possibilities present themselves as to the categorial identity of the phrases **tene tiw**, **punta pa sibi**, and **sibi ku disi**; they might be either VPs, or NPs, or Ss.

The first possibility can be dismissed right away on principial as well as material grounds. Indeed, VPs are functions from NP(TYP) objects to S(TYP) objects, i.e. from expressions denoting the property of being some entity in some world to expressions denoting a true or false proposition about these entities. NPs are thus arguments of propositions (or of functions), and Ss can be arguments of more complex propositions, i.e. propositions about propositions (compare *The sky is always blue somewhere* with *That the sky is always blue somewhere is true*). VPs, in contrast, as functors on NPs or NP-like objects, i.e. on arguments, cannot be arguments themselves as a matter of principle (cf. **is always blue somewhere is true*).⁴⁷

The factual observation that goes with this argument is that the problematical phrases of (99-101) do not indeed behave like VPs are supposed to in Kriyol. They cannot be modified by aspectual auxiliaries or Ad-verbs, so that, e.g., ***na tene tiw bon** or ***bin tene tiw bon** are impossible (meaning something like 'Having a future uncle is good', in a situation where one's aunt is about to marry). Neither can the past marker be suffixed to them (see Chapter 3), and **tene ba tiw bon** or **tene tiw ba bon** cannot be produced to signify 'Having had an uncle is good'.

Clearly, however, **tene**, **punta**, etc. are verbs subcategorizing for complements in a way that nouns do not (compare **i falta n tiw** lit. 'It lacks me an uncle' with **nya falta di tiw** 'My lack of an uncle'). This precludes analysing these items as nominal forms, except perhaps in the sense that the infinitive can be so analysed in the (not too colloquial) Portuguese equivalent of (99), viz. *ter um tio é bom*. But this takes us to the third and, I think, correct solution.

The crucial observation is that the verbs at issue do imply subjects. In (99) and (100), the logical subject may be said to be generic or 'arbitrary', although it is certainly not indeterminate, insofar as (99), for instance, may be translated as: $(\forall x$: human being, x)(have an uncle, x) be good). Only humans (and humanized animals) have uncles, by definition. In (101), on the other hand, the logical subject of **sibi ku disi** is obviously **nya omi**, not somebody else whose inconsiderate activity might somehow kill **nya omi**. I will therefore propose the following translations for the subjects of (99) and (101):

(102) λx [tene (tiw)(x)] & x = Human being

(103) λx [sibi-ku-disi (x)] & x = **nya omi**

It is by virtue of being associated with such translations that **tene tiw** and **sibi ku disi** must be considered sentences. Non finite sentences to be precise, insofar as they do not denote some instance or series of instances of the process denoted by the VP that heads them, but merely the denotation itself ('having an uncle', 'asking', and so forth). The exclusion of all aspectual modification, particularly the perfective interpretation resulting from FCR (40), is thus explained.

There is thus no question of a 'null subject' in the syntactic form, which does not have to be different from what is actually perceived. Once again, the whole point resides in the proper interfacing of semantics and syntax. In the case of (99), for instance, the two planes can be partially associated as in (104):

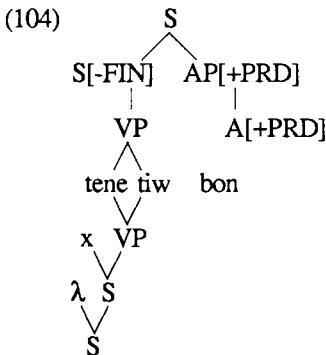

Obviously, there must be a correlation between the non-finiteness of such sentences and their inability to accept overt subjects. It is to be found, I think, in the fact that non finite sentences such as *tene tiw* are not actually S-type objects, but rather NP-type objects denoting properties of concepts, here, e.g., the property of having an uncle, as developed in (102) above. The argument is readily extended to non finite sentences functioning as arguments of modal or auxiliary verbs (e.g. *n misti tene tiw* 'I want to have an uncle'; *n yara tene tiw* 'I almost had an uncle' — see Gazdar et al. 1985:86). However, we need a semantic principle to govern the fact that (99) and (101) imply subjects which are differently, but invariably interpreted, as the class of human beings in the first example, as the topicalized constituent in the second one. Control as defined in Gazdar et al. (1985:204) won't do, since we are not in a proper syntactic configuration for the Control Agreement Principle (CAP) to be activated (no controller in the constituent S or VP). I therefore propose a meaning postulate reading as follows (with N meaning 'necessarily' as before):

(105) MP: "VP N[VP<FIN,->(P) <—> VP<FIN,-><AGR x>(P)] & x = X(TYP(NP)) or x = NP_i, & NP_i = INP[VP(NP)]

MP (105) will be resorted to just in case no principle like the CAP permits us to interpret the implied subject of the non finite sentence correctly. What it says is that, in such a case, the implied subject must be either some unspecified type-NP item compatible with the meaning of the VP,⁴⁸ or a specific NP that is known to be the subject of the VP, and that is present in the immediate (as in (97)) or distant discursive environment of the sentence.

More or less as a consequence of this argument, it does not seem legitimate to impose limitations on what verbs may take sentential subjects in Kriyol. It is a fact that adjective predicates of the evaluative type (*bon* 'good', *fiw* 'ugly', and so forth) are frequent favourites. But take (101); any verb could follow the coordinated sentential subject *sibi ku disu*. Naturally, not all verbs make sense, but neither would they after an ordinary NP subject (compare *sibi ku disu na suta I* 'Climbing up and down will knock him' with *kasa na suta I* 'The house will knock him'). This is clearly a matter for local and general semantics to decide, not for a particular rule about the possible combinations of verbs and subjects.

Finally, the NP-typehood of non finite sentences is clearly borne out by their accepting the same determinants as 'ordinary' NPs do, i.e. possessives (*si sibi ku disu na mata I* 'His climbing up and down will kill him') and demonstratives (*kil sibi ku disu na mata I* 'This climbing up and down will kill him'), which makes the Kriyol unmarked verbs look very much like English gerunds. Since there is no necessity for distinguishing infinitives from gerunds in Kriyol, nothing justifies, I

think, that we should introduce an NP node in the structure. So I will represent, e.g., *kil disi ku sibi* simply as follows:

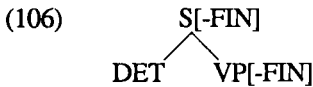

The semantic definition of S [-FIN] makes such a structure acceptable without more ado.

2.4.3. Double object constructions (DOC)

Many verbs in Kriyol subcategorize for two objects in a sequence. Here are a few examples:

- (107) *Mininu manda si mame un karta.* (AK)
 boy send his mother a letter
 ‘The boy sent his mother a letter.’
- (108) *Si bu bay fera konpra bo tiya sinku kilu di arus.* (AK)
 when you go market buy your aunt 5 kilo of rice
 ‘Buy 5 kilos of rice for your aunt when you go to the market.’
- (109) *Muru kobra nyu Sapu un bruta di pres.* (FJDM)
 Moor charge Mr Toad a brute of price
 ‘The Moor [i.e. the Muslim shopkeeper] charged Mr Toad a hell of a price.’
- (110) *E coki l mesinyu.* (K)
 they impair him poison
 ‘They impaired him with a poison.’
- (111) *Kila ningin ka pudi tuji n el.* (I)
 that nobody NEG can forbid me it
 ‘Nobody can forbid me that.’
- (112) *I ka na bin toma nu es kusa.* (I)
 he NEG A BIN take us this thing
 ‘He isn’t going to take this from us.’

The semantic domain of these verbs is rather usual, i.e. verbs meaning ‘give’, ‘send’, ‘take’, and so forth. In the simplest case — (107), for instance — one object corresponds to the goal of the process, and the other to the entity being moved from the subject to the goal. They are obligatorily ordered as in (107), first the goal, then the affected object. Notice that, when the second object is a pronoun as in (111), the topic or ‘detached’ form (see Chapter 4) must be used, since the pronoun is no longer adjacent to the verb, and clitic forms are therefore excluded.

However, it does not take more than those few examples to show that the semantic roles that the objects may play is rather varied. Clearly a goal in (107), the first object is more a beneficiary (or a victim) in (108-111). It is an origin in (112). Similarly, second objects oscillate between the status of affected object or

of some kind of instrument. Example (110) is especially interesting since, given the meaning of *coki* 'embarrass, impair', but also 'shut, put the lid on', one would be tempted to analyse the first object I 'him' as an affected object, and the second object *mesinyu* 'poison' as an instrument. I use lower case for all such notions because I am rather sceptical as to their cognitive relevance. It cannot be doubted, however, that, no matter which precise role they play, first objects are in fact more directly affected by, or more immediately participating in the process denoted by the verb than are second objects. Despite their traditional name of indirect objects, first objects are thus less oblique than second ('direct') objects, so that the relative ordering of the two is adequately described with the following LP statement taken from Pollard and Sag (1987:174):

(113) LP: COMPLEMENT << COMPLEMENT

where << means that the preceding (left-hand) element is less oblique than the following (right-hand) one.

To put it differently, *send-one's mother*, *charge-Mr Toad*, *buy-(for) one's aunt*, and so forth are, or may be construed as being tighter predicates than *send-a letter*, *charge-a hell of a price*, *buy-rice*, and so forth. As this is mostly a matter of viewpoint, variation across languages is to be expected (see Langacker 1987:320) In any case, Kriyol facts as they stand fully vindicate the definition of grammatical relations given earlier.⁴⁹ I will therefore make full use of this definition and replace the descriptive labels 'first' and 'second' objects by their functional translations 'direct' and 'indirect' objects respectively — not to be confounded with the traditional categories.

Slightly different from the DOCs examined so far are those constructions where the IO, most often a clitic pronoun, denotes an entity that is interested or involved in the process rather than directly affected by it. Here are two examples:

(114) Furtaduris lanbu l tudu. (I)
 thieves carry-in-one's-arms him all

'The thieves carried away everything he had.'

(115) N misti pa bu tira n es kamarada midida. (HGTD)
 I want that you draw me this comrade measurements
 'I want you to take this comrade's measurements for me.'

As shown by (115), such 'involved complements' may cooccur with a DOC, making it a TOC (T for 'triple'). Actually, the crucial element that distinguishes involved complements from the other types of first objects is the verb's meaning, and there is no denying that the distinction may be fuzzy at times. For instance, *lanbu* 'carry-in-one's-arms' (as against, e.g., *banbu* 'carry-on-one's-back'), does not seem to have the right kind of meaning to call for an indirect object it would

affect in the sense that *give* or *take away* affect their IOs. Similarly, in (116), *n* ‘me’ is not, I assume, in the sphere of the idiomatic VP *toma konta* ‘take possession’, but rather of the noun *lugar* ‘place’, and is thus involved in the event rather than directly affected by it.

- (116) Bu toma n konta di lugar. (HGTD)
 you take me possession of place
 ‘You took possession of my place.’

Note that an alternative formulation, closer to the English gloss, is possible, viz. *bu toma konta di nya lugar*, but not without loss of the ‘personal involvement’ shade of meaning. There is a clear intimation in (116) that I care for what you did. Again, the semantic-syntactic mismatch is easily resolved in the framework of the Autolexical hypothesis.

2.4.3.1. Possible origins for DOCs

Double objects are unknown in Portuguese, where (107) and (108), for instance, translate respectively as *O menino mandou uma carta à sua mãe* and *Se fores no mercado, vais comprar 5 kilo de arroz para a tia*, i.e. with the verb subcategorizing for what is in Kriyol the indirect object (IO), whereas the Kriyol direct object (DO) appears in a subcategorized or an adjunct PP. That is so, at least, unless the objects are pronouns, in which case they combine very much like in Kriyol. Compare *O menino mandou-lha* ‘The boy sent her it’ (*lha* = *lhe* <3SG, DATIVE>, meaning here *a sua mãe* ‘his mother’, + *a* <3SG, FEM, ACCUSATIVE>, meaning here *uma carta* (feminine) ‘a letter’) with *mininu manda-l el*, same gloss and same structure except for the ban on clitic combinations. Involved complements, represented by the so-called *pronomes de interesse* (Cunha & Cintra 1987:304-305), are not unknown in Portuguese either.

This might be one way through which DOCs crept into Kriyol, then generalized to non pronominal complements. One cannot reject the possibility, however, that the change or the generalization were motivated by the presence in some substrate languages of DOCs quite similar to what is found in Kriyol. Manjaku, for example, has sentences like *a piban natson banyan* /he introduce host people/ ‘He introduced the people to the guest’ (Buis 1990:54). Likewise, Balanta has *u das afula maa fmangaa* /you cut young-girl the cloth/ ‘You cut a cloth for the young girl’ (N’Diaye-Correard 1970:127). Other languages such as Diola-Fogny (Sapir 1969:101) or Mandinka (Rowlands 1959) lack these constructions, though. I will therefore remain cautious.

Double objects, example (110) in particular, are also interesting in that they introduce the issue of those (unique) direct objects whose relation to the verb cannot, it seems, be characterized by any sensible notion of affectedness.

2.4.4. *Unaffected(?) objects*

The following examples give an idea of what the dubious label above is supposed to cover:

- (117) Kil baka ka ta osa fugu. (I)
 that cow NEG A dare fire
 'That cow is afraid of fire.'
- (118) Nya pape ka seta n skola. (I)
 my father NEG accept me school
 'My father refused to send me to school.'
- (119) Maria mandurga prasa pa ba bindi si kamati na fera. (I)
 Mary rise-early city for go sell her tomatoe in market
 'Mary rose early to go to the city and sell her tomatoes at the market.'

The problem posed by these examples is that none of them can be interpreted unless something is 'mentally' supplied that is not overtly expressed: the cow doesn't dare *to come near* the fire; my father didn't accept me *going to* school; Mary got up early *to go to* the city.

I will contend that these examples manifest one and the same phenomenon, to be explicated as follows. Lexemes (LEX) may be construed as sets made up from a phonological form (PHON), a syntax (SYN) or subcategorization frame, and a meaning (SEM): $LEX_n = \{PHON_n, SYN_n, SEM_n\}$, where the integers give the address of the item within the lexicon. (Note they are not necessarily identical; thus, real synonyms, if such exist, would be lexemes bearing equal indices on SEM, but differing ones on PHON and possibly SYN.) Let us assume we can define an operation called INTERSECTION on two or more lexemes, so that, for example:

$$(120) LEX_i \cap LEX_j = \{PHON_{ij}, SYN_{ij}, SEM_{ij}\}$$

That is, the intersection of two lexemes-sets is a lexeme-set consisting of the phonological form and the syntax of one of the input items (not necessarily the same one),⁵⁰ and the meaning of either or both. Note that, all formalism apart, such a phenomenon is largely attested by thousands of examples of what has been variously called 'attraction', 'analogy', or 'contamination'. An elementary Kriyol example is *misturason* 'period (of women)', which combines the phonetics and semantics of (Portuguese) *menstruação* 'period', *mistura* 'to mix', and possibly *mis* 'month'.

Take now a possible instantiation of (120) with $LEX_i = \text{mandurga}$ 'to rise early' and $LEX_j = \text{bay}$ 'go'. This gives us a straightforward, fully lexical account of *Maria mandurga prasa* in (119). The syntactic structure of the expression is exactly as it appears to be, i.e.:

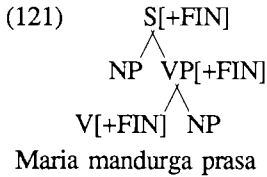

The mismatch between the syntax and semantics of **mandurga** as LEX_i , on the one hand, and the syntax and semantics observed in this construction, where the same lexeme appears to govern a locative complement (**prasa**), on the other hand, is the cue that leads us, as linguists and also, I assume, as speakers-hearers, to analyse **mandurga** as actually representing not one lexeme, but the intersection of two. The process can be graphically depicted with the following (pseudo) network:

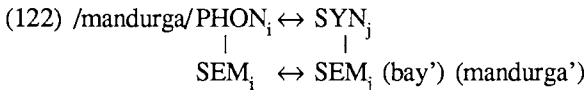

PHON_i is the access point from which the mismatch is taken stock of as symbolized by the double arrows and the vertical linkings. All in all, (122) should be viewed as one lexical matrix produced by the dynamic combination of two. A static rendering of this matrix might be as follows (see Pollard and Sag 1987):

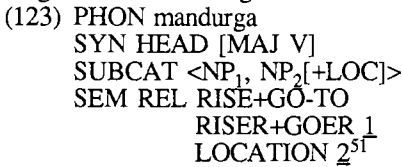

The question that must be raised, of course, is why can **mandurga prasa** only mean 'to rise early to go to the city', rather than, e.g., 'to destroy the city', supposing the subject to be not 'Mary' but, say, 'Gengis Khan'. At the same time, it is notheworthy that only locational nouns can follow **mandurga** as complements, so that we won't have, e.g., ***Maria mandurga si omi**, meaning 'Mary rose early to V her husband', with V denoting whatever a wife may do to her husband. Underspecification in the semantic network is, I think, the answer.

Indeed, consider that *go* in (122) is totally underspecified since its semantics is a matter of deduction, its phonological form is empty, and its syntax could characterize any transitive verb. Therefore, to retrieve the 'missing verb', one must rely entirely on the combinatory of the meanings of the overt verb and of the complement. The implication is that the inferred element will have to be the most prototypical one with respect to the semantics of the given elements, since they are all we have to work upon.

Now, the prototypical thing one may do in connexion with a place is go to it, be in it, pass through it, or come from it. Actually, those are the only things one may do, insofar as building, destroying, etc. a city, for instance, is not something one does to a place *qua* place, but to the object, the collection of houses, that happens to be in the place.⁵² Conversely, the selection of place nouns over all other types of nouns is explained. Indeed, place nouns are special in suggesting such prototypical actions with respect to them. In contrast, there are just too many things one can do to and with object nouns, including place nouns when interpreted metonymically, for deduction in an underspecified network to be feasible.

Still, we remain with a choice: why *go* rather than *be*, *pass* or *come*?⁵³ Knowledge of the world, also known as plain common sense, will give us the answer. What would ‘Mary rose early to be in the city’ mean? Not much if this is interpreted as it must given semantic intersection, namely that she is in the city when she gets up. That is to say, ‘rise-in-X-and-go-to-Y’ makes sense as a compound action, but ‘rise-in-X-and-be-in-X’ obviously does not, since it carries no information whatsoever. Another interpretation, viz. ‘rise-in-X-and-be-in-Y’, is simply nonsensical, implying ubiquity as it does. ‘Mary rose early to come from the city’ is absurd for the same reason — imagine a compound action ‘rise-in-X-and-come-to-X-from-Y’. Finally, *pass* would either induce the same effect as the nonsensical reading of *be*, or it would make sense simply by being a possible implicature of *go* — when you go to some place, nothing implies you will stay there. Therefore, given what one may sensibly do in terms of concomitant motions when getting up, *go* remains as the only possibility. And the overall interpretation of **mandurga prasa** appears thus as resulting from the composition of the prototypical interpretation of predicates involving locational arguments with a common sense understanding concerning possible compound activities.

Although I will not pursue this track here because it would take us much too far from the descriptive task at hand, let me suggest also that there is a very real sense in which the implicit or ‘inferred’ motion verbs function like hidden units within pseudo-neuronal networks (see Kihm 1993 for an elaboration of this idea). The lexical matrices presented here should therefore be viewed as shorthands for cognitively real networks, just like the schemata of Cognitive Grammar (see Langacker 1987).

The analysis just proposed for **mandurga** readily extends to the other examples. **Osa** ‘to dare’ in (117) normally subcategorizes for VPs (e.g. **i osa pidi l dinyeru** ‘He dared ask him for money’). **Fugu** ‘fire’ must be understood as **prasa** in (119), i.e. as an argument within a ‘hidden’ relation that is not expressed by the overt verb. This relation, in turn, is narrowly determined: (117) cannot mean that the cow doesn’t dare to play with the fire, or to put fire to something — as a

humanized animal well might — but only that she daren't confront the fire, be in its proximity. That is to say, *fugu* in (117) is construed as a place noun, viz. not (only) the fire in itself, but the place where fire is burning.⁵⁴ Likewise, *skola* in (118) is as much the place where children go and stay as it is the institution. Note how, as a consequence of the meanings of the verbs and their complements, the spatial relations in (117) and (118) are somewhat vaguer than they are in (119). Also note that in (118) the object of the overt verb is interpreted as the subject of the implied relation, giving rise to the following matrix:

- (124) PHON seta
 SYN HEAD [MAJ V]
 SUBCAT <NP₁, NP₂, NP₃[+LOC]>
 SEM REL ACCEPT+GO-TO
 ACCEPTER 1
 GOER 2
 LOCATION 3

Note here an interesting feature, viz. that the aspect value of the overt verb, which is perfective, does not match that of the implicit relation, which is obviously imperfective: what my father didn't accept is my going to school, not once, but repeatedly — my attending school, in other words. This is certainly linked to the fact that, although syntax presents us with one sentence <NP V NP NP>, semantics forces us to reconstruct two propositions, viz. *accept*(1) and *go*(2). There is thus a mismatch of the semantic and syntactic mappings, in the sense that the saturation of the structures by the arguments proceeds differently in both dimensions: there are two subject positions for the two arguments in the semantics, whereas in the syntax one argument occupies the only subject position, and the other has to go to the direct object position. This is illustrated in (125):

- (125) <x accept⁸⁰ y> SYN
 1 2
 / \
 (x ACCEPT+y GO) SEM

Being autonomous propositions, there is no reason that (x ACCEPT) and (y GO) should have the same Aspect value. On the other hand, the semantic value of the sentence is clearly a function of type A^B, i.e. a function from B to A, where A is the set of accepting individuals, and B the set of going individuals. The truth value of the sentence has thus to be computed on the set A x B, i.e. on the set (Cartesian product) of all couples made up of at least one accepter and at least one goer. This is another way of looking at the notion of compound proposition.

That said, the following example is challenging in that it seems to suggest an alternative solution that was not available with the preceding examples:

- (126) *Mininu misa si cakwal.* (HGRB)
 child piss his pants
 'The child wet his pants.'

Indeed, it seems we might achieve a fairly good account of the interpretation of this example by simply supplying in the syntax an 'abstract' preposition whose meaning would supposedly be 'in'.⁵⁵ Such a solution would be in the spirit of that proposed by Kayne (1984) for double object constructions in English. I am not ready to adopt it, though, for theoretical as well as for practical reasons. Theoretically, assuming such an entity as a phonetically empty preposition in the syntax clearly runs counter to every tenet of the theory here applied and, hopefully, developed. More seriously, *mininu misa si cakwal* does not mean that the child simply pissed in his pants; it means that he soaked them with piss. Of course, the typical situation is that he had them on. But that is a factual presupposition, not a meaning, and not a necessary one at that, since (126) is compatible with the, admittedly implausible, situation where the child pissed on his pants as they were lying on the floor.⁵⁶ No reasonable preposition can account for such a complex relational network. On the other hand, merely assuming that *misa* is transitive in (126) won't do, because how would we account, then, for the obvious difference between (126) and, e.g., *dwenti misa urina bermeju* 'The patient urinated red urine', where the verb is indeed transitive and affecting its object?

I will therefore have recourse to the same explanation as above, namely that the lexical matrices of the relevant verbs — or the relational networks they abbreviate — include hidden predicates, roughly representable as *moja* 'to wet' in (126), but as *fika* 'to stay' in (127):

- (127) *Kacu kustuma ja kasa.* (MM)
 bird accustom already house
 'The bird already accustomed itself to the house.'

In (128), on the other hand, two cases must be distinguished:

- (128) *Si bu ka misti bay sinema ku mi, enton bay bu kaminyu.* (I)
 if you NEG want go cinema with me then go your way
 'If you don't want to go to the cinema with me, then go your way!'

In *bay sinema* 'go to the cinema', the locational feature of the complement can be directly unified with the denotation of the verb, viz. motion. No further provisions have to be made, and of course *bay prasa* 'go to the city', etc. will be analysed in the same way, i.e. as below:

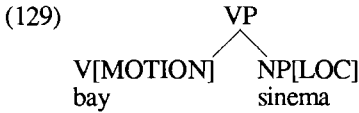

Tree (129) is licenced by the lexical ID rule (130):

(130) VP → H[49], NP (bay)

I give **bay** an arbitrary subcategorization index. Let us take it as characterizing motion verbs which admit of place nouns or names as direct objects. The feature [LOC] on the object thus becomes superfluous, since LOCATION is included in MOTION, and the SUBCAT feature on the verb (whose value is here 49) ensures that the features of the complement agree with those of the head.

Indeed, only prototypically locational complements can enter such constructions, so that, e.g., ***bay kil omi** is not a proper way of expressing 'go to that man'. A preposition must be used (**bay pa kil omi**, with **pa** 'for, in the direction of'). Possible complements are the following:

(131) N ten di janti Kancungu. (HGTD)
 I have of go-right-on Cantchungo
 'I have to go right on to Cantchungo.'

(132) E bay nunde rey. (I)
 they go where king
 'They went to the king's place.'

(133) N medi bay kil ladu. (HGTD)
 I fear go that side
 'I'm afraid of going that way.'

We have here a place name as in (131), a generic place denotation as in (133), and an interesting item in (132), viz. **nunde** which can be used as an interrogative or relative NP meaning 'where', or as a generic locational NP meaning 'place of' (cf. French *chez*).⁵⁷

Furthermore, there is the implication that the place involved is reached, not entered. This means that one will normally say, e.g., **Jon bay na kasa di Ze** 'John went to Joe's house' rather than ?**Jon bay kasa di Ze**. Similarly, [MOTION] appears to be quite a restricted feature, not coextensive with the general notion of movement from one place to another. Actually, it seems that only **say** 'go/come out', also 'be from' (**Ze ta say Giné** 'Joe is from Guinea'), **janti** 'go right on', and **ciga** 'arrive' behave like **bay**. The following examples are worth notice:

(134) Awos n fasi kwatru dia n ka ciga prasa. (HGMT)
 today I do four day I NEG arrive city
 'Today it's four days since I haven't gone downtown.'

(135) Ntori say dentru suma ferca. (MJMB)
 Ntori come-out inside like arrow
 'Ntori came out from inside like an arrow.'

- (136) Nin si fin di mundu ku bu bay n na bin bu tras. (HGRB)
 not-even if end of world that you go I A come your behind
 'Even if you go to the end of the world [lit. 'if it's to the end of the world that you go'], I will come after you.'

Example (135) in particular makes it very clear how the direction of the movement is entirely encoded within the verb. And example (136) shows that complements of this kind may be separated from their heads, here through clefting.

While we are on the subject, note that Kriyol patterns like Portuguese or French rather than like English when it comes to encoding the path and the manner of a movement. That is to say, 'John ran into the house' cannot be rendered literally as **Jon kuri na kasa**, which only means 'John ran in the house'. The correct translation is (137), with Path being first expressed through a verb and a selected preposition (**yentra na**), and then Manner, through another verb (**kuri**) in a separate clause (see Talmy 1985 for an insightful analysis of these phenomena):

- (137) Jon yentra na kasa i na kuri. (I)
 John enter in house he A run
 'John entered the house running.'

Compare Portuguese *João entrou na casa correndo*. (137) ought probably to be analysed as a paratactic construction.

Bay bu kaminyu 'go your way' at the end of (128), on the other hand, is different since **kaminyu** is obviously not the goal of the movement. To put it in syntactic terms, it is not the object of **bay** itself, but of **bay** plus some other item which is able to subcategorize for **kaminyu**. I will therefore analyse this construction as I did **mandurga prasa**, etc., that is as involving a hidden predicate, possibly with the semantics and the syntax of **sigi** 'follow' in this case. Another expression which probably deserves the same analysis is **bay byas**, literally 'go trip', i.e. 'go on a trip'.

Building on the idea of lexical intersection expounded above, I will therefore propose a schematic compounded lexical ID rule to account for all cases encountered so far:

- (138) VP \rightarrow H[i \cap j], NP

As we saw, the complement NP must indeed agree with the compounded subcategorization requirements of the head. Pairing (138) with **mandurga prasa**, for instance, would fix *i* at [1] and *j* at [49],⁵⁸ with **bay bu kaminyu**, we would get, say, [49] for *i* and [2] for *j*.

Finally, it must be emphasized that all these constructions are more or less idiosyncratic, being linked to particular verbal items and specific types of complements. One may **mandurga prasa**, **tabanka** ('village'), **fera** ('market') and

so forth, but one may not ***lanta prasa**, for example, even though **lanta** ‘to get up’ is quite close semantically to **mandurga**. With **bay bu kaminyu**, it seems we fully enter the realm of idioms, as we certainly do with the following examples which illustrate yet other kinds of apparently unaffected objects:

- (139) *Mininu fedi rabada.* (HGTD)
 child stink arse
 ‘The child’s arse stinks.’
- (140) *Ami n susu korson.* (MM)
 I[_{TOP}] I dirty heart
 ‘As for me, I have a black heart.’

Very little variation is authorized in (139) — inasmuch as other body parts may stink — and none at all in (140), the meaning of which (‘I’m nasty’) is of course not compositional.⁵⁹ Other similarly constructed expressions that may be imagined — such as, e.g., ***bajuda bonitu kara** /young-girl pretty face/ to say that ‘the young girl has a pretty face’ — are firmly rejected.

Syntactically, I propose to treat (139) and (140) as more instances of lexical compounding, that is, I will deal with their idiomaticity and that of the other examples in purely semantic terms, following traditional GPSG practice (see Gazdar et al. 1985:236-242). It is no so clear, however, exactly what lexical matrices should intersect those of **fedu** and **susu**. Perhaps **tene** ‘to have’ (see **mininu tene rabada ku na fedura** ‘the child has an arse that stinks/a stinking arse’); perhaps some relational preposition roughly meaning ‘about’ which incorporates into the verb or the predicative adjective. It does not really matter which, as long as we stick to a strictly lexical solution on the one hand, and let semantics do most of the job, on the other hand.

2.4.5. *Argument shifting verbs*

A number of Kriyol verbs exhibit a fair amount of flexibility as to what might be metaphorically called the directions of flux within the relational networks centred around them. A few examples will demonstrate.⁶⁰

- (141) *Karni ka sobra na kasa.* (I)
 meat NEG remain in house
 ‘There isn’t any meat left in the house.’
- (142) *N sobra restu pa ora ku n riba.* (HGTC)
 I leave rest for time that I return
 ‘I’ve left the rest for my return.’
- (143) *Omi suta si ispada na pilon.* (HGTC)
 man strike his sword on mortar
 ‘The man struck the mortar with his sword.’

- (144) Nya mama tudu na say liti. (HGTC)
 my breast all A go-out milk
 'Milk is constantly oozing out of my breasts.'

Similar cases could be multiplied. In (141) and (142), we see one lexical item, *sobra*, enter quite different relational networks that call for distinct words in English and Portuguese ('remain' or *sobrar* vs. 'leave' or *deixar*). True, 'leave' is easily analysed as the causative counterpart of 'remain' ('let remain'). As we shall see, however, there is a causative derivation in Kriyol, and it is not used here. Other verbs that make do for quite distinct relationships are, e.g., *pista* which translates as either 'lend' (P. *emprestar*) or 'borrow' (P. *pedir empréstimo*), and *renda* which betrays the same ambiguity as (American) English 'rent' or Portuguese *arrendar*.

What is interesting about the next two examples, on the other hand, is that the relations between the arguments and the verb could all be expressed differently, without the informational content of the sentence being modified. For example, for (143) one could just as well say *omi suta pilon ku si ispada* (see gloss); for (144), *liti tudu na say (di) nya mama* (see gloss). It would seem, therefore, we are dealing with a different phenomenon from the well-known transitivity alternations that will come under scrutiny later on. On the other hand, the semantic stability across modifications is an important point. Indeed, the alternative English formulation, 'The man struck his sword on the mortar', does not mean the same as the gloss of (143), as it does not imply that the mortar was split asunder (or at least affected) as a result, as it undoubtedly was judging by the accompanying cartoon in the original comic-book.

I would like to suggest that this rather extended possibility the language has of shifting around arguments is a reflection of the widespread availability of subcategorization-changing verbal morphologies in the surrounding languages, especially those belonging to the Atlantic family. For example, there is in Manjaku a verbal suffix *-na* which allows the argument bearing the semantic role Instrument to be constructed as a direct object of the verb (e.g. *rena katam* /eat+INSTR spoon/ 'to eat with a spoon' — see Buis 1990:47). Likewise, one finds a suffix *-ës* whose meaning is roughly 'separation from the speaker or object of reference' (e.g. *fal* 'cut', *falës* 'cut off'). The implication is that in, e.g., *suta si spada, si spada* is not in fact the direct object of *suta*, but an oblique instrumental object promoted to the position of first complement. In Manjaku, this promotion is indicated by the morpheme *-na*, so that *rena* is assigned the following lexical entry (see Pollard & Sag 1987 for the formalism).⁶¹

- (145) PHON rena (Manjaku)
 SYN | LOC HEAD [MAJ V]
 SUBCAT NP₁ NP₂
 SEM | CONT REL STRIKE
 N₂ STRIKER
 N₁ INSTRUMENT

In Kriyol, in contrast, there is no overt marking in such cases. We are thus led to posit a multiple-choice lexical entry:

- (146) PHON suta
 SYN | LOC HEAD [MAJ V]
 SUBCAT α NP₁ NP₂
 SUBCAT β PP₁ NP₂ NP₃
 SEM | CONT α REL STRIKE
 NP₂ STRIKER
 NP₁ STRUCK
 CONT β REL STRIKE
 NP₃ STRIKER
 NP₂ INSTRUMENT
 PP₁ STRUCK

Which choice of SUBCAT frame and associated content is realized and read off the phonological form will depend entirely from the syntactic context and the ordinary reliance on cognitive routines. For example, hearing (143), one will automatically assume that *si spada* cannot be what is struck and must be the instrument the man strikes with — in whatever direction the deduction runs, if it is a deduction. In turn, it is the existence of the branching lexical entry which makes the conversion possible, ensuring that the overall relational network is preserved, no matter whether what is struck is encoded as a direct object and the instrument as an adjunct PP, or the instrument as a direct object and what is struck as a selected PP.⁶² In English, where the lexical entry for ‘strike’ presumably does not include the CONT β part, the literal rendering of (143) can only receive the less usual interpretation where the sword is the thing struck, and the mortar the (passive) instrument.

If this analysis holds water, then, we would have here a case of ‘silent’ interference. In any event, it is a fact that such argument shiftings are not expected in a language with so little derivational morphology as Kriyol is. Nevertheless we see it behaving just like a morphologically rich language such as Manjaku. Since Kriyol has less lexical entries than Manjaku — only *suta* vs. both *bup* and *bupna* for ‘strike’ and ‘strike with’ — then it must have more complex ones.

2.4.6. Subcategorized PPs

A number of Kriyol verbs subcategorize for complements embedded under prepositions. We already met a few, viz. the modal verbs **dibi di** ‘must’, **ten di** ‘have to’, **ciga di** ‘already V’, **kaba di** ‘finally V’, **tenta di** ‘try’. Here, there might be some debate about whether **di** should be considered a preposition or a complementizer — assuming there to be a substantial difference between both entities. The issue is clearer, however, with verbs such as **yentra (i yentra na kasa)**, ‘S/he went into the house’, not ***i yentra kasa**); **sinta (i sinta na kadera)**, ‘S/he sat (down) on the chair’, not ***i sinta kadera**); **lanta (i lanta di kama)**, ‘S/he got up from the bed’, not ***i lanta kama**); **puy (i puy libru na mesa)** ‘S/he put the book on the table’, not ***i puy libru**); **miti (i miti karni na želeyra)** ‘S/he put the meat in the fridge’, not ***i miti karni**); **gosta (i ta gosta di sukar)**, ‘S/he likes sugar’, not ***i ta gusta sukar**); **fiya (n ka ta fiya na elis)**, ‘I don’t trust them’, not ***n ka ta fiya elis**). The preceding list is probably not exhaustive, although not by far. Of course, these subcategorization peculiarities will be part of the lexical definitions of the particular items. For example, **gosta** could be introduced by the following lexical ID rule:

(147) VP → H[n], PP[PFORM *dī*] (*gosta*)

2.5. Adjoined PPs

As their name tells, adjoined PPs are prepositional phrases bearing diverse roles, whose presence is not obligatory within the relational network centred around a given verb. For instance, **ku si spada** ‘with his sword’ in the ‘simpler’ version of (143), **omi suta pilon ku si spada** ‘The man struck the mortar with his sword’, is this kind of grammatical bird, insofar as **omi suta pilon** ‘The man struck the mortar’ is a perfectly self-supporting sentence.

Quite at the beginning of this chapter, it was mentioned that the linear ordering of adjoined PPs vis-à-vis the rest of the sentence exhibits some degree of freeness. I won’t come back to this point here. What I intend to do is take opportunity of this section to make an inventory of Kriyol prepositions, with special emphasis on the semantic roles played by their projections.

Formally, Kriyol prepositions are simple or complex. Simple prepositions include **di** ‘of, from’, **kontra** ‘against’, **ku** ‘with’, **na** ‘in, on, at, to’, **pa** ‘for, by, toward’, **sin** ‘without’, **suma** ‘as’, and **te** ‘until’. Complex prepositions include **banda di** ‘about, close to’, **ba(s) di** ‘under, below’, **dentru di** ‘inside’, **diyanti di** ‘before, in front of’, **dipus di** ‘after’, **disna di** ‘since’, **filadu di** ‘in front of, across’,

fora di 'outside, out of', **juntu di** 'near', **lungu di** 'along', **lunju di** 'far from', **riba di** 'on, above', **tras di** 'behind'. As it appears, all complex prepositions are made up of **di** preceded by an element which may be an adjective (**lunju** 'far', **juntu** 'close, similar'), an adverb (**bas** as in **i sta la bas** 'S/he's over there below', **dentru** 'inside', **disna** 'long ago', **filadu** 'in front', **fora** 'outside', **lungu** 'alongside', **riba** 'above'), or a noun (**banda** 'edge', **diyanti**, **tras**). There is little to say about such categorizations, except that the last two items are shown to be nouns by the fact that, with personal pronouns, we do not find, e.g., ***diyanti di mi** 'in front of me' or ***tras di mi** 'behind me', but **nya diyanti** and **nya tras**, i.e. literally 'my front' and 'my behind' (no pun possible!). I will adopt an analysis according to which **di** is the head and the accompanying item is in Spec position:

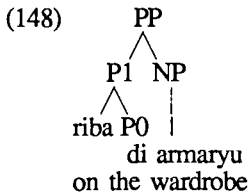

To account for **nya/bu/si/no/bo/se diyanti/tras** 'before/behind me/you/him/her/it/us/them', which obviously cannot be construed as a PP, but has to be an NP, we are forced to assume that the feature <ADV, +> can be assigned to an NP in Kriyol, so that **i sta nya tras** 'S/he is behind me' is associated with the following tree:⁶³

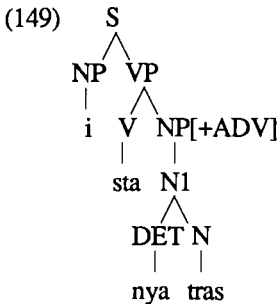

In so doing, it is not necessary that we renounce the FSD posited in Gazdar et al. (1985) according to which phrases are normally unspecified for adverbialness, and which seems to hold good for Kriyol as well. Indeed, **nya**, etc. **diyanti/tras** are clearly fixed phrases, which means they must be specifically mentioned in the lexical entries for **diyanti** and **tras**, and this is where the [ADV] feature is to be assigned them.⁶⁴ There is a temporal use of **tras** meaning 'ago', as in **tras di tris mis** 'three months ago'.⁶⁵

Finally, one finds more complex PPs such as **pa bya di**, lit. 'by way of', i.e. 'because of', **na metadi di** 'in the middle of',⁶⁶ and **na banda di** with the same meaning as **banda di**. Their representation is straightforward:

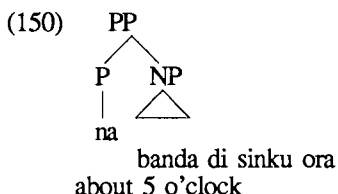

Na, from Portuguese *na* 'in the (feminine)', appears as the locative preposition *par excellence*, encoding as it does the spatial relations BE-INSIDE (*i sta na kwartu* 'S/he's in the room'), BE-ON-THE-SURFACE (*i sta na mesa* 'It's on the table'), BE-AT-A-LOCATION (*i sta na fera* 'S/he's at the market'). Concerning the first of these relations, **na** has a broader meaning than **dentru di** as it is not limited to clear-cut containers or locales. For instance, one may say **dentru di kwartu** or **dentru di kasoti** 'inside the box' as well as **na kwartu** or **na kasoti**.⁶⁷ But ?*i na dita dentru di kama* 'S/he's lying inside the bed' is not a proper alternative to *i na dita na kama* 'S/he's lying in bed'. Also note this example:

- (151) Bin bunba n dabi na kama. (HGBD)
 come pump me bedbug in bed
 'Come and spray the bugs in my bed!'

The conflation of the 'in' and 'on' meanings within **na** should not be considered a 'simplification' due to creolization. Indeed, it is found in Portuguese as well: *está na mesa* 'It's on the table', *está no chão* 'It's on the ground', etc. On the other hand, **na** 'on' and **riba di** do not contrast entirely in terms of contact or absence of contact with some surface as English 'on' and 'above' do (see Hawkins 1988). Clearly, one must say, e.g., **avyon na pasa riba di prasa** 'The plane is passing above the city', not ***avyon na pasa na prasa** (unless it's taxiing through it). But **riba di** is also appropriate to describe the situation where something is on some high surface — i.e. higher than an average-sized human (see (148)).⁶⁸ **Na** is also the preposition used in order to express any vague spatial relation implying contact and no movement, as in this example:

- (152) Omi sinti kusa ngata l na garganti. (MCOMM)
 man feel thing attach him at neck
 'The man felt that something was attached at his neck.'

Finally, **na** is used marginally whenever there is need to fill the gap left by the absence of a preposition specifically encoding the addressee or beneficiary role

(Portuguese *a*). For instance, suppose we want to say, ‘They turned me over to the policeman’ (P. *entregaram-me ao polícia*). We cannot say **e nterga n pulisya**, since this means the contrary, viz. ‘They turned the policeman over to me’. Unfortunately, as we shall see in Chapter 4, there is no non clitic accusative form of **n** ‘I’.⁶⁹ The only way out of the difficulty is then to construct the sentence as it would be in Portuguese, using **na**, viz. **e nterga n na pulisya**. (I am not claiming that such constructions are actually calques from Portuguese, although they might be, judging by the uneasiness of purist informants with these sentences.)

Pa is another semantically rich element. Its uses as a complementizer will be examined at length in Chapter 5. As a preposition, it has several domains of use. In one, its basic meaning is directional, be it spatial directionality (**mininus na bay pa skola** ‘The children are on their way to school’, **leba arus pa kasa** ‘Take the rice home’), or relational directionality (**n fasi l pa bo** ‘I did it for you’).⁷⁰ In this capacity, **pa** represents the reflex of Portuguese *para*.⁷¹ But it also inherits some of the meanings of Portuguese *por* which left no other trace in Kriyol. We thus find **n pasa pa Bisaw** ‘I passed through Bissau’ (P. *passsei por Bissau*), **i yentra pa janela** ‘S/he came in through the window’ (P. *entrou pela janela*), **dus byas pa simana** ‘twice a week’ (P. *duas vezes por semana*). The distributive meaning recurs in expressions like **kada kin pa si manera** ‘Everybody after his own fashion’. And, as already mentioned, **pa** is used to mark the agent of passive verbs, a rare and un-Kriyol construction:

- (153) Kil asasinus yera ba komendadu pa un branku. (RB)
 that murderers be+PAST PAST commanded by a white
 ‘Those murderers were commanded by a white man.’

Abstracting from its possible uses as a complementizer, **di**’s main functions are (i) as a directional preposition implying movement towards some setting which represents the dominating viewpoint of the moment (**i bin di Bisaw awonti** ‘S/he came from Bissau yesterday’, **n na bin di Bisaw amanyan** ‘I’ll come from Bissau tomorrow’); (ii) as the marker of a relation between two (sets of) entities, whatever the precise roles of the said (sets of) entities vis-à-vis one another. The latter function is by far the broadest and the vaguest, as it standardly covers possession (**libru di Ze** ‘Joe’s book’), responsibility for existence (**libru di Ze** ‘Joe’s book [that he wrote]’), cognitive connexion (**monumentu di Pijigiti** ‘the monument of Pijigiti’),⁷² affectedness (**distruson di prasa** ‘the city’s destruction’), and probably more. A limited temporal use of **di** is also to be mentioned, in fixed expressions like **di parmnyan** ‘in the morning’, **di tardi** ‘in the evening’, and **di noti** ‘at night’ (cf. Portuguese *de manhã*, *de tarde*, etc.).

There is little to say about **ku** 'with' and **sin** 'without', except that the former is also a conjunctive 'and' (see Chapter 4), and the latter can also function as a complementizer (see Chapter 5).

Finally, I give a few examples which illustrate the uses of **disna di**, **te**, **suma**, and **kontra** as prepositions — as adverbs or complementizers we will meet them again in the next section and in Chapter 5.⁷³

- (154) Sapu Fora sinta na nyeme kola disna di novi oras di
 Sapu Fora sit A munch cola-nut since of 9 hours of
 parmanyant te sinku oras di tardi. (FJDM)
 morning until 5 hours of evening
 'Sapu Fora sat munching cola-nuts from 9 o'clock in the morning
 until 5 o'clock in the evening.'
- (155) Bu yabri boka suma baley furadu. (HGTD)
 you open mouth as basket holed
 'You opened your mouth like a basket with a hole in it.'
- (156) I jiru suma si ermon. (DR)
 s/he clever as his/her brother
 'S/he's as clever as his/her brother.'
- (157) N na fasi operason kontra dabi. (HGBD)
 I A make operation against bedbug
 'I'm making an anti-bug operation.'

A few general remarks about prepositional phrases in Kriyol. First, it is rather remarkable how much Kriyol remained (or became) close to Portuguese in this area and showed little tendency to align itself with the surrounding Atlantic languages.⁷⁴ Possessive constructions involving nouns are probably the clearest example of this proximity. To take only two standards of comparison, Manjaku and Dyola, we see complements of nouns being directly postposed to their heads in the former (e.g. *kato nasien* /house chief/ 'The chief's house — Buis 1990:55), a construction which happens to be widespread in a number of creole languages (e.g. Haitian *kay chef la* 'id.' — see Lumsden 1989). Dyola, for its part, resorts to the 'John his hat' strategy (e.g. *alasan esyko* /Alasan village+Person Marker/ 'Alasan's village' — Sapir 1969:27), which is not unknown among creole languages either, as shown by Aku (Gambian Creole English) *pikin im dadi* /child his father/ 'The child's father' — see Abourizk 1991). Kriyol, in contrast, did not diverge in the least from its lexifier language in this area.

It is true, also, that Kriyol shares a number of typological features with Atlantic languages, e.g. in their all having prepositions rather than postpositions or other means for marking adjuncts. It may not be pure chance, indeed it is most certainly indicative of a good degree of interference and conflation, that Manjaku has a preposition *di* meaning 'in, on' (also in Dyola) which is used to construct complex prepositions semantically parallel to their Kriyol equivalents (e.g. *di ujara* /in cause/ 'because of', *di utsand* /in exterior/ 'outside', etc. — see Buis 1990:34).

This overall similarity may be responsible for apparent conservatism of Kriyol vis-à-vis Portuguese: after all, there were few occasions of conflict between the different grammars internalized by the first creole-speakers (in this area).

As a measure of the real, albeit not always readily perceptible, distance of Kriyol to its lexifier language, one should not forget the fact that Kriyol often eschews the use of prepositional phrases thanks to its modal verbs. For example, **i jumna n i bay**, literally ‘He anteceded me he left’, is certainly more idiomatic, ‘better’ Kriyol than **i bay antis di mi** ‘He left before me’ (P. *foi-se antes de mim*). Likewise, **i tarda n ka oja u**, literally ‘it lasted I haven’t seen you’ is to be preferred by far to the slavish imitation of Portuguese (or English, or French) **n ka oja u dedi manga di tenpu** (P. *eu não te vi desde muito tempo*).

To conclude on a syntactic observation, there seems to be an almost complete overlapping of the notion ‘adjunct’ and the category PP in Kriyol. To put it differently, all phrasal adjuncts are PPs, and almost all PPs are adjuncts, to the exception of a few PP-selecting verbs and marginal constructions like **e nterga n na polisya** (see above). We may therefore set up a hierarchy $1 < 2 < \text{OBL}$, where 1 is the Accusative object of monotransitive verbs or the Dative object (Goal) of ditransitive ones, and 2 is the Accusative object (Theme) of ditransitive verbs. And the overlapping of adjuncts and PPs will be expressed by the following default biconditional:

$$(158) \text{FSD: } \text{XP}[\text{OBL}] \Leftrightarrow (X = \text{P})$$

That is, the category of a (maximally) oblique XP is PP by default.

2.6. Adverbs

This category is notoriously some sort of a holdall where all kinds of stray elements can be bundled together. Nevertheless, I will try to be orderly, and I will distinguish — with little originality — two types of adverbs: (i) local adverbs; (ii) sentential adverbs. Among the former, I will give particular attention to the exotic species known as ‘ideophones’.

2.6.1. Local adverbs (including ideophones)

I take all adverbs to be of type $\langle \text{VP}, \text{VP} \rangle$, i.e. elements which map a VP onto a VP (see Gazdar et al. 1985:193; also Dowty et al. 1981:232ff.). Local adverbs are then those adverbs such as VP is VP[-SUBJ], and which have scope only over the domain dominated by VP[-SUBJ], i.e. the predicate. This excludes, arbitrarily perhaps, but I think sensibly, all NP modifiers with meanings like ‘very’, ‘almost’,

and so forth, i.e. <NP, NP> type elements. Such items will be studied in chapter 4. Of course, predicates include adjectival and noun predicates, with the effect of making the exclusion just mentioned sometimes not as perspicuous as we would like it to be.

Local adverbs then modify the predicates over which they have scope by modulating the degree or specifying the manner of the processes or states of affairs denoted by these predicates. They have no bearing on the truth value of the sentence as a whole, i.e. on the application of the particular predicate they modify to a particular subject. In this respect, 'ordinary' adverbs and ideophones are identical, and it is mainly as a matter of convenience that I will separate them, first cursorily characterizing the former, then reviewing the latter as exhaustively as possible. Here is a representative sample of ordinary Kriyol adverbs:

- (159) Bu ka jubi ba nan diritu. (I)
 you NEG look PAST indeed well
 'Actually you hadn't looked well.'
- (160) I na kume l propi. (I)
 s/he A eat it really
 'He's really going to eat it.'
- (161) No ta brinka ba sabi. (I)
 we A play PAST nicely
 'We used to play nicely.'
- (162) Bu ta kanta bonitu. (I)
 you A sing well
 'You sing well.'
- (163) N kontenti del dimas. (I)
 I satisfied-of+it much
 'I'm quite satisfied with it.'
- (164) No pranta amonton. (MC)
 we plant vainly
 'We planted in vain.'
- (165) Kin ku si mon seku purmeru, el ku na fika na kasa.
 who that his/her hand dry first s/he[^{TOP}] that A stay in house
 'The first one with a dry hand is the one who'll stay at home.'(MM)
- (166) I ka ta permiti n ba pa n papy koretamenti. (I)
 it NEG A permit me PAST for I speak correctly
 'It didn't permit me to speak correctly.'
- (167) Ami n gosta ciw di muzika. (I)
 I[^{TOP}] I like a-lot of music
 'Me, I like music a lot.'
- (168) I ka tan ciw asin. (I)
 it NEG too a-lot so
 'It isn't that much either.'

As can be seen, there need not be any formal difference between adjectives and adverbs (see *sabi*, *diritu*, etc.). In fact, items like *koretamenti* are blatant borrowings from Portuguese. Sometimes, however, the adjectival and adverbial uses of the same item differ semantically. For example, *amonton* (164) as an adjective means 'lazy', 'careless'. *Ciw* 'a lot' (from P. *cheio* 'full') is a bit special insofar as it can serve either as an adverb (167) or as a predicative adjective (168), never as an attributive adjective.

Naturally, there are also 'specialized' adverbs, so to speak: *tan* 'too' (a reduced form for *tanbi* — P. *tambem*), *ja* 'already', *janan* 'at-once', *son* 'only', *gosi* 'now':

- (169) N manda ba ja fasi l. (I)
I order PAST already do it
'I had already had it done.'
- (170) Ora ku e mara l ja na po kil si amigu bin
time that they tie him/her already on tree that his/her friend and-
fala pa e larga l. (MM)
then say for they free him/her
'Once they had tied him to a tree, that friend of his then said they
should let him go.'
- (171) Parsi n kuma no ka ten ja mafe. (HGCS)
seem me KUMA we NEG have already mafe
'It seems to me we haven't got any mafe left.'
- (172) Es kusa li i pa kumsa janan desdi gosi. (FJGK)
this thing here it for begin at-once since now
'This thing should be got into right now.'
- (173) N ka sopra ja kwas ku nada. (I)
I NEG remain already almost with nothing
'I was almost left with nothing.'
- (174) N sibi son kuma nya pirkitu karu. (I)
I know only KUMA my parrot expensive
'All I know is that my parrot is expensive.'
- (175) Kaw kaba na sukuru son e bay. (I)
place finish A dark only they go
'As soon as it was dark they left.'
- (176) I cora te. (I)
s/he cry until
'She cried a long time.'

Many more items could be added to the list, e.g. *senpri* 'always', *nunka* 'never', *awos* 'today', *awonti* 'yesterday', *amanyan* 'tomorrow', *inda* 'again', and so forth. It would take too much space to review them in detail here, especially since many of them will be taken up again in the next chapters. Before making a few remarks about the examples above, however, I cannot do less but to mention

the locative adverbs **li** 'here' and **la** 'there', which form indeed a simple system, whereby **li** denotes the area in the vicinity of the speaker, and **la** all the rest.

In (169), **ja** (P. *já*) has its full meaning of 'already', whereas in (170) it looks more like some sort of sequencing flag in connexion with **bin**. The distinction between both varieties is often fuzzy, which won't surprise us since we stick to the principle that all morphemes have meaning and there is no such thing as a 'pure marker'. In (171), the combination of **ja** with the negation to express 'not ... any longer' may be considered a Portuguese interference (compare *já não temos mafé*) in view of the availability of 'deeper' variants (e.g., **no ka torna tene mafe** — see above). I translated **janan** — apparently composed of **ja** 'already' and **nan** 'indeed' (see below) — as 'at once', although its semantics is more subtle, since it really means 'from now on, right away'. The implication in (172) is thus that the thing begun will be continued.⁷⁵ As such, **janan** appears as the adverbial counterpart of the complex temporal expression **ba ta** (see chapter 3). The construction exemplified in (175) is also interesting because it constitutes the creolization of a Portuguese construction using *apenas*, a now rather literary synonym of *somente* 'only', the probable etymon of **son** (see Schuchardt 1888) — compare P. *apenas escureceu, foram-se embora*. Finally, **te** in (176) must be pronounced with a protracted vowel and a very high tone in order to make sense in this context — otherwise, it means 'until' or 'and' (see chapters 5 and 8).

This rapid browsing among Kriyol adverbs makes inescapable the conclusion that adverbs are not in any sense a unified category. In fact, they are not a category at all. What we have are nouns, adjectives, possibly phrases and sentences, all bearing an [ADV] feature. For reasons that will become clearer in chapter 4, I consider the 'specialized' adverbs like **senpri**, etc., including the locative adverbs to be nouns or NPs.

The examples above all show the favoured or, better, neutral position for these adverbials, as they would be better called, viz. right after the predicate head they modify. Since they are adjuncts, however, other positions are of course possible, in particular at the beginning of the sentence. Some emphasis always results, though, so there is reason to believe that initial adverbials are in fact topicalized elements. Moreover, topicalization seems to be limited to NP-type adverbials, as against adjectival adverbials. For instance, **amanyan n na bay** 'Tomorrow I'll leave' or **senpri e ta fasi kila** 'Always they do that' sound much more natural than, e.g., **?bonitu bu ta kanta** 'Well you sing'. This might indicate that adjectival adverbials really modify the verb itself, as an adjective modifies a noun, while NP adverbials modify the VP. The distinction is shown graphically in (177) and (178):

- (177) bu kanta kil kantiga bonitu ‘You sung this song well’
 ((kanta bonitu)(kil kantiga))(bu)
- (178) n bay Bisaw awonti ‘I went to Bissau yesterday’
 (((bay)(Bisaw))(awonti))(n)

The absence of subcategorization for **bonitu** and **awonti** in either case accounts for neutral linear order and for the fact that **bonitu** is not entirely prohibited from occurring in initial position nonetheless, provided it receives strong focal stress.

Ideophones (also called ‘phonaesthetic adverbs’ — see Rowlands 1959), in contrast, do not even show such limited ‘mobility’. They must follow the head of the predicate they modify, either immediately or after an indefinite number of complements. Furthermore — that is their best-known and defining character — each ideophone ‘goes with’ one head, be it a verb or an adjective. Semantically, they modify the intensity or the manner of the process or state of affairs, as the examples will clarify.⁷⁶ Of course, ideophones have no lexical equivalents in Portuguese and can only have been borrowed from surrounding languages, although which ones precisely remains a matter for further inquiry — one with little chance of success, as far as I can tell. The CVC pattern of many Kriyol ideophones betrays their borrowed character, in any event.

I will first list the intensifying ideophones, without trying to provide idiomatic renderings for each. Then I will give the modulating ideophones, including under this heading those which mean that the process is pursued to its end.

(a) Intensifying ideophones

badaw (forti badaw ‘very strong’), cep (dos cep ‘very sweet’), cut (mela cut ‘very sweet’), fandan (branku fandan ‘very white’), nok (pretu nok ‘very black’), potok/pucuk (susu potok/pucuk ‘very dirty’), wit (kintu wit ‘very hot’), yem (friyu yem ‘very cold’)

(b) Modulating ideophones⁷⁷

bik (kamalyon kume moska bik ‘The chameleon gulped down the fly: O = small thing’); buk (iransegu kume karnel buk ‘The python gulped down the sheep: O = big thing’); cabadan/caraw (burmeju cabadan/caraw ‘pink’); caw (burmeju caw ‘yellow’), cif (jugude ciga cif ‘The vulture landed smoothly’); cunblut (i kay na yagu cunblut ‘S/he fell in the water with a big splash’); fap (mininu kume arus fap ‘The child ate up the grains of rice: O = food made up of small parts in scattered state’); fas (yanda fas ‘Hurry up!’); fat (i yentra fat ‘S/he entered all of a sudden’); fep (i kume l fep ‘S/he ate it up’, paja kema fep ‘The grass burnt up’, i susa panu fep ‘S/he dirtied the cloth completely’, rey pasa elis konbersa fep ‘The king reported them the whole conversation’)

(MM)); fit (i pasa elis fit 'S/he rushed past them'); fuf (i mas el fuf 'S/he's definitely taller than him/her'); fup (baka say fup 'The cow rushed out: S = big thing'); fut (ratu say fut 'The mouse rushed out: S = small thing'); kan (seku kan 'completely dry'); kenkeren (san kenkeren 'quite healthy (again)'); kondon (garafa linpu kondon 'The bottle is totally empty': linpu 'clean'); kun (pidi inci l bariga kun 'A fart filled up his bowels'); kunkurun (n farta kunkurun 'I'm full up': farta 'be satiated'); pus (panu linpu pus 'The cloth is completely clean'); tep (n inci tep 'I'm full up'); tuc (i kay tuc 'S/he fell down with a thud'); wak (burmeju wak 'crimson'); yem (kaw kala yem 'The place became totally quiet').

Modulating ideophones may thus modify the meaning of the lexical head they go with. For instance, **burmeju** (P. *vermelho*) which by itself means 'red', gets specified to 'pink', or 'crimson', or 'yellow' (including 'orange') according to the appended ideophone. When this is the case, total completion appears as an associated implication, semantics permitting — i.e. not with colour adjectives, but definitely with **linpu** ('clean' or 'empty'). Another interesting observation is that ideophones have the effect of selecting not only objects (**kume bik/buk/fap**), but also subjects (**say fup/fut**) in terms of size. This may be an argument to support the assumption that subjects are subcategorized for as well as objects. It harks back, too, to Talmy's observation (1988) that absolute size does not belong to the notions that are grammatically encoded. Insofar as ideophones are in fact lexical items, members of a potentially (if not actually) open list, Talmy's generalization is not endangered by the present facts.

As already mentioned, ideophones of either sort are VP final, which sets them apart from other adverbs whose positional latitude is greater. This difference must be accounted for somehow. First, I will propose the following rule which is actually a rule schema over all lexical ID rules:

(179) VP → H[n, -AUX], [+ADV], W

This rule says that a VP headed by a non-auxiliary may comprise an adverb and something else. As it stands, it does not lead us to expect the difference just mentioned between ideophones and other adverbs, nor does it represent the fact that the former, contrary to the latter, are systematically paired with specific heads in a one-to-one relationship.⁷⁸ To remedy these deficiencies, I will assume that what basically differentiates both kinds of items is that ordinary adverbs are, as already noted, lexical or phrasal categories with a [ADV] feature, i.e. XP[+ADV], whereas ideophones are merely [ADV], i.e. a minor category like English post-verbal particles — with which they share many syntactic and semantic similarities. Given this, (179) rewrites as:

(180) VP → H[n, -AUX], XP[+ADV], W

No special LP statement evokes this rule. For ideophones, however, we have this other rule:

(181) VP → H[i, -AUX], PCL[ADV, i], W

I use PCL (particle) to refer to a lexical item which falls outside the X-bar system (see Gazdar et al. 1985:25). And I further assume that the lexical entry for any given ideophone includes the index of the head(s) it goes with. What we now need is an LP statement referring to this rule, viz.

(182) W < PCL[ADV, n]

This states quite simply that everything in the VP precedes ideophones. Since LP statements are local, adjuncts are not concerned by (182), so they can follow or precede ideophones. But, if they precede, they must come before the head of the VP since, as already mentioned, unordered elements do not intervene inside ordered sequences.

To conclude on ideophones, I must mention a special class of them which mimic noises or evoke corporal attitudes. If the former, they often go with **kudi** 'go NOISE' (also 'answer a call'). Examples are **kudi din** 'clang', **kudi wap** 'clash',⁷⁹ **yanda kinkirin** 'trudge along', etc.

2.6.2. Sentential adverbs

It seems rather natural to conclude this chapter on the simple sentence with items whose semantic scope bears on whole propositions. Their effect is to modulate, not the informative content of the proposition, but rather the way it is presented relative to the presuppositions of the speaker or the expectations of the hearer. To put it differently, sentential adverbs bear on the speech act embodied in the proposition rather than on the proposition itself. The following examples illustrate:

(183) N konta u ba kuma nya pirkitu karu de. (I)

I tell you PAST KUMA my parrot expensive DE
'I had told you though that my parrot was expensive.'

(184) Tisi n de un son pa li. (FJGK)

bring me DE one only by here
'Come on, bring me one over here!'

(185) Didu me es dus jintis bin nan pa mi sin nada n ka

DIDU ME this two persons come NAN for me without nothing I NEG
fasielis! Dews ka ta seta. (MSLK)

do them God NEG A accept
'And those two blokes would have come for me without me doing
anything to them! God forbid!'

- (186) Anta anyu gosi i tuga. (HGCS)
 ANTA you[POLITE] now it white-man
 'Are you now a white man, by any chance?'
- (187) Anta es rapas sta bon di kabesa me. (FJGK)
 ANTA this boy be good of head ME
 'So, is this boy really OK in his head?'
- (188) Asin me ku fulas bin konsigi ciga Kansala. (MK)
 so ME that Fulas BIN succeed reach Kansala
 'So, that's how the Fulas finally succeeded in reaching Kansala.'
- (189) N kuda i lanta, didu me i na durmi. (BPB)
 I think s/he get-up, DIDU ME s/he A sleep
 'I thought he was up, actually he's still asleep.'

I made no attempt at providing literal glosses for the sentential adverbs exemplified here, insofar as knowing what they mean, more than with any other lexical items, is to know how to use them. **De** could be dubbed an 'assertion enhancer', since its effect is to emphasize the fact that an assertion has been made by the speaker, and that some effect is expected thereupon. Hence the contrastive effect, rendered by 'though', in (183) where it is known that the addressee did not act in conformity with the speaker's reiterated assertion. In imperative contexts like (184), what is enhanced is the speech act 'ordering', with a pressing command as a result. Clearly, **de** must have been borrowed from neighbouring languages. Indeed, it is found in Mandinka (Rowlands 1959:136), and also in several, if not all, Atlantic languages. Note that it has a 'lighter' variant, viz. **pa**, from P. *pa*.

Nan is also an assertion enhancer — Pinto Bull (1989) translates it as 'indeed' (*pois, en effet*). It differs from **de**, however, in conveying an oppositive shade of meaning which is only contextual in **de**. Propositions with **nan**, as in (185), always seem to counter a previous utterance or thought claiming or suggesting the opposite of what they assert.⁸⁰

In contrast with **de** or **nan**, **anta** (probably from P. *então* 'then', dialectal and/or archaic *antão*) may be called a 'question enhancer'. The typical effect of so emphasizing that a question is being asked is to convey incredulity on the part of the asker. As a matter of fact, **anta** is regularly used with questions which plainly contradict what the scene gives all to see, as in (186) and (187).

In (187), **anta** cooccurs with **me**. 'Summarizer' is probably as good a name as any for this item. It emphasizes the fact that various discursive moves (not necessarily verbalized) have been made and now some conclusive speech act has to be performed. In (188), the speech act is an assertion, whereas in (187) it is an incredulous question, equivalent to an assertion. Actually, summarizing may be seen as an instance of assertion enhancing. Only the view point or the profile, as cognitive linguists would say, is different. **De** acts prospectively, from the speech

act it enhances toward some expected consequence (verbal or not); **me** acts retrospectively, from the speech act it enhances to the previous verbal or non verbal context of which the speech act is a consequence.

In combination with **didu** as in (188), **me** constitutes a quasi conjunction, roughly meaning 'contrary to what precedes, the fact is that...', a special case of summarizing, then.⁸¹

Syntactically, sentence adverbs would seem to call for the same characterization as ideophones, viz. PCL[ADV]. As we just saw, however, they differ from them in having sentences, not VPs, in their scope. This means that sentence adverbs ought to be introduced by a rule like the following one:

(190) $S \rightarrow S, \text{PCL}[\text{ADV}]$

Of course, S in (190) can be [+Q] or [+IMP], with the understanding that a sentence not marked for Q or for IMP (i.e. not a question or an order) is an assertion. Item specific LP statements are then needed to ensure correct placement of the particular adverbs. For **anta** and **didume**, I propose

(191) $\text{anta} < S[+Q]$

(192) $\text{didume} < S$

For **de**, **nan**, and **me**, we only need to ensure that they follow the head of the sentence(s) they modulate. The parenthesized plural is justified by the fact that in, e.g., (183) **de** is postposed to the lower predicate **karu**, but it could equally well follow the higher one **n konta u ba**. In either case, what is modulated is the whole assertive proposition 'I had told you that...' Likewise, in (187), **me** follows **asin** 'so' which may indeed be considered a predicate. It could also be postposed to the lower VP (**asin ku fulas bin konsigi ciga Kansala me**). Note finally that, whatever their position, sentential adverbs are always strongly stressed.

The most characteristic feature of sentential adverbs, though, is that they bear on speech acts rather than on propositions. More accurately, they do not modify or nullify the truth (or semantic) value of a given proposition in a given context — as, e.g., negative or interrogative items do — but they modulate the pragmatic value of the said proposition for the participants in the interchange. This does not render the semantic domain irrelevant, however, since, as we saw, sentential adverbs also permit the hearer (or the overhearer) to infer something about the truth value of the modulated proposition — expected to be {1} with **de** and **me**, {0} with **anta**.⁸² I therefore propose that a grammar of Kriyol should include pragmatic rules like the following:

(193) (a) Given S, not a question or an order, if you (the asserter of S) strongly believe that S is true, expect or expected it to be effective in some way, and want this belief and expectation to be explicitly known, then append **de** to S.

- (b) Given S, an order, if you (the giver of S) strongly believe that S should be effective in some way (i.e. obeyed), and want this expectation to be explicitly known, then append **de** to S.
- (c) Given S, not a question or an order, if you (the asserter of S) strongly believe that S is true in spite of whatever was or might have been said or implied or thought, and want this belief to be explicitly known, then append **nan** to S.
- (d) Given S, possibly a question but not an order, if you (the asserter of S or the questioner with S) consider it to be the (true) consequence of whatever occurred previously in the context of the ongoing interchange, and want this opinion to be known explicitly, then append **me** to S.
- (e) Given S, not a question or an order, if you (the asserter of S) strongly believe that S is true but is in contradiction with whatever occurred (or was believed to occur) previously in the context of the ongoing interchange, and you want it to be known explicitly, then append **didume** to S.
- (f) Given S, a question, if you (the questioner) expect it to be answered with a denial, and want this expectation to be known explicitly, then append **anta** to S.

Note that the cooccurrence of **anta** and **me** as observed in (186) is provided for by these rules which, conversely, make it an expected fact that **anta** and **de** or **de** and **me** or **de** and **nan** will never be used simultaneously.

This concludes our survey of Kriyol predicates. In the next chapter we will examine the Tense/Aspect and agreement features that bear on them.

Chapter 3

Tense and Aspect

Tense-Aspect (TA) features are those features of VP that must be properly included in the feature set of the mother S, inasmuch as their semantic scope extends over the whole proposition. (In that sense, they constitute a non transformational equivalent of Fillmore's M — see Fillmore (1968) — or of the various versions of AUX alias INFL alias I current in TGG.)

TA features are often treated together with features instantiating the 'agreement' of the verb with its subject and/or object. Kriyol verbs do not agree with their subjects or objects in any visible way, which I will express with the following, language specific FCR:

- (1) FCR: [+V, -N, BAR 0] \Rightarrow \neg [AGR]

As far as the realization of Tense-Aspect is concerned, languages seem to belong to (at least) two major categories. The first, of which Portuguese is a typical representative, exhibits morphological incorporation of the TA values into the verb forms (see Sadock 1985, 1990, 1991 and Baker 1988 for the notion 'incorporation'). Consider, e.g., Portuguese *vejo* 'I see' vs. *vi* 'I saw'. Those are the languages traditionally called "inflectional", which may be accounted for by providing VOs with a VFORM feature, plus various TA and PER(son) features, and leaving morphology do the job of bringing them all together, in parallel with syntactic elaboration, as in the Autolexical framework (see Sadock 1985, 1991). In the second group of languages, no morphological incorporation occurs; TA features are either not spelt out (e.g. Chinese), or appear as autonomous or cliticized words (so-called 'particles').

The preceding description makes it plain that Kriyol belongs to the latter type. It is also a fact that all languages surrounding Kriyol, except of course Portuguese, belong to it. Consider, for instance, the following Mandinka examples from Rowlands (1959):

- (2) N ka táa bólong dáa le la.
I TMA go river side EMPH on
'I go to the riverside.'

- (3) I y' aa bée dómo le.
 they TMA it all eat EMPH
 'They have eaten it all.'

Here, Tense-Aspect features are manifested through autonomous words (*ka* 'Simple Imperfective Indicative', *ye* 'Simple Perfective Indicative'), while person, etc. features are expressed by clitic pronominals, exactly as in Kriyol. Furthermore, it is a well-known fact that this typology is shared by all creole languages, for reasons that have been variously assessed (see, i.a., Bickerton 1981).

In the following, I will not feel compelled to justify my already mentioned assumption that 'aspect markers' ought to be analysed as auxiliary verbs. After all, a restrictive theory of the lexicon such as that which goes with the (G)PSG or AS frameworks does not give them much leeway in being anything else. On the other hand, I will present as accurate a characterization as possible of the semantic import of the TA expressions in Kriyol in order to show that Kriyol auxiliaries are indeed uniquely aspectual, whereas Tense is expressed by other means. I will also have to be much more specific about what happens when no auxiliary is used. One result of the inquiry will be to suggest that the two types delineated in the preceding chapter, viz. aspect auxiliaries and Ad-verbs, may not be all that distinct after all.

3.1. The expression of Aspect

Slightly paraphrasing Comrie (1976), I will define Aspect as referring to the inner constituency of a course of events or a state of affairs (also see Isačenko 1962). In contrast, Tense may be defined as referring to the interval during which a course of events or state of affairs is said to be predicable of some entity (on the notion 'interval' see McCawley 1981:340-358; also Enç 1987). Aspect and Tense are thus denotational expressions embodying conceptual primitives in the sense of Johnson-Laird (1983). For the purpose of semantic interpretation, they may be conceived of as operators on VPs.

Two basic meanings seem to be universally subsumed under the denotational expression Aspect, viz. Perfective (PF) and Imperfective (IPF) (see Comrie 1976; Forsyth 1970).¹ A perfective course of events or state of affairs is represented regardless of its inner constituency, 'as a whole'. The inner constituency of the imperfective counterpart, in contrast, is what is focused on. Obviously, then, a Boolean notation such as [\pm Perfective] is inadequate for this contrast, for there is no sense in which it might be said to rest on the mere presence vs. absence of a discrete feature. Nearer the truth, at least for certain types of languages (e.g. Russian), are accounts where PF-IPF constitute a privative opposition, one term

marked *in toto*, the other unmarked (see Forsyth 1970). Put differently, there is a feature [A] whose two values are [PF] and [IPF]. These values contrast more or less in the same way as do two contrary expressions within one semantic domain, e.g. 'now' and 'before', that is after the fashion of two atomic, primitive concepts. With a few modifications, this is the analysis I shall adopt for Kriyol.

The PF-IPF contrast seems indeed an accurate depiction of the values of Aspect in Kriyol. A complication comes from the fact that, while PF has one expression, namely the bare verb, two different auxiliaries, **na** and **ta**, are linked to imperfective representations. I will therefore review these forms, trying to explain them in a principled way. Only matrix clauses will be examined, and everything that is said below is only valid for them. This must be kept in mind all along. The values of TA in embedded clauses is a matter for Chapter 5.

3.2. Perfective

Consider these examples:

- (4) Jugude ciga cif. (MM)
 vulture arrive smoothly
 'The vulture landed smoothly.'
- (5) N sibi so kuma nya pirkitu karu. (I)
 I know only KUMA my parrot expensive
 'All I know is that my parrot is expensive.'

No aspect auxiliary appears in them, and they are interpreted as referring to perfected, i.e. complete processes. In (4), the verb denotes an event, a telic process, so that 'complete' is standardly understood as completed. Hence the translation as a preterite in English, a *pretérito perfeito, simples (chegou)* or *composto (tem chegado)*, in Portuguese. In (5), in contrast, both the verb **sibi** 'know' and the adjective predicate **karu** 'expensive' refer to states of affairs, atelic processes, and 'complete' is now understood (in an equally standard way) as meaning extant, presently obtaining. Hence the simple present of the English (or Portuguese) translation (see Comrie 1976 on these notions).

The association of the bare verb with a Perfective meaning is indeed remarkable, as it occurs in a number of creole languages, in sharp contradistinction to what obtains in their lexifier languages. I will cite Martiniquais (Damoiseau 1982), Krio, São Tomense (Ferraz 1979), and Saramaccan (Byrne 1987). Indeed, in French as well as in English or in Portuguese, the 'lightest' form of an inflected verb corresponds to the Simple Present, which means that it is associated with Imperfective meaning insofar as the category is pertinent in these languages. Perfective or Past, on the contrary, always require more complex morphology.² It

would be mistaken, however, to elevate this observation to the status of a definitory trait of creolization, as counterexamples are equally numerous, e.g. Haitian, Tok Pisin, or Berbice Dutch (Kouwenberg and Robertson 1988). More to the point of our study is the fact that the self-same association is encountered in the Atlantic languages that make up the substratum as well as adstratum of Kriyol, e.g. Manjaku (Doneux 1967; Kihm and Gomes 1988, Buis 1990) and Balanta (Wilson 1961). I will not push this matter any further, though, if only because no definite conclusions seem to fall out readily from it.

An account of the correlation bare verb-PF interpretation has already been proposed above (see rules (38)-(40) of chapter 2). It proceeds in the simplest way, namely by assuming that in sentences like (4-5), no feature ASPECT or TENSE is indeed borne by the verb.³ VP[-SUBJ] and VP[+SUBJ] (i.e. S), on the other hand, include a finiteness feature. In Kriyol, I think, this feature should be construed as a Boolean feature on VP and its projections, with two values <+> and <-> Now, FCR (40) of chapter 2, repeated below, ensures that finite clauses get an aspectual reading.

$$\text{FCR: } [+FIN] \Rightarrow [A_k]$$

Of course, it is a default reading, determined by the semantic implication of unspecified finiteness. Perfective, i.e. accomplishment for events or actuality for states (including nominal predicates), seems indeed the natural result. Hence (6) as the syntactic tree for (4):

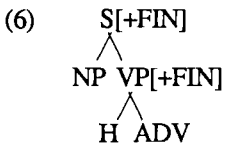

Before concluding this section, another value of the bare verb must be recalled, viz. as an imperative (*bin!* 'Come!'). This was studied in the preceding chapter.

3.3. The *na* Imperfective

This is of course a provisional label that will be modified as soon as the coming analysis provides the ground for a better one. The meaning of the auxiliary is illustrated by the following examples:

- (7) Nyu Sapu na kuda kuma ku i na panya si jintis. (FJDM)
 mister Toad A think how that he A catch his people
 'Mr Toad is wondering how he will catch his men.'

- (8) Si i ka sin, karate na sindi, kaw na burmeju. (HGGN)
 if it NEG so karate A light place A red
 'Otherwise I'll ignite my karate and turn the place red.'
- (9) Gera na forti kada byas mas. (K)
 war A strong each time more
 'The war is becoming fiercer all the time.'

As shown in (7), **na** with an "event verb" implies that the event referred to is contemporaneous with the Reference and/or the Speech time (**na kuda** 'is wondering'), or posterior to them (**na panya** 'will catch' — see Reichenbach (1947); Hornstein (1977); Muysken (1981); Goldsmith and Woisetschlaeger (1982); Landman (1992)). With adjectives, on the other hand, the implication is, as already mentioned, that of a continuing process of reaching the denoted state, either in the present as in (9) (**na forti** 'is strengthening') or in the future as in (8) (**na burmeju** 'will turn red'). Note that under no circumstances could **na forti** and **na burmeju** simply mean 'will be strong/red', a meaning that could only be expressed by using the copula **sedu** (**na sedu forti/burmeju**).

The evidence in (7) is of course reminiscent of the English *be-ing* progressive form which may likewise refer to a present ('I'm writing') or a future ('I'm leaving tomorrow') event (Goldsmith and Woisetschlaeger 1982). (Note that (7) is from a comic-book, so the progressive interpretation of **na kuda** is guaranteed by the accompanying cartoon which shows Mr Toad sitting deep in thought.) However, the notion 'progressivity' lacks explanatory power, as it is not of itself linked to such a dual interpretation. Portuguese, for instance, has an undoubtedly progressive construction (*estar a V* or *estar Vndo*) that cannot refer to a future event (see Corôa 1985). And the same is true of the substratum languages, e.g. the Manjaku *ci di* ('be in') + Infinitive construction. What is clear about the **na** form is that it is Imperfective, as it tells us about the inner constituency of the event or state of affairs. But we need something more in order to account for its precise meaning.

I would like to suggest that the notion "specificity" could be put to good use here.⁴ A noun is said to be specific when it denotes a particular object that one could point at were one given the chance ('the computer I'm using', 'the unicorn I feed in my stable', 'the square circle I drew yesterday', and so forth — see Jackendoff's 1983 concept of 'token identity'). It is non-specific, in contrast, when no particular token can be spotted as being its denotation ('unicorns can't stand stables'). In other words, specificity is what is expressed by the logical formula for definite descriptions, viz. $(x: \forall y (x \neq y))$, the x such that everything else is different from it. Similarly, a time form⁵ may be considered specific when it denotes a clearly delineable event or state of affairs, i.e. something I will call, following Erving Goffman, an *occasion*. An occasion is to time what a (theoretically) showable object is to space ('In the beginning, God created the heaven and the

earth'). If no special occasion is intended, then the time form is non-specific. Actually, this is an application of the capacity to distinguish between types and tokens which probably underlies deixis and anaphora as well (see the widespread notion of deictic vs. anaphoric tenses). The cognitive primitiveness of the feature is thus warranted, insofar as anything can be in the field (also see the notion of 'boundedness' in Talmy 1988).

Progressivity as in the first half of (7) is readily explained by combining imperfectivity with specificity. A specific imperfective time form of an event verb is indeed interpreted as denoting an uncompleted occasion, i.e. something that is presently happening with Event, Speech, and Reference times all coinciding (see Reichenbach 1947; Muysken 1981). Unless it is plain for the speaker and/or the hearer(s) that the occasion is not taking place, as when we say 'I'm leaving' while remaining seated. In that case, our understanding that an occasion, i.e. something "real", which isn't over yet is meant, and some cognitive principle akin to Grice's conversational maxims ('Do not say more than is necessary') or Goffman's Felicity Condition ('Assume the speaker is not insane' — see Goffman 1986) will automatically ensure that the utterance is associated with the only conceivable meaning, viz. that the occasion is about to occur, as good as already occurring, in a word. This takes care of the second half of (7) and of (8). Note that "proximate" or "near" future is a misnomer, since the actual duration of the interval between S, R and E is in no way implied. It may range from a few centiseconds to aeons. Subjective certainty, on the other hand, is certainly implied since, as no formal difference is made between an observably occurring occasion and one that is not observed as taking place, the latter, as suggested, may only be understood as having to occur in some future imbued with the same degree of certainty as the present time. Other ways of expressing the future do not share this implication (see below). I will call 'Prospective' (see Comrie 1976:64ff) this value, in order to distinguish it from more purely "temporal" future expressions.

States, in contrast, are never specific unless there is some way of denoting a particular occasion when the state obtains. This is realized by transforming the state into an event, no longer something to be in, but something to be entered into. Hence the 'inchoative' interpretation of (8) and (9). No other interpretation would be consistent with specificity, since an already existing or a future state is a continuous, non limited entity that cannot, by definition, be broken down into circumscribed tokens. Only through a notion like "becoming" can such a reduction to a point in time, i.e. specificity, be achieved, since what is now in focus is the event, the occasion when the state comes into being. Hence also the fact that the

time of the event (unless it is Past as in **kaw na burmeju ba** ‘The place was/had been becoming red’ — see above and below) need not, actually cannot be determined and may range from Present to Prospective, as shown in (8) and (9).⁶

To sum up, specific imperfective as expressed with **na** is interpreted as actual present or certain future with event verbs, as ‘inchoating’ state with adjectival predicates. What about verbs with a stative meaning such as ‘be’, ‘know’, ‘want’, and so forth? Interestingly, **na** can then only be interpreted as a future (**n na sedu** ‘I will be’, **n na sibi** ‘I will know’, **n na misti** ‘I will want’, etc.), never inchoatively, although such an interpretation would make good sense (‘I become’, ‘I begin to know’, etc.), nor progressively (‘I’m being’, ‘I’m knowing’). Except with **sedu** ‘be’, such forms are exceedingly rare in actual discourse, where a simple present (i.e. perfective) form is usually deemed sufficient to express the fact that the (mental) state in question does not exist yet but certainly will, given some circumstance, as in (10):

- (10) Si bu ka bin amayan n sibi kuma bu nega juda-n. (AK)
 if you NEG come tomorrow I know KUMA you refuse help me
 ‘If you don’t come tomorrow, I’ll know you refuse to help me.’

This shows it would be erroneous, at least in Kriyol, to assume a ‘stative’ class uniting adjectives with verbs having states or, better said, non-events as their meanings. Actually, only a tripartite division seems adequate: (i) event verbs including all verbs denoting physical states (**sta** ‘be in a place’, **firma** ‘stand’, **dita** ‘lie’, and so forth); (ii) non-event verbs, i.e. **sedu** ‘be’ and mental state verbs; (iii) adjective predicates.⁷ This state of affairs is summarized in the following table:

	Progressive	Prospective	Inchoative
Event	+	+	–
Non Event	–	+	–
Adjective	–	–	+

Let me emphasize again that such notions as Progressive, etc. are used here only as labels indicating the interpretive results of applying the specific imperfective value of **na** to the inherent semantics (in terms of the above tripartition) of a given predicate head. Of course, we are thereby somewhat committed to believing that specificity and perfectivity represent or point towards more plausible cognitive categories than do Progressivity, Inchoativeness, and so forth. Intuitively, so much seems to be true, and I don’t know how I could make any stronger statement, except perhaps by pointing out the transcategorial parallelisms thus offered us, and the greater simplicity of the system attained, none of which considerations is admittedly irresistibly convincing. Since truth is unattainable, let us be satisfied, therefore, with the usual provisional acceptance of an apparently reasonable and effective assumption.

Note, for what it is worth, that other creole languages present similar effects with aspectual auxiliaries that may at least be considered imperfective. For the inchoative value with adjectives, for example, one finds *ti fi-a ap bèl* 'The little girl is becoming pretty' (vs. *ti fi-a bèl* 'The little girl is pretty') in Haitian, or *di wómi tá-wisiwási* 'The man is becoming worthless' (vs. *di wómi wisiwási* 'The man is worthless') in Saramaccan (Byrne 1987:46). As the translations suggest, however, it seems that a process is expressed in these languages rather than an event as in Kriyol. This may be due to a difference in specificity between Haitian *ap*/Saramaccan *tá* and Kriyol *na*, because the aspectual systems are differently organized (see below).⁸

To conclude this section, I would like to say something of the origin of *na*. This is an interesting item, indeed, as it puts Kriyol apart from all other Portuguese-based creoles. Even Cape-Verdean, its historically and structurally nearest cognate, has no equivalent for it. I will return to this peculiarity of Kriyol when the other imperfective auxiliary *ta* has been examined. Etymologically, there is little doubt that *na* is a reflex of the Portuguese compounded preposition *na* 'in the (feminine)', which also entered into Kriyol as a (simple) preposition meaning 'in, on' (see chapter 2). We may therefore surmise that the present construction originates in a locative construction analogous to what is found in substrate languages such as Mandinka (11) and Manjaku (12):

- (11) M be màani-katoo le la. (Rowlands 1959:97)
 I be rice-cutting EMPH in
 'I am cutting rice.'
- (12) Bu ci ri ukiy. (Buis 1990:63)
 they be in dancing
 'They are dancing.'

Of course, the Portuguese construction *estar fazendo* 'to be doing', very much in use during the 16th century (see Said-Ali 1971:354ff),⁹ must also be mentioned. No direct derivation can be assumed, however, even not taking into account the semantic difference indicated above. Indeed, the constructions shown in (11) and (12) are clearly PPs headed by a post/preposition (*la, di/ri*) and subcategorized for by a locative verb (*be, ci*). Portuguese *estar fazendo*, on the other hand, is structurally non distinct from, e.g., *estar contente* 'to be satisfied', i.e. from an adjectival predicate headed by a verbal copula, except for the fact that the gerundive may govern an object. As already suggested, and as we shall see more in detail in the following, neither analysis fits for Kriyol.

3.4. The *ta* Imperfective

The following examples illustrate the basic semantics of this form:

- (13) Kasisa ka ta bay sinema gosi ma antis e ta bay ba. (I)
ghost NEG A go cinema now but before they A go PAST
‘Ghosts don’t go to the movies now, but formerly they used to.’
- (14) Lubu ta branku. (I)
Hyena A white
‘Hyenas are white.’
- (15) Tudu ku na pasa el i ta sibi. (I)
all that A happen he[_{TOP}] he A know
‘Whatever happens, he knows it.’

With an event verb as in (13), the interpretation is that of an habitual or indefinitely iterated process. With an adjective predicate as in (14), *ta* indicates that the quality or state is a permanent, inherent one. Compare with (5) **nya pirkitu karu** ‘my parrot is expensive’; expensiveness is not an essential quality of parrots in the sense that whiteness is of hyenas — although it is not impossible to consider it so, so that **nya pirkitu ta karu** is a conceivable, referentially slightly distinct utterance. On the other hand, **nya karu ta branku** (instead of **nya karu branku** ‘My car is white’) makes little sense in isolation unless we imagine a parallel universe where cars are necessarily white. It becomes a meaningful expression, however, if the context makes it clear that the quality is limited to one exemplar of the concept, as in:

- (16) Kada byas ku n ta laba l nya karu ta branku. (I)
every time that I A wash it my car A white
‘Every time I wash it, my car turns out white.’

In (16), ‘my car’ is necessarily interpreted extensionally, i.e. as the car I now possess, and it is of course implied that it was white all the time, although it did not show until I washed it. In contrast, *ta* would be excluded from a context where ‘my car’ must be understood intensionally, i.e. as any car which happens to be mine, as in:

- (17) Kada byas ku n ta kunpra un karu, nya karu (*ta)branku. (I)
every time that I A buy a car my car white
‘Every time I buy a car, my car is white.’¹⁰

Also note that, primarily with adjectives denoting mental or physiological states such as **dwenti** ‘ill’, **kontenti** ‘happy’, and so forth, a different construction is often found, viz. with **sta**, normally a locative copula meaning ‘be [somewhere]’ (e.g. **n sta dwenti** ‘I’m ill’). Now, this is not a variant of the construction just examined. Rather, its meaning appears to be exactly the opposite, as **n sta dwenti** implies (or expresses the hope) that my illness will be temporary, and is thus quasi

synonymous with **n dwenti**.¹¹ **N ta dwenti**, on the contrary, would imply valetudinarity. I will therefore assume we are dealing here with a borrowing from (or an interference of) Portuguese, where the contrast is between *estou doente* 'I'm being ill' and *sou doente* 'I'm an ill man'. It is the latter that translates into Kriyol as **n ta dwenti**, whereas the former corresponds to **n (sta) dwenti**. The formal shuffling betrays the fact that Portuguese and Kriyol are organized quite differently in the present domain. We will return to this.

Both these characteristics, habituality and essentiality, are readily analysed as interpretative consequences of combining imperfectivity with non-specificity, where it should by now be clear that, by the latter, I mean that it is not an occasion, a token, that is denoted, but rather a type. I will therefore define **ta** as a non-specific imperfective auxiliary.

Mental state verbs give rise to an interesting observation. Consider (15). The person referred to is a 'super-hero' endowed with fabulous powers, including that of always knowing whatever is happening in the world. Here, habituality and essentiality become indistinguishable, and this is what comes regularly from combining mental state verbs with **ta**, even in more down-to-earth cases like (18):

- (18) Kansera di bida no ta kungsi-l. (AK)
 suffering of life we A know it
 'The sufferings of life, we know them well.'

Even the most 'stative' mental state verbs like **misti** 'want' can be combined in this fashion, with the same effect. This shows that, contrary to what we observed with **na**, adjective predicates and mental state verbs more or less form one class when conjoined with **ta**, which confirms that interpretations such as Progressive, Habitual and so forth are indeed results that vary according to the inherent features of the elements combined.

As for the origin of the form, it probably comes from Portuguese infinitive *estar* or 3SG present indicative *está* (colloquially reduced to [ta]). As is clear from what precedes, there is no semantic continuity, however, between the Portuguese verb, which denotes a temporary location or state, and the Kriyol auxiliary. We may speculate that, in some previous stage of the language, **ta** covered the whole field of the imperfective as it still does in Cape-Verdean and Saramaccan, and that the distinction in terms of specificity is a later, and as yet unexplained, creation. The following section will be devoted to this split within imperfectivity in Kriyol.

3.5. Imperfective vs. Imperfective

It is indeed a peculiarity of Kriyol that this tripartition of two Imperfectives opposed as to specificity and an unmarked, redundantly specific Perfective.¹² Among Portuguese-based creoles of Africa (I will limit myself to these), only São Tomense presents a triple contrast of unmarked Perfective vs. Habitual-Future-Conditional *ka* vs. Progressive *s(a)ka* (Ferraz 1979:81ff) Even though Ferraz does not use the same analytic categories as I do, it is clear that the cognitive field is divided up differently in the two languages. Cape-Verdean, on the other hand, presents a simple division where unmarked Perfective contrasts with Habitual-Progressive *ta*. This is the same (?) aspectual system as one finds in Saramaccan and Martiniquais (with *ka* corresponding to *ta*). It should be compared with the Haitian system, where an unmarked Perfective-Habitual is opposed to Progressive *ap*.¹³

Kriyol appears thus rather different from other creole languages on this count (to say nothing of its superstrate). But it does not seem to be any closer to its substrate languages either, since they apparently pattern more like Cape-Verdean and other well-behaved creole languages (according to Bickerton 1981). (At least this seems to be true for Mandinka and Manjaku, pending further investigation.) Thus, Kriyol looks definitely as if it had innovated with its contrast of two Imperfectives. Hence the interest of examining this contrast more at length.

The basic contrast is manifested in the following minimal pair:

- (19) N nabibi binyu. (AK)
 I A drink wine
 'I am drinking wine.'
- (20) N ta bibi binyu. (AK)
 I A drink wine
 'I drink wine.'

As a statement I'm now making while rewriting this chapter for the *n*th time, (19) is false in Kriyol as well as in English. (It can be rescued in Kriyol by being interpreted as a Future, 'I will drink wine (when I stop working)'.) There is no problem, on the contrary, with (20) which implies that I usually drink wine, that I like to drink wine, not that I am actually drinking some. So (20) is true, even though there is not the smallest bottle on my desk. This is of course a direct consequence, as well as an especially clear illustration, of the [\pm Specific] contrast.

The contrast may also manifest itself syntagmatically as in (15) above. The super-hero's universal knowledge (*el i ta sibi*) is indeed presented as a background (in the sense of Weinrich (1971); see also Reinhardt (1986)) that is constantly applicable to the series of events occurring in the world (*tudu ku na pasa*). It is

plain, then, that the relevant contrast is between the non-specificity of the ever existing state of knowledge as opposed to the specificity of each and every event that is an object of this knowledge. Again, the derivative character of such notions as 'iterativity' comes to the fore. What indeed should be more iterative than a series of (possibly identical or similar) events? And couldn't a constantly reapplied knowledge be said to be iterative as well? No deep-seated cognitive contrast can be built upon such bases.

Conditional sentences are another context where both Imperfectives regularly contrast. Consider (21) and (22):

- (21) Si bu konta-n ba el es tudu ka na ten. (I)
 if you tell me PAST it this all NEG A have
 'If you had told me about it, there wouldn't have been all this.'
- (22) Si algin oja-u i ta pensa kuma i Zé. (I)
 if somebody see you he A think that it Zé
 'If somebody saw/sees you, he'd/'ll think you are Zé.'

A generally holding correlation can be observed in these examples, viz. that between the counterfactuality of the condition in the protasis and the use of **na** in the apodosis, as against the possibility of the condition and the use of **ta**. In either case, the antecedent verb is aspectually unmarked, and counterfactuality is signalled by the Past marker **ba**. An explanation for these facts in terms of specificity may run as follows. The counterfactuality of the condition, i.e. the fact that it remains finally unrealized, entails that the interval of the consequent (the time when *x* would have been the case) is totally enclosed within the possible world (or mental space in the sense of Fauconnier (1984)) invoked in the antecedent. In other words, the consequent may then be viewed as an occasion of this imaginary world, a unicorn-object that exists in it, hence to be marked as specific. On the contrary, when the condition is still an open possibility as in (22), the interval of the consequent becomes necessarily unbounded, since its realization remains an undecided issue that depends on the condition becoming effective at some time. It cannot therefore be considered an occasion and has to be marked as non-specific.

As a result of this view of things — specificity in a counterfactual world vs. non-specificity in a possible world — no difference is made in Kriyol between the traditional categories of present irrealis and potential (see the alternative translations of (22)). The following example would seem to be an instance of the former:

- (23) Si n sibi no ta bay di la. (I)
 if I know we A go of there
 'If I knew, we would go that way.'

Actually, this sentence was uttered by a driver as he realized he had just missed the shortest way at a crossroad. What seems to have been crucial then is the (subjective) fact that, in the circumstances, the driver could consider he was still able to choose the best way (as he was not yet through the crossroad) even though he never even did so much as suggest that he might turn his wheel in this direction. A few seconds later, when it was definitely too late to (safely) do anything about it, he might have expressed the situation saying *si n sibi ba no na bay di la* 'If I had known we would have gone that way'.

Such a configuration of aspect markings in conditional sentences is, I think, one of the strongest support for the cognitive adequacy of the [\pm Specific] category as applied to time representations.

The counterfactuality indicator *ba* can be reiterated along the sentence, as in this example:

- (24) *Si n sibi ba n ka na bin ba li, n na fika ba na*
 if I know PAST I NEG A come PAST here I A stay PAST in
 Bisaw. (DR)
 Bissau
 'Had I known, I wouldn't have come here, I'd have stayed in
 Bissau.'

According to all informants, (24) would keep exactly the same meaning if *ba* was deleted from the apodoses. This optional 'counterfactuality concord' may be paralleled with the sequence of tense rule of Portuguese (*se eu soubesse* [past subjunctive] *não vinha* [imperfect indicative] *cá*), and may reflect some superstratal influence, although nothing forces us to this assumption.

Notice that the association of *ta* with potential, hence non-specific, predicates is not restricted to overtly conditional sentences:

- (25) *I kume-u, amanyan no ta padi utru.* (I)
 he eat you tomorrow we A conceive other
 '(If) he [Lion] eats you, tomorrow we'll conceive another [child].'
 (26) *Kada kin kay i ta masa i pocoli.* (I)
 each who fall he A tramp hecrush
 'Whoever falls, he [Lion] tramps over him and crushes him under
 his feet.'¹⁴

Constructions such as these gave earlier scholars the impression that *ta* was a future marker (see Wilson 1962). Actually, it is as a secondary effect of the basic semantics of *ta* that the predicates which it marks can, obviously, only assume reality at some time yet to come.

In connexion with the present exploration of the intricacies of imperfective meaning, I would like to come back to the contrastive interpretations of subjects of which some quality is predicated. Clearly, *lubu in lubu ta branku* can only be

interpreted intensionally, as denoting whatever is a hyena, i.e. $[\lambda x P(x)](\text{hyena})$ & $P = (\text{be-white})$, whereas we saw that **nya karu** in **nya karu ta branku** must be understood in extension, i.e. $[\lambda P \exists x P(x)](\text{be-white})$ & $x = (\text{my car})$. This confirms that the contrasts specific vs. non specific and extensional vs. intensional are not coextensive. Indeed, **lubu**, as opposed to, e.g., **es lubu** 'this hyena', is necessarily a generic expression (out of context), so that only a general or essential quality can be predicated of it, hence the non specific value for the imperfective aspect. In this case, genericity and intensionality do indeed presuppose each other. **Nya karu**, on the other hand, is ambiguous (compare, e.g., *My car is a Renault* vs. *My car has always been my most precious possession*). Suppose it is taken in the generic, intensional sense of 'any car that happens to be mine', i.e., simplifying a lot, \wedge 'my-car'. Again, any quality predicated of \sim 'my-car' will have to be general enough to be true of all possible extensions of the concept. *Be-polluting* would do, but, given our knowledge of the world, *be-white* certainly does not qualify. The only way such a property can be meaningfully predicated of *my car* with a generic interpretation, then, is by constructing a contrastive context where the whiteness of my (extensional) car, i.e. \sim 'my-car', stands against a background of non-whiteness due to, e.g., dirt. The quality can now be construed as essential to the thing that is my car, contrasting with the accidental, if perhaps habitual, character of its apparent absence. That is to say, we are back to the case exemplified in (15). The context — possibly implicit — crucially contributes in putting us on the track of the required extensional interpretation (see (16)). The overall meaning (or lack of it) of X-(NP ta AP)-Y thus results as a compositional function of the inherent meaning of the aspect verb and of the logical construal of the subject of the predication.

To sum the matter up, it seems that Kriyol is indeed organized originally in this domain of attributing a quality to some entity, and this is seen quite vividly when one compares it with Portuguese. As already indicated, Portuguese uses two copulas, *ser* and *estar*, according to whether the quality is temporary or lasting. This would seem parallel to what Kriyol does, except that what is crucial in Portuguese for deciding between *ser* and *estar* is the semantic type of the adjective itself. That is, all things being equal, *doente* 'ill' will tend to go with *estar*, and *branco* 'white' with *ser*, given the way these qualities are normally conceived of. Consequently, a sentence like *o meu carro está branco* will be anomalous in most contexts to express the proposition that my car is white, and hyenas and cars do not differ on this count. Kriyol, in contrast, takes as crucial, or so it seems, the worldly characteristics of the object that is assigned the quality, to the effect that one and the same quality may be considered essential or not depending on what it affects, e.g. a hyena or a car.

3.6. An overall view of the expression of Aspect

To sum up, the ‘aspectual system’ of Kriyol consists of three values, (specific) Perfective, specific Imperfective, and non-specific Imperfective, which exhaust the possible Aspect specifications. Perfective is the interpretation that is automatically — thanks to FCR (40) of chapter 2 — given to finite sentences not otherwise specified for their temporal constituency. What about \pm Specific Imperfective? Should it be considered a set of features on VP, on a par with [PAST] for example?

I will propose what I think is a simpler and more general solution. Let us assume that specific Imperfective and non-specific Imperfective are the meanings of the verbs **na** and **ta** respectively. Of course, such meanings could hardly be made explicit were one to write down dictionary entries for these items. But neither can the meaning of ‘be’ be made explicit. For example, the entry for it in *Longman’s Dictionary of Contemporary English* consists entirely of examples of its use. Compare with the definition of the immediately following item *beach*: ‘a shore of the sea or a lake covered by sand or small stones’ (p. 77). There is no problem here, given some Wittgensteinian notion of what meaning is (also see Langacker 1989 on the meaning of grammatical morphemes). The lexical entry for **na** will thus look as follows:

- (27) <**na**,
 [[-N], [+V], [BAR 0], [+AUX], [SUBCAT x],
na’>

The whole semantic complex loosely denoted as specific imperfective is included in the meaning **na**’.

Consider now that **na** and **ta** certainly are no event verbs, but rather kinds of state verbs. In finite clauses, therefore, **na** and **ta** are bare state verbs governing non finite VP complements. Given FCR (40), they will then receive an aspectual reading, namely perfective implying here present relevance, which is exactly what we need in order to account for the final interpretative result.

The advantage of this solution, in terms of conceptual economy, is that we can dispense with a syntactic feature A and its values after all. [FIN] now does the whole job, and aspect is sent back where it belongs, that is into semantics. I will nevertheless continue to use such terms as Perfective, etc. for the purposes of actual description, although it must be clear that they are nothing but cover labels that have no intrinsic cognitive reality.

Moreover, discarding A means suppressing the last syntactic difference between aspectual auxiliaries and Ad-verbs, and entrusting semantics with the full task of separating them. This is good because the prohibition that was suggested earlier against aspectual auxiliaries governing each other proves too stringent after all, in view of examples like the following:

- (28) Tudu ora ku fulas purpara se ataki na Boe i ta kontra Janke
 all time that Fulas prepare their attack on B. it_A happen J.
 Walli nunde ku i sinta i ta na oja elis. (MK)
 W. where that he sit he_A see them
 'Whenever the Fulas prepared an attack on Boe, Janki Walli could
 see them from wherever he happened to be camping.'

The translation attempts to convey the complex aspectual relations whereby iterativity (**ta**) gets combined with simultaneity of one event with another (**na**). In the end, the only constraint that has to be maintained is that against sequences of identical auxiliaries (***na na, *ta ta**), which is obviously semantic in character. We are thus led to the following ID rule, a condensation of rules (43-44) of the preceding chapter:

- (29) VP[-SUBJ,+FIN,+AUX] → H[12], VP[-FIN]

(Rule (45) for **jumna** has to be kept separate.) Rule (29) looks remarkably similar to the rule that introduces *to* in infinitives in English (see Gazdar et al. 1985:115). This is why I chose to register **na, ta**, and the Ad-verbs as V[12], taking this category to be the universal category for auxiliaries. One might feel anxious about allowing the complement VP to be itself [+AUX], lest this should open the road to infinite recursion of the rule. We shall see below that this is not a real problem. Moreover, it is not necessary, it seems, to have a special LP statement in order to ensure that aspectual auxiliaries must precede Ad-verbs (**i ta jumna i VP** vs. ***i jumna i ta VP**). Actually, such precedence is not always the case, and, as will be seen, semantics should suffice to guarantee that the modification hierarchy goes down the way it does in the case under consideration, and that it makes no sense to have it otherwise. It might be, however, that (29) is not the last word on the topic, and that it requires some further modification. More on this later.

Tense is also expressed in Kriyol, namely as a Past vs. non-Past contrast where the latter has no segmental realization, while **ba** spells out the former. We already encountered this morpheme, and we will now examine it more at length.

3.7. Past

I will be interested here in both the inherent semantics and the structural position of the Past marker *ba*. Its historical origin will also be looked into. Here are a few more examples of its use that cover, I trust, all possible occurrences:

- (30) N konta u ba kuma nya pirkitu karu de. (I)
 I tell you PAST that my parrot expensive DE
 'I had told you though that my parrot is expensive.'
- (31) A! n diskisi ba. (I)
 ah I forget PAST
 'Ah, I had forgotten!'
- (32) Pa ley i yera un prosesu... ley i un prosesu ba... un (I)
 COMP read it be+PAST a process read it a process PAST a
 tarbaju difisil.
 work difficult
 'Reading was a process... it was a process... a hard job.' (see 73)
- (33) I ka el ba. (I)
 it NEG s/he/it PAST
 'It wasn't s/he/it.'
- (34) Mandingas kontinwa nega ba rasa. (MK)
 Mandings continue refuse PAST pray
 'The Mandings kept on refusing to pray [in the Muslim way].'
- (35) E gaža li i ten un kaw ku n ciga di oja l ba nel. (HGCS)
 this girl here it have a place that I arrive of see her PAST in+it
 'This girl, I already saw her some place.'¹⁵
- (36) Kil omi ba i kin. (I)
 that man PAST it who
 'Who was that man?'

3.7.1. The semantics of *ba*

Let us first examine what exactly is the meaning of Past in Kriyol. Judging by the glosses above, it is clearly parallel to what other authors have called 'Anterior' (see, e.g., Bickerton 1975, 1981). That is to say, it denotes an interval that is anterior to an interval of reference that is itself anterior to the time of speech. In Reichenbachian notation:

- (37) PAST: E ___ R ___ S

In (30), for instance, the event *telling you* is separated from the time of speech by another event that is not mentioned in the sentence, but is nevertheless its real topic, namely that the addressee, the bloody fool, let the parrot be devoured by the cat. Using the Past, plus the sentential particle *de* (see Chapter 2), has the illocutionary effect of emphasizing the discrepancy between the prior warning and

the loss of the bird in spite of it. This effect would be lost, had the speaker used the informationally equivalent Perfective (**n konta-u kuma...**). Note that a roughly similar effect is achieved by using the pluperfect in English, a form that is indeed generally the most convenient translation.

The ERS schema is equally relevant to (31), with E the interval of forgetfulness, and R the time of the recollection. Obviously, the transitions from E to R and from R to S are almost instantaneous in the present case, again confirming that duration as such is not at issue.

The combination of the semantic import of **ba** with that of the aspectual marking of the predicate is of course a central issue. I assume that the verb which **ba** modifies is independently assigned an aspectual value, either directly by FCR (40) if it is bare as in the examples above, or by combining its meaning with that of the aspectual auxiliary that dominates it. When it is associated with the non-specific Imperfective auxiliary **ta**, though, Past may either preserve its own semantics combined with the intrinsic meaning of **ta**, as in (13) where it is explicitly stated that ghosts used to go to the cinema at some entirely bygone period. Or the combination may tend toward something that rather looks like a Portuguese or French Imperfect, i.e. a background tense as in the following, somewhat complex, example:

- (38) Si algin ki ta kungsi n ba ja i bin oja n i
 if somebody who A know me PAST already he come see me he
 ta fala kuma, "A! es li i ciw ba minjer". (I)
 A say KUMA Ah this here he much PAST woman
 'If somebody who already knew me came to see me, he would say,
 "Ah! This guy here had a lot of women".'¹⁶

What is relevant in (38) is the fact that the person who comes to see me (at some unspecified moment) already knew me at the time of his/her arrival. It would of course be absurd to suppose that this acquaintance somehow ceases when we meet, in the same way as I have obviously ceased to forget when I exclaim, 'Ah! I had forgotten' (see (31)). Here the specific contribution of the non-specific Imperfective is clearly to be seen, namely that the process (*knew*) is neither perfected nor self-contained, hence must continue to exist all along on the backstage of some other process (*came*) to which it is semantically, as well as syntactically, subordinated. Past, on the other hand, specifically implies that the background process began well prior to the foreground one (which is further emphasized by **ja** 'already'). Conversely, **algin ki kungsi-n ba ja** would translate roughly as 'somebody who had known me', suggesting that we somehow lost sight of each other in the meantime. The complex form realized as /ta V ba/ cannot therefore be compared outright with an Imperfect or the English progressive

preterite (*was Ving*), after all. This becomes quite clear if we take the verb itself into account, and we replace **kunsi** in (38) by an event verb, e.g. **kuri** 'run'. Now, **algin ki ta kuri ba** becomes semantically bizarre, as it seems to mean that the person came running and had been continuously running for quite a time before s/he came, a physiologically improbable feat if *continuously* is taken literally as it seems it must in the present case.¹⁷ It can only be rescued by interpreting it in the same way as (13), i.e. 'somebody who had run' meaning 'had been a runner' and stopped being one, a somewhat complicated meaning. More ordinary meanings, in contrast, are the following: (a) **algin ki kuri ba** 'somebody who had run' and had ceased to when s/he came; (b) **algin ki ta kuri** 'somebody who runs', i.e. is a runner; (c) **algin ki na kuri ba** 'somebody who was running'; (d) **algin ki kuri**, interpreted as synonymous with (c). In short, it appears that the aspect auxiliary (or FCR (40)) and the tense marker make distinct, if combined, contributions to the overall reference of the predicate, another clear instance of compositionality.

Also note that what precedes holds for central Kriyol. In more marginal, partly "decreolized" varieties, I suspect that **ba** is actually used as an Imperfect ending on the Portuguese model, as is apparent in the following sentence, recorded during the news bulletin on Radio Bissau, a well-known source of deviant constructions:

- (39) Kil asinus yera ba komendadu pa un branku ku na
 that murderers be+PAST PAST commanded by a white who A
 papya ba inglés. (RB)
 speak PAST English
 'Those murderers were commanded by a white man who spoke
 English.'

Obviously, **un branku ku na papya ba inglés** is a direct translation from the Portuguese *um branco que falava inglês*. And so is the passive construction with an agent, a strikingly un-Kriyol feature.¹⁸

It is possible that the same reanalysis is active to a certain extent in (34) where **kontinwa...ba** easily translates as an imperfect in Portuguese. But note that (34) is taken from a historical narrative (in comic book form), and that in narrative and tales generally the mere "remoteness" of Past often overrides its anteriority. This is the case, for instance, in the opening formulas of traditional folktales (**i yera ba un tenpu**, literally 'It was/had been a time', i.e. 'Once upon a time').

With certain types of predicates, the interpretative effect induced by **ba** is even more specific. For example, **i bay ba la** 'S/he had gone there' implies that the person referred to is no longer "there" at the time of speech, and that s/he either returned "here" (where the speaker is standing) or proceeded to some other place; **i bay la** 'S/he went there', in contrast, implies nothing as to his/her present

whereabouts. Similarly, with adjective and noun predicates, Past means that the state or quality are now extinct. A state or quality that are past simply by virtue of being contemporaneous with some perfected event are not marked with *ba*, as shown in (40):

- (40) *Oca nya bajuda riba n kontenti ciw.* (I)
 when my girl return I happy much
 'I was very happy when my girl-friend came back.'

The utterance makes no prediction as to my present state of mind, whereas, e.g., (56) of the preceding chapter (*n ta kontenti ba na kil tenpu* 'I was happy in that time'), definitely implies that I am not so happy now as I used to be then.¹⁹ In terms of the ERS schema, this "bygoneness" implication of Past may be seen as a consequence of having E entirely separated from S by a time interval whose remotest end is taken as R. There is thus no possibility that the state or quality could have endured till the present (S) time.

As for the connexion between Past and counterfactuality (or conditionality), this is of course an extremely widespread phenomenon that is observed in hundreds of languages including, interestingly enough, Portuguese and the substrate languages.²⁰ A more primitive cognitive category than both Past and counterfactuality-conditionality should therefore probably be sought for. I will refrain from speculating further, however, and I will continue to use Past as a descriptively satisfying notion.

3.7.2. *The origin of ba*

Before proceeding to examine the syntactic identity and position of the Past marker *ba*, it is useful to delve a little into its origin, as this may throw some measure of light on the structural issue.

Note first that *ba* (*ban* in the Casamance variety) has its only direct equivalents in the Santiago, Fogo, and Brava dialects of Cape-Verdian (see Meintel 1975; Veiga 1984), that is to say in the Sotavento (leeward) variety, which stands closest to Kriyol generally. Only there do we find *ba* postposed to the verb it modifies as in Kriyol.²¹ In the other Atlantic Portuguese-based creoles, the Past marker appears attached to a base *ta*, viz. *tava* in the Barlavento (windward) variety of Cape-Verdean (Veiga 1984) and in São-Tomense (Ferraz 1979), *tabata* in Papiamentu (Jesus, Philipsen, and Pieters 1978). This complex morpheme, whose meaning seems to be similar to that of Kriyol *ba*, is proposed to the verb it modifies.²²

Comparing these items soon suggests a probable Portuguese etymon for a morpheme whose reconstructed form may be represented as /*ba*/, viz. *-va*, the 1st and 3rd person singular ending of the Imperfect Indicative of the so-called first

group verbs (e.g. *cantar* 'sing', *cantava* 'I/he sang, was singing, used to sing'). In Portuguese, this is a bound morpheme that must be attached to a verb stem of a specified morphological class. In all Portuguese-based creoles except Sotavento and Kriyol, this character was preserved insofar as /ba/ was inherited bound to a stem /ta-/ which is obviously a reflex of Portuguese *estar*. (Note that ['tava] is the colloquial Portuguese pronunciation of *estava* 'was'.) Of course, creolization was instrumental in rendering the form unanalysable in the newly emerged languages (compare with the change of French *était* 'was' into the Past marker *té* in the Caribbean French based creoles).²³

The peculiarity of the Sotavento and Kriyol change is then that /ba/, instead of retaining such a radically limited distribution, extended to all verb stems irrespective of their original morphological classes. The generalization was even more extreme in Kriyol since, as we saw, /ba/ spread to all kinds of predicates, and even to non-predicates, thereby losing its verbal affix status (which it possibly retained in Sotavento). The semantic autonomy of the cooccurring Imperfective and Past markers in Kriyol, as opposed to their combining into something like a background Tense in the other Portuguese-based creoles, may also be a consequence of this development.

The phonetic shape of /ba/, the fact that it is an easily segmented CV syllable, probably helped its reanalysis as a self-standing element. It is also a fact, however, that this factor remained ineffective in all other creoles, except, but to a lesser extent, in Sotavento. This is why it is impossible to dismiss another possible, although much less obvious, origin of /ba/, viz. Portuguese *acabar* 'finish, be finished', with a Kriyol reflex *kaba* 'be finished'. There is no semantic or phonetic impediment, indeed, such that, e.g., *konta ba* 'had said' could not have evolved from something like **konta kaba* (compare the Tok Pisin accomplished marker *pinis* from English *finish*). The plausibility of this reconstruction is heightened if we take the possibility of conflation into account (see Kihm 1989). Manjaku has a verb (*pě-*)*ba* meaning 'finish' which is used, in a kind of serial construction, to express completion (e.g. *a-reala ba* 'he finished eating'; see Buis 1990:51). And the same in Diola-Fogny (see Sapir 1965). The syntactic peculiarities of Kriyol /ba/ would be readily explained given such an origin. Of course, the very logic of conflation entails that the two different etymologies do not exclude one another. On the contrary, we may suppose that both /-va/ and (*a*)*cabar*, the latter reinforced by the phonetically similar Manjaku, Diola-Fogny, and perhaps still other languages, *ba*, had to enter into the process in order for it to go to such extremities

3.7.3. *The syntactic identity and position of ba*

The Tense marker **ba** differs from the aspectual auxiliaries **na** and **ta** in three ways: (i) it follows rather than precedes the item it modifies; (ii) it does not have to be adjacent to this item; (iii) this item may be a noun predicate, or even an element that is not a predicate.

There is nothing to add concerning (i). As for (ii), note that the interposed material is most often an object pronoun as in (30). In fact, given that an object pronoun must be adjacent to the verb that governs it (see Chapter 2), **ba** could not be adjacent to the verb in (30): ***n konta ba u** is grossly ungrammatical. This fact suffices to demonstrate that **ba** cannot be analysed as a verbal affix in Kriyol, since it would not impede the adjacency requirement for the pronoun if it was one (see European Portuguese *eu contava-te* ‘I used to tell you’). In (34), on the other hand, **ba** clearly modifies **kontinwa** ‘continue’, not **nega** ‘refuse’ to which it is adjacent. (**Kontinwa ba nega** is also grammatical.) Similarly in (35) where Past is a feature of the modal verb **ciga di** ‘be/do already’ rather than of the complement verb **oja** ‘see’ (and again **ciga ba di oja I** is acceptable). I have no explanation of why the position of **ba** should oscillate the way it does. Informants do not find any semantic difference between both constructions. The ‘simpler’ one, with **ba** adjacent to the verb it directly modifies is probably preferred in everyday talk ((34) comes from a comic-book story), even though in a sense **ba** does not only modify the head verb in (34) and (35), but also the whole complex VP **kontinwa nega** ‘continue to refuse’ and **ciga di oja** ‘already saw’. I will return to this issue.

Things are different with NP complements. In contemporaneous, central Kriyol, an NP complement can be interposed between the verb and **ba** only if it is monosyllabic, and even so, native speakers are reluctant to accept this construction and much prefer to have **ba** to follow the verb immediately (e.g. **?i kunpra pon ba** vs. **i kunpra ba pon** ‘S/he had bought bread’). The former construction is not judged to be truly ungrammatical, but it is often considered “old” (**antigu**). Whether this judgment points towards some real change in Kriyol, I do not know. I will try, however, to find out what this evidence implies for the syntactic issues at hand.

Finally, (32) and (33) are examples of **ba** modifying noun predicates. As indicated, this construction is only one of two possibilities, the other being the use of the past copula **yera (ba)** (marginally **sedu ba**). Although the latter is certainly expanding now, the former cannot be said to be obsolete and is still widely employed. There are some constraints on the size of the noun predicate to which **ba** is postposed, though. It seems that it cannot exceed one noun and one adjective. For example, **i un prosesu difisil ba** would be acceptable in (32). More complex

NPs, in contrast, such as a head noun modified by a relative clause, are definitely rejected, and the construction using the copula then becomes mandatory. In (36), we see **ba** modifying not the (noun) predicate (**kin** ‘who?’), but a topicalized constituent coindexed with the subject of this predicate (**kil omi_i...i_i**), even though Past would seem to have scope over the whole predicate (‘this man was who?’). Interestingly, the variant with **ba** postposed to the predicate, ***kil omi i kin ba**, was judged ungrammatical.

Let us now try and bring all this evidence together. Obviously **ba** is not a verb, and neither is it a verbal affix, except possibly in an “advanced” variety of the language. I therefore propose to analyse it as an adverb, that is a [+N +V] item with an added feature [+ADV]. Adverb generation has already been provided for in the preceding chapter through ID rule (179), repeated here:

(41) VP → H[n, -AUX], [+ADV], W

Rule (41) allows for the following sentences, among many others:

(42) Prezidenti i riku ciw. (AK)

president herich much
‘The president is very rich.’

(43) N kuri kinti-kinti. (AK)

I run hot-hot
‘I ran fast.’

(44) Yanda fas. (AK)

walk IDEO
‘Hurry up!’

That is, it provides for degree and manner adverbs, as well as for ideophones. And it also provides for **ba**. The [-AUX] proviso is destined to prevent adverbs from ever modifying the aspectual auxiliaries **na** and **ta** (**n ta baja ba ciw** ‘I used to dance a lot’ not ***n ta ba ciw baja**). A problem arises, however. Given the way (29) was formulated, we expect **ba** not to be able to modify Ad-verbs. This expectation is not borne out by the facts: **n yara ba kay** and **n yara kay ba** are equally good expressions for ‘I had almost fallen’. It seems that we need to distinguish aspectual auxiliaries and Ad-verbs in some way, after all.

In order to do this, I will reintroduce the feature [A], not as a lexical feature, but as the lowest realization — via the meaning of **na/ta** — of a semantic feature which is *potent* at the VP and S levels (see Gazdar et al. 1985:223ff.). That Aspect (and Tense) is interpreted over the whole proposition, no matter where it is expressed in the structure, is indeed a fact that the preceding analysis did not take into account, and to which we shall have to return. Meanwhile, I will note this feature [A, ↑], the upward-pointing arrow (freely borrowed from Lexical

Functional Grammar formalism — see Sells 1985) being equivalent to the circling device of Gazdar et al. The lexical entry of **na**, for instance, ought thus to be like (45) rather than like (27):

- (45) <na,
 [[-N], [+V], [BAR0], [+AUX], [A ↑], [SUBCAT x],
 na’>

Ad-verbs, in contrast, do not carry this feature, since they are interpreted at the level where they occur. Nothing need ensue for (29), which spans all auxiliaries. However, (41) must be modified as follows:

- (46) VP → Hn[BAR0, ±AUX], [+ADV], W

The occurrence of predicate adverbs — including **ba** — within VPs is now effectively limited to those cases where the head (be it an ordinary or an auxiliary verb) does not include a feature whose interpretation must occur higher in the tree. (Since [A] is presumably a marked feature, not mentioning it in the rule is enough to exclude it.) This makes sense, considering that predicate adverbs cannot directly modify an item which is not semantically where it seems to be. Of course, we must enter into the picture the fact that **ba**, insofar as it means PAST, is itself interpreted at the S level. This will be done later on.

Given the functional equivalence of VP and NP[+PRD] in Kriyol (see above), rule (46) also predicts that **ba** may modify a noun predicate. The fact will perhaps stand out more clearly if we rewrite (46) as (47):

- (47) XP[+PRD] → Hn[BAR0], [+ADV], W

Observe, as supporting evidence for this rule, that other adverbs than **ba** may modify noun predicates, semantics permitting:

- (48) Bida i kansera son. (AK)
 life it trouble only
 ‘Life is only trouble.’

A crucial difference between **ba** and the other adverbs is linear ordering, insofar as degree and manner adverbs and ideophones may be separated from the head of the constituent they modify by indefinitely many complements of the head:

- (49) I ta fasi kalur na kil prasa ciw. (AK)
 it A do heat in that town much
 ‘It’s very hot in that town.’
- (50) Gatu kume tudu ratu na ntuju bik. (AK)
 cat eat all mouse in attic IDEO
 ‘The cat ate all the mice in the attic.’

As already mentioned, replacing **bik** by **ba** in (50) would result in an ungrammatical sentence. It seems, therefore, that we need a special LP statement for **ba**, not valid for other adverbs. Let us assume the following:

(51) $V0 < N0[+CL] < \mathbf{ba} < N2$

In (51), [CL] means clitic, and it is a feature the necessity of which will be explained later on. The statement says that a clitic complement cannot appear to the left of a verb, that **ba** cannot appear to the left of a clitic complement, and that an N2 constituent cannot appear to the left of **ba**. Zero-level nouns or N1s (i.e. nouns accompanied by a determiner and/or one adjective) and **ba** are not ordered with respect to one another, so that they may appear in either order, at least in some dialects. In dialects where **i kunpra (kil) pon (seku) ba** 'S/he had bought (that) (stale) bread' is considered definitely bad, it is enough to replace N2 with N_n, i.e. a noun phrase of any bar level. We also need a special LP rule for the cases of **ba** modifying a noun predicate:

(52) $N1 < \{<+N +V \text{ BARi}\}1 < \mathbf{ba}$

Rule (52) says that an adjective phrase cannot appear to the left of an N1, and that **ba** cannot appear to the left of an adjective phrase of whatever level ($0 \leq i \leq 2$) and of cardinality 1 (i.e. limited to one head — cf. **i un prosesu difisil ba** vs. ***i un prosesu ba difisil**).

Perhaps one might object to writing special rules for just one item. But note that this item, being an adverb whose meaning is an abstract temporal specification, is indeed very special, actually the only one of its kind in the language.²⁴ Moreover, there is no theoretical ban against rules limited to one or a few items provided (i) the move is vindicated by the evidence of the language, as it is here I believe; (ii) the special rules do not violate general principles which it would be too costly to give up, such as Exhaustive Constant Partial Ordering (ECPO). It is easy to check that neither (51) nor (52) invoke partial orderings that would be incompatible with the expansion of other categories than VP or NP[+PRD].

Rules (51) and (52) thus licence the following trees:

(53)
$$\begin{array}{c} \text{VP}[+FIN,+PAST] \\ \swarrow \quad \searrow \\ \text{V1}[+FIN] \quad [+ADV,+PAST] \\ \swarrow \quad \searrow \\ \text{V0} \quad \text{NP}[+CL] \end{array}$$

(54)
$$\begin{array}{c} \text{VP}[+FIN,+PAST] \\ \swarrow \quad \searrow \\ \text{V1}[+FIN] \quad [+ADV,+PAST] \\ \swarrow \quad \searrow \\ \text{V0} \quad \text{NP} \\ \quad \quad | \\ \quad \quad \text{N0} \end{array}$$

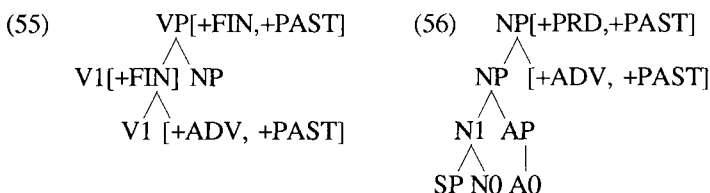

Examples of sentences described by (53-56) are respectively: **i kunpra l ba** ‘S/he had bought it’; **i kunpra pon ba** ‘S/he had bought bread’; **i kunpra ba pon** (...) ‘S/he had bought bread’ (where the virtual NP headed by **pon** may be freely extended); and **i un prosesu difisil ba** ‘It was a difficult process’.

None of the rules proposed so far explains (36), however, where **ba** modifies an NP (**kil omi** ‘that man’) which is not a predicate. Another example is the following:

- (57) Tarbaju di franses i sedu mas utru tarbaju un bokadu pizadu
 work of French it be more other work a little hard
 suma portugis ba na skola primarya. (I)
 like Portuguese PAST in school primary
 ‘French is another matter (that is) a little difficult, as Portuguese used to be in primary school.’

Now (57) could well be analysed as involving a missing (‘gapped’) adjective predicate in the second clause, thus bringing it back to normal. I will return to this issue. Example (36), on the other hand is not surprising in itself, given the adverbial nature of **ba**; after all, **kil omi awonti** ‘that man yesterday’ is a perfectly good construction. The real question is why isn’t it possible for **ba** to modify **kin** ‘who?’. I will try to provide an answer in connexion with the study of questions and question words in Chapter 6.

3.8. Tense auxiliaries

Tense expression in Kriyol is not limited to Past; futurity can also be expressed. One variety of it, labelled ‘Prospective’ has been encountered above as one of the interpretations of the **na** Imperfective. Two more varieties, differently combining Aspect values and Tense, will now be examined.

3.8.1. *Bin* and the specific future

Consider the following examples:

- (58) Kin kungsi si nomi el ku na bin kasa l. (MM)
 who know her name he(TOP) who A BIN marry her
 ‘Whoever knows her name will marry her.’

- (59) I ka sin ku n pensa ba kuma kusa na bin sedu. (FJGK)
 it NEG so that I think PAST that thing A BIN be
 'It isn't so that I thought the thing would be.'

Both sentences contain a clause which refers to an event or a state of affairs that is temporally posterior to the denotation of a commanding clause. Incidentally, (59) compared with (58) demonstrates the absence of anything like a sequence of tense in Kriyol (cf. the alternation *will/would* in English). Formally, the expression is achieved by using the verb **bin**, meaning 'to come', as an auxiliary, and having it modified by the specific Imperfective aspectual auxiliary **na**. The semantic effect thus obtained is quite similar to the so-called 'perfective future' of Russian (see Forsyth 1970), i.e. of denoting an event or state of affairs that is supposed to occur or obtain at some point in the future (not repeatedly over a future period of time). The said point is not necessarily known by the speaker, but the understanding is that it could be dated given sufficient information, e.g. the time when somebody will turn up who knows the girl's name in (58). In (59), the point is 'now' (speech time), and it is future relative to the time of my ratiocination. The following example shows auxiliary **bin** cooccurring with 'full' **bin**:

- (60) Dia ku n bin misti l n na bin bin toma di mi. (I)
 day that I BIN want it I A BIN come take of me
 'And then, the day that I want it, I'll come and take what is mine.'

The best way, I think, of accounting for this evidence is to make auxiliary **bin** another Ad-verb meaning something like 'to come posteriorly'. The plausibility of this analysis is shown by such examples as:

- (61) Abran padi Isak, Isak bin padi Žakob. (V)
 Abraham conceive Isaac Isaac BIN conceive Jacob
 'Abraham conceived Isaac, Isaac (then) conceived Jacob.'
- (62) Asin me ku fulas bin kunsigi ciga Kansala. (MK)
 so ME that Fulas BIN manage reach K.
 'It is then in this way that the Fulas finally managed to reach Kansala.'
- (63) Un barku yera ba pa bay awonti Katyo ma pilotu bin
 a boat be+PAST PAST for go yesterday K. but pilot BIN
 foga ku binyu kaju. (FJGK)
 drown with wine caju
 'A boat was to depart yesterday to Catio, but then the pilot drowned himself in caju wine.'

Example (61) is from the generations of Jesus in the translation of the New Testament. Successivity is here at its clearest. In (62) **bin** registers the fact that the Fulas reached (and took) the city of Kansala only after many endeavours and

episodes during their war against the Mandings, all of which are narrated in the part that precedes this sentence in the story — hence the English gloss ‘finally’. The temporal relations in (63) speak of themselves.

Syntactically, all these examples as well as (58-60) can be described with rule (29). **Bin** denotes mere successivity like its English adverbial equivalent *then*, or like Portuguese *pois*, and its privileged use is thus in narratives where sequences of events are reported, and where each successive event becomes a new time of reference for a following **bin**. When **bin** is modified by **na**, its meaning is unchanged, and **na** contributes its own intrinsic denotation, viz. specific Imperfective, here interpreted as prospective. As a result, the time of speech, the ‘real’ present, becomes the time of reference, and the complex **na bin**, as contrasted with simple prospective **na**, now means that some event or state of affairs will take place or obtain after some other event or state of affairs has taken place or obtained. This is quite clear in the examples. Only after some man guesses her name will the girl get married to this man. I didn’t think before that things would be as they are now. The necessary preliminary may of course be construed as a condition. However, the difference with conditional sentences where **na** appears in the consequent — see (21) **si bu konta-n ba el es tudu ka na ten** — is that the condition is not taken as counterfactual or as possible in some world (in which case **ta** would appear in the consequent), but as merely future, i.e. still unrealized, in this world. There is thus a ‘reality effect’ attached to **bin**, which explains why adding **bin** in (21) would give rise to a semantically ill-formed proposition. This reality effect manifests itself subtly in the following contrast:

- (64) N pudɪ fasi l.
 I can/may do it
 ‘I can do it.’
- (65) N pudɪ bin fasi l.
 I can/may BIN do it
 ‘I may do it (sometime later).’

Kriyol **pudɪ** is ambiguous between the capacity and possibility readings. Capacity is however the default interpretation and it is the one typically assigned to (64) which takes no position as to my actually ‘doing it’ in any real occasion. In contrast, (65) definitely states that maybe (**pudɪ**) I will (**bin**) do it in some future occasion. (Of course, capacity remains implied as a presupposition.)

A few more remarks. Firstly, one may wonder about the advisability of analysing **na bin** as two lexical items rather than, perhaps, one (**nabin**). The move would be tempting in view of the fact that **na bin** is frequently reduced to /nin/, especially among the younger speakers.²⁵ That this process may ultimately result

in a new morpheme cannot be ruled out. For the time being, though, I will keep to the conservative stance of considering /nin/ a phonological, allegro variant of dimorphemic **na bin**.

Secondly, the compositional character of the present analysis must be emphasized. Each element of the semantic complex **na bin** brings its own contribution to the overall meaning of the predicate, as **na** modifies **bin**, which modifies the VP. Notice that we do find cases where the order of the auxiliaries is reversed:

- (66) Ami propi ku bin na kaba di sibi kuma es dus
 I(TOP) self who BIN A finally-do of know that this two
 lingwas li e ka mezmu. (I)
 languages here they NEG same
 'I myself am finally getting to know that these two languages are not alike.'

Here, **bin** dominates the VP /...na kaba di.../, which itself dominates the VP /...sibi.../:

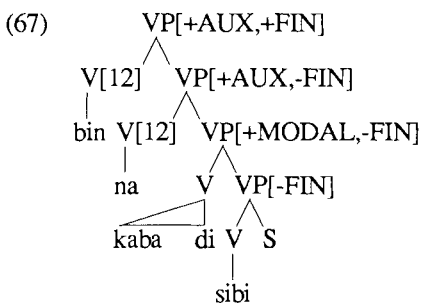

The speaker thus manages to convey the complex message that, after many efforts and setbacks at school (his previous discourse), he is finally coming to the awareness that Kriyol and Portuguese (the two languages he is referring to) are indeed different languages. We are thus led to the conclusion that potentially infinite recursion of the auxiliaries is not something to be dreaded after all, and no provision against it has to be taken in rules — as none was effectively taken in (29). What example (66) demonstrates is that as many auxiliaries may be piled up as hierarchically organized auxiliary concepts wish to get themselves expressed, in full accordance with the Principle of Compositionality (see Dowty et al. 1981; Langacker 1989). The final semantic effect will be a function of the intrinsic meanings of the auxiliaries and, as will be shown below, of the order according to which they modify each other and the VP they all dominate. Note, for instance, how replacing **na** with **ta** yields a quite different meaning:

(68) n pudi ta bin fasi l

This is an alternative way of expressing (65) where the VP /...bin fasi-l/ is further modified by the non specific Imperfective auxiliary **ta**. The interpretative difference with (65) is that (68) implies that, even though I may do it in the future, I am not at present looking forward to any possible occasion when I will do it. In other words, (68) is a vaguer, less committing version of (65). It is worth noting that *n ta bin fasi l, as a finite sentence, is rejected by the native speakers. I will not call it ungrammatical, however, since the grammar may freely generate it, but rather meaningless. The point will be made clearer below.

Another conclusion that must be drawn from what precedes is that aspectual auxiliaries as well as Ad-verbs can also be non finite. Put differently, they can head controlled predicates, as in (67) where **na** is controlled by **bin**, and the modal **kaba di** is controlled by **na**. Notice how, as a result, the difference between aspectual auxiliaries and Ad-verbs, on the one hand, and modals, on the other, further reduces to semantics. The fact that the former are excluded from certain constructions which admit the latter (see above) may thus be seen as a correlate of the differential semantic autonomy (vis-a-vis the controlled VP) of the concepts expressed by the two categories. I will continue to use the feature [MODAL] in order to encode this difference. The subject will be broached again when we come to the study of embedding.

Finally, the possibility of a non finite **na bin** sequence naturally follows from the preceding analysis. Example (69) illustrates this possibility:

(69) I ta pensadu kuma riunyon ma garandi di OUA dibi na bin
 it A be-thought that meeting more big of AUO must A BIN
 fasidu i ka na tarda. (RB)
 be-made it NEG A be-late
 'It is thought that a bigger meeting of the AUO should be convened soon.'

This is a sentence uttered by an announcer during a news bulletin and, as such, its correctness with respect to central Kriyol may be debated. See, e.g., **dibi** without **di** which looks very much like a calque from Portuguese *deve ser convida*. (In fact, what announcers do is read aloud Portuguese dispatches which they simultaneously translate into Kriyol.) Nevertheless, the use of, obviously non finite, **na bin** appears as a quite Kriyol way of expressing something like a prospective-successive infinitive. To put it more accurately (perhaps), it shows the need on the part of a Kriyol speaker to encode these categories, even though they receive no expression in the Portuguese sequence he is translating.

Before concluding this section, I would like to say a few words about the origin of **bin**. Indeed, its intimate connexion with a directional verb meaning 'to come' is obviously not fortuitous. A whole literature is devoted to the relationships of spatial with temporal expressions, a subject which evidently exceeds what can be expertly treated here. Let me only remind the reader that associating posteriority with the meaning 'to come' is not something all that exotic, as witnessed by such expressions as English *I have come to think that...*, or French *J'en suis venu à penser que...*, or Portuguese *Vim a saber dessas coisas muito tarde* 'I finally knew about those things very late' (Cunha & Cintra 1987:395). More interesting for the present study is the fact that **bin** is one of the soundest proofs of the hypothesis that conflation, i.e. chance encounter of phonetically similar forms with compatible semantics, is a crucial factor in the building of creole grammars (see Kihm 1989). Indeed, all surrounding Atlantic languages, viz. Manjaku, Mankanya, Papel, Balanta, and Dyola, possess an item whose form is **bi**, **bin**, or **ben**, and whose meanings are identical to those of Kriyol **bin** (see Kihm 1989 for examples and references). I do not take this as implying that the Kriyol item was borrowed *stricto sensu* from these languages, since it obviously also derives from Portuguese *vem* 's/he/it comes' through regular phonological processes. Rather, I see here a very clear case of conflation whereby Kriyol grammar completed its stocks of syntactic and semantic categories, if I may use so shameless a metaphor, by simultaneously drawing on its lexifier language and its substrate/adstrate.

3.8.2. *Ba and the non-specific future*

The following examples give an idea of what is here intended by the label 'non-specific future':

- (70) Na farmasya di tabanka i na ba ta gwardadu mesinyus, la ku
 in dispensary of village it A BA A be-kept medicines there that
 dwentis e na ba ta tratadu. (GM)
 patients they A BA A be-treated
 'In the village dispensary medicines will be kept and the patients will
 be treated there.'
- (71) Kunformu no na ba ta skribi l asin ku no na ba ta minjorya l. (B)
 according we A BA A write it so that we A BA A improve it
 'According to how we shall write it (Kriyol), we shall improve it.'

Both sentences are programmatic in character, i.e. they refer to events or states of affairs that will continuously or repeatedly be the case in an extended future which either starts from now on, or will begin when some circumstances are met. This complex meaning thus appears to be the symmetrical of that denoted by **na bin**, insofar as the latter can be metaphorically depicted as a zooming in on

some future point, whereas the former is rather like using a wide-angle lens to open up a panorama. And it is expressed by the equally complex sequence of the specific imperfective auxiliary **na**, followed by a morpheme **ba**, followed by the non specific imperfective auxiliary **ta**, followed by a VP. The association of that form with that meaning is a stable one and so deserves especial attention. I will first examine the central, and as yet unknown, member of the construction, viz. **ba**.

Naturally, this item has nothing to do with the homophonous Past marker. It is a reduced form of the verb **bay** 'to go', the meaning of which is interestingly also the symmetrical of **bin** 'to come'. As far as I could ascertain, the reduced form is not used when **bay** has its full meaning of 'to go (to a place)' or 'to go away, leave', i.e. when it takes either an NP [+LOC] complement or no complement at all (see chapter 2 for the argument structure of directional verbs). It is almost always used, in contrast, when **bay** takes a VP complement and means 'to go and...' as in the following example which illustrates both uses of the verb:

- (72) I bay matu i ba panya pirkitu bonitu. (I)
 he go bush he go catch parrot nice
 'He went to the bush and caught a nice parrot.'

The reduced form is also mandatory in a construction which is closely associated with the one we are studying:

- (73) Banyas gosi ta misti ba ta bibi manera ku omi ta bibi. (HGCS)
 girls now A want BA A drink manner that man A drink
 'Girls nowadays want to drink like men do.'
 (74) Ali n tisi u žurnal pa bu bin ba ta ley. (FJGK)
 here I bring you paper for you BIN BA A read
 'Here, I brought you the paper for you to read.'

The first of these sentences should be contrasted with a simpler utterance like **i misti bibi yagu** 'She wants to drink some water'. Here, reference is made to one specific instance of drinking something. Such a unique reference is precisely what is not implied by (73) where **ba ta** is used to denote two meanings which may be glossed as 'from now on' and 'habitually' respectively. The modification of **misti** by **ta** (see above) and the fact that **bibi** has no overt object (and an implied object which is definitely not water) also contribute to the overall interpretation. Similarly, (74) conveys the meaning that I brought you the paper, not so much for you to read it through right now, but rather so as to provide you with reading material that you can peruse as long as and when (as implied by **bin**) you wish.²⁶

Examples (70-71) and (73-74) thus share a basic meaning which can be informally described as 'from a reference time that is either now or posterior to now, and then during an indefinite interval', and this meaning is contributed by the complex **ba ta**, i.e. by the meaning 'go and' temporally interpreted plus the non

specific imperfective modification of the complement VP. With embedded clauses, be they finite or non finite,²⁷ the location of the starting point is indicated or implied by the controlling predicate which thus provides the reference time. In matrix clauses, on the other hand, **na** is regularly used in order to anchor the starting point in speech time. It may be dispensed with, however, provided some element in the utterance fixes the summit of the forward-opening angle to which the denotation of **ba ta** may be compared, as in the following example:

- (75) Ora ku n kumsa preparason n ba ta toma tris sakus di liti
 time that I begin training I BA A take three bags of milk
 blufu pur dia. (FJGK)
 uncircumcised by day
 'When I start training, I'll drink three bags of full milk a day.'

The question of the inner structure of the sequence **ba ta** is thus posed. Could we go as far as to argue that **ba ta** is actually one compounded lexical head? One piece of evidence for this analysis is that, in native texts, **ba ta** is often spelt with a hyphen, **ba-ta**, or in one word, **bata**.²⁸ Insofar as spontaneous spellings reflect the native speakers' *Sprachgefühl*, this may be a revealing fact, although I am not ready to build too much on it. I will therefore stick to a conservative position and analyse **ba ta** as I did **na bin**, i.e. as two lexical heads, with **ba** modifying the VP headed by **ta**. There is no question, on the other hand, that the **na** that may dominate **ba ta** must be counted as a separate head.²⁹

3.8.3. A semantic analysis of the tense auxiliaries

As already suggested, it would be interesting, indeed crucial, to determine why the aspectual auxiliaries and the Ad-verbs are ordered the way they are in any given construction. Recall that we decided against having LP rules taking care of this issue, as it seems much more reasonable to view it as a semantic matter. Couldn't it be, then, that the relative ordering of the elements that constitute the tense expressions built on the tense auxiliaries **bin** and **ba** somehow reflect the logical make-up of these expressions?

The central factor, I think, is the intrinsic semantics of the tense auxiliaries themselves. I compared **bin** and **ba** to two angles, in the photographic sense of the term, forward-closing and forward-opening respectively, as in the following diagrams:

BIN → BA —<

I will now try and formalize this observation somewhat. Obviously, the semantics of tense auxiliaries **bin** and **ba** cannot be divorced from the meaning of the full verbs **bin** and **ba**, viz. 'come' and 'go'. We may thus assume two basic concepts,

COME and GO, which can be spatially or temporally interpreted. Let us analyse the temporal interpretation of COME as a function from an interval I to a time t (see McCawley 1981 for the formalism), just as spatial COME may be analysed as a function from a line to a point. A sentence like **Jon bin fasi kila** ‘Then John did that’ will thus receive the following (tense-)logical structure:

(76) $[\exists I, \lambda t:F(t, I)]$ (Jon fasi kila)

If $I = \{t_1, \dots, t_n\}$, then $F(t, I)$ says that t , the time at which ‘John do it’ is true, follows t_n , the last of the series of times that make up the interval (i.e. t is future – F – with respect to I). Notice that (76) never specifies the location of the interval relative to present or speech time. This is as it should be: As an independent utterance, **Jon bin fasi kila** is interpreted as it is, viz. as accomplished and preceding present time, simply by dint of its being a finite S , i.e. of being an expression of semantic type $\langle s, t \rangle$ which assigns a truth value to a certain world. Were it an embedded sentence, its time reference would be interpreted relative to that of the matrix. In order to specify that the interval following which (John do that) is true is posterior to present time, we have to alter (76) to

(77) $[\exists I:F(I, NOW), \lambda t:F(t, I)]$ (Jon fasi kila)

That is, we have to predicate of the interval the fact that it follows ‘now’ (NOW). A third possibility is for I to be coterminous with N , as in (78):

(78) $[\exists I:I=NOW), \lambda t:F(t, I)]$ (Jon fasi kila)

This can be taken as the logical formula for the prospective interpretation of **Jon na fasi kila** ‘John will do that’ (vs. ‘John is doing that’). Indeed, what (78) says is that ‘John do that’ is true at a time t following the last time t_n of an interval which includes the present time. ($I=NOW$ would be more accurately stated as $NOW \leq I$ — NOW is a proper subset of I — since $I=NOW$ ultimately means something like ‘extended present’.) It thus appears that specifying I relative to NOW leads to the insertion of **na** in the VP as a constant syntactic correlate. **Bin**, for its part, appears as the lexical expression of the logical relation $F(t, I)$, except when I is equated with NOW . This means that, in order for the semantics of **bin** to be met, not only must t — the time at which the proposition is true — follow a certain interval, but the interval must itself follow a certain period of time.³⁰ Either this period is ‘now’ and is explicitly mentioned in the logical formula as in (77), or it is not mentioned as in (76), and it is then understood by default as being some period preceding the interval which precedes t — t then receiving the default interpretation of anteceding NOW . In (78), in contrast, it is not stated, implicitly or explicitly, that I relevantly follows a period of time, since it is equated with the present, so the semantics of **bin** is not satisfied. Syntactically, the $F(I, NOW)$

interpretation in (77) is obtained by having **na** be prospectively interpreted as a modification of **bin**, not of the VP expressing the proposition. The correlation between the logical formula and the syntactic construction is thus clarified.

Whereas **bin** has just been analysed as a function from an interval to a time, **ba** may conversely be analysed as a function from a time to an interval. That is, (76) should be paralleled with:

(79) $[\exists t, \lambda I:F(I, t)] (P)$

which says that proposition P is true during an interval $\{t_1, \dots, t_n\}$ such that t_1 , the first moment of the interval, follows some time t. Being true during an interval, i.e. being habitually or iteratively true, is what is expressed by the non-specific imperfective auxiliary **ta** bearing on the VP that expresses P. **Ba** expresses the fact that the interval relevantly follows some point in time. The relative ordering of the Ad-verb and the aspectual auxiliary is thus accounted for. The location of the 'starting point', in turn, may be implicitly fixed relative to some other proposition as in (75), or it may be fixed relative to the present. Actually, this means equating it with 'now':

(80) $[\exists t:(t=\text{NOW}), \lambda I:F(I, t)] (P)$

Again, prospective **na** modifying **ba** expresses this temporal relationship.

Comparing (76) with (79) thus shows in what sense both tense expressions are indeed each other's converse and are related to the basic concepts COME and GO, i.e. to the notions of reaching a point having passed through a sequence of points, or of passing through a sequence of points having departed from a point. Note further that COME and GO have somewhat different implications as to their end results. COME normally implies that the goal was reached, whereas GO does not (compare ?'I came to town yesterday, but I was held up on the way' with 'I went to town yesterday, but...') The reality effect of **bin** commented on earlier can thus be explained as a consequence of the basic meaning of the item. In contrast, (**na**) **ba ta** presents no such effect.

3.9. Questions of scope

As suggested earlier, Tense and Aspect, wherever they are expressed in a sentence, have scope over the whole proposition corresponding to that sentence. This is obvious for Tense, but no less so for Aspect. Recall, for instance, examples (19) and (20) which show how Aspect determines the truth value of a proposition. In syntactic terms, we therefore have to say that the potency of Tense and Aspect takes effect at the VP and S levels, whereas the semantic translation of the same

phenomenon is that T and A ought to be considered operators on Ss. Let us examine Aspect first.

An attractive aspect of the present analysis of the semantics of Aspect in Kriyol is that it makes such 'raising' especially easy to account for. Indeed, Aspect values have been equated with the composition of (a) the default interpretation of finiteness; (b) the inherent meanings of the aspect verbs *na* and *ta* for values other than mere Perfective. Factor (a) is active at the S level by definition, and factor (b) pertains to the VO level, i.e. to the lexical head of S. Nothing special has to be done in the syntax, therefore, to ensure proper percolation of the Aspect values up to the highest sentential level, and this is as it should be.

How shall we represent Aspect scope in the semantics? We might simply make up four new operators, let's call them PF, IPF, SP and NSP, and prefix them to sentence translations. Handy, but not very illuminating. I think a better solution can be found. Clearly, the contrast perfective vs. imperfective as well as that between both imperfectives has to do with the present truth or falsity of the expressed event or state of affairs. I propose that it also has to do with whether the said event or state of affairs is self-contained within one world, i.e. inaccessible from any other world, or is accessible from other, possibly all worlds. Non-specific imperfective is thus analysed as not self-contained, whereas specific imperfective is self-contained. Perfective, on the other hand, has no intrinsic value, being a default interpretation of finiteness. What we need, then, is a formal definition of finiteness as a sentential operator, FIN. (Such a view of finiteness is, I think, legitimate for Kriyol and similar languages; I am not taking any universalist stand on this matter). Let me apply to FIN the definition given to P (Past) in Dowty and al. (1981:115):

- (81) If ϕ is a formula, then $[[\text{FIN}\phi]]^{M,i,g} = 1$ iff there is some i' in I such that $i' < i$ and $[[\phi]]^{M,i',g} = 1$; otherwise $[[\text{FIN}\phi]]^{M,i,g} = 0$

That is to say, a finite formula or sentence is true relative to a model M, a time i , and an assignment of value to the variables g , if there is some time i' anterior to i when the formula is true. Note that (81) never specifies that i' should be the *last* time before i when ϕ has been true.³¹ Suppose i is identified with the present time (i.e. the cooccurrence of reference and speech times, RS). Then (81) may well be consonant with a situation where ϕ *began* to be true at some time previous to now, and is still true, which, to put it more rigorously, means that the formula is true insofar as its truth value equals 1 at any moment i'_i of the interval $\{i', i'+1, \dots, i'_i, \dots, i' = i = \text{RS}\}_I$. An example is *n sibi* 'I know', that is 'I knew and still know'. It is also consonant with the distinct situation where ϕ was true and is no longer, i.e. in the restrictive interpretation of (81), where i' is unique. As already

mentioned, the alternative is a function of the inherent semantics of the verb or predicative item, with event verbs on one side, non-event verbs (including the aspectual auxiliaries **na** and **ta**) and adjectival and noun predicates on the other side. It is therefore quite easy to deduce the proper value of a Kriyol finite sentence from the functional application of FIN to an S headed by an item of a given type, provided we modify (81) in such a way as to specify that the time coordinate of the world $\{M, i, g\}$ must be fixed to RS time. Abbreviating somewhat, this gives us (81'):

- (81') If \emptyset is a formula, then $[[\text{FIN}\emptyset]]^{\text{RS}} = 1$ iff there is some i' in I such that $i' < \text{RS}$ and $[[\emptyset]]^{\text{M}, i', g} = 1$; otherwise $[[\text{FIN}\emptyset]]^{\text{RS}} = 0$

Interworld accessibility does not enter this definition because it is necessarily included in the semantic qualification of the predicate as denoting an event (self-contained by definition unless otherwise specified) or a non-event, i.e. some kind of enduring state.

Let me now define another operator, called NOW:

- (82) If \emptyset is a formula, then $[[\text{NOW}\emptyset]]^{\text{M}, i, g} = 1$ iff there is some i' in I such that $i' < i$ and $i < i'$ and $[[\emptyset]]^{\text{M}, i', g} = 1$; otherwise $[[\text{NOW}\emptyset]]^{\text{M}, i, g} = 0$.

NB: Unless otherwise specified, I includes RS.

That is, a formula is now true relative to a time i if there is a time i' that is neither posterior nor anterior to i when the formula is true. Two remarks are in order. First, NOW is defined on an interval which must be an extension of 'real' now, i.e. RS time, unless some functor (viz. Past — see below) moves the whole thing to another frame. Secondly, (82), like (81'), does not say that i' should be the only time of its sort. Now, however, the alternative is no longer an obligatory consequence of the semantic type of the predicate. With some principled exceptions, both interpretations may be instantiated on every predicate. We must therefore define accessibility from different times/worlds in terms of the existence or not of various times at which the formula is true. Self-contained and accessible times will then translate as in (83) and (84) respectively (read L as 'necessarily', and P as 'possibly'):

- (83) If \emptyset is a formula and $[[\emptyset]]^{\text{M}, i, g} = 1$ for some i in I, then $[[\text{L}\emptyset]]^{\text{M}, i', g} = 0$ for all $i' \neq i$
 (84) If \emptyset is a formula and $[[\emptyset]]^{\text{M}, i, g} = 1$ for some i in I, then $[[\text{P}\emptyset]]^{\text{M}, i', g} = 1$ for some $i' \neq i$

According to (83) a formula is self-contained when it is true in a world and false in all others; it is accessible, according to (84) when it is true in a world, and there are some other worlds where it is also true. A sentence such as **Ze ta cami** 'Joe boozes/is a boozer' thus translates to $[[\text{FIN}(\text{NOW}(\text{cami}'(\text{Ze}^*)))]]^i = 1 \ \& \ \exists i' \neq i,$

$[[\text{FIN}(\text{NOW}(\text{cami}'(\text{Ze}^*)))]^i]^1 = 1$, which abbreviates to $[[\text{FIN}(\text{NOW}(\text{cami}'(\text{Ze}^*)))]^{(i_1, \dots, i_n)}] = 1$, with $\{i_1, \dots, i_n\}$ a subset of I ($RS \leq I$), possibly equal to I ('all' being the limiting case of the existential quantifier). For full generality, I will write

$$(85) \quad [[\text{FIN}(\text{NOW}(\text{cami}'(\text{Ze}^*)))]^{(w_1, \dots, w_n)}] = 1$$

with $w =$ 'world' (or 'time', see below). Put back into plain words, (85) says that $(\text{cami}'(\text{Ze}^*))$ is a state of affairs that came into existence at some time previous to RS time (FIN), and that remains true over an interval whose beginning coincides with the indefinite time implied by FIN , and whose end is also indefinite, but necessarily posterior to RS since RS is part of the interval. FIN can therefore be considered an actualization operator ensuring that the proposition on which it bears has reality (is an autonomous predication about something which got a place in the or some world). It follows that $[[\text{NOW}(\emptyset)]^{(w_1, \dots, w_n)}] = 1$ is indeed the meaning of **ta**, or an approximation to this meaning. Note that the fact that \emptyset ranges over an array of worlds as a consequence of applying the operator $\text{NOW}^{(w_1, \dots, w_n)}$ entails that the proposition can only be interpreted intensionally. In other words, (85) does not imply that $(\text{cami}'(\text{Ze}^*))$ is factually (extensionally) true in any specific world in the array, only that its intension is verified in all worlds in the array. Indeed, as already explained, I'm not saying I'm presently drinking wine when I say **n ta bibi binyu**, although the proposition is obviously true as I am uttering it. By the same token, **lubu ta branku** does not express anything about any particular hyena now in sight. In the last case, we are clearly dealing with a 'relation in intension' of type $\langle s, \langle \langle s, \langle e, t \rangle \rangle, \langle \langle e, t \rangle, t \rangle \rangle$ between a set of individuals $\langle \langle e, t \rangle, t \rangle$ and a property of individuals $\langle s, \langle e, t \rangle \rangle$.

Note that some precaution has obviously to be taken before deciding whether the worlds which **ta** expressions have access to are indeed different possible worlds or rather different times of the same world. For instance, it seems counter-intuitive to claim that **Jon ta bay skola** 'John goes to school' (i.e. 'is a school-boy') is true in several or all possible worlds. What we want it to mean instead is the truth of the proposition that John has been going, is still going, and will probably continue for some time going to school, in the actual world. On the other hand, **lubu ta branku** does indeed seem to assert that in no possible world could hyenas be anything but white, i.e. $\forall xL[\text{lubu}(x) \rightarrow \text{branku}(x)]$, giving L (*necessarily*) the strongest interpretation of 'in all possible worlds, always'. Again, we see that the final meaning depends on the character of the parts. This won't change the definition of the aspect verb, however, provided we are willing to consider the functional equivalence of worlds and times as components of indices in Montague's sense.³²

Conversely, applying the same abbreviations as above, **Ze na camí** 'Joe is boozing/will booze' translates to:

$$(86) \quad [[\text{FIN} (\text{NOW} (\text{cami}'(\text{Ze}^*)))]]^{[w]} = 1$$

That is, (**camí'**(**Ze***)) is a state of affairs that came into being at some time (immediately) anterior to RS and is true in an interval coterminous with RS. Note how (82), the definition of NOW, nicely covers both (85) and (86), coterminality being the limiting case of inclusion, when the set of possible worlds has only one member.

Again, (86) may be viewed as **na**'s meaning. As for its Prospective meaning — in my opinion, a situationally induced effect which does not lead to any modification of (86) — I refer the reader to Goldsmith and Woisetschlaeger (1982), whose analysis of the English progressive readily extends to Kriyol.

Notice also that the world vs. time problem does not arise with **na**, since it effectively reduces the universe to one world and one time. We already saw how this explains the 'becoming' meaning it imparts to adjective predicates.

There remains a problem, though, which is that the preceding considerations apply only to main verbs, whereas we know cases where controlled verbs do bear an aspect value, as in **mininu kumsa ta cora** 'The child began to cry', or **n puidi ta bin fasi I** 'I may do it'. Such cases crucially pose the problem of what is a finite sentence, since finite sentences are often equated with tensed sentences and conversely for non finite sentences.³³ It would follow from this assimilation that **ta cora** and **ta bin fasi I** are finite sentences although they do not have a subject and are clearly arguments in a control construction. This is a difficult conclusion to accept.

We do not have to accept it, however, if only because the identification of finiteness with the presence of Tense and Aspect is mistaken. There are countless examples across languages showing that infinitives can be, indeed always are tensed and aspectualized (see, e.g., Russian). What is crucial, on the other hand, to define an expression as finite is whether it includes a subject, because only then can it give rise to a terminated translation of type VP'(x) — see the subject-predicate rule in Montague (1974). I therefore propose that FCR (39), repeated below, should be strengthened to a biconditional as in (87):

$$(39) \quad \text{FCR: } [+ \text{SUBJ}] \Rightarrow [+ \text{FIN}]$$

$$(87) \quad \text{FCR: } [+ \text{SUBJ}] \Leftrightarrow [+ \text{FIN}]$$

That is, a Kriyol expression with a verbal head will count as finite, and hence possibly receive the default aspect value attached to [+FIN], only if it includes an autonomous, i.e. overt, subject — only if it is a sentence, in other words.³⁴ So **ta**

cora and **ta bin fasi I** are not sentences and are not finite. But nothing in what has been said so far prevents them from accepting Tense and Aspect values having scope over them only, if there is a semantic justification for it.

Interestingly, such a view of finiteness allows us to understand something that came up earlier somewhat as a mystery, viz. why is **kumsa** interpreted as an Adverb when it dominates a bare verb (**i kumsa say** 'S/he has just gone out'), and as a modal when it dominates an aspectualized VP (**mininu kumsa ta cora**). To be complete, I should add that verbs denoting a non instantaneous event (i.e. unlike **say** 'go out') are a cause for ambiguity, so that, e.g., **i kumsa kume** means either 'S/he has just eaten' or 'S/he began to eat'. The reason, I think, is that this sentence can be semantically constructed in two ways:

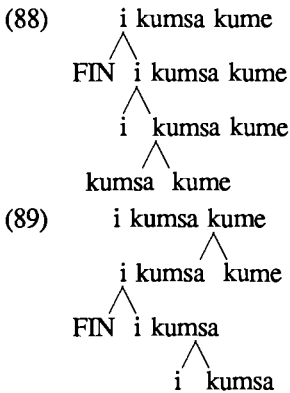

In (88), [FIN] has scope over the sequence **kumsa kume** which it treats as one VP. In (89), in contrast, it has scope only over **kumsa** and **kume** has no aspectual specification. It merely denotes the property of 'eating'. Let us assume that **kumsa**'s only meaning is 'begin'. Then (88) corresponds to a meaning which may be glossed as 'S/he began having eaten', i.e. *s/he* is at the beginning of the interval where *s/he has eaten* is true. Hence, *s/he* has just eaten.³⁵ In contrast, (89) simply means 'S/he began to eat'. Since there is no such alternative when the lower verb bears its own marking, and **mininu kumsa ta cora** can only be constructed as in (89), no semantic ambiguity ensues either. With an 'instantaneous' event verb like **say**, on the other hand, the 'begin' interpretation seems rather improbable, although not quite impossible (e.g. **i kumsa ba na say oca...** 'S/he had begun going out when...').

It should be emphasized that such a view of things is fully consonant with the conception of Aspect marking developed in this book. Indeed, the analysis tree (88) applies *in toto* to such banal constructions as **n na kume** 'I'm eating', where

the meaning of the aspectual auxiliary spreads over the whole VP (actually the whole sentence, as explained above), and the modified verb is nevertheless non finite insofar as it does not head an autonomous proposition. Compare this situation with expressions built around verbs like **jumna** (see (24) and the discussion there) or **pasa** ‘come to’ as in the following example:

- (90) Mininus pasa e obi son kriyol. (I)
 children come-to they understand only Kriyol
 ‘The children came to a point where they understood only Kriyol.’

A simpler translation of (90) might also be ‘In the end, the children...’. Here, both the Ad-verb and the verb are finite as they both head a proposition, although obviously the first one would be incomplete without the second. It would be well to characterize such constructions as (24) and (90) a bit more precisely, contrasting them with the more commonplace control constructions. Since they involve, I think, a long distance dependency—given the obligatory coreference of the subject of the Ad-verb and that of the verb—I will come back to them in Chapter 5.³⁶

I conclude this section and the chapter with a few more words about the semantics of **ba**, the Past adverb. Dowty et al.’s definition of the operator P (p. 115) fits it quite well, *modulo* a small adjustment:

- (91) If \emptyset is a formula, then $[[P\emptyset]]^{M,i,g} = 1$ iff there is some i'' and some i' in I such that $i'' < i' < i$ and $[[\emptyset]]^{M,i'',g} = 1$; otherwise $[[P\emptyset]]^{M,i,g} = 0$

The formulation of (91) is identical to that of Dowty et al.’s SEM B.11. (p. 115), except for encoding the pluperfect character of **ba**. **Kasisa ta bay ba sinema** ‘Ghosts used to go to the cinema’ thus translates to (92):

- (92) $[[[\text{FIN} (P (\text{NOW} (\text{bay-sinema}'(\wedge\text{kasisa}))))]]^{w_i \dots w_n}]$

corresponding to the analysis tree (93):

- (93)
- ```

 kasisa ta bay ba sinema
 / \
 FIN kasisa ta bay ba sinema
 / \
 P kasisa ta bay sinema
 / \
 ta' kasisa bay sinema
 / \
 kasisa bay sinema
 / \
 bay sinema

```

In (93), scopes are represented: FIN has scope over the whole sentence; P has scope over the aspectualized sentence; and **ta'** has scope over the bare predication (go-to-cinema'( $\wedge$ ghosts)).





## Chapter 4

### The noun phrase

#### 4.1. Introduction

In the preceding chapters, noun phrases were only dealt with *qua* arguments of predicates, which means they were taken as, so to speak, ‘black boxes’. Now, we will open the boxes and penetrate into the inner structure of Kriyol NPs. The chapter is organized as follows, proceeding outward from the innermost elements to the expansions.

First we examine the head of the phrase, i.e. (common) nouns, whose compositional and derivational processes are described. Inflectional morphology on nouns in Kriyol is limited to plural formation. As this is a formally simple, but semantically intricate operation, I will devote some space to it. One level up, we will deal next with those elements which may be viewed as occupying the specifier or determiner position, viz. articles (actually one item in Kriyol), demonstratives, numerals, quantifiers, and possessives. One more expansion of the head will lead us to NPs modified by adjective phrases, and then to coordinated NPs.

We will then consider pronouns. We will successively review personal pronouns, with particular emphasis on the ‘neutral’ third person pronoun *i*, reflexive and reciprocal expressions, and possessive pronouns. Of course, analysing these elements will force us to discuss the syntactic positions in which NPs occur, since questions of scope and of ‘binding’ will have to be considered.

Finally, relative clauses, i.e. finite propositions modifying head nouns, will be studied at length.

#### 4.2. Composition and derivation

As already mentioned, there is no general formal distinction in Kriyol between nouns, proper or common, and other kinds of grammatical objects.<sup>1</sup> Nouns do differ phonologically from verbs insofar as the latter are stressed on the last, open

syllable, whereas the former are stressed on the penultimate when the ultimate is open (see Chapter 1). However this distinction is not always maintained, so there is nothing in the phonology to tell us that, e.g., **n bibi** ['mbibi] 'I drank' is not a noun like **nbera** ['mbera] '(river) bank'. Only combinatorics and a few processes specific to one or the other category may be relied on to always draw a clear line independently of the meaning of the forms. Composition and derivation belong to these processes. Indeed, only nouns can be made up from several elements and still be interpreted as one lexeme. Verbs do not have this property. Complex predicates never reduce to one lexeme, as we saw and will see again later on. Derivation is also quite specific since the set of derivational morphemes for nouns is entirely disjoint from the same set for verbs.

The head features attributable to Kriyol nouns are the usual ones (see Gazdar et al. 1985:23), except for the conspicuous absence of Gender; even third person pronouns do not distinguish it. It follows from this that the /-u/ and /-a/ endings which, in Portuguese, correlate fairly accurately with the masculine or the feminine gender of the nouns bearing them, and which may thus be analysed as separate morphemes, are inherently part of the stem in Kriyol. Simple nouns such as **kasa** 'house' or **binyu** 'wine' are therefore no more analysable into smaller elements than are simple verbs. Case is overtly expressed in pronouns only.

#### 4.2.1. *Composition*

Composition of various elements to produce a noun is a relatively free process in Kriyol. It seems to have always been used as a means of expanding the vocabulary. The number of elements which may be put together seems to be limited to two — at least I never encountered longer sequences — not counting linking prepositions and sentences used as designators of entities.

Compound nouns in Kriyol belong to different categories according to the way they are made up. The elementary case may be considered to be that of two apposed nouns as in the following examples:

- (1) **alma-byafada** 'marabout' (lit. 'soul Byafada'); **bicu-kabelu** 'caterpillar' (lit. 'worm hair'); **binyu kaju** 'cajou wine'; **kacu-martel** 'ibis' (lit. bird hammer'); **macu-minjer** 'homosexual' (lit. 'man woman')

Compounds of this type with **macu** 'male' or **femya** 'female' as a second term provide a ready means of palliating the absence of grammatically marked gender (e.g. **yermon macu** 'brother' vs. **yermon femya** 'sister' vs. **yermon** 'sibling'; **gatu macu** 'tomcat' vs. **gatu femya** 'she-cat'; and so forth).<sup>2</sup>

Although I would consider such compounds to have flat structures as in (2):

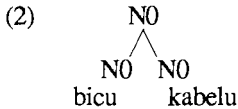

they may be said to be semantically left-headed, insofar as the eponymous or superordered term always comes first when there is one: a **bicu-kabelu** is a kind of worm — in folk-zoology at least — which looks like a bunch of hair; a **kacu-martel** is a kind of bird whose head is hammer-shaped; and so forth. A **marabout**, on the other hand, is certainly not a kind of soul (Byafada is an ethnic name). Similarly, **macu-minjer** does not describe homosexuals as men who are women or women who are men, but as human beings who are supposedly both man and woman. Such compounds are therefore best analysed as lacking a head altogether.

Another type of compounds is necessarily headed, however. It is the kind that is made up of a noun and a complement to this noun:

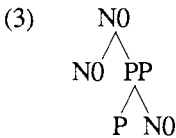

The preposition is always **di** ‘of’:

- (4) **biku-di-mama** ‘nipple’ (lit. ‘beak of breast’); **kuku-di-obu** ‘testicle’ (lit. ‘cocoanut of egg’); **pididur-di-sumola** ‘beggar’ (lit. ‘asker of alms’)

A variant of this type is where the complement is a verb as in **banku-di-rola** ‘washboard’ (lit. ‘board of rolling’); **dedu-di-cudi** ‘forefinger’ (lit. ‘finger of pointing’); **paja-di-kubri** ‘thatch’ (lit. ‘grass of covering’). Note that the verb may have an object, as in **korda-di-sibi-palmera** ‘climbing rope’ (lit. ‘rope of climbing palm-trees’), which shows it to be a non finite rather than a nominalized verb, so that (3) should be modified to (4) (see Chapter 5 for this use of **di**):

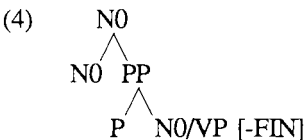

A verb and its object may be fossilized into a compound noun:

- (5) **abri-bunda** ‘enema’ (lit. ‘open anus’); **bana-moska** ‘fly whisk’ (lit. ‘wave-away flies’); **gwarda-cuba** ‘umbrella’ (lit. ‘keep rain’);<sup>3</sup> **labarému** ‘tip’ (lit. ‘wash oar’); **panga-bariga** ‘diarrhoea’ (lit. ‘hurt belly’)

Fossilization seems indeed to be the right image, since the VP as a whole was transmuted into a noun constituting a single lexeme. The proper structures for items as in (5) must then be something like (6):

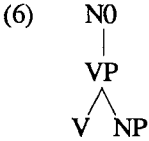

Finally, one finds rarer cases of noun-adjective compounds — e.g. **bagera-brabu** ‘wasp’ (lit. ‘bee wild’); **iran-segu** ‘python’ (lit. ‘spirit blind’); and so forth — and of sentences used as nouns, as e.g. **si-Dews-da-n-minjer** ‘kind of sparrow’ (lit. ‘if God gives me wife’). I know of only two subject-verb compounds, viz. **sol-mansi** ‘dawn’ (lit. ‘sun dawns’) and **sol-noti** ‘twilight’ (lit. ‘sun darkens’), which does not mean there are not others.

Note that a compound may itself provide the first or second term of another compound, as in **gwarda-cuba-di-sapu** ‘toadstool’ (lit. ‘keep-rain (‘umbrella’) -of-toad’), so that the binarity of noun-noun compounds is not jeopardized.

It should be mentioned that all compound types exemplified above exist in the source language, even though a large majority of items appear to be specific to Kriyol. That is to say, Kriyol inherited the types, but made up the tokens.

On the other hand, those same types also seem to exist in the substrate languages, although I was able to make but a cursory survey. Noun-noun and verb-noun compounds are amply documented in Atlantic as well as in Mandinka. Here are two examples from Manjaku (Buis 1990): *aook anin* /cousin mother/ ‘cousin on the mother’s side’; *upafi been* /putting head/ ‘headrest’; and two from Mandinka (Rowlands 1959): *jàtakulu* /lion (*jàta*) skin (*kùlu*)/ ‘lionskin’; *màdani-kati* /rice cut/ ‘rice cutting’. As can be seen, Manjaku like Kriyol and a majority of Atlantic languages is left-headed, whereas Mandinka is right-headed. Whatever the ultimate pattern of influences, no conflict could thus arise between the contributors to Kriyol, except for the ordering difference just mentioned.

As far as meaning is concerned, a number of compounds are fairly transparent, given a knowledge of the world whose particulars may range from common (e.g. **bicu-kabelu** ‘caterpillar’) to quite specialized (e.g. **iran-segu** ‘python’). Others, such as **laba-remu** ‘tip’ are non componential, hence semantically opaque.

#### 4.2.2. Derivation

But for two exceptions, suffixation is the only morphological process deriving nouns in Kriyol. I will deal with the exceptions first. One is the item **ba-** (**ban-** in Ziguinchor) which prefixes to people's names to form a 'committative' such as, e.g., **ba-Pedru** 'Peter and his folks'.<sup>4</sup> Committatives convey the specific meaning that the individual referred to is indeed accompanied by persons related to him/her, and that they are acting as a group in the relevant situation. It would not do, for instance, to say **n kungsi ba-Pedru** meaning that I know Peter and his family, or friends, etc. Only 'situated' utterances such as **ba-Pedru bin pa mi awonti** 'Peter and his folks came visit me yesterday' are acceptable. The other exceptional item is **gan-** which prefixes to personal or ethnic names to designate a human habitat: **gan-byafada** 'Byafada-land', **gan-Mamadu** 'Mamadu's place'. While **ba-** is still quite alive in Bissau, **gan-** seems to me to be much less used and by and large limited to lexicalized designations. The former is obviously a borrowing of the Class 2 prefix /ba-/ denoting plural humans which is found in a number of surrounding Atlantic languages, particularly Manjaku, Balanta, and Dyola. The origin of **gan-** is unknown to me.

As far as derivative suffixation is concerned, two cases must be distinguished. First, there are those derived nouns which were taken en bloc from Portuguese, so that the suffix they include never became productive in Kriyol proper. Such are, e.g., **kamaradiya** 'comradeship' (P. *camaradia*) next to **kamarada** 'comrade' (P. *camarada*), as well as such 'modern' items as **organizason** 'organization', **sosyalizmu** 'socialism', and so forth. What I mean by this is that /-iya/ or /-son/ never occur in combinations that do not exist in the source language, so that, for all intent and purposes, **kamaradiya**, **sosyalizmu**, etc. may be considered simplexes in Kriyol.

Things are different, however, with items like **amigundadi** 'friendship', **janbakusindadi** 'witch-doctor's craft', **benenyamenti** 'poisoning', **katiberasku** 'slavery', **klarensa** 'clarity', etc. Here we find nouns which are clearly derivative in the sense that the economy of Kriyol grammar does indeed call for the inclusion of such elements as /-ndadi/, /-menti/, /-asku/, /-ensa/, etc. Although they originate in Portuguese from which they were necessarily taken as bound forms, they were analysed away from those forms and then used as grammatical tools to build Kriyol lexemes that have no equivalent in Portuguese.

The example of /-ndadi/ is especially illustrative. Note first the phonological change which prenasalized the first consonant (compare, e.g., P. *caridade* 'charity'). We may surmise that nasality first came along with Portuguese forms where it belongs to the root, such as *irmandade* 'fraternity', and was then

reanalysed together with the suffix when the latter became autonomized. Which raises the issue of double borrowings insofar as the Portuguese suffix also survives in Kriyol forms where it was obviously not distinguished as such, e.g. **liberdadi** 'liberty, freedom' (P. *liberdade*). As with **kamaradiya** above, such forms are probably best analysed as simplexes in Kriyol (in Portuguese as well, for that matter). Thus, we are not forced to assume two suffixes /-ndadi/ and /-dadi/; rather, there is one suffix /-ndadi/ whose relation to P. /-dade/ is merely historical, and there are underived words whose ending may also be related to the same Portuguese element.

Both items, the Kriyol and the Portuguese, are formally as well as semantically distinct. Prenasalization was already mentioned as a differentiating factor. Note further that /-ndadi/ always follows a vowel, so that in the rare cases where the stem ends in a consonant (i.e. a sonorant — see Introduction) an epenthetic vowel appears as in **janbakusindadi** from **janbakus** 'witch-doctor', a word of possibly Dyola origin.

Semantics is also clearly divergent. Portuguese /-dade/ has a quite vague meaning like its Romance equivalents or English /-(i)ty/. The Kriyol meaning is much more specific and may be glossed as 'abstraction of the set of entities which have all the characters of...', where 'abstraction' is taken in the sense of Dowty et al. (1981) and the entities are primarily human. For example, **janbakusindadi** denotes what is common to and defintory of all **janbakus**, viz. their craft. Likewise, **brankundadi** does not mean 'whiteness' as being the quality of any white object, but as the characterization of all white people ('albitude' might be a more accurate, if pedantic, translation). **Amigundadi** is friendship as a human institution, to be distinguished from the more recent borrowing **amizadi** (P. *amizade*), meaning friendship or love as an interpersonal feeling.

Considering /-ndadi/ to be one element in the lexicon of Kriyol and using Sadock's formalism (1991), I will therefore analyse it as follows:

- (7) ndadi  
 Syntax: nil  
 Morphology: [<sub>N<+></sub> <sub>0></sub> <sub>α</sub> N-0 —]  
 Semantics: abstraction of the human characteristics implied by the meaning of the stem

That is, /-ndadi/ is a suffix which forms nouns from designated nouns or adjectives (i.e. N<+> items) with the semantic effect indicated and plays no role in syntax. Designation through the  $\alpha$  notation is necessary because /-ndadi/ suffixation is not entirely free.<sup>5</sup>

The same analysis applies readily to other suffixes. For instance, /-asku/ as in the example given above or in **burmejasku** 'redness', **brajerasku** 'cleverness', etc., seems almost synonymous with /-ndadi/, except that the abstraction it effectuates has not to do with human characteristics as such: **katiberasku** does not denote the defining qualities of slaves ('slavitude') but the state of affairs brought about by the existence of slaves ('slavery'). /-esa/ is specifically linked to stages in human life as in **bajudesa** 'maidenhead', **mininesa** 'childhood', **bejisa** 'old age' (but see **bonitesa** 'beauty [of a human being]' or **mufunesa** 'unhappiness', which need a little stretch of imagination to be attached to the same domain).

Two suffixes should be set apart as they are used to derive nouns, not from nouns or adjectives, but from verbs. One is /-dur/ meaning 'Agent of the action denoted by the verb', as in **bakyadur** 'shepherd', **benenyadur** 'poisoner', **camidur** 'drunkard' (**cami** 'to booze'), **kanbantadur** 'ferryman', etc.<sup>6</sup> The other is /-menti/ meaning (roughly) 'accomplishment of the action denoted by the verb', as in **benenyamenti** 'poisoning', **lebisimenti** 'mockery', **gardisimenti** 'gratefulness' (**gardisi** 'to thank'), etc.

Finally, one may hesitate as to the proper classification of the diminutive item /-sinyu/ (e.g. **barakasinyu** 'small hut', **minjersinyu** 'little woman', etc.). Like its Portuguese etymon (-*zinho/a*) it differs from ordinary derivative suffixes in being (i) almost entirely productive; (ii) stressed on the first syllable, whereas the noun it attaches to keeps its own, now secondary, stress. This is not enough, however, to consider /-sinyu/ an adjective rather than a suffix inasmuch as, except for stress, nouns with /-sinyu/ behave exactly like ordinary derived nouns, for instance with respect to inflectional suffixation (cf. **minjersinyus** 'little women', not \***minjerissinyu** — see below).

Free derivation means that the stock of derived nouns is potentially open, not that speakers keep forming new items all the time. There is one domain, though, where derivation is to an extent a free game, and that is written poetry. Derived nouns, existent or created on the spot, are often used by poets for their aesthetic effects, a little like *keningar* in old Norse and Anglo-Saxon poetry. This may well continue a tradition of oral poetry, judging by the few verses quoted in Barros (1900).

### 4.3. Inflectional morphology: the plural

Plural marking is indeed the only inflectional morphology there is in Kriyol. It is a vexing problem as it appears at the same time quite simple in its form and quite complicated in its usage. I will begin with the former and then try to throw some light on the intricacies of the latter.



Kriyol stands rather isolated among creole languages in that it did not devise some new way of forming the plural — e.g. by suffixing the 3rd person plural pronoun as in São Tomense and so many other creoles — but simply kept the Portuguese morpheme /-s/. This is suffixed to the stem if it ends in a vowel (e.g. **omis** ‘men’); otherwise an epenthetic vowel appears, which is /i/ in Bissau and /u/ in Ziguinchor (e.g. **minjeris/minjerus** ‘women’).<sup>7</sup> As expected, Portuguese morphophonemics disappeared en route, so we have **salton(s)** ‘toad(s)’ instead of *saltão/saltões*. Recent borrowings are often exceptional, though (e.g. **fiskal/fiskays** or **fiskayš** ‘tax inspector(s)’ as in the source language).

Plural usage is complex because it looks as if Kriyol was equipped with two alternate grammars. One is similar to Portuguese, and it consists of one principle which may be roughly formulated as follows:

Plural Marking Principle I. Use plural morphology on a noun whenever more than one token of the entity it denotes is relevantly present in the world shared by the participants.<sup>8</sup>

It differs from Portuguese (and Manjaku, etc.) grammar insofar as no provision is made for agreement, unless one is willing to accept such vague statements as ‘attributive adjectives may agree in number with the head noun or predicative adjectives with the subject’. What this amounts to is that only the head noun is normally marked for plurality, and that only sporadically or in somehow ‘decreolized’ varieties does one run into examples like the following:

- (8) Sapatus altus ku bonitu sin. (I)  
 shoe+PL high+PL that nice so  
 ‘High-heel shoes that are so nice.’
- (9) Kil mas perigozus bandidus di Italya. (MCDM)  
 that more dangerous+PL gangster+PL of Italy  
 ‘Those more dangerous gangsters from Italy.’

Of course, this is the place for a variable grammar on the model of, e.g., Labov (1968). I can only hope that other scholars, preferably local, will attempt it.

The alternative grammar that may be used is definitely farther from Portuguese and hence (?) may be considered older, more **fundu**. (It is also farther from the Atlantic surrounding languages and closer, or so it seems, to Mandinka.) Here, plural marking is regulated by the following approximate principle:

Plural Marking Principle II. Use plural morphology on a noun whenever more than one token of the entity it denotes is relevantly present in the world shared by the participants, unless the entity is conceived of in non specific terms and/or its cardinality is explicitly indicated by a specialized lexical item.

Agreement is entirely absent in this grammar. The last clause of PMP II means that a noun won't be marked as plural if it is modified by a numeral or a quantifier already implying plurality:

- (10) Dus galu ka ta kanta na un kapwera. (TM)  
 two cock NEG A sing in a chicken-yard  
 'Two cocks won't crow in one yard.'
- (11) Kil omi ten manga di minjer. (I)  
 that man have lot of woman  
 'That man has lots of women.'
- (12) Lingwa propi di no tera n ta fala I tudu. (I)  
 language proper of our country I A speak it all  
 'The languages of our country, I speak them all.'
- (13) N na leba u nunde ku sancu ciw nel. (HGTD)  
 I A take you where that monkey much in+it  
 'I'll take you where monkeys are many.'

The last two examples are interesting in that they show that the modifying quantifier (**tudu**, **ciw**) does not have to be in construction with the head noun (**lingwa**, **sancu**) for the latter not to be redundantly marked as plural. This confirms the semantic nature of the phenomenon. Also note the singular 'reprise' pronoun **I** in (12), on which I will return.

The first clause of PMP II is more difficult to illustrate. Roughly, the implication is that, whenever specific tokens of the entity are not considered, but rather an undifferentiated group or mass thereof, plurality should not be marked. With things or non individualized animals this cognitive option may almost always be exercised, with the consequence that only nouns denoting humans or humanized animals are regularly marked as plural when PMP II is active.<sup>9</sup> Consider the following examples:

- (14) Sardinya ta perga n kornu ami Kornobif. (HGCS)  
 S. A nail me horn I K.  
 'Sardinya has me wear horns, I Corned Beef.'
- (15) Mandadu i ta friyanta pe, ma i ka ta friyanta korson. (TM)  
 be-ordered it A cool foot but it NEG A cool heart  
 'Having things done [by others] cools the feet, but it does not cool the heart.'
- (16) Sapu Fora sinta na nyeme kola disna di novi oras di parmanyen  
 S. F. sit A munch cola since of nine hour+PL of morning  
 te sinku oras di tardi. (FJDM)  
 until five hour+PL of evening.  
 'Sapu Fora sat munching cola nuts from 9 AM until 5 PM.'

In (14) and (15) reference is to objects which come in pairs, hence must be pluralized in English (and in Portuguese). In Kriyol, however, the pair itself may be considered as a whole and the noun denoting it left unmarked. Sentence (16)

exemplifies the ordinary treatment of nouns referring to articles of food (e.g. **n kunpra kamati** 'I bought tomatoes', lit. 'tomato' — cf. French *J'ai acheté de la tomate*) and similar goods (e.g. bricks, books, etc.) which do present themselves as separate 'particles', but may be conceived of as groups or sets.<sup>10</sup> That this option is indeed always available is shown by (13). In fact, given the syntactic structure where **ciw** is the head of the VP having **sancu** as a subject, this is more an example of non-specificity than of non-redundancy. That is to say, it is not monkey-individuals that are in focus, but rather monkey-as-a-species. Besides, it is probably impossible and undesirable to keep both provisos of PMP II strictly separate, inasmuch as indefinite quantification (many, lots of, some, etc.) leads naturally to non-individualization. I suspect that (11) is a case in point with **minjer** unmarked for plural at least as much because the speaker chooses not to consider the women individually — with the usual derogatory side effect when this is done to human beings — as because of the presence of a necessarily plural item like **manga di**. Note furthermore that **manga di minjeris** is perfectly acceptable even under PMP II, since the obligation of preserving the individuality of humans normally overrides the non redundancy rule when there is a conflict.

The difficulty of presenting a coherent account of present day central Kriyol as far as plural marking is concerned then lies in the fact that PMP I and PMP II, descriptive artefacts in any event, are not only copresent in the speech community, but in the mind of each and every speaker-hearer, who may resort to one or the other at any juncture in their current speech. Some of this alternation is not quite unpredictable. For instance, PMP I is regularly used with expressions of time as in (16) in **novi oras** and **sinku oras** — which come right after an application of PMP II. On the other hand, PMP I is never applied to phrases denoting sums of money (**des mil pes** '10 000 pesos', not **\*des mil pesus**). As a whole, PMP I may be gaining ground in Bissau with the increasing influence of Portuguese. Plural marking according to it is extremely frequent in comic-books, for instance, which reflect the on-going evolutions fairly well. There are domains, however, where PMP II seems well entrenched. Nobody, I'll wager, will say or write anything like **\*n kunpra kamatis** or the already mentioned **\*x pesus** — at least so far. Less and less people, on the other hand, would still use **dus bajuda** or **dus karu** instead of **dus bajudas** 'two young girls' or **dus karus** 'two cars'. Still less, perhaps, would use unmarked **bajuda** or **karu**, leaving it to the context to decide whether there is one or more exemplars of the entity, something which PMP II definitely permits.

To sum up, and with all due precautions, the present situation (1990) might be as follows. PMP II is regressing but still holding fast in the domain of inanimate objects when conceived of as groups or natural sets. Absence of individualization

seems to be a stronger cognitive motive for not marking plurality than mere non-redundancy. Finally, there is a tendency to always disambiguate number when it is not otherwise indicated and the entity is not one of those the individuality of which may easily be discounted (as human beings or discrete objects such as cars). As we shall see below, this interacts to a certain extent with the indication of specificity.

If PMP I finally wins out, it will result in a simplification of Kriyol grammar, at least as far as the semantics of /-s/ is concerned, thus providing us with a counter-example to the claim that decreolization always entails complexification.

#### 4.4. The determiners

In this section we take off from the noun proper to reach a first level of expansion within phrases built on it. I will assume the NP structure adopted in Gazdar et al. (1985:126), i.e. with a specifier position under NP (alias N2) as a sister to the next lower level N1:<sup>11</sup>

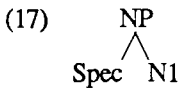

A language-specific LP rule ensures that specifiers come first in Kriyol:

(18) Spec < N1

The items that may occupy the specifier position, which I regrouped under the general heading 'determiners', are the article, demonstratives, possessives, quantifiers, and numerals. They may appear separately or together, with certain restrictions as to the permissible collocations. We will now examine them in turn.

##### 4.4.1. The article

The singular is justified by the fact that there is only one lexical item that may be so classified, viz. the 'indefinite' article *un* (P. *um/uma*), which also functions as the numeral meaning 'one'. Clarifying the meaning(s) of this item as well as that of the complementary case when the specifier position is empty will be the main, even the only purpose of the present section.

The definite-indefinite contrast as it manifests itself in languages like English or Portuguese is often correlated with the distinction between what is presupposed and what is new (in the common world sustained by the participants). Just as often,

the difficulty of maintaining this correlation across the board is acknowledged. That the use of **un** can indeed be associated with newness and that of nothing with presupposedness is demonstrated by the following examples:

- (19) I yera ba un tarbaju garandi pa mi. (I)  
 it be+PAST PAST a work big for me  
 'It was a big work for me.'
- (20) La ja tarbaju yera menus. (I)  
 there already work be+PAST less  
 'There, the work was already less.'

Both sentences were uttered in sequence in the course of the same interview. Both occurrences of **tarbaju** refer to the same kind of work (school work). In (19), the designation is introduced for the first time in the discourse. **Un** brands it as a new fact in the shared conscience of the participants. No such marking is then required in (20), as the shared conscience may be assumed to have been held intact. Newness would thus appear as the marked member in the informational contrast.<sup>12</sup>

The latter, however, does not suffice to characterize all uses of **un** vs. nil. Consider the examples below:

- (21) E storya li n kontadu el pa un omi musulmanu ku  
 this story here I be-told it by a man muslim that  
 comadu Man Sanya. (MK)  
 be-called M. S.  
 'I was told this story by a Muslim named Man Sanya.'
- (22) Na un tardi di sol nyu Kornobif sinta linpa si arma. (HGCS)  
 in a evening of sun Mr K. sit clean his weapon  
 'By a sunny evening Mr Corned Beef sat down to clean his  
 weapon.'
- (23) E gaža li i ten un kaw ku n ciga di oja l ban el.  
 this girl here it have a place that I already-do of see her PAST in+it  
 'This girl, there's a place, I've already seen her there before.' (HGCS)

Not only are the Muslim, the evening, or the place new in the given worlds, they are, in a much more relevant sense, unspecified at the time when the worlds open up. The fact that (21) was cast in the passive is significant. Take the active counterpart: **(un) omi musulmanu kontan e storya li**. Here, **un** is optional, so that, when it is omitted, **omi musulmanu** may translate as either 'a Muslim' or 'the Muslim' according to the context. The interesting fact is then that there is an interpretation of the empty specifier where it is in fact associated with newness. Examples of such an association are extremely common. Here are just a few:

- (24) N na disa pilon na porta pa sedu sinal kuma n sta ami son  
 I A leave pestle in door for be signal that I be I alone  
 dentru. (HGCS)  
 inside  
 'I'll leave the/a pestle in the door as a signal that I'm alone inside.'

- (25) Bilyetis na bindidu na kil kaw. (RB)  
 tickets A be-sold in that place  
 'Tickets are being sold in that place.'
- (26) I na bin dadu karton di konvidya a tudu artistas ku toma  
 it A BIN be-given card of invitation to all artists that take  
 parti. (RB)<sup>13</sup>  
 part  
 'Cards of invitation will be given to all participating artists.'

Tickets and cards in (25-26) are as much new pieces of information as may be desired. In (24), *pilon* 'pestle' has an ambiguous status. Either the speaker assumes or takes it for granted that the hearer knows there is only one pestle in the household, or remembers that a certain pestle is always used as a signal, in which case 'the pestle' is the right translation; or she assumes nothing of the sort — or she indeed owns several indifferentiated pestles — and 'a pestle' is correct. Both interpretations of (24) are equally natural, given a context.

What is at stake here, it seems to me, is clearly specificity in the sense the term was used in connexion with aspect distinctions. That is to say, the issue is whether the entity can be — at least in principle — identified at will, or whether it cannot be; whether, in other terms, one or a definite number of extensional representants of the entity can or cannot be pointed at. Kriyol *un* unambiguously denotes that the entity it modifies is not identifiable. More accurately, the speaker using [un NP] is explicitly assuming that the hearer(s) is/are unable to identify the entity denoted by NP and need be told about it (see 'a Muslim named Man Sanya'); or s/he is explicitly signalling his/her own inability to identify it (see 'there is a place'). Of course, the said entity is generally new as opposed to presupposed or already known. But this is only, I think, a side effect or a natural consequence of its basic non specificity.

Two more possibilities are available besides marking something as non specific. One is to mark it as specific, i.e. readily identifiable. This is one of the things the so-called definite article does in English or in Portuguese. The other is to take no explicit stance as to the eventual identifiability of the entity. I will assume this is precisely the tack followed by Kriyol grammar. That is, whenever an NP is used with an empty specifier as in (24-26), it is because the speaker considers (in an implicit fashion, of course) that the specificity issue is simply not relevant in the present context. Now, there are several reasons why this may be so. It may be so because it goes without saying that the entity may be identified. *Porta* in (24) is an illustration; it is beyond reasonable doubt that the hearer knows which door is meant. Universally known objects of the world like *sol* 'sun', *luna* 'moon', etc. also belong to this configuration, *naturaliter* in their case. But it is important

to realize that any entity may be conceived of in this way, in some mental space or other. This explains why empty specifiers are often encountered where definite articles are expected in the English or Portuguese counterparts.

The other possible reason is because the eventual identification of some real instance(s) of the denoted entity is genuinely irrelevant to the discourse being made. Such is indeed, I think, the ultimate explanation for *pilon* in (24). It simply doesn't matter to the speaker what the hearer knows concerning the ontology of the pestle that will serve as a signal.<sup>14</sup> Hence the dual English (or Portuguese) translation. A duality that cannot be resolved, insofar as English and Portuguese must here make a choice ('the' or 'a', *o* or *um*) that has no existence in Kriyol. Similarly, *bilyetis* and *karton* in (25) and (26) would be considered non specific at first blush (see the empty specifiers of English 'tickets/cards' or Portuguese *bilhetes/cartões*; French would use indefinite plural *des* here). But the end of the matter is that the issue of individualizing specific tokens of tickets or cards simply does not arise. Here, English and Portuguese grammars are similar to Kriyol grammar, but only with pluralized nouns. This number constraint plays no role in Kriyol.<sup>15</sup>

To sum up, the preceding discussion may be condensed into the two following FCRs:

(27) FCR: [Spec un]  $\Rightarrow$  [-SPECIFIC]

(28) FCR: [Spec  $\emptyset$ ]  $\Rightarrow$   $\neg$ [SPECIFIC]

If *un* fills up the specifier position, then the NP is interpreted as non-specific; if the specifier position is unfilled, then the NP is undefined as to specificity. That is, of course, insofar as specificity may be considered a Boolean feature. As a practical measure, taken for the sake of easier description, it may pass. It should be obvious, however, that specificity is only a name for the cognitive consequence of the complex interplay of what may be characterized as mental worlds or spaces (see Fauconnier 1984). This is why I will refrain from any further formalization, be it logical formulae or schemata, as I do not think they would throw much more light on the problem than did my informal exposition.

Before closing the present section, another phenomenon must be dealt with. One function of the definite article is what is called the 'anaphoric' function, i.e. that of signalling that the entity denoted by the NP has already been mentioned, *verbatim* or in different words, in some preceding discourse somehow connected to the present one. According to a number of scholars, this function figures prominently in creole languages that have a definite article, like Haitian or Guyana Creole (see, e.g. Valdman 1978; Bickerton 1975). In Kriyol, it may be fulfilled by the empty specifier, as a special case of self-evident specificity. But it is also

possible — and this is a growing possibility, it seems — to have recourse to an item we will meet again later on, viz. the distal demonstrative *kil* ‘that/those’.<sup>16</sup> Although it is often difficult to decide whether one is dealing with the ‘true’ deictic demonstrative or its anaphoric usage, here is a rather clear, I think, example of the latter:

- (29) *Kil asasinus bin di elikóteru.* (RB)  
 those/the murderers come from helicopter  
 ‘The murderers came from a helicopter.’

Here, in the middle of a broadcast piece of news, *kil* can have no function but that of indicating that the murderers referred to are the very same that were talked about all along. When used anaphorically *kil* cannot be reinforced with *la* following the head noun (*kil asasinus la* could only mean ‘those murderers’ with deictic force — see below).<sup>17</sup> The following dialogue is another case of anaphoricity where the answerer makes it known that the individual referred to — who was nowhere to be seen at the time of the exchange — has already been mentioned to him:

- (30) Q: *Jean -Louis, bu kungsi l?* (AK)  
 J. -L. you know him  
 ‘Jean-Louis, do you know him?’  
 A: *Kil kurtu?* (I)  
 the short  
 ‘The short guy?’

This use of *kil* has no character of obligatoriness so far. Whether it will evolve towards systematicity, as in Cape-Verdean, depends mainly on the amount of time that is left to Kriyol.

To conclude on a contrastive note, the Kriyol system for marking (non-)specificity seems rather difficult to compare with that of its source language. The Portuguese definite article *o(s)/a(s)* disappeared entirely during the creolization process, nor was there anything in the language that could be reanalysed to be used in its stead, like, e.g., the French deictic postposed particle *-là* which gave rise to the Haitian and Lesser Antilles Creoles article *-la* (e.g. Martiniquais *bagay-la* ‘the thing’). Kriyol had thus to reconstruct its own system on a shifted basis, using as a pivot the only surviving item *un*.

This system bears a certain resemblance to that of Mandinka, except that the marking pattern seems to be reversed. Mandinka nouns have a so-called ‘suffixed’ form (e.g. *súnkuto* ‘girl’ vs. *súnkutoo* ‘the/a girl’) the effect of using which is ‘to focus the attention of the hearer upon the person or thing denoted by the Noun [...] Used with a word at its first occurrence it signals «take note of the particular class of object to which I am referring»; at a repetition of the word it signals «take note



that the object now referred to is the same as that referred to before» (Rowlands 1959:150). Claimed vs. indifferent specificity seems thus to be what is marked by the Mandinka suffix/article /o/.

The surrounding Atlantic languages, on the other hand, are still too poorly studied in this area for a meaningful comparison to be feasible. Manjaku would seem to contrast a marked unspecific form (e.g. *kalon kato* /one house ‘a house’) with an unmarked form (*kato* ‘the/a house’), which would make it quite similar to Kriyol. Yet, whether this is the relevant contrast remains to be checked.

Finally, a contrastive analysis of Kriyol along with the other Atlantic Portuguese Creoles would surely yield highly instructive results.

#### 4.4.2. The demonstratives

There are two demonstrative deictic items in Kriyol, proximal **es** (P. *esse/a* and/or *este/a*) and distal **kil** (P. *aquela/a*). Both have apocopated forms **e** and **ki**, whose distribution does not depend, it seems, on phonological factors such as the nature of the initial segment of the following word:

- (31) E purblema ka na fika sin. (FJDM)  
       this problem NEG A stay so  
       ‘This problem won’t stop here.’
- (32) Jubi son ki algin ku firma la. (FJDM)  
       look only that person that stand there  
       ‘Just look at that guy standing there.’

Proximity or distance is measured relatively to the speaker. It may be material as in (32), or it may be ideal as in (31). It may concern space or time or both. Choosing one or the other form is thus determined by cognitive features of the objective or subjective situation, as it is tacitly assessed by the speaking individual.

The orientative import of **es** and **kil** can be further reinforced by postposing the locative adverbs **li** ‘here’ and **la** ‘there’ respectively to the head noun — see (23) **e gaža li** ‘this girl’; here the speaker has just passed the girl in question and he is looking at her as she is walking away. In fact, **li** and **la** must follow the whole N1 as in, e.g., **e gaža bonitu li** ‘this nice girl’. It seems therefore a good descriptive solution for such collocations to have **es... li** and **kil... la** constitute discontinuous elements as in (33) below:

- (33) 
$$\begin{array}{c} \text{NP} \\ \swarrow \quad \downarrow \quad \searrow \\ \text{Sp} \quad \text{N1} \quad \text{Sp} \end{array}$$

This representation does not show two specifier positions, but one distributed one, corresponding to one lexeme, [es(... li)] or [kil(... la)]. That only **li** may combine with **es** and only **la** with **kil**, not vice-versa, is readily explained by the logic of unification, since **es** and **la** as well as **kil** and **li** bear contradictory features for the far-near contrast, which cannot be unified.

Representation (33) complements (17) above. It ought therefore to be modified as follows for full generality:

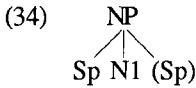

Tree (34) is in turn licensed by the non lexical ID rule (35):

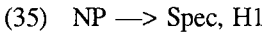

LP rule (18) is no longer adequate, however, to guarantee the well-formedness of (34) as a linearly ordered tree. I will then replace it with the slightly modified (36), which I couch in some sort of an autosegmental format, as befits the possibly discontinuous character of the items interfaced with (35):

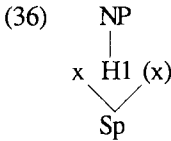

The first x marks the obligatory position which must precede H1; the second, bracketed x marks the optional position lexically linked to the first one, which must follow H1.

#### 4.4.3. The possessives

The so-called possessive ‘adjectives’ of Kriyol are also introduced under (35) and (36), which means they precede N1 (aka H1). Here they are, synoptically and in a few examples:

|   | SG  | PL               |
|---|-----|------------------|
| 1 | nya | no               |
| 2 | bu  | bo               |
| 3 | si  | se <sup>18</sup> |

- (36) Bu miti bu mame nya sintidu na oreja. (HGTM)  
 you put your mother my advice in ear  
 ‘Bring my advice to your mother’s ear.’

- (37) I furtadu si galinya. (MCDM)  
 s/he be-stolen his/her chicken  
 ‘They stole him/her his/her chicken.’

- (38) Tudu gèrèrus ba vinga se kunpanyerus ku matadu na  
 all warriors go avenge their comrades that be-killed in  
 Mandin. (MK)  
 Manding  
 'All warriors went to avenge their comrades killed in the Manding.'

Kriyol possessives call for few remarks. The main innovation with respect to Portuguese — excepting the loss of the second person singular *teu/tua* 'thy' which is not particular to possessives — is the appearance of a third person plural form referring to plural possessors, whereas Portuguese uses *seu* in all cases (e.g., *o(s) guerreiro(s) foram/foi-se para vingar(em) os seus companheiros*). This may be a case of indirect influence from the substrate languages, as none of them fails to make this distinction. As a result, Kriyol has no use for such constructions as *os amigos deles* 'their friends', which are used in Portuguese whenever disambiguation is felt to be necessary.<sup>19</sup> There is little doubt that *si* and *se* both proceed from *seu*, but the diachronic process of this bifurcation is unclear.

Finally, it may be worth noting that Kriyol, like its source and substrate languages, has no special reflexive form, so that, e.g., *i oja si primu* may mean either that s/he saw his/her own cousin, or that s/he saw some other person's cousin. More on such 'binding' facts below.

#### 4.4.4. Quantifiers and numerals

Kriyol numerals are clearly inherited without much transformation from Portuguese: *un, dus, tris, kwatru, sinku, seys (sis), seti, oytu, novi, des, vinti, vinti-i-un, vinti-i-dus, ... , trenta, kwarenta*, and so forth.<sup>20</sup> Between ten and twenty, two systems still coexist, the old one using addition (*des-ku-un*, lit. 'ten and one', i.e. 'eleven'; *des-ku-dus* 'twelve'; and so forth); and the new one which is merely Portuguese (*onzi, dozi*, and so forth). Needless to say, central speakers in Bissau use the latter almost exclusively.<sup>21</sup> As far as position vis-à-vis the head is concerned, Kriyol also follows the Portuguese pattern of preposing the numerals, whereas the surrounding Atlantic languages (except Wolof) and Mandinka consistently postpose them. *Un* 'one' is usually distinguished from *un* 'a' by adding *son* 'only' to it:

- (39) Tisi n de un son pa li. (FJGK)  
 bring me DE one only by here  
 'Bring me one over here!'  
 (40) Sinku pes kada un son. (FJGK)  
 five peso each one only  
 'Five pesos for each one.'

A word should be said about the ordinals **purmeru** 'first', **segundu** 'second', **terseru** 'third', **kwatru** 'fourth', and so forth. Only the first three are used with some frequency, and mostly predicatively (e.g. **omi ku na bin purmeru** 'the man who is coming first'). Attributive usage occurs mainly in formal discourses (as in **konvokason di un terseru reunyion** (RB) 'the convocation of a third meeting'), and may therefore be considered a chunk of Portuguese grammar within Kriyol. In ordinary situations, people will prefer to resort to the cardinal number preceded by **di** 'of' (e.g. **omi ku na bin di kwatru** 'the man who is coming fourth'; also **di kwatru** 'fourthly'), or to eschew the difficulty by remaining imprecise.<sup>22</sup>

Numerals occupy the specifier position as shown in (39) and in the following example:

- (41) Es nya dus fiju. (W)  
       thismy two son  
       'These two sons of mine.'

Here is a first illustration of the possibility of multiply-filled specifier positions in Kriyol:

- (42)
- ```

      NP
     / \
    Sp  N1
   / \  |
  / \  |
es nya dus fiju
  
```

Note, however, that the order of the elements in (41) — and elsewhere (see below) — is fixed, which is perhaps not naturally expressed with such a flat structure as that of (42). A better solution, then, might be to add another non lexical ID rule after (35):

- (35') H1 → Spec, H1

thus licensing trees like

- (43)
- ```

 NP
 / \
 Sp N1
 / \
 Sp N1
 / \
 Sp N1
 |
 NO
 es nya dus fiju

```

And we also need a semantic hierarchy of specifiers which, according to (41), has to be as follows:

## (44) DEM &lt;&lt; POSS &lt;&lt; NUM

The higher specifier in the hierarchy will be introduced by (35), the next ones by iterative applications of the extension (35').

Of course, numerals may be used in NP positions:

- (45) Na no ermondadi anos bajudas i tris, rapasis i sinku. (MC)  
 in our sibling-group we girls it threeboys it five  
 'Among us brothers and sisters, we girls are three, the boys are five.'
- (46) Nin un son di bos ka na riba bibu pa Kansala. (MK)  
 not-even one only of you NEG A return alive for K.  
 'Not even one of you will return alive to Kansala.'

Adjective quantifiers are very much like numbers, except for the fact that they denote indefinite or, more accurately perhaps, non discrete quantities. A good sample of them is illustrated below, where one can easily verify that all these items conform both to the ID rule (43) and to the hierarchy (44).

- (47) Si manga di limarya. (I)  
 her lot of animal  
 'Her many animals.'
- (48) Kacur, tudu kaw ku i oja sancu, i ta serka pa panya. (I)  
 dog all place that he see monkey he A chase for catch  
 'Dog, wherever he sees Monkey, he will chase him to catch him.'
- (49) Kaw tudu inci ku pekadur. (MM)  
 place all fill with person  
 'The whole place filled up with people.'
- (50) I manda coma janan si irmoms tudu. (I)  
 he make call at-once his brothers all  
 'He had all his brothers called at once.'
- (51) Kada tribu ten si lingwa. (I)  
 each tribe have its language  
 'Each tribe has its language.'
- (52) Kwas nya bida tudu. (I)  
 almost my life all  
 'Almost my whole life.'

From (48) compared with (49), it would be tempting to conclude that **tudu** (*P. tudo*) is indeed a quantifier when it precedes the head, but an ordinary adjective meaning 'whole, complete' when it follows it. That it is a hasty conclusion is shown by (50); **si irmoms tudu** is entirely synonymous with **tudu si irmoms**, and **tudu** is as much a quantifier in one or the other construction. I interpret this as a confirmation of the reality of a post-head specifier position. It is a property of **tudu** that it may occupy the pre-head or the post-head position.<sup>23</sup> The difference in meaning between (48) and (49) is then more a function of the semantics of the head itself (a pluralized noun vs. a non-count one) than of **tudu**'s collocation.

- (53) I ba kuji bruta di karnel. (I)  
 he go pick brute of sheep  
 'He went and picked an enormous sheep.'
- (54) Kil un bruta di baka. (I)  
 the/that a brute of cow  
 'The enormous cow.'
- (55) Utru si kunpanyeru. (I)  
 other his companion  
 'Another companion of his.'
- (56) Ami n ta kunfundi ba senpri kriyol ku purtugis purkë i  
 me I A confound PAST always Kriyol with Portuguese because it  
 ten utru palabras ki ta juntu. (I)  
 have other words that A equal  
 'I always used to confound Kriyol with Portuguese because there are  
 some words or other which are the same.'
- (57) No ka tene nin un koladi dokumentu li. (FJDM)  
 we NEG have not-even a sort document here  
 'We haven't got the slightest sort of documents here.'

The interest of (54) is mainly that it supports the analysis of **un** as a morpheme denoting non-specificity. Indeed, one sees here that **un** is perfectly compatible with the anaphoric **kil**, which would be unexpected if it was semantically analogous to its Portuguese etymon *um/a*. In fact, (54) should be glossed as 'The enormous cow that was already mentioned, but of which I have no direct knowledge', a meaning that cannot be rendered in a natural way in either Portuguese or English. Compare (53) where specificity is considered irrelevant.

In (55), we see that an element need not be fixed in the hierarchy of quantifiers. Here, **utru** is positioned as DEM in (44) — or rather as **un** would be (see below) —, hence the meaning, whereas **si utru kompanyeru** would mean 'his other companion' with **utru** positioned as NUM. **Utru** has also the meaning 'some undefined x' as shown in (56). Since 'other' implies some landmark relative to which otherness is assessed (e.g., 'other words' with respect to words I have in mind), this secondary meaning is easily reached by simply removing the landmark.

Finally, (57) contains two elements which may occupy the specifier position. One is **nin** (P. *nem* 'nor'), the NP negation insofar as **ka** can only bear on predicates, as explained in Chapter 1. But note that [W [nin X] Z] necessarily presupposes that [W [X] Z] might or ought to have been the case, hence the gloss as 'not even'. For example, (57) presupposes that the normal state of affairs is to have at least some sort of documents about oneself. The most frequent collocation is thus for **nin** to be used together with **un**, although other possibilities exist.<sup>24</sup> Since **nin** always comes first no matter what is in Spec, (44) must be completed as below:

## (58) NEG &lt;&lt; DEM &lt;&lt; POSS &lt;&lt; NUM

It is safe, I think, to note **nin** as simply NEG since **ka** is excluded from this environment, and the ‘even’ connotation can be deduced from the set of presuppositions that accompany negation in general, and the negation of NPs in particular.<sup>25</sup>

The other interesting item in (57) is **koladi**, also **koldadi**, from P. *qualidade*. Considering the deep phonetic alterations with respect to Portuguese, this is probably an old lexeme, and its most ‘creole’ use may well be reflected in the following verses by the poet Armando Salvaterra:

- (59) Nada i ka oja/ nin koldadi pasu.  
 nothing he NEG see/ not-even sort footprint  
 ‘He did not see a thing/Not the slightest footprint.’

Here, **kol(d)adi** is clearly in the position of NUM in (44). Although **nin (un) kol(d)adi** looks very much like a fixed phrase, other combinations are met (e.g., **es koladi omi** ‘this sort of man’). In addition to this construction, however, there is another one, viz. **kol(d)adi di** NP. Now, it seems quite reasonable to assume that **kol(d)adi** NP may be a shortened version of **kol(d)adi di** NP via reduction of the haplology [didi]. But this would seem to force us into a dual analysis for this item, since **nin un koladi di dokumentu**, for instance, rather calls for the following structure:

- (60) NP  
       Sp nin  
       N1  
       Sp un  
       NO koladi  
       PP  
       P di  
       NP dokumentu

Which structure is also seemingly required for **manga di** ‘lot of’ as exemplified in (47). Indeed, (47) makes it somewhat improbable that (60) should be the structure accounting for it insofar as, according to this structure, **si** ‘her’ would modify **manga**, whereas its semantic import is really onto the head noun **limarya** ‘animals’. What we have here, I think, is another clear case where neither the syntax nor the semantic is able to tell the whole story. Both conduct their own autonomous analyses of the expression, and only their interfacing will give us the entire picture. I therefore propose the following autolexical representation:

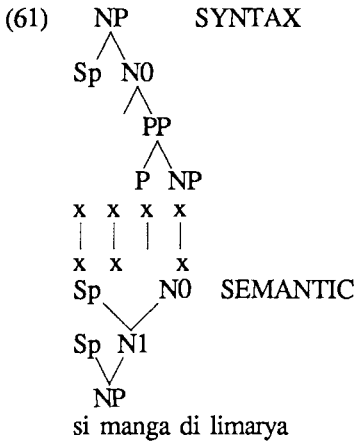

That is to say, **manga di** (likewise **koldadi di**) is semantically a quantifying operator modifying the head of the expression it belongs to. Syntactically, it is an N0 subcategorizing for a PP headed by **di**:<sup>26</sup>

(62) NP → H, PP [PFORM di] (manga, koldadi)

The difference between **manga** and **koldadi** is that the former never occurs without the PP (**\*manga limarya**). With **koldadi**, on the other hand, there is a configuration where the syntactic and semantic planes are isomorphic. That such isomorphism should be brought about by something which is ultimately a phonological process (/koldadi di/ → /koldadi/) comes as no surprise in a model where the components are not sequentially ordered, but work in parallel. Also note how the hierarchical semantic structure in (61) accounts for the fact that **si manga di limarya** — or **kil manga di jintis** ‘those many people’ — is in fact slightly ambiguous, inasmuch as the possessive or the demonstrative may also be felt as modifying the quantifier as well, which they can well do since they dominate it. The nuance is almost negligible (compare ‘those many people’ to ‘that quantity of people’), but it suffices to support further the decision that was made earlier of settling for non flat specifiers.

The previous examples do not exhaust the set of quantifiers that may occur in specifier position. The remaining items do not belong to Kriyol **fundu**, though, but should be considered more or less integrated borrowings from the superstrate. Examples are **kwalker** ‘any’ (P. *qualquer*), **algun** ‘some’ (P. *algum(a)*), **sertu** ‘certain’ (P. *certo*), **kwas** ‘almost’ (P. *quase*), etc. This is a domain where decreolization is rife, as in the following recorded phrases: **na diferentis palabra**



'in other words', *alguns funsyonaryus* 'some civil servants', *algumas palabra* 'some words', *un pokus kusas* 'a few rare things' (P. *umas poucas coisas*). Note the erratic pattern of number agreement.

#### 4.4.5. A conclusion on Kriyol specifiers

To conclude on the most salient fact in this analysis of Kriyol NPs, viz. the availability of multiple specifiers, I will now complete the formulation of hierarchy (44) as follows:

(63) NEG << DEM << UN << POSS << NUM

A theoretical instantiation of the above series would be something like *nin kil un si baka* 'not even that certain cow of his/her'. Although acceptable and making sense, such monsters are of course vanishingly rare in actual discourse. I myself never recorded anything as complex as this. Note that the presence of *un* in third position excludes the occurrence of a numeral in the last position. This mutual exclusion is obviously due to the fact that *un* bears a singular feature — after all it also means 'one' — whereas numerals above *un* are inherently plural. It thus follows from the logic of unification and must not be overtly indicated within the hierarchy. I give here two further examples of simpler, not yet illustrated cases of multiple specifier:

(64) Un no garandi atleta. (FJGK)

a our great athlete  
'A great athlete of ours.'

(65) Si e baka maja u es bu bunda ki pikininyu i na  
if this cow hit you this your anus which small it A  
garandi gos. (MSMM)  
big now

'If this cow hits you, this tiny anus of yours will get big at once.'

#### 4.5. Noun phrases with adjective phrases

Example (64) comes duly to illustrate the fact that one, and as far as I am aware only one, adjective may precede the head it modifies. Actually, (64) might well be an effect of decreolization as it calques the Portuguese correspondent *um nosso grande atleta*. On the other hand, *garandi* following the head noun tends to have the meaning 'old' rather than 'great' or 'big'. Preposing it is thus also a way of clarifying the meaning. Whatever the case may be, *garandi* in (64) ought to be assigned a specifier position as in the following tree:

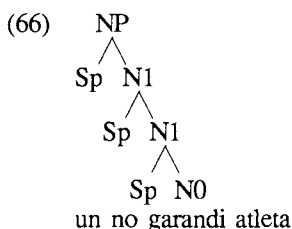

Now, the ordinary state of affairs is for the attributive adjective to follow the noun it modifies: **un omi garandi** ‘an old man’, **kil bajuda bonitu dimas** ‘that very beautiful girl’, and so on. Such construction are easily covered with the two following ID rules:

(67) NP → H1, AP

(68) AP → H1, DEG

plus the general LP statement SUBCAT < ¬SUBCAT which accounts for the fact that the non lexical category AP cannot occur to the left of (a projection of) a lexical head. Neither can a degree adverb like **dimas** whose lexical entry does not include the subcategorization feature. Insofar as **garandi** occurs in Spec it is not affected by rule (67). This optionality in **garandi**’s behaviour should of course be indicated in its lexical matrix.

Little else has to be said concerning the subject. Agreement facts have already been dealt with in various places. Note that it is not usual, or even really possible for Kriyol to adjoin adjectives within an AP as in, e.g., ‘that beautiful, tall girl’, which cannot be translated as **\*kil bajuda kunpridu bonitu**. (Compare Portuguese *\*este rapariga comprida bonita* vs. OK *este rapariga comprida e bonita*.<sup>27</sup>) The only solution in such a case is to resort to a relative clause: **kil bajuda kunpridu ku bonitu** ‘this tall girl who is beautiful’ — see (65) above **es bu bunda ku pikininyu**, fully synonymous with **es bu bunda pikininyu** ‘this tiny anus of yours’. That an N1-AP sequence is always equivalent to and replaceable by an N1-S[+REL] sequence is indeed a semantic fact, inasmuch as adjective phrases and relative clauses both have the same semantic type, viz. from NP to NP.

#### 4.6. Coordinated noun phrases

Apart from general issues which are of no relevance here, the only remarkable fact about Kriyol in this matter is with respect to the source language. Indeed, the Portuguese coordinating conjunction *e* never made it into Kriyol — except recently in decreolized utterances — and it was replaced by **ku**, also meaning ‘with’ (P. *com* ‘with’), as in this example:

- (69) I yera ba un tenpu na tabanka di lubu ku lebri. (I)  
 it be+PAST PAST a time in village of hyena and hare  
 'Once upon a time in the village of the hyena and the hare.'

As we shall see later on, however, *ku* is only fit to coordinate NPs or PPs, whereas a different item must be used in order to coordinate sentences or clauses. The disjunctive coordinator knew no such vicissitudes, on the other hand, and it appears as *o* 'or', a direct reflex of Portuguese *ou*:

- (70) Manga di byas i ta muri mames o se fijus na ora di  
 lot of time it A die mothers or their children in time of  
 padi. (CS)  
 give-birth  
 'Quite often the mothers or their children die at the time of birth.'

#### 4.7. Special types of NPs I: pronouns

In this section as well as in its sequel (Special types of NPs II: nominalized infinitives), 'special' is used to qualify NPs which share the semantic property of not denoting, at least directly, entities of the world such as TREES, SEX, FREEDOM, LINGUISTICS, etc. Infinitives do not denote entities at all but events, which are then in a way envisioned like entities. Pronouns of all kinds do denote entities, but only insofar as they are understood as being used in lieu of the name of an object or an individual which is either somehow known (e.g. 'she') or somehow unknown (e.g. 'somebody'). With this basically semantic definition of what a pronoun is with respect to a noun, I will then proceed to examine the various sorts that are encountered in Kriyol, viz. personal pronouns, reflexive and reciprocal pronouns, possessive pronouns, and finally quantifying pronouns (i.e. items like English 'somebody', 'nothing', and so forth). So-called interrogative ('who', 'what', etc.) and indefinite ('whoever', etc.) pronouns will be delayed until Chapter 6, because their use interferes with that of unbounded dependency constructions.

##### 4.7.1. Personal pronouns

Kriyol personal pronouns can be divided into two main categories, the non-argumental (non-A) and the argumental (A) pronouns. Consider the following example:

- (71) Amí n ta kria limarya. (I)  
 I I A raise animal  
 'As for me, I raise cattle.'

What characterizes **amí** is that it can never be the argument of a predicate or a verb, but must remain outside the sentence with which it is nevertheless construed. In contrast, **n** must be the argument of a predicate or a verb. A possible structure for (71) is therefore (72):

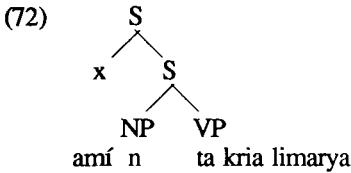

where the **x** position accommodates items with topical or focus force. Before I try and analyse the relationship between non-A and A-pronouns a bit further, I will first present the full list of these items.<sup>28</sup> A-pronouns include a Case feature, and they appear under three forms according to whether their grammatical function is subject (nominative), direct or indirect object of a verb (objective), or object of a preposition (oblique):

|                |           |         |
|----------------|-----------|---------|
| Non-A pronouns |           |         |
| amí anós       |           |         |
| abó abós       |           |         |
| el elis        |           |         |
| A-pronouns     |           |         |
| Nominative     | Objective | Oblique |
| n no           | n no      | mi nos  |
| bu bo          | u bo      | bo bos  |
| i e            | l elis    | el elis |

To these, two ‘polite’ forms of address should be added, **nyu** for men and **nya** for women.<sup>29</sup> The latter is amply illustrated in the following example:

- (73) N gosta ciw di nya porki nin ku algin jubi nya na  
 I like much of you because not-even that somebody look you in  
 rostu i ta sibi kuma nya bon na kuzinya. (FJDM)  
 face he A know KUMA you good in cooking  
 ‘I like you very much because no sooner does somebody look at you  
 in the face than he knows you’re good at cooking.’

Both have non-A forms after the common model, viz. **anyú** and **anyá**:

- (74) Anton anyú gosi i tuga. (HGCS)  
 then you now it Portuguese  
 ‘So now you are a Portuguese?’

There is even a comitative, at least in the feminine, meaning ‘you women’:

- (75) Banyas ta kungsi algin ora ku banyas foronta.  
 you-women A know somebody time that you-women get-aggrieved  
 ‘You women know a guy when you are aggrieved.’ (HGCS)

This and the probably acceptable masculine equivalent *banyus* seem to be fairly recent, slightly slangish formations. Originally, polite address was reserved for old people to whom respect had to be shown as a matter of course. All other persons were treated as *bu* 'thou' or *bo* 'ye'. Presently, *nyu* and *nya* tend to be used more and more as *você(s)* is in European Portuguese or polite *vous* in European French, *bu/bo* being restricted to intimates, friends, workmates and the like. The change is only incipient, though, which means the old usage is still perfectly acceptable.

From a diachronic point of view, it appears as if the oblique forms came closer to the putative Portuguese etyma — compare *mim, vós, ele, nós, eles*.<sup>30</sup> The non-A forms are then easily derived by amalgamating the members of the oblique paradigm with the preposition *a* which is otherwise absent from Kriyol. In the third person, the sequence *\*a ele(s)* would normally result in simple *el(is)* through reduction of the hiatus. The kernel of the derivation is probably such Portuguese constructions as *bateu-me a mim* 'S/he struck me'.

By contrast, the nominative and objective forms seem much more altered with respect to Portuguese. A look at the surrounding languages makes it immediately apparent that conflation played a major role in shaping these forms. A syllabic nasal or a nasal plus a vowel to denote first person singular is ubiquitous in Mande and Atlantic languages (as well as in Niger-Congo generally). It is also a general tendency for the third person singular to be expressed through a morpheme comprising one vowel only (see Manjaku *a* 's/he/it').<sup>31</sup> The Manjaku 3SG objective pronoun *ul* and Kriyol *l* constitute an almost perfect match. So do Manjaku 2SG objective *u* and Kriyol *u*.

More generally, the substrate languages probably supplied the overall pattern of contrasting non-A with A-pronouns. Such a pattern is invisible in Portuguese, a null subject language where overt subject pronouns are necessarily imbued with some contrastive or highlighting force (compare *escrevo* 'I write' with *eu escrevo* 'I write').<sup>32</sup> It thus looks as if the Kriyol subject pronouns fulfilled the function that Portuguese imparts to inflectional endings, suggesting an analysis in terms of clitic pronouns spelling out the AGR element of an inflectional functional projection (see Chomsky 1982 on the Northern Italian dialects). Needless to say, such an analysis is quite foreign to the descriptive framework applied in this book. I will resist the notion of clitic pronouns as a special category, in particular, because clitic-hood is a morphological or phonological notion that has nothing to do in the syntax, where pronouns simply occupy the positions that the NPs they stand for would fill up. Moreover, there is no clear sense in which nominative pronouns cliticize to something else. Not being stressed cannot certainly count as a sufficient condition. Only with n 'I' ([[+N][-V][+PRO][+ARG] [PRS 1][-PL][NOM]]) is it empirically

warranted to assume morphological cliticization to the following verbal element (see Introduction).<sup>33</sup> I will therefore assign the following autolexical representation to, e.g., **n ta skirbi** 'I write':

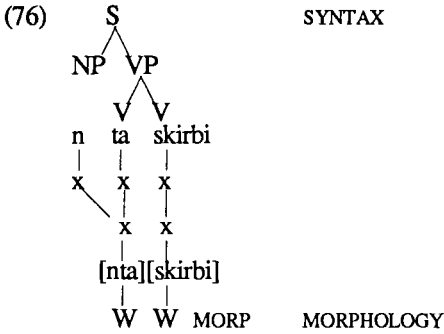

I see no compelling reason, on the other hand, for not having the syntactic and the morphological levels isomorphic in the case of **bu VP**, **i VP**, and so forth.

Objective pronouns, which find direct equivalents in the source as well as in the substrate languages, are more unitary in that they all cliticize to the right of the verb which governs them, so that **n ta skirbi l** 'I write it' may be represented as follows:

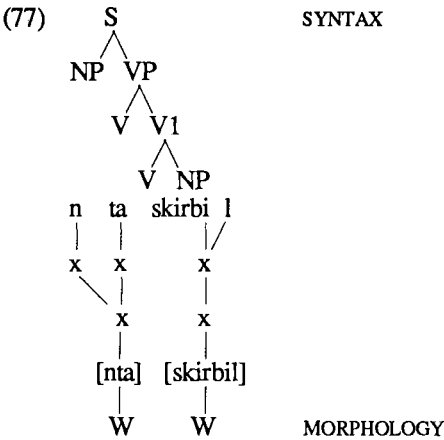

The phonological processes triggered by objective pronoun cliticization have been described in the Introduction. Of course, objective pronoun cliticization is subject to an adjacency condition as shown by double object constructions:

- (78) Bu ka na pati n el? (I)  
 you NEG A offer me it  
 'Aren't you going to offer me it?'

Since the second objective pronoun is not adjacent to the verb, it cannot cliticize and the non-A form has to be chosen. I say the non-A form rather than the oblique one (indistinct in this case) in spite of the rare instances — rare because semantically improbable — where a pronominal second object (O2) is not third person and non-A pronouns are excluded nevertheless:

- (79) (a) \*I na nterga n abó.  
 (b) I na nterga u na mi/na nya mon. (I)  
 he A entrust you to me/in my hand  
 'He will entrust you to me.'

The first object (DO) has to be 'externalized' and changed to some sort of beneficiary PP (see Chapter 2 for double object constructions). Only in the third person can (and must) the non-A form be used in such an apparently argumental position. In will try and explain this exceptionality in what follows. Meanwhile, note that oblique pronouns are as stringently forbidden in candidate constructions like (79a) — \*i na nterga n bo. Oblique pronouns cannot occur but as complements to prepositions.

How can we account for this choice of forms without resorting to a syntactically unmotivated 'clitic' feature? I propose the following syntactic representation for the VP of (78):

- (80)
- ```

      VP[+FIN]
      /  \
  V[+AUX] V1
           /  \
          V  NP[PRO] NP[PRO, 3SG]
         na  pati n   el
  
```

In accordance with its non-A status *el* is assigned no linking in (80). This admittedly 'quirky' situation will be clarified.

Although 'clitic' is not a syntactic feature, it certainly is a morphological one. That means that objective *n* should have the following (partial) lexical entry:

- (81) *n*
 {<PRO +>, <ARG +>, <PRS 1>, <PL ->, <CASE OBJ>}
 syntax: [VP V__]
 morphology [W V__]
 interface: strong LC, strong CIC

The interface line in (81) spells out the fact that *n* must follow the verb it cliticizes to and cannot be separated from it by any other material (see Sadock 1991 for a definition of the Linearity Constraint and the Constructional Integrity Constraint).³⁴ That *n* counts further as the object of the said verb is indicated by the value of the Case feature in the first line. Tree structure (80) satisfies the syntax-morphology interface requirements for *n*, so that [pati n] is a well-formed expres-

sion. The lexical entry for I is identical to (81), *mutatis mutandis*. Now, there is clearly no compatibility between the interface requirements for I and (80), so that *[pati n I] is not well-formed. Nevertheless, here we have a semantic expression, formalizable as

(82) ((pati(1SG))(3SG))

which must find some expression. Let us turn to the lexical entry for the non-A member of the 3SG paradigm:

(83) el
 {<PRO +>, <ARG ->, <PRS 3>, <PL ->, <CASE nil>}
 syntax: [_[VP[+SUBJ]]_]
 morphology: nil

All that syntax requires of *el* and of non-A pronouns generally is that they should be exterior to, although in construction with, the first sentential maximal projection.³⁵ On this ground alone, then, (80) appears as a well-formed structure. There are two problems, though. Firstly, how will *el* count as a verb object in spite of its being non-A? Secondly, how is it that only the 3SG pronoun can be so constructed? This is where the semantic dimension comes into play.

Let us assume the 'normal' semantic-syntax interface for a double object construction to be as follows:

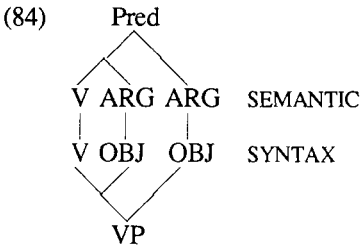

Each argument is associated with a lexical item bearing a Case feature valued as objective.³⁶ If the second argument is a pronoun, however, the interface cannot be satisfied because of the independent requirements of the syntax-morphology interface. There is an interface clash, so to speak, which can only be obviated by using a form which does not depend from the head:

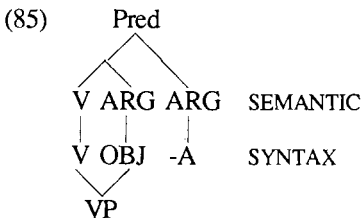

The interface in (85) is all that guarantees *el*'s interpretation as an argument of the head of the predicate. Now we can understand what is implied by *el*'s 'stranding' as in (85) and (80). Indeed, it is not supposed to mean that *el* has no position in the syntactic network, but rather that the precise site of its linking is floating in some real sense. It is not to the V1 because *el* is not a syntactic dependant of the head; it may be to VP or still higher up, more or less at will. In all cases, *el*'s argumenthood is fixed in the semantic module with which the syntax is interfaced. The possibility of thus assuming inherently undetermined syntactic structures is, I believe, an immediate as well as a desirable consequence of the parallel representations approach.

To sum up, the well-formedness of (78) and the ill-formedness of conceivable alternatives result from the interfacing of three autonomous modules, the syntactic, the semantic, and the morphological.

The question that remains is why isn't it possible to generate something like (79a)? I confess I have no satisfying answer to this one. There are a few threads, however, that might lead to a plausible solution. One is the already mentioned semantic oddity of (79a), which can be attributed, I think, to the very meaning of the verbs that require double object constructions, viz. verbs implying the transference of an object from one site (typically an owner) to another (typically a new owner). 'Give' is the prototypical item in this class. Humans, however, are not prototypical objects to be taken in such a relationship. Now the difference between first and second person pronouns with respect to third person is of course that they exclusively refer to human (or humanized) beings, with the consequence that only under very contrived circumstances will they have the opportunity of showing up as second objects. One can surmise that speakers will then somehow balk at constructing such bizarre utterances in the same way that they would perfectly banal ones.³⁷ However that may be, it wouldn't be the only case where first and second person differ from third person, to the point that one may genuinely wonder whether it is right to ascribe them to the same syntactic category (the classical treatment here is Benveniste 1966).

This leads me to another piece of explanation, namely the peculiar character of the Kriyol third person singular pronoun under all its forms. This peculiarity is linked to what I will call its possible 'neutrality', and it has grammatical consequences as we shall see presently.

Before that, I will expatiate a little more on the syntax of non-A pronouns. Two points must be considered: (i) the position of non-A pronouns vis-à-vis the minimal sentence; (ii) the feature and functional agreement between non-A pronouns and sentence internal arguments. The first point is formalized in (83).

Non-A pronouns occur before or after the minimal sentence that they are in construction with. The front position has already been illustrated in (71). Here are three examples of the tail position:

- (86) Sardinya ta nperga n kornu amí Kornobif. (HGCS)
 S. A nail me horn I K.
 'Sardinya has me wear horns, I Corned Beef.'
- (87) Kin ku ten e kacur li ku susa nya konosaba sin amí
 who that have this dog here that soil my loincloth so I
 Naninkiya. (J)
 N.
 'It's the owner of this dog who soiled my loincloth in this way, the loincloth that belongs to me, Naninkiya.'
- (88) Lyon na kume l, el, minjer. (I)
 lion A eat her she woman
 'The lion will eat her, the woman.'

Alternatively, a postposed non-A pronoun may occur between the VP and adjuncts, as in this example:

- (89) N na disa pilon naporta pa sedu sinal kuma n sta amíson
 I A leave pestle in door for be signal that I be I alone
 dentru. (HGCS)
 inside
 'I'll leave the/a pestle in the door as a signal that I'm alone inside.'

The different possibilities may be compacted in the following non lexical ID rule:

- (90) $S \rightarrow VP[+SUBJ], (x), (ADJUNCT)$

To wit, a sentential node may immediately dominate a minimal sentence, an optional extra-sentential adjunct, and an optional extra-sentential position (x) where material with special discourse-functional force may be inserted.³⁸ Linear order has to be provided by a doubly disjunctive LP statement:

- (91) $x < W \vee W < x \vee VP[+SUBJ] < x < W$

where W is whatever is left under the maximal S node.

Ordered non-A pronoun constructions are then interfaced with the discourse functional or pragmatic module (see Sadock 1991a on the necessity of such a module in the autolexical model). Front or tail, non-A pronouns may be roughly analysed as focusses insofar as they denote entities that the speaker wishes to present as somehow new or worthy of attention in the interactive world being sustained. Newness may imply contrast as in (71) or in the following:

- (92) Amí n susu korson. (J)
 I I dirty heart
 'Me, I'm bad.'

Here, the presupposition is clearly, 'Whatever you are trying to do or to be, I warn you that I am bad'. Or it may simply amount to the highlighting of the fact that the mentioned protagonist is now assuming especial relevance, as presumably in (89) or in

- (93) *Abó gora ku bu tene caga abó bu ta bin panya l.* (J)
 you now that you have wound you you A and-then catch it
 'Now you who have got a wound, are you going to catch it?'

True, (93) also contains some measure of contrast. Those are imprecise, rule-of-the-thumb notions which I merely use and won't attempt to improve. In addition, postposed non-A pronouns regularly imply that the contrast has affected the designated protagonist in a negative or contrary to normal way, with indignation as a typical emotional correlate. This comes out very clearly in (86) and (87). In (88), however, postposed *el*, then replicated by *minjer* 'woman', is mainly there to disambiguate the objective pronoun's denotation.

Coming now to point (ii), i.e. agreement, sentences like (71) or (86) would give one the impression that there is a necessary connexion between the non-A pronoun and one of the VP[+SUBJ]-internal arguments, viz. the subject in (71) and the object in (86).³⁹ That things are not that simple is made plain in (87) where the connexion is not with a syntactic argument of the VP, but with a semantic argument of an NP (*konosaba* 'loincloth') spelt out as a modifier in specifier position (*nya* 'my') — hence the awkwardness of the English translation. Furthermore, there are cases like the following with no syntactic connexion at all:

- (94) *Abó si n sibi n ka na konta.* (HGCS)
 you if I know I NEG A tell
 'You, if I had known, I wouldn't have told you.'

Of course, (94) can be considered an unbounded dependency construction (UDC) and assigned the following, fully-connected representation (I simplify by removing the conditional):

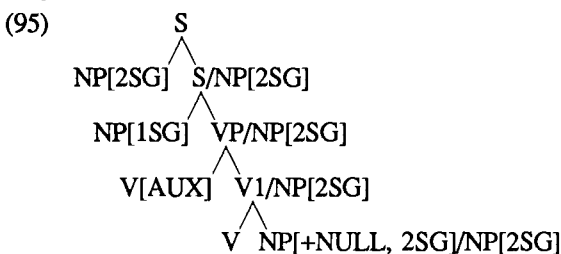

Although unimpeachable on theoretical grounds, (95) is less than satisfactory as a description of (94). Indeed, the simplification of removing the incidental clause *si n sibi* 'if I had known' turns out not to be as innocent as one might have thought it to be, the minute one realizes that *abó* is also somehow an argument of *sibi*. A

logical argument, that is, insofar as the unexpressed object of *sibi* 'know' can only be 'you' syncategorematically interpreted, i.e. 'what you were to do', 'the way you were to behave', and so forth. Yet, no reasonable syntactic connexion can be established from *abó* to *sibi*. Consider further the 'simple' case (71). This is not a UDC since all positions are filled. Neither is it a control structure since the non-A pronoun and the subject pronoun cannot be said to be in a functor-argument relationship. Again, no syntactic principle predicts the agreement of *amí* and *n*, which is entirely a matter of meaning, as is the agreement of *nya* and *amí* in (87) or of *abó* and the two occurrences of *bu* in (93).⁴⁰ Given this, I would like to suggest that the interpretation of sentences involving non-A pronouns in so-called 'focus' position be left to the syntax-pragmatics interfacing, more or less along the following lines:

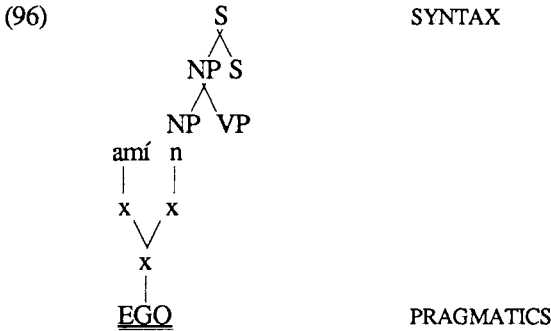

Thus, *amí* and *n* agree in denotation simply in virtue of the fact that they correspond to one cognitive entity in the semantic-pragmatic dimension, viz. EGO. Double underlining is a crude (but cautious) way of suggesting the contrastive, emphatic, etc. force being imparted to the cognitive entity. Similarly, the relevant part of (87) may be represented as in (97):

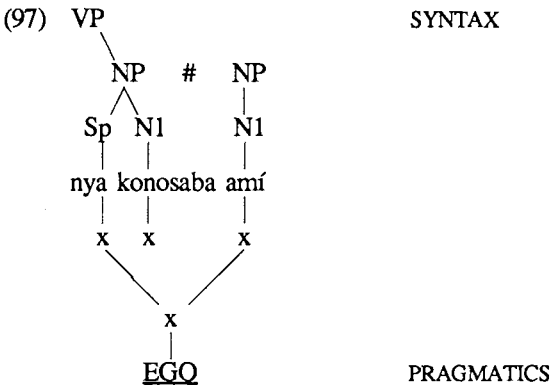

Both NPs in (97) are syntactically disjoint as indicated by the # symbol, which does not prevent them from being semantically and pragmatically connected.⁴¹ We can now reanalyse (94) dispensing entirely with the SLASH notation. In particular, the relationship of **abó** to the unexpressed object of **sibi** — for which SLASH is not available in any event — will be represented thus:

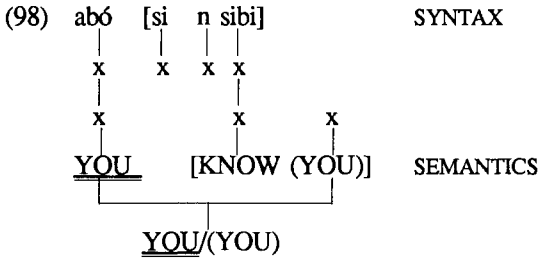

What other frameworks would translate as empty categories or null elements is simply construed in the autolexical model as the interfacing of a ‘really’ unsaturated syntactic predicate (**sibi**) with its saturated correspondent in the semantic plane **KNOW (YOU)**. The brackets around **YOU** are a reminder of the fact that not the entity **YOU** is meant here, but some state of affairs involving (**YOU**). Of course, **YOU** and (**YOU**) are semantically connected. The other unsaturated predicate in the expression (**n ka na konta**) will receive exactly the same treatment, again making the SLASH notation superfluous, even though technically available.

4.7.2. The ‘neutral’ pronoun *i*

I come back now to the special problem posed by the third person singular pronoun, nominative **i**, objective **l**, oblique and non-A **el**. The problem was already alluded to in connexion with the study of noun predicates (see Chapter 1). It is illustrated in the following examples:

- (99) Lubu suma di kustumu i ta buska senpri manera di ranja
 hyena as of habit he A search always way of arrange
 di kume. (I)
 of eat

‘According to his habit, Hyena is always looking for ways of finding something to eat.’

- (100) Bu ka sibi anós tanbi i utrus cokas. (FJDM)
 you NEG know we too it other+PL partridges
 ‘You don’t know we are old foxes too.’

On the one hand, **i** behaves like an ordinary third person pronoun, referring to some individual that is or could be more precisely described at some other place and time, e.g. **lubu** ‘hyena’ in (99). On the other hand, it looks like a neutral

pronoun analogous to English *it* or, better still, French *ça*, which is able to refer back to anything in the world. In (100), the antecedent of *i* is *anós*, a first person plural pronoun. This is in fact generally true with noun predicates, as was briefly explicated above (see Chapter 1). Whatever the person of the entity of which the nominal description is predicated, the syntactic subject of the predicative NP must be *i* (cf. **anós no utrus cokas*).

The following pair of examples shows another typical configuration where *I* or *el* have plural NPs as their antecedents — *algumas palabras* ‘some words’ in (101), *pepels* ‘Papels’ in (102).

- (101) *I ten algumas palabras e ka ta pronunsysa l koretamenti.* (I)
 it have some+PL words they NEG A pronounce it correctly
 ‘There are some words, they don’t pronounce them correctly.’
- (102) *Pepelis i ten manga del.* (I)
 Papel+PL it have lot of+it
 ‘Papels, there’s a lot of them.’

In fact, *manga del* ‘a lot of it/them’ looks very much like a fixed phrase. As can be seen from these examples, the countable or non-countable character of the antecedent NP plays no role whatsoever (witness the oddity of *??pepelis i ten manga delis*).⁴² Finally, we see *el* referring to a clause in (103).

- (103) *I ta bin kada dia pa n pagal el el ku manda i yurni nya*
 he A come each day for I pay him it it that cause he pinch my
 limarya tudu na kintal. (I)
 animal all in yard
 ‘He keeps coming every day for me to pay it to him, that’s why he
 pinches all my cattle in my yard.’

Again *el ku manda* ‘that’s why’ is a fixed expression, with *el* capable of any denotation at all.⁴³

The question we must ask, therefore, is what features of the Kriyol 3SG pronoun are they which give it this capability for universal antecedence, so to speak. More precisely — because noun predicates are, I think, the key phenomenon here — why is it that no pronouns but *i* can be their subjects. (Recall that even full NPs are hardly accepted in this function and are more likely to end up in topicalized position — see *?kil omi karpinteru* ‘That man (is a) carpenter’ vs. OK *kil omi i karpinteru* ‘That man, he/it (is a) carpenter’).⁴⁴

In a previous study of the phenomenon (see Kihm 1990), I hypothesized that the relevant factor might be Case: only tensed verbs would be able to assign Case to their subjects, whereas noun predicates wouldn’t, and *i* would be the only pronoun, nay the only item in the language susceptible of occurring without a Case feature. I now willingly confess to the ad-hocness of the argument. If *i* is nominative in (99), one cannot see why it should not also be in (100), in the absence

of any morphological indication to the contrary. However, I also made the supposition that the neutral character of *i* in terms of person-number agreement, as demonstrated in examples like (100), might be the ultimate explanation of *i*'s no-Case ability. And this, I believe, was a valuable hunch.

In fact, my mistake was to concentrate on *i* alone, while it is the nature of nominal predications as such that must be taken into account. Consider an English expression such as 'ten years is a long time'. The singular copula can only be explained semantically, by assuming that 'ten years' has no individual denotation here as it has in, e.g., 'those were the happiest ten years of my life', but something like a set denotation, to be glossed as 'a duration of ten years' or similar expressions. Put differently, 'ten years' is interpreted syncategorematically as YOU in (98) above, i.e. not to be understood as $(10 \times \text{year})$, a series of ten individual years, but rather as $\{(10 \times \text{year})\}$, a set having ten years as its elements. It is then this set, not the elements, which is described as being 'a long time'. Let us see now how this line of thinking carries over to Kriyol noun predicates.

What we want to say is that *anós* in (100) refers not to the individuals who compose the 'us-group' — here two persons — but to the 'us-group' as such, globally defined as an 'other partridge'. This is a perfectly reasonable interpretation which accords well with the old notion that 'we' is not merely the plural of 'I' (see Benveniste 1966 on this). Granted this, why isn't *anós* simply put in subject position? The fact is that, *anós* being an NP, it might be, à la rigueur — ??*anós utrus cokas* is not worse, but certainly not better than *kil omi karpinteru*. The common option, as already mentioned, is for NPs to be topicalized in noun predicate constructions. But why then can't it be referred back to by the agreeing pronoun *no* 'we' in the minimal sentence?

Here, we need make an unwarranted but, I think, sensible and necessary assumption, viz. that first and second persons argumental pronouns must denote individuals and cannot denote sets. This would correlate with their syntactic definition as NOs, if we accept that set denotation is only possible at the NP level (see Gazdar et al. 1985:188 ff.). Hence, *no* in (100) could not have the same meaning as *anós*, i.e. could not be unified with it as expressing the same entity in the semantic module (see (98)). At this point, *i*'s neutrality comes into play. Neutrality may be understood in several ways. For one, it is a fact that Kriyol — like all surrounding languages — makes no formal distinction as to the natural gender (grammatical gender there is none) of third person pronouns antecedents. Moreover, *i* and its Case variants can point not only to first order entities of the world such as women, men, babies, animals, things, and concepts, but also to second (or nth) order entities such as sets (see (102)) or propositions (see (103)).

The conclusion follows: to the difference of **n**, **bu**, etc., **i** and its paradigm can be an NP as well as an N0. *Qua* NP, it can then have as its antecedent something that is given a set interpretation.

One more piece of argument must be added for the account to go through, however, viz. that noun predicates as opposed to verb predicates necessarily induce a set or syncategorematic interpretation of their logical subjects. Although I will not attempt to prove it (I'm not even sure it can be proved), I would like to suggest this makes a lot of sense. Compare, for instance, 'I'm writing linguistics' with 'I'm a linguist'.⁴⁵ I do not think it is utterly absurd to assume that not quite the same 'I' is predicated of in both cases and that, contrary to the writing, actual 'I', the 'I' which defines itself (?) as a linguist must be understood as a generic 'I', as an 'I-set' in other words (see Arthur Rimbaud's famous line *Je est un autre*). It is probably this distinction which is reflected, in the third person at least, in the well-known contrast between English 'S/he's a linguist' and French *C'est un(e) linguiste*. The basic fact is then that French *ce* exhibits the same neutrality and NP-hood as Kriyol **i**. *Ce* differs from **i**, though, in being by and large restricted to third person antecedents, so that the literal French translation of *amí i lingwista*, **moi c'est un linguiste*, is ungrammatical (but see Haitian *mwen se lengwist*, where *se* can be analysed as consisting of a pronominal element /s-/ and the copula (y)e — see Kihm 1990)).

In sum, the explanation of expressions like (100) lies in the semantics of noun predicates, which induce a non individual, NP-type interpretation of their subjects, combined with the lexical specificity of **i** which, unlike other A-pronouns, allows such an interpretation. Non-A pronouns thus differ further from A-pronouns (but **i**) in not being limited to the N0 level, but being able to assume the status of NPs, i.e. of names like 'Mary', 'the chap over there', 'that thing', and so forth.

Of these, the first phenomenon — the meaning of noun predicates — is certainly universal. The other, viz. the N0 character of A-pronouns, especially in the first and second persons, is probably so too, at least in languages where the category may be detected. What is parochial is the existence of such an item as **i** which makes it possible for the semantic underpinning to show across the board, not just in the third person as in French. Here is therefore a domain where it makes sense to claim that Kriyol is semantically more transparent than English or French or Portuguese where the interpretative peculiarities of noun predicates are more or less completely obscured by the character of the lexical resources.

To conclude this section, I give a plausible multiple-choice lexical entry for *i*:

- (104) *i*
 {<PRO +>, <ARG +>, <PRS 3>, <PL ->, <CASE NOM>}
 morphology: nil
 syntax: N0 v NP
 semantics: [+SPEC [-SPEAKER/-ADDRESSEE (x)]] v [-SPEC
 [-SPEAKER/ADDRESSEE (x)]]

The pseudo-feature [Specific] is used as an easy way of encoding the individual vs. set interpretation that *i* may be given; when non-specific ([-SPEC]), *i* is undefined (→) as to the speaker or addressee status of its antecedent, which may thus be you, I, or some other person(s) or thing(s).

Before we pass to a new topic, some mention must be made of two items which, for want of a better name, may be called ‘demonstrative pronouns’, viz. *es(is)* ‘this/these (one(s))’ and *kila(s)* ‘that/those (one(s))’:⁴⁶

- (105) *Es si i panya n ba ku kil si cifri la.* (FJDM)
 this if he catch me PAST with that his horn there
 ‘If this [a bull] caught me with those horns of his...’
- (106) *Esis tudu tarda ku na tarda e na kay na nya nboskada.* (FJDM)
 these all last that A last they A fall in my ambush
 ‘No matter how long it will take, these guys will fall in my ambush.’
- (107) *N ten di diskubri nunde ku esis miti nel.* (FJDM)
 I have of discover where that these put in+it
 ‘I must find out where these guys put themselves.’
- (108) *Kila ningin ka pudi tuji n el.* (HGCS)
 that nobody NEG can forbid me it
 ‘That, nobody can forbid me it.’
- (109) *E bibinti omi binyu tok kila ka pudi nin firma*
 they make-drink man wine until that NEG can not-even stand
diritu. (K)
 straight
 ‘They made the man drink wine until he couldn’t even stand straight.’
- (110) *Kila i ka baka i lyon.* (I)
 that it NEG cow it lion
 ‘That’s not a cow, it’s a lion.’

As the examples show, *es* and *kila* are like non-A pronouns (105, 106, 108, 110), except that they enclose no special discourse-functional force, so they may also be arguments within the minimal sentence (107, 109). In other words, they, like *i* in one use, are pragmatically neutral NP pronouns, while *ami*, etc. are pragmatically loaded NP pronouns, and *n*, etc. are N0 pronouns.

4.7.3. *The reflexive - possessive pronouns*

This lumping together apparently heterogeneous items is not due to impatience, but to the fact that they do indeed have a point in common, so it seemed convenient to treat them in the same section. I give first a few examples to illustrate the Kriyol reflexive:

- (111) Sanbasuga i ten dus boka ma i ka ta murdi si kabesa. (TM)
 leech it have two mouth but it NEG A bite its head
 'A leech has two mouths, but it does not bite itself.'
- (112) Kacur-di-mangu kuma pa kada kin sibi di si
 mongoose [dog-of-mango] KUMA for every who know of one's
 kabesa. (TM)
 head
 'The mongoose says that everybody should mind their own
 business.'
- (113) N oja nya kabesa na spiju. (DR)
 I see my head in mirror
 'I looked at myself in the mirror.'

As was to be expected, the Portuguese reflexive clitic pronouns *me*, *te*, *se*, etc. (of which only 3rd person *se* is specifically reflexive) — e.g. *olhei-me* 'I looked at myself', *olhou-se* 's/he looked at her/himself' — did not enter Kriyol (at least directly — see below), and they were replaced by a nominal expression made up of a possessive specifier modifying *kabesa* 'head', a quite common means of expressing reflexivity in creole as well as non-creole languages — compare, e.g., Haitian *li twe tèt-li* /s/he killed head-her/his/ 's/he killed her/himself' or Wolof *mu rey boppam* /s/he kill head-her/his/ 'id.' with Kriyol *i mata si kabesa* 'id.' (With *laba* 'wash' *kurpu* 'body' is used as a 'reflexive': *omi na laba kurpu* 'the man is washing (himself)'). As a reflexive anaphor, [POSS *kabesa*] is subject to the ordinary 'binding' conditions, so that **no mata si kabesa* or **Jon misti mata nya kabesa* or **si kabesa mata Jon* are just as bad as *'we killed himself' or *'John wants to kill myself' or *'himself killed John'. The reasons for this have been amply analysed, and it is not necessary for me to repeat them here (see, e.g., Pollard & Sag 1983).

The peculiarity of Kriyol — and, I suppose, of all languages using similar reflexive expressions — is that *kabesa* is a noun, i.e. an item with an independent meaning. Depending on the verb's meaning, ambiguities may therefore arise. For example, (113) can meaningfully be interpreted as 'I saw my head in the mirror', in which case *n oja bu kabesa na spiju* 'I saw your head in the mirror' steps in as a perfectly acceptable expression. Likewise, there is no syntactic reason why *si* in (111) or (112) could not refer to some other entity than the leech or 'everybody'. Although finding the possibility far-fetched, native speakers are forced to agree that

it exists, insofar as biting a head or knowing about a head must be seen as making sense, literally or metaphorically.⁴⁷ One is then led to wonder whether even such apparently clear-cut cases as **i mata nya kabesa* are not simply due to the fact that [head'] is not a proper meaning for the object of [kill'].⁴⁸ If it is so, and descriptive simplicity would have it to be so, then Kriyol grammar does not include reflexive anaphors like Portuguese *se* or English [X-self].⁴⁹ What it has is a possessed NP, [POSS kabesa], where the possessive specifier behaves like an ordinary pronominal as far as coreference is concerned, and the head-noun can a priori be assigned either a grammaticalized 'self' meaning devoid of worldly reference (see the SELF theorem in Keenan 1988); or it can be assigned its full meaning of 'head'.⁵⁰ Depending on the relative probability of these assignments, itself a function of the verb's meaning, language routines, etc.,⁵¹ a 'simulation' of reflexive anaphoricity is then achieved.

The relation of possession to reflexivity was then made clear. It becomes even clearer when the following examples are introduced:

- (114) *Kada kin sibi di sil.* (I)
 every who know of his
 'Everybody knows about their business.'
- (115) *Lebri sibi kuma coka ma sil jiru.* (I)
 hare know KUMA partridge more his smart
 'The hare knows the partridge to be smarter than him(self).'

Sil (plural *selis*) is part of a paradigm of possessive pronouns which consists simply of the oblique pronouns preceded by *di* 'of' (e.g. *es i di mi* 'This is mine'). Although formally PPs, these expressions behave like NPs as shown by (114) — also *ka bu sibi di mi* lit. 'Don't know about what's mine', i.e. 'Don't meddle in my business' — or the last example but one where *di mi* (similarly *di bo*, *di nos*, etc.) has the function of a noun predicate. This suggests that an exocentric rule like the following should be added to the list of non lexical ID rules:

- (116) NP → PP [PFORM *di*]

That is, an argumental or predicative NP may immediately dominate a PP, provided the head of the latter is *di* 'of'.⁵² Only in comparative constructions (for which see Chapter 5) can *sil* appear without a preceding *di*.

In contrast to the items we met so far, *sil/selis* is indeed a reflexive anaphor as shown by the following grammaticality pattern:⁵³

- (117) *Es i omi ku n kontu u del /*di sil.* (I)
 this is man that I tell you of+him/*of+himself
 'This is the man I told you about (??him/*himself).'

Sil/selis is bound within the clause that contains it, insofar as the said clause constitutes an obstacle to feature transmission, which is the case for the relative clause of (117), but not for the complement clause of (115). I will return to these issues. Meanwhile, the evidence justifies our assigning a reflexive (RE) foot feature to **sil/selis**, so that (114) may be given the following structure:

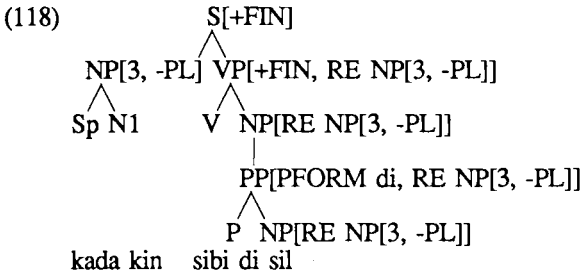

The RE value for **sil** is transmitted up to VP by the Foot Feature Principle (FFP); agreement with the subject of the VP is assured by the Control Agreement Principle (CAP). An alternative way of executing the same idea is by pairing parallel syntactic and semantic representations where the antecedent and the reflexive occupy two and one position respectively. The CAP and the FFP then become well-formation principles for the interface — which they already are in a way.

Then, Kriyol does have a reflexive anaphor after all. Yet, one with distinctive characters. Only third person expressions may serve as antecedents.⁵⁴ Moreover, in contradistinction to ‘himself’ and similar items, it implies that the antecedent (always animate) is in possession of some indefinite conjunct, perhaps best translated as ‘the own’ as opposed to ‘the self’. Minimal contrasts can thus be observed where both **di sil** and **si kabesa** may occur, as below:

- (119) (a) I ta papyá senpri di sil.
 he A speak always of his
 ‘He’s always talking about his own affairs.’
 (b) I ta papyá senpri di si kabesa.
 he A speak always of his head
 ‘He’s always talking about himself.’

As (115) suggests, however, possessivity might well be a lexical attribute of **di** ‘of’ rather than of **sil** itself. In (115), **sil** is used instead of **el** — equally grammatical — in order apparently to disambiguate the pronoun’s reference; **sil** forces the interpretation that the partridge is smarter than the hare, while she might be understood to be smarter than someone else had **el** been employed. No possessive nuance is perceptible.⁵⁵ A partial lexical entry of **sil/selis** may thus look as follows:

- (120) sil/selis
 {<PRO +> <RE +> <PER 3> <PL ⇄> <CASE OBL>}
 Syntax: [N_p [pp PFORM di [NP—]]] ∨ [VP[COMPAR][NP—]]

Note that the comparative operator **ma(s)** designated as VP[COMPAR] in (120) subcategorizes for oblique pronouns (see Chapter 5).

4.7.4. The reciprocal

The Kriyol way of expressing reciprocity is with the complex expression **un utru** ‘one (an)other’. The anaphoric character of **un utru** is clearly seen in the third person where there is a contrast between **e oja un utru** ‘they saw each other’ and **e oja elis** ‘they saw them’ with obligatory disjunct reference in Kriyol as well as in English. In the first and second persons, on the other hand, **no na oja un utru** ‘we’ll see each other’, e.g., can be freely replaced with **no na oja no** ‘?we’ll see us’ (see P. *vamos ver-nos* ‘we’ll see each other’ vs. *viram-se* ‘they saw each other’). It seems, however, that Kriyol makes much more use of **un utru** than Portuguese does of *um outro*, for which the simple reflexive will serve as long as no ambiguity arises. There might be some measure of substratal influence here, since Reciprocal is one of the categories verbal morphology regularly provides for in Atlantic languages (see Manjaku *fiër* ‘to need’ vs. *fiërëlar* ‘to need each other’ or Wolof *sedda* ‘give a share’ vs. *seddante* ‘give each other a share’).

As a rightful anaphor, **un utru** can only appear as the argument of some functor, verb or preposition, never as a subject (***un utru oja elis** ‘*each other saw them’), as a correlate of the fact that it must itself be in the domain of some (plural) subject in a broad sense — note that **e kunpra foto di un utru** seems to have the same status as ‘they bought each other’s pictures’, i.e. grammatical but somewhat bewildering to lay speakers. As the last example shows, incidentally, Kriyol **un utru** also differs from its Portuguese etymon as to the degree to which it is lexicalized. Both components of *um outro* can be separated as in, e.g., *falaram um com o outro* ‘they talked with each other’ (lit. ‘each with the other’). This would be rendered in Kriyol as **e papya ku un utru**, where the complex **ku un utru** makes up one phonological word [ku’ɲutru]. Note, however, that the nasal in **un** is velarized as is normal in word-final position. This is why I finally discarded the option of writing **un utru** as one word, **unutru**, as it would make it difficult to account for the phonological treatment of intervocalic /n/. That **un utru** should nevertheless be considered one lexical item meaning ‘reciprocal anaphor’ is in no way impeded by this purely practical decision (concordant, by the way, with the official orthographic standard).

4.7.5. *Quantifying pronouns*

Quantifying pronouns are items whose logical translation is that of NPs, viz. $\lambda P \exists x [E'(x) \ \& \ P\{x}]$ (see Gazdar et al. 1985:188), where E' is the meaning of the name of an entity. Their peculiarity vis-à-vis ordinary NPs is that E' cannot be named precisely, but must stand for a whole class of beings over which the expression quantifies, saying that the intended entity x belongs to that class, but revealing nothing more as to its identity which has to be inferred from context or remain unknown. They are therefore both quantifiers and pronominals. In languages like English or Portuguese — or Kriyol — there are only two classes, humans represented by 'somebody' (P. *alguem*), and non-humans represented by 'something' (P. *algo, alguma coisa*).⁵⁶ Additional semantic elements are negation ('nobody'), exhaustivity ('everybody'), etc.

Kriyol quantifying pronouns are easily listed. A complete list, not taking 'decreolized' items into account, will include **algin** 'somebody', **ningin** 'nobody', **kada kin** 'everybody', **kin** 'whoever', **ke** 'whatever', **un kusa** 'something', **tudu** 'everything', **nada** 'nothing'. A few comments can be made.

Firstly, it must be noticed that **algin** functions both as a genuine quantifying pronoun (e.g. **algin bin awonti** 'somebody came yesterday') and as a noun meaning 'person' as in the following example:

- (121) Ay, ay, nya algin di korson, perta n mas, perta n ku
 ah ah my person of heart tighten me more tighten me with
 forsa. (HGCS)
 strength
 'Ah, ah, my darling, hold me tighter, hold me strong.'

True, 'person' is not very different itself from a quantifying pronoun, so that **algin bin awonti** 'somebody came yesterday' and **un algin bin awonti** 'a person came yesterday' are practically interchangeable. More to the point, perhaps, an interesting parallel may be noted between Kriyol and the substrate languages which have no special lexical items for quantifying pronouns, but use generic nouns like 'person' or 'thing' for the function (e.g. Manjaku *nyaan* 'person, somebody'). Portuguese, by contrast, does not allow constructions like **um alguem*, **o meu alguem*, and so forth.

Kriyol and the substrate languages, especially the Atlantic ones, diverge however as far as negative quantifying pronouns are concerned. The latter are strict followers of the 'one NEG per clause' principle, with the negation bearing on the head of the clause (e.g. Manjaku *nyaan tsēpats* /person leave+NEG/ 'nobody left'). On the contrary, multiple negation is the rule in Kriyol where one must say, e.g., **ningin ka sta li** 'Nobody isn't here', **n ka oja nada** 'I didn't see nothing', and so forth.⁵⁷ Note the generalization with respect to Portuguese which does have *não* vi

nada 'I didn't see nothing', but rejects **ninguem não está aqui* (OK *ninguem está aqui* 'nobody is here'). Multiple negation becomes really interesting when it turns into negation propagation or negative concord (see Labov 1968; Carden 1973) as in these examples:

- (122) Kil rey ka misti pa ningin kasa l. (I)
 that king NEG want for nobody marry her
 'The king didn't want anybody to marry her.'
- (123) I ka bon bay byas sin bu ka sibi kuma kaminyu sta
 it NEG good go trip without you NEG know KUMA path be
 linpu. (MC)
 clean
 'It isn't good to go away on a trip without knowing whether the
 omens are favourable.'
- (124) Nin i ka fala ningin nada. (I)
 not-even he NEG say nobody nothing
 'He didn't even say anything to anybody.'
- (125) E dus jintis bin pa mi sin nada n ka fasi elis.
 this two people+PL come for me without nothing I NEG do them
 'These two guys came out looking for me, and I haven't done them
 a thing.' (MSLK)

Two entwined phenomena are illustrated by these sentences. One is NEG-prop(agation) proper, the other some sort of quantifier floating, which is not restricted to negative items as shown by the following:

- (126) Tudu n tene. (HGGN)
 everything I have
 'I've got everything.'

How are we to account for them? A good example to begin with is (123). Let us assume *sin* 'without' to be a complementizer meaning roughly 'and-not' (&-NEG). The syntactic tree for *sin bu ka sibi* will then be

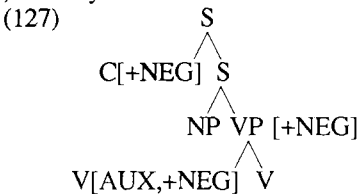

Notice that, given the local character of the Head Feature Convention, there is no syntactic way of warranting that the NEG values for the complementizer and the VP will match, since they are not sister nodes. Moreover, C and VP do not stand in a functor-argument relationship, so that the CAP is irrelevant. Even in the minimal sentence *bu ka sibi*, there is clearly no 'NEG agreement' between the VP

and the subject (although there might be as we shall see), and NEG does not spread higher up than VP. Yet, the presence of a negation in the VP is clearly a consequence of the use of *sin*. In other words, *ka* has no independent value here, and it is this fact that we want to capture. In order to do that, let us draw a logico-semantic representation corresponding to (127):

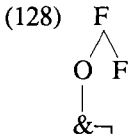

to be read as, *sin bu ka sibi* is a formula (F) consisting of a sentential operator whose meaning is $\&\neg$ or and-NEG, and a formula in the scope of this operator. What we need do now is pairing both representations in order to bring the NEG-prop process to light:

(129)	C	NP	VNEG	V	SYNTAX
	<i>sin</i>	<i>bu</i>	<i>ka</i>	<i>sibi</i>	
	x	x	x	x	INTERFACE
	x	x	x	x	
	$\&\neg$	<i>bu</i>		<i>sibi</i>	
	O	Arg		Pred	SEMANTICS

NEG-prop is now seen as an interface phenomenon, a kind of autosegmental spreading from one dominant position to accessible positions. But how do we define an accessible position in order to constrain the process? Let us turn to (124), *nin i ka fala ningin nada*, which we can strip of its opening *nin* to make VP the first propagation site. Here is a simplified logico-semantic translation of this version of (124):

(130) \neg [i fala x y] (human x) (-human y)

to be read in logicese, 'It is not the case that he told some human some thing'. The formula encloses three accessible positions. Two of them, the inner arguments of the predicate, have an obvious feature in common: they are quantifiers, and they have it in common with NEG too, inasmuch as negation is a variety of quantification ('no X' as opposed to 'some x' as opposed to 'all x'). What about the third position, that bearing directly on the head of the predicate? Consider this is a position where items all having the [AUX] feature are generated, items which modify the VP as they let it be known that it either is not the case (*ka*) or is the case in a certain fashion (*na*, *ta*, and the aspectual interpretation of finiteness —

see Chapter 2). Therefore, this is also a quantifying syntactic position which is naturally accessible to the NEG operator of the semantic plane.⁵⁸ NEG-prop can now be given a general definition:

- (131) NEG-prop (definition): In the syntax-semantics interface, a semantic operator having ‘negation’ as (part of) its meaning may link to syntactic positions whose semantic counterparts have ‘quantification’ as part of their meanings.

As already mentioned, the ultimate rationale for this definition and for NEG-prop as a process is that negation is quantification.⁵⁹

A debatable word in (131) is ‘may’ which suggests that NEG-prop is an optional process. Actually, (124) shows that this is not always, nay seldom true, insofar as the negation must propagate to the V[AUX] position, as well as to both complement quantifiers — **i fala ningin nada* being just as bad as **i ka fala algin un kusa* (as distinct from *i ka fala un algin un kusa* ‘s/he didn’t tell a certain thing to a certain person’). The only case of apparent optionality is with a subject quantifier in an embedded sentence as in the example in footnote 57. Now, an alternation such as *algin ka V* vs. *ningin ka V* might well not be NEG-prop at all, but rather an instance of verb-subject agreement under the CAP, whereby the correct statement would be that quantifier subjects optionally agree for negativity with negated predicates.⁶⁰ A possible confirmation is (122), *kil rey ka misti pa ningin kasa I* ‘The king didn’t want anybody to marry her’. Here, the (optional) use of *ningin* ‘nobody’ instead of *algin* ‘somebody’ is an effect of NEG-prop from the higher negation — which also shows that NEG-prop is not bounded within one clause (see Chapter 5). That means that the negative value of *ningin* is independent from the polarity of the predicate it is the subject of. As a consequence, while *ningin ka kasa I* plainly means ‘Nobody married her’, the multiply negated version of (122), *kil rey ka misti pa ningin ka kasa-I*, is most often interpreted as ‘The king didn’t want for anybody not to marry her’, with two independent negations not provided by negative agreement. (It is fair to add, however, that this kind of sentence often causes a lot of bewilderment, and I am not too sure to what extent the informants’ judgments ought to be trusted.)

It is interesting, in any case, to contrast (122) with (125), *e dus jintis bin pa mi sin nada n ka fasi elis* ‘These two guys came out looking for me, and I haven’t done them a thing’, as the latter shows that the relative (in)dependence of negations has nothing to do with linear precedence. Although *nada* ‘nothing’ precedes *ka*, all negations from *sin* downward are stations along a path of NEG-prop. This is

because (125), in addition to being an instance of NEG-prop, also illustrates a different phenomenon, viz. quantifier floating, to use the standard, albeit theory-loaded, label for the thing.

Quantifier floating is common in Kriyol, affecting both negative quantifiers and **tudu** as in (126) or in the following:

- (132) E fididu jinjirba tudu i kaba. (J)
 they be-slit gums all it be-finished
 'Then they all had their gums tattooed.'⁶¹

Despite its position, **tudu** obviously replicates **e** functionally.⁶² Here is, I think, another domain where an autolexical treatment proves especially revealing, as compared with the classical movement account. Earlier, it was assumed that Kriyol sentences are provided with a prefixed or suffixed position where material with a special discourse-functional force (e.g. non-A pronouns) can be inserted. It is therefore natural to assume further that **nada** in (125) or **tudu** in (132) occupy this position. This assigns the following syntactic structure to **sin nada n ka fasi elis**:

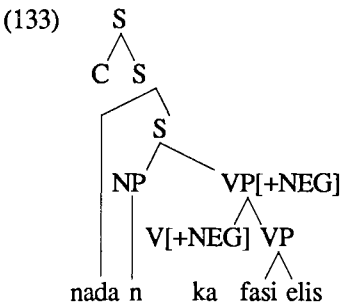

To be a rightful GPSG tree, (133) should include a SLASH [NP QUANT] feature from the lowest S down, and a null complement under VP marked NP[QUANT, NULL]/NP[QUANT]. But consider the semantic analysis of the same expression:

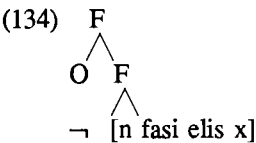

(X spells out as **un kusa**, ¬x as **nada**, given a [-human] feature on x.) Let us now pair them in the usual way:

(135)	nada	n	ka	fasi	elis	SYNTAX
	x	x	x	x	x	INTERFACE
	x	x		x	x	
	¬	n	fasi	elis	x	SEMANTICS

A simple principle will constrain the operations of the interface:

- (136) Quantifier linking principle (QLF): A quantifier may be simultaneously linked to an argument position in the semantic input and to one of the special adjoined positions in the syntactic input.

The ‘meeting’ of the quantifier and the negation in the special position is a consequence of NEG-prop as defined above. Slash notation or any residue of movement are thus made unnecessary, since the function of *nada* with respect to the predicate can be directly read off a representation like (135). Also note that the popularity, if I may say so, of such constructions across languages is nicely accounted for, insofar as they realize a complete isomorphism between the syntactic, logico-semantic and discourse-functional dimensions.

Little remains to be said on the subject of quantifying pronouns. Examples of the pronominal use of *kin* can be found in (87) and (114) (interrogative *kin* will be studied in Chapter 6). Here is another:

- (137) *Kin kungsi si nomi el ku na bin kasa l.* (J)
 who know her name he that A and-then marry her
 ‘Whoever knows her name will be the one to marry her.’

As it appears, *kin* can be the subject of a clause. It may also be part of a focalized construction (see Chapter 6) as in (87) or, obligatorily then, when its function is being an object.⁶³ Semantically, *kin* is distinct from *algin* in that the latter means ‘some (potentially identifiable) person’, whereas *kin* means ‘any person’ satisfying the conditions set by the predicate. Hence the unique association of *kin* with *kada* ‘each’, *kada kin*, to signify ‘everybody’. (*Kada algin* is possible, but it means ‘each person’, with an individual rather than set interpretation; with the same meanings, Portuguese has *cada um* and *cada pessoa* respectively.) *Ke* behaves like *kin*, except for being obligatorily focalized.

I close this section with an example showing how adjunct quantifier pronouns not realized as lexical items in Kriyol can nevertheless be constructed (the quasi-pronominal character of *kaw* ‘place’ was underlined in Chapter 2):

- (138) *I ka para na nin un kaw.* (J)
 he NEG stop in not-even a place
 ‘He never stopped anywhere.’

4.8. Special types of NP II: nominal infinitives

In Chapter 2, we examined non finite predicates fulfilling argumental functions, and we came to the conclusion that they included an identified, albeit syntactically unrealized, subject. We are dealing now with a different type of non finite predicates, where no specific or identifiable subject can be reconstructed. A few examples will illustrate:

- (139) Na kaw di fidi jinjirba. (J)
 in place of slit gums
 'In the place where gums are tattooed.'
- (140) Faka di atorna ka ta moku. (EG)
 knife of avenge NEG A blunt
 'The knife of vengeance is never blunt.'
- (141) Kunbera di magru ka ta obidu na kaw di fola baka. (TM)
 talk of skinny NEG A be-heard in place of joint cow
 'The skinny man's voice is not heard where cow meat is jointed.'
- (142) Ncala i falta di sibi ku si nega punta pa sibi. (MJPB)
 N. he lack of know with his refuse ask for know
 'Ncala remained uninformed because of his refusal to ask questions in order to know.'
- (143) Na es kunpra polvora la ku kunbera kumsa nel. (K)
 in this buy powder there that talk begin in+it
 'It was at the occasion of this powder purchase that the talks began.'

The first three examples are clearest. In neither of them is the act of tattooing gums or of avenging oneself or of jointing cattle predicated of any specific agent. Nor could they be considering that (140) and (141) are proverbs, and that places such as that described by (139) are used by indefinite numbers of people, generation after generation. Yet, *fidi jinjirba*, *torna*, and *folo baka* are indubitably predicates headed by verbs exhibiting the subcategorization features which befit them. Moreover, the syntax and semantics of such expressions are rather constant. They consist of an NP dominating a PP headed by *di* 'of' with a VP as its complement. The NP denotes a place, or a means, or an instrument, and the VP describes what is done in the place, or by the means, or with the instrument, not in any particular occasion, but as an element of the definition of the NP.⁶⁴

It seems therefore we are dealing with a generalization of rule (116) according to which an NP may immediately dominate a PP provided the latter is headed by *di*. Now we have a rule stating that an NP may immediately dominate a subjectless, non finite VP:

- (144) NP → VP[-SUBJ, -FIN]

Rule (144) will licence the following tree for, e.g., **kaw di fidi jinjirba** 'gum tattooing place':

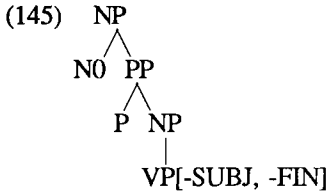

This, rather than having PP immediately dominate VP, provides for the fact that **fidi jinjirba** does have an NP-type denotation, just like its English equivalent 'gum tattooing'. The overall denotation of the NP **kaw di fidi jinjirba** is then the union of this NP's meaning (some action) with the meaning of the head.

Rule (144) also takes care of examples (142) and (143). The analysis of **na es kunpra polvora** in the latter is straightforward:

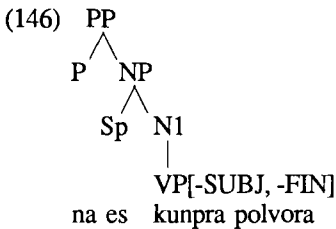

The predicate [buy powder] is thus given an NP-type denotation ('powder purchase') at the same time that it is specified by demonstrative **es** as referring to an occasion of the activity in question. Again, this is something of a ready-made pattern, which is used whenever one wishes to express the fact that an occurrence, or a set of occurrences, of a generic action is somehow associated with the description of some state of affairs.

Sentence (142) is another instance of the same pattern, with P spelt out as **ku** and Sp as **si**. It might be thought to be different insofar as the action 'refuse to ask...' seems indeed to be predicated of 'him' through the possessive. Remark, however, that no specific instance where 'he' is said to have refused is implied. In other words, (142) is not (at least not entirely) synonymous with, e.g., 'Because he refused...' (**pabya i nega...**). Rather, it conveys the somewhat more complex meaning that 'his' eventual ignorance is associated with a characteristic of his which can be described with the NP-type phrase 'refusal to...', but is not due to any particular instance of 'refusing to' that one might point at. **Ku** 'with' accurately expresses this relationship.

Nominal infinitive predicates only occur as complements to prepositions, i.e. as adjuncts to clauses or within NPs. This is understandable insofar as those are positions where no control relationship may hold between a main finite verb and the infinitive, as opposed to cases where the infinitive is the subject or the object of the main verb (see Chapter 2 and 5). Those are the only positions, in other words, where the infinitive need not have a specified logical subject and may behave as a mere name for the process rather than as a description of an instance of the process. (There is in fact another position where these conditions obtain, for which see next section.)

In fact, whole sentences can be reified in this way as the following proverb illustrates:

- (147) Fiju di si-n-sibi ka ta maradu di kanpainya. (TM)
 son of if-I-know NEG A be-tied of bell
 'They didn't tie a bell on the son of had-I-known.'

Such things are of course rare in common talk.

4.9. Relative clauses

Being functionally equivalent to attributive adjective phrases, relative clauses (RCs) fully belong to the study of NPs. On the other hand, they also exhibit many UDC characters, which makes the end of the present chapter the logical place to deal with them, just before we turn to the study of complex sentences.⁶⁵ Consider first the following examples:

- (148) N misti panya dus lagartus ku ngana n. (FJDM)
 I want catch two crocodiles that deceive me
 'I want to catch two scoundrels who deceived me.'
- (149) Es ku i planu ku ciganta fulas Kansala. (K)
 this that it plan thatarrive+CAUSE Fulas Kansala
 '(It is) this that is the plan which brought the Fulas to Kansala.'
- (150) Naw i ka kila ku n pirdinti. (DR)
 no it NEG that that I lose
 'No, it isn't that that I lost.'
- (151) Bu jubi es palabras kal ku bu dibi koloka l. (I)
 you look this words which that you must place it
 'You look at these words (and see) which ones you must place.'
- (152) Kin ku si mon seku purneru el ku na fika na kasa. (J)
 who that his hand dry first he that A stay in house
 'He whose hand dries first will stay at home.'
- (153) Es i omi ku n kontu del. (I)
 this it man that I tel you of+him
 'This is the man I told you about.'

- (154) Nya tabanka i yera un tabanka ku kolonus sta ba nel. (I)
 my village it be+PAST a village that colonizers be PAST in+it
 'My village used to be a village where colonizers lived.'
- (155) Abó i úniku fiju ku n sobra kel. (HGTM)
 you it only son that I remain with+him
 'You're the only son I've got left.'

They all show an identical *ku* morpheme demarcating the boundary between the NP's head and the RC, no matter what the function of the head with respect to the RC may be — a subject in the first two examples, an object in the next two ones, an adjunct in the last three. This is a strong indication that *ku* is not a relative pronoun like English 'who', 'which', etc. (see Gazdar et al. 1985:153ff.), but rather a realization of Comp. Note that, although *ku* seems to function as a subject in (148), it does not in (149) where the third person subject pronoun is fully spelt out (at least in writing — see below). I will therefore assume that (149) faithfully represents the syntactic make-up of this sort of sentences, whereas (148) embodies morphophonological processes to be examined in a moment. Kriyol RCs can thus be described with the following non lexical ID rule, whose particulars will be explained as we progress:

- (156) NP → NP, S[COMP *ku*]

where *ku* appears as the specific form taken by the COMP feature when it bears on RCs, to be found nowhere else (see Chapter 5).⁶⁶ This form deserves a few comments, by the way, before we turn to a scrutiny of the various types of RCs.

Indeed, the phonetic realization (and spontaneous graphic notation) of [COMP *ku*] is quite variable, being [ku], [ki], [ke], [kë], or even [k].⁶⁷ This variation has nothing to do, it seems, with the grammatical function of the head — e.g., [ki] is no more 'subject' than [ku] or [ku] more 'object' than [ki] — it is an inherent variation depending on such factors as vocalic harmony, rate of speech, individual habits, and so forth. It is not my task to investigate further, so I will content myself with choosing /ku/ as the representative realization for [COMP *ku*].⁶⁸

Given rule (156), the NP [dus lagartus ku ngana n] in (148) will then be assigned a syntactic structure like the following:

- (157)
- ```

 NP
 / \
 NP S [COMP ku]
 / \ / \
 Sp N1 ku S
 / \
 NP VP
 |
 e

```

The obligatory coreference of **dus lagartus** 'two scoundrels' with **e** 'they' is guaranteed by unification. Consider indeed the analysis tree for (157):

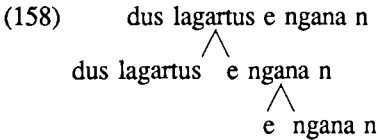

Only with **e** having exactly the same denotation as **dus lagartus** can both expressions be unified into one, since [e ngana n] would not say anything about [dus lagartus] otherwise. Also observe how (158) paralleled with (157) makes it evident that **ku** is no more than a syntactic 'linker' which need not have a semantic representation. **E** 'they', on the other hand, has no phonological representation, so we are led to assume an optional process in the syntax-phonology interface which can be represented as follows:

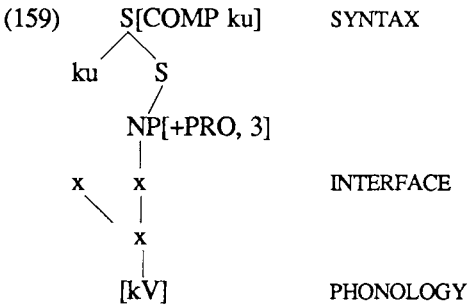

with **V** ranging over {[u],[i],[e],[ë],∅}. The plausibility of (159) is demonstrated by (i) examples such as (149) which represent a possible, albeit rare, realization where **ku** and the third person pronoun are articulated separately (implying a slow, deliberate speech style); (ii) the fact that non third person pronouns which do not consist of one vowel are always realized (**amí ku n...** 'I who...', **anós ku no...** 'We who...', and so forth), to the exception of **bu** 'you' which may merge with **ku** to produce [ku:] or [ku] (**omi ku bu oja** ['omi ku o'ja] 'The man you saw').<sup>69</sup> As the latter case shows, the function of the pronoun being amalgamated with **ku** plays no role in the process. Only phonological factors enter the picture, here the fact that [b] is a candidate for fricativization and deletion in a variety of environments (see Introduction).

Constructions where the NP's head is the object of the RC's verb, such as (150), are easily handled using the SLASH device:



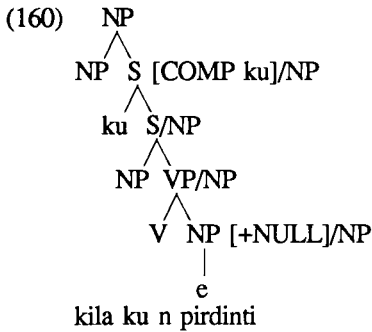

It is now apparent why we had to devise rule (156) as we did, allowing NP to immediately dominate NP and S, rather than simply adopting Gazdar et al.'s rule for RCs, viz. N1 → H, S[+R] (1985:248). Indeed, the absence of relative pronouns in Kriyol entails that a subject or object head has no instantiation within the RC, so that all RCs are interpreted according to (158), i.e. by directly unifying an NP and an S within an overarching NP. Using Gazdar et al.'s rule would then have the undesirable technical consequence that we would end with a VP lacking an N1 (VP/N1), but VP → V, N1 is not a conceivable rule given the standard X-bar format.<sup>70</sup>

'Gap' constructions like (160) are the normal state of affairs for RCs with object heads, **\*i ka kila ku n pirdinti l** or equivalents with resumptive pronouns being generally rejected. Interpreting SLASH notations in terms of parallel representations, this means that two connected positions correspond to the head in the semantic plane ([kila [n pirdinti kila]]), but only one in the syntax. One nevertheless find scattered examples like (151) where the head is resumed by a third person pronoun in the semantically assigned position within the RC. Whether there is a genuine variation here, or this is a quirk of performance, I do not know. The possibility exists, at any rate.

With adjunct heads, it is in fact the only possibility, as shown by examples (152) to (155). The head must be resumed in the RC, either by a possessive specifier as in (152), or by the third person singular pronoun as in the other examples. Resumptive pronouns, let it be said in passing, are easily and elegantly accommodated in the parallel representations framework. They are simply gap-like elements which project a position into the morphological plane; hence, they must be realized, but they are not semantically autonomous. Note further that, given the syntactic make-up of Kriyol, resumption is the only option for adjunct (or noun complement) heads. Indeed, preposition stranding is totally out of the question (e.g., **\*\*es i omi ku kontu u di**), probably because Kriyol Ps are morphological clitics. Pied-piping, on the other hand, is equally excluded, this time because Kriyol

simply has no relative pronouns to allow it (\*\*es i omi di ku n kontu — conversely, the impossibility of pied-piping confirms **ku**'s identity as a complementizer which cannot be the complement of a preposition).<sup>71</sup> A resumptive pronoun (in the sense just defined) governed by a preposition in its syntactic location is then the only way that the head noun can be represented within the RC. I have one example where **ku** seems to be treated as a relative pronoun:

- (161) I dismanca saku dentru di ki Lwis puy ba nel si fiju. (EG)  
 he destroy sack inside of which L. put PAST in+it his son  
 'He tore the sack within which Lwis had put his son.'

This, I think, is better analysed as a case of borrowing a chunk of Portuguese grammar (*dentro de que...*) and laying it along with Kriyol grammar (note the use of resumption all the same).

For the sake of explicitness, I give here the syntactic tree of, e.g., **fiju ku n sobra kel** 'the son I stayed with' (see 155):

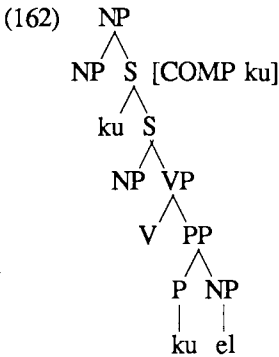

The pronoun's coreference with the head noun gets fixed in the syntax-semantic interface, assuming the semantics associated with (162) to be represented by an analysis tree similar to (158):

- (163) fiju n sobra ku el = fiju  
 fiju / \ n sobra ku el = fiju

Recall the informal semantic definition of control in Gazdar et al., 'The first NP argument to combine with a functor in which a VP occurs is the (semantic) controller of that VP' (1985:202). Therefore, **fiju**, more generally the head of the NP containing an RC, must be the semantic controller of the pronoun in the RC's VP. Of course, control is a syntax-semantics interface phenomenon. The amalgamation of **ku** and **el** into **kel**, on the other hand, is a thing to be dealt with in the syntax-morphology interface.

Finally, it must be noted that the occurrence of a resumptive pronoun in the RC depends from the availability of a semantically adequate PP. Take, for instance, the following:

- (164) Bo ka oja manera ku bo puy n n pirdi kurida. (FJGK)  
 you[PL] NEG see manner that you[PL] put me I lose race  
 'You didn't see how you made me lose the race.'

Here, the head noun *manera* has no instantiation in the RC, simply because, given the lexical resources of the language, no combination of a preposition and a pronoun will adequately refer back to it.<sup>72</sup> Yet, the meaning of the expression is perfectly clear, which must draw our attention to the fact that the use of resumptive pronouns in RCs is indeed an interface phenomenon, a result of the interaction between syntax and semantics, not something that is absolutely necessary for understanding. (As a matter of fact, sentences like *es i omi ku n konta u* 'This is the man I told you' are heard.)

A few facts remain to be outlined concerning RCs. Firstly, the possibility seems to exist for [COMP *ku*] not to be realized. As I only found one example of this, and it is not a domain where the native speakers' intuitions can be easily checked, I will refrain from drawing any conclusions. Here is the example:

- (165) Omi fala jintis kuma i tene punba na kanta sabi. (J)  
 man say people KUMA he have dove A sing sweet  
 'The man told the people he had a dove that sang beautifully.'

Secondly, there is an interesting construction in Kriyol which combines nominal infinitives with RCs:

- (166) Kuri ku i na kuri sin ka linpu. (FJGK)  
 run that i A run so NEG clean  
 'The way he's running is not fair.'
- (167) Kunpra ku i kunpra karu son i bindi l janan. (I)  
 buy that he buy car only he sell it at-once  
 'No sooner had he bought a car than he sold it.'
- (168) Fulas pa tudu fasi ku e fasi nunca e ka konsigi ciga  
 Fulas for all do that they do never they NEG manage reach  
 Kansala. (K)  
 K.  
 'The Fulas, no matter what they did, never managed to reach  
 Kansala.'
- (169) Tudu beju ku bu na beju bu ka ta mati bajudesa di bu  
 all old that you A old you NEG A watch maidenhead of your  
 mame. (TM)  
 mother  
 'No matter how old you get, you will never witness your mother's  
 maidenhead.'

Although they look superficially similar to the so-called 'predicate clefting' constructions one encounters in, e.g., Haitian (see Lefebvre 1990), the Kriyol constructions are in fact very different. For one, they exhibit a quite distinct range of meanings, neither intensification nor cause, but only one of three things, exemplified by (166), (167) and (168-169) respectively, viz. 'the way x VP', 'as soon as x VP', or 'no matter how x VP'. Secondly, given such meanings and the syntax of the expressions, there is little doubt that we are dealing here with NPs headed by nominal infinitives or non predicative adjectives. Here is then another environment where an infinitive stays outside the control domain of a higher verb and need not have a logical subject.

The nominal character of the infinitive is at its clearest in the case represented by (168). First of all, one must realize this is almost a fixed expression in that, apart from *fasi* 'to do', only *tarda* 'to take a long time' (see above) is normally used in the context. Nevertheless, it is possible to have informants accept sentences like (168) with intransitive verbs, or even transitive ones constructed as in (167), although I must say in all fairness that none such was ever presented to me spontaneously, neither did I find one in the texts available to me. I leave it to the readers to decide on the importance of this point according to their own methodological credos. On the other hand, (169) is a proverb constructed according to what Montenegro calls a *fórmula*, that is one of a number of fixed patterns, here [(NP<sub>i</sub>) *tudu* Adj/V[-FIN] *ku* Pro<sub>i</sub> Adj[+Pred]/V Pro<sub>i</sub> NEG VP] (see Montenegro 1990:10-11).<sup>73</sup>

On the semantic side, the concessive meaning results compositionally from (i) the inherent meaning of *tudu* 'all' which is obligatorily present (whereas *pa* is optional); (ii) the association with a verbal replica of the head in the RC; (iii) the following clause explaining what did or will happen to its subject in spite of his/her/their activity as described by the verb of the RC. The fact that the nominal head and the RC's verbal head must be replicas of each other is crucial. It has the effect of closing the process in on itself, so that [NP *fasi ku e fasi*] 'the doing that they did' is interpreted as a name whose extension is one instance of the activity denoted by the successively nominal and verbal lexical item, and attributed to a given subject through the RC.<sup>74</sup> *Tudu*, then, quantifies over a series of such instances, contributing plurality and repetition to the meaning.<sup>75</sup> Finally, this set of activity instances is contraposed with the description of some state of affairs, with the inference that the said state of affairs would not be the case had the activity whose numerous instances have just been posited gone through. This 'in spite of' implication is often enhanced by the negative character of the description, as in (168) and (169) — always in the latter case (see above).

On the formal side, on the other hand, a number of issues have to be dealt with. One is already provided for, viz. the ‘nominalization’ issue, by rule (144), associated with rule (156) for RCs. Both rules will licence the following tree for, e.g., **tudu fasi ku e fasi** (see (168)):

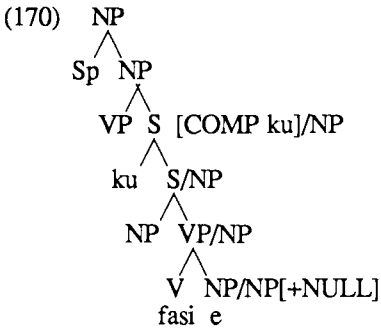

Subcategorization is a trickier problem, though. There is no difficulty with **fasi**, a transitive verb selecting NP complements. But what about **tarda**, an auxiliary verb selecting VP complements, or predicative adjectives which do not select any complement at all? What grammatical function may nominal **beju** fulfill with respect to the RC headed by predicative **beju** in (169)?

The heart of the matter seems to be that (170) is not an adequate representation for (169) and analogous expressions insofar as the SLASH feature instantiated on the higher S could not be transmitted down into the VP simply because such a VP as headed by **beju** has no position for an NP (the empty category would not be licensed, in another theoretical dialect). But consider that **tudu fasi** in (168) and (170) is not an ordinary NP like ‘every deed’ or ‘every action’. It is a nominalized VP, meaning there is an inner argument in its denotation. What argument is that? Obviously none other than itself. That is to say, the semantic analysis of **tudu fasi** is something like

(171) (<sub>NP</sub> tudu (<sub>VP</sub> fasi (<sub>NP</sub> tudu (<sub>VP</sub> fasi (<sub>S</sub> ku e fasi))))))

where NP, VP and S are semantic types. Indeed, ‘unfolding’ a relative construction such as (170) on the model of ‘the book I bought’ → ‘I bought the book’ would lead to an infinite recursion (**e fasi tudu fasi ku e fasi tudu fasi...** ‘they did all the doing that they did all the doing...’). In other words, the construction may be viewed as an instance of the not-too-well studied phenomenon known as ‘cognate object’ (e.g. ‘dream a dream’, ‘die an untimely death’, etc.). Since cognate objects are notoriously impervious to transitivity restrictions, no problem need arise any more with intransitive heads such as **beju** or **tarda**. Note further that the notion

matches nicely with the ‘closing in’ of the process mentioned above, so that semantics is satisfied as well.

Example (167) poses a problem, though, since the object position of the verb in the RC is occupied (by **karu**). An interesting observation is that the ‘overt’ object can only follow the second instance of the noun/verb, so that **\*kunpra karu ku i kunpra son...** is ungrammatical. I would therefore suggest that **karu** is in fact the object not of **kunpra** alone but of the whole phrase [kunpra ku i kunpra], with (172) the syntactic structure of (167):

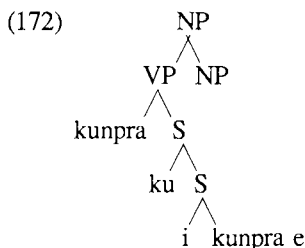

To sum up, all sentences in (166-169) have the same structure where a nominalized VP heads a relative clause whose missing argument is this same VP, hence construed as a cognate object. Three readings are produced according to additional elements in the construction. The concessive reading of (168) and (169) is primarily a function of **tudu** modifying the NP. The ‘as soon as’ meaning of (167) is probably due to **son** ‘only’. The absence of all modifier in (166) is what explains that **kuri ku i na kuri** is understood as synonymous with **manera ku i na kuri** ‘the way he runs, his running thus, etc.’. In (166), the NP **kuri ku i na kuri** is the subject of the VP **ka linpu** ‘(is) not fair’. In the other examples, the corresponding NPs are not so integrated syntactically. Actually, they appear quite analogous with topicalized elements presenting circumstances on the background of which events will be related or judgments will be passed (see Chapter 3 for examples). Since their denotation is not events, but sets of all the (relevant) instances of a given event, NP is an adequate label in every case, syntactically as well as semantically.



## Chapter 5

### The complex sentence

#### 1. Introduction

There are many things under the label ‘complex sentence’. The phenomenon that immediately comes to mind is embedding, i.e. the fact that one sentence, as an expression unit, can comprise several propositions linked to each other in a modification or complementation relationship. That we will study at length. But a sentence can be complex not only by virtue of consisting of several clauses, but also because one or several of its parts occupy positions away from those assigned them by immediate selection principles. By this I’m pointing to topicalized and so-called ‘dislocated’ constructions, questions involving fronting of the WH-word, focalized constructions (intimately connected to the preceding as we shall see), and middle, passive and causative expressions where arguments are somehow shifted from what may be considered their basic positions. A cover-all concept for all those disturbances is ‘mismatch’, i.e. any lack of one-to-one correspondance between the modules that define expressions, specifically the semantic and the syntactic ones. These cases will be discussed in Chapters 6 and 7. In this chapter, we will limit ourselves to the study of sentence embedding, i.e. complementation, a rather intricate domain in Kriyol. The serial verb issue will be taken up in this connexion. Note that only finite complement sentences will be considered here. Complement infinitives in control-type constructions (**n misti bay** ‘I want to go’) are not sentences but VPs, and they were studied in Chapter 2. Some discussion of what constitutes a finite sentence will therefore be in order. Gerundive complements and comparative constructions are included as well.



## 5.2. Complement sentences

Like nominal expressions, complement sentences can be direct arguments of verbal heads ('I think (that) he'll make it'), they can be indirect arguments ('I'm thinking of what he's doing'), or they can be adjuncts expressing various types of relationships ('because', 'if', 'although', etc.). The second kind, the less clear as to its status, will be studied in connexion with indirect questions, of which it seems to be a sub-type. In this section, we will explore, at length, direct complement sentences,<sup>1</sup> and then, more rapidly, adjunct sentences.

Complement sentences in Kriyol must be distinguished according to the semantic class of the verb under which they come. Indeed, whereas Portuguese has only one (direct) complementizer, viz. *que* 'that', Kriyol has two, **pa** and **kuma**. With factive verbs ('want', 'try', etc.), **pa** must be used; with declarative and epistemic verbs ('say', 'know', etc.), **kuma**. In no case can **ku**, the Kriyol reflex of *que*, be used to embed a sentence under another one; its only function is to embed a sentence under a nominal head, as we saw in the preceding chapter.<sup>2</sup>

### 5.2.1. Complement sentences under factive verbs: *pa*

Factive verbs constitute a rather open-ended category whose common feature is that the mental activity they denote is somehow responsible for the ultimate realization of the state of affair denoted by their complement. Here are a few examples:

- (1) N misti pa bu tira n el bariga. (HGTM)  
I want PA you pull me her belly  
'I want you to abort her for me.'
- (2) I fala si omis pa e ribanta l. (MK)  
he tell his men PA they bring-back him  
'He told his men to bring him back.'
- (3) I ka ta permissi n ba pa n papy koretamenti. (I)  
it NEG A allow me PAST PA I speak correctly  
'It hadn't allowed me to speak correctly.'
- (4) Direson disidi gos pa tudu komunikadus ba ta pagadu antis di  
direction decide now PA all announcements BA A be-paid before of  
divulgadu. (RB)  
be-broadcast  
'The direction decided that, from now on, all announcements should  
be paid before being broadcast.'

Two crucial features of these constructions are: (i) verbs embedded with **pa** must have autonomous subjects distinct in reference from the subject of the matrix clause; (ii) they are never marked for aspect, although they are not assigned the

usual interpretation of ‘bare’ verbs with subjects, i.e. Perfective (see Chapter 2). Condition (i) is what separates **pa**-embedding from control constructions, contrasting, e.g., (1) with **n misti tira l bariga** ‘I want to abort her’, where the wanter and the abortionist are necessarily one and the same person.<sup>3</sup>

Condition (ii) seems to be infringed in (4). Consider, however, that the contribution of **ba ta** is modal rather than aspectual, as shown by the gloss ‘from now on’ (and see the analysis of **ba ta** in Chapter 3). The same sentence without **ba ta** would still be grammatical and would receive the same interpretation, viz. that paying the announcements before broadcasting them is a state of affair that proceeds from and is temporally subsequent to the direction’s decision. Such a ‘relative future’ meaning is a constant for all predicates embedded with **pa**.

Does it involve that we should modify FCR (40) of Chapter 2 according to which verbs not dominated by an aspectual auxiliary are given a Perfective interpretation? Not at all. Indeed, I was cautious to state it in such a way that ‘bare’ verbs receive the unmarked or, to put it otherwise, default aspectual reading. Now, default reading, i.e. that reading which is produced in the absence of all explicit indication, will vary according to the context. In autonomous finite sentences, Perfective — viz. the understanding that the state of affair denoted by the predicate is a fact of the world, accomplished or extent depending on the predicate — seems indeed the most natural value. In dependent sentences, on the other hand, dependance from the matrix predicate will naturally be the unmarked option. Actually, it will be the only option with factive verbs, given that those necessarily imply causal or, at least, chronological consecution between their denotation and that of the subordinate predicate. Hence the fact that sentences headed by **pa** always refer to events or states whose time of (possible) reality is posterior to the time of the mental state or action denoted by the factive verb commanding **pa**.

Of course, this argument extends to control constructions where non finite predicates are also given a relative future interpretation, as repeatedly observed. What is then the difference between finite and non finite predicates? As already suggested I would claim it lies not in the presence vs. absence of Tense or Aspect as went a hasty conclusion based on mainly English data. Rather, it lies in the presence vs. absence of an autonomous subject. Controlled infinitives as in **n misti tira l bariga** or its English or Portuguese translations (*quero aborta-la*) head non finite predicates inasmuch as the predication they make constitutes a subset of the matrix predication as far as the subject is concerned. They are not propositions, in other terms, but chunks of propositions. A consequence of this line of reasoning is that Portuguese inflected infinitives are not actually non finite. As a matter of fact, Kriyol **pa** constructions can often be matched with equivalent Portuguese expressions using inflected infinitives. For instance, (3) would go *não me permitiui para*

*eu falar correctamente*. There is even the definite possibility that *pa* constructions have their historical origin in such Portuguese constructions where an inflected infinitive depends from *para*. On the other hand, unmarked aspect in subordinated sentences seems to be a universal feature among substrate and adstrate languages. To sum up, I would like to emphasize that unmarked or default aspect is not another (say zero) aspect. It is no aspect at all, so that the predicate is interpreted according to other principles than grammatical marking. What these principles are, I will not try to unravel here. Let me just suggest that meaning postulates in the spirit of, for instance, Dik (1978) might be a good way to formalize the process, whatever its ultimate cognitive reality.<sup>4</sup> One such meaning postulate (MP) might sound like this:<sup>5</sup>

- (5) MP: If no explicit grammatical means indicate(s) the aspect value of a VP, assess this value as (a) whatever Perfective means, if the VP heads an autonomous sentence; or (b) dependent from the value of some higher VP if the bare VP heads a subordinate sentence or is a complement VP.

Clause (b) caters for both finite embedded sentences (under *pa* in Kriyol) and non finite (infinitive) controlled VPs. ‘Subordinate’ was preferred to ‘embedded’ because embedded sentences may preserve their aspectual autonomy, as we shall see in the following section, hence not be subordinate in what I would like to be the real sense of the word. Whereas condition (a) is language-specific, depending as it does from the possibility of having unmarked verbs in autonomous sentences in the language (yes in Kriyol, Mandinka, and several Atlantic languages — *inter alia* no doubt; no in Portuguese, English, etc.), condition (b) is probably universal.<sup>6</sup> Note that it must itself be made dependent from another MP saying:

- (6) MP: If the aspect value of a VP is assessed as dependent from the aspect value of some other VP, then understand the dependent VP as denoting a state of affair that is consecutive (in a causal and/or chronological sense) to the state of affair denoted by the dominating VP.

### 5.2.2. Complement sentences under declarative and epistemic verbs: *kuma*

Consider the following examples:

- (7) Ora ku i bin bu ta fala l kuma n tisi l si baka. (I)  
time that he come you A tell him KUMA I bring him his cow  
‘When he comes, you’ll tell him I brought him his cow.’

- (8) No na aviza publiku kuma i na ciga awos un delegason di  
 we A inform audience KUMA it A arrive today a delegation from  
 Senegal. (RB)  
 Senegal  
 'We are informing the audience that a delegation from Senegal will  
 arrive today.'
- (9) Janki Wali nega kuma el ku si pubis e ka na para bibi. (K)  
 Janki Wali refuse KUMA he and his peoples they NEG A stop drink  
 'Janki Wali declared that he and his peoples would never stop  
 drinking.'
- (10) I ka sin ku n pensa ba kuma kusa na bin sedu. (FJGK)  
 it NEG so that I think PAST KUMA thing A and-then be  
 'It is not so that I had thought things would turn out to be.'
- (11) Janki Wali sibi ba ja kuma kil tanpu janfadu. (K)  
 Janki Wali know PAST already KUMA that spring be-bewitched  
 'Janki Wali already knew that that spring was bewitched.'
- (12) Parsi n kuma no ka ten ja mafé. (HGCS)  
 seem me KUMA we NEG have already mafe  
 'It seems to me we haven't any mafe any more.'

These examples are designed to illustrate two things about *kuma*-constructions. One is the range of verbs that call for them, that is all verbs denoting acts of speech or states of awareness. Among the former, note that *fala* 'say, tell' is ambiguous between two meanings: a declarative verb in the sense of 'tell X that Y VP', it is also a factive verb meaning 'tell X to VP'. In Kriyol as in English, the ambiguity is resolved through the kind of construction that is selected. The other thing is that, contrary to predicates depending from factive verbs, the aspect value of predicates under declarative and epistemic verbs is entirely autonomous. In (7), for instance, the time when it is true that 'I brought him his cow' is clearly anterior to the time of the speech act (S in Reichenbachian symbolism) through which I will ('when he comes') inform him of the fact. It could equally well be posterior to it, as in (8) where the reported event (the delegation's arrival) follows the report; or be unconnected to it as in (9) or (11) where the refusal to stop drinking (alcoholic beverages) or the spell cast on the spring both antecede and endure beyond the uttered 'no' or the realization.<sup>7</sup> The autonomy is of course a consequence of the semantic character of declarative and epistemic verbs insofar as the ontology of the thing said or known does not depend from the saying or the knowing. Hence, incidentally, the opacity effect exercised by such verbs: **no ka ten ja mafe** 'we haven't any mafe any more' in (12) does have a truth value; it is only that the truth value must (and in principle can) be checked outside the context of **parsi n** 'it seems to me'. Predicates subordinated to factive verbs, in contrast, have no truth value at all.

We could leave it at that, classifying **kuma** as the other realization of the category Complementizer in Kriyol. That things might actually be a little more complicated is shown by the following examples:

- (13) Kulegas kuma pa n bin rezerva elis vinti litru di kaju.  
 colleagues KUMA PA I come mark-down them 20 litre of cashew  
 ‘The colleagues told me to come and mark down 20 litres of cashew  
 wine for them.’ (HGCS)
- (14) N fala u ba kuma pa no disa.  
 I tell you PAST KUMA PA we leave  
 ‘I had told you we should give up.’ (FJGK)
- (15) Janki Wali coma Nfamera pa kila fala tudu gererus kuma pa  
 Janki Wali call Nfamera for that-one tell all warriors KUMA PA  
 e purpara pa ba vinga se kunpanyerus. (MK)  
 they prepare for go avenge their comrades  
 ‘Janki Wali called Nfamera so that the latter would tell all the  
 warriors to make themselves ready to go and avenge their  
 comrades.’

In (13), we see **kuma** show up where we would expect a verb such as **fala**, here with its factive meaning. Before proceeding any further, this very fact should incite us to try and discover a bit more about this item. Contrary to **pa**, **kuma** has no obvious etymology in Portuguese. The best one I could come up with is *coma*, an archaic variant of *como* ‘as, how’, still in use in the 16th and 17th centuries. The meaning fits as it is not an unheard-of occurrence for ‘as’ or ‘how’ to be used as a complementizer after verbs of saying and knowing.<sup>8</sup> And the sound as well, considering that *coma* so used would be unstressed, so that /o/ would normally be raised to /u/, a process already under way in 17th century Portuguese, and which was to come to completion in European Portuguese at the end of the 18th century (see Neto 1988:482ff.; Teyssier 1980:77). Actually, this reconstruction finds an independent support in Brazilian dialects of the Nordeste where an item spelt *cuma* is used very much like Kriyol **kuma** is.

What about constructions such as (13), however, which no dialect of Portuguese accepts, as far as I am aware? They lead us to consider another possible origin of **kuma** (not exclusive, of course, of the first one), viz. Mandinka *kuma* ‘to speak’, thereby meeting the track of all creole and non creole languages that use some variant of ‘say’ as a complementizer after verbs meaning ‘say’ or ‘think’. Mandinka itself does not use *kuma* in this function, but it does use *kó* ‘say’ in, e.g. *a y’aa lóng kó... /he AUX it know say/ ‘he knows that...’* (Rowlands 1959:92). The parallelism between Kriyol **kuma** and Mandinka *kó* is even more striking if one considers that (a) both items can only appear in the bare form; (b) both are intransitive. Clause (a) implies that the only possible aspectual value of **kuma** and *kó* is Perfective as in (13). For all other values, they must be replaced with **fala** and

*fo* respectively.<sup>9</sup> For instance, ‘the colleagues will say...’ cannot be rendered in Kriyol as \**kolegas na kuma...*, but it must be *kolegas na fala...*, with *kuma* then appearing in complementizer position as in (14), if need be. As for clause (b), it means that *kuma* (similarly *kó*) never select an NP complement, but must be followed either by a direct quote or by indirect speech, as in the following two examples:

- (16) Tartaruga kuma kil ku na bin sinta bu pera. (PB)  
 tortoise KUMA that that A come sit-down you wait  
 ‘The tortoise said, ‘Sit down and wait for what will come.’
- (17) Mursegu kuma i na misa Dews. (PB)  
 bat KUMA he A piss God  
 ‘The bat says he will piss on God.’

No mention of an addressee is possible in these sentences — which may be why such constructions are especially frequent in ritualized declarations such as (16) and (17), both proverbs; in tales or narratives, on the other hand, one regularly finds such expressions as *i fala l...* ‘he told him...’ (\**i kuma l*). Neither are things like \**tartaruga kuma un kusa difisil* admissible (OK *tartaruga fala un kusa difisil* ‘the tortoise said something difficult’).<sup>10</sup> A further limitation on verb-like *kuma* is that it cannot be negated, and one could not say, e.g., \**mursegu ka kuma i...* Again, *fala* should be used instead. Given the verbal character of the Kriyol negation (see Chapter 2), this limitation obviously proceeds from *kuma*’s obligatory ‘bareness’.

Finally, note that in constructions such as (17) verb-like *kuma* may never be followed by complementizer-like *kuma* (\**mursegu kuma kuma i...*). It is generally true that *kuma* in apparent C- position is optional, so that (7), e.g., could equally well be rendered as ... *bu ta fala l n tisi l si baka*. (*Kuma*-‘deletion’ does not seem to be as frequent as *that*-deletion in similar contexts in English, though. It never occurs when *kuma* is factively interpreted as in (14)) When *kuma* is the declarative verb being used, optionality thus turns into prohibition.

To sum up this syntactic overview, the following five configurations present themselves: (a) optional complementizer-like *kuma* dominated by a declarative or epistemic verb (other than itself) and dominating a clause of reported speech or thought (see (7)); (b) categorical complementizer-like *kuma* dominating a clause with *pa* in C-position (see (14)); (c) verb-like declarative *kuma* directly dominating a clause of reported speech (see (17)); (d) verb-like factive *kuma* dominating a clause with *pa* in C-position (see (13)); (e) verb-like declarative *kuma* introducing a quote (see (16)).

The parallelism between ‘both’ **kumas**, i.e. between (a-b) on the one hand and (c-d) on the other hand, is quite striking. The natural way to resolve it, I think, is by assuming that there is really only one **kuma**, and that it is a verb in all cases. Having a verbal element acting as a complementizer does not pose problems to a theory like GPSG or HPSG. It has even been proposed (see Borsley 1989) that complementizers should receive a [+V] feature as a way of capturing the notion put forward in GB theory that the clause is a maximal projection CP of C(omp) (see, e.g., Chomsky 1986), whereas it is considered a maximal projection of V in Gazdar et al. (1985). I would therefore propose the following tree for configuration (a), i.e. (7):

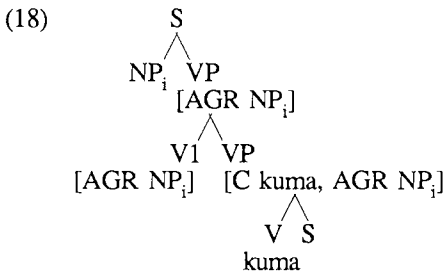

In (18), a representation of, e.g., **i fala l kuma...** ‘s/he told him/her that...’, the subject NP of the higher clause is the controller of all VPs down to the lower clause through the FOOT feature AGR (see Gazdar et al. 1985:121). (Recall that such features as AGR or SLASH are abbreviations for parallel representations matching a syntactic with a semantic structure.)<sup>11</sup>

Putting aside a number of problems that will be dealt with later on, the first question to be asked, naturally, is about the tense-aspect value of **kuma** in this position and its status as to the finite vs. non finite contrast. Since **kuma**’s subject is never autonomous, we must take it as being non finite by the above definition. On the other hand, semantics tells us that the time at which the mental act denoted by **kuma** is verified must be coterminous with that at which the mental act denoted by the higher verb is verified.<sup>12</sup> There is here a crucial difference with the tense-aspect denotation of infinitives in control constructions (see above).

I propose that this conjunction — same subject, same tense-aspect value as some verb serving as a reference — should be subsumed under the category ‘gerundive’. Informally, this means that **i fala l kuma...** translates literally as ‘s/he told him/her, saying...’. The gerundive ‘saying’ of the quasi-English sentence has indeed all the characters of Kriyol **kuma**. Formally, it means that one tense-aspect operator may have two verbs in its scope when those verbs are both predicated of the same argument. Since both chainings are mutually independent, as shown by controlled infinitives, it is better, I think, to represent them in different planes, as in the following semantic representation:

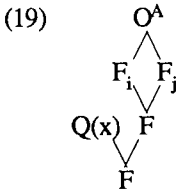

$F_i$  and  $F_j$  correspond to the two verbs, **fala** (or some equivalent) and **kuma**. Both stand under the same operator in what could be called the ‘Time orientation’ plane or module. They are unified as one formula (F) predicated of one argument (Q(x)) in the predication plane or module.

Before we proceed to other configurations, a side issue has to be raised briefly, viz. that of serial verbs. Couldn’t (18) and its associated semantic structure (19) actually be viewed as representing a serial verb construction? The answer I would like to give is that yes, they might — provided the serial verb construction in question has all the characters of what I analysed as a main verb plus gerundive construction. As a matter of fact, it would: serial verbs, in order to qualify as such, must share the same subject and be temporally coterminous.<sup>13</sup> From this point of view, a serial verb analysis would not constitute a real alternative. Moreover, serial verbs typically involve two (or more) denotationally distinct verbs in order to describe different aspects of the one complex event denoted by the whole series (see example in the last footnote). Here, in contrast, there is no real semantic difference between the first verb and **kuma**. In fact, declarative **kuma** is almost totally redundant with respect to the first verb, which probably explains why it can easily not be generated at all. Such a fact does not plead strongly in favour of the serial verb analysis. Consider further that no other instance of the construction can be found in Kriyol (see below), and the alternative account, if it is one in the first place, simply vanishes as a reasonable possibility.<sup>14</sup>

Configuration (b), i.e. (14), follows immediately from the assumption that **kuma** is ambiguous between a declarative and a factive interpretation, just like English ‘tell’ is. In the latter meaning, it will naturally select a complement clause headed by **pa**, hence the following syntactic structure for (14), with everything above the second VP as in (18):

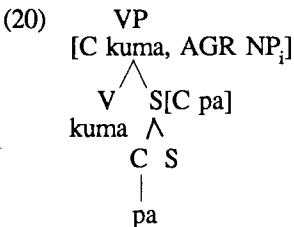



Tree (20) represents the case where **kuma** is factively understood. (Again, see below for details of construction.) Should it be declaratively interpreted, we would be back to (18), which is entirely identical with (20) except for the fact that the C position is then empty or not generated. (It could only be filled with **kuma**, but recall that successions of **kuma** are unallowed. I will return to this.)

Since it is a verb, nothing can prevent **kuma** from being the head of a proposition with an explicit subject, with due provision for its defectivity, viz. that it should appear unmodified by any auxiliary, including the negation.<sup>15</sup> This accounts directly for configurations (c) — i.e. (17) — and (d) — i.e. (13). Finally, configuration (e) — i.e. (16) — simply reflects the fact that every declarative or epistemic verb can introduce a verbatim report of the speech, thought, belief, etc. currently at the centre of attention.

Given the centrality of **kuma**'s verbal character in the whole preceding argument, readers might ask why it was felt necessary to go into the complication of identifying **kuma** as a complementizer in (18) and (20) all the same. Why, to put it differently, couldn't we be content with a straightforward succession, more or less like this:

(21) [<sub>S</sub> i fala][<sub>S</sub> e kuma][<sub>S</sub>...]

We can't for at least two reasons. Firstly, (21) offers no grammatical way to warrant that the null subject of **kuma** will always be coreferential with that of the preceding clause. Since what we have is actually a succession of autonomous sentences, the author of the speech act denoted by **fala** could well be a different person from the author of the speech act denoted by **kuma**. Discourse principles, the only ones that could be invoked then, would not be apt to ensure that both authors are obligatorily the same, as they actually are. Local semantic and syntactic principles like the CAP or its autolexical reinterpretation and none others are in measure of fixing this unvarying identity.

Secondly, there are definite tests that show that (21) cannot be right and that **kuma** must indeed figure in an embedded structure. Take 'extraction' constructions such as **es i omi ku n fala kuma i fasi kila** /this it man that I say KUMA he do that/ 'this is the man that I thought did that', or **kal omi ku bu pensa kuma Jon kungsi I** /which man that you think KUMA John know him/ 'which man do you think that John knows?' Kriyol employs the resumptive strategy consistently (see below), so that the pronouns in the clauses following **kuma** behave exactly like null elements do in English. They must be coreferential to the 'extracted' NP. Again, if (21) was the correct structure, one would expect them to be free in reference since no syntactic dependency would unite the successive clauses.

Granted this, one might still consider (18) and (20) to be unnecessarily complex, preferring an apparently simpler structure such as the following:

(22) [<sub>S</sub> i [<sub>VP</sub> fala [<sub>S</sub>[<sub>C</sub> kuma [<sub>S</sub>...]]]]]

The problem with (22) is symmetrical to that posed by (21). There, we made too much of the verbal character of **kuma**; here of its complementizer (C) feature. That is, we miss the generalization that is strongly suggested by the evidence, and we are forced to assume two **kuma**, one for configuration (a) alone, the other for configurations (b-e). It is precisely this generalization that (18) and (20) aim to capture through the dual characterization of **kuma** as a verb and as a complementizer. I will now try and be a little more precise as to how the syntactic machinery is implemented.

Let us assume, following Gazdar et al. (1985:112ff), that Kriyol sentences may receive a feature C(OMP) whose values are either **kuma** (C kuma) or **pa** (C pa).<sup>16</sup> FCR 15 ([COMP] ⇒ [+SUBJ]) is thus valid in Kriyol as, presumably, in all languages. On the other hand, since the choice of the proper value for C depends on the semantic category of the matrix verb, the value, it seems, will have to be introduced through a specific ID rule. For **pa**, this is straightforward:<sup>17</sup>

(23) VP → Hn, W, S[C pa] (disidi, fala<sup>f</sup>, kuma<sup>f</sup>, misti, permiti,...)

In turn, this rule functions with the non lexical ID rule (24) — see Gazdar et al's (16), p. 113:

(24) S[C pa] → {[SUBCAT pa]}, H[C NIL]

That is to say, a sentence bearing the feature [C pa] immediately dominates the lexeme **pa** and a head, here another occurrence of S, whose value for C is NIL, as there is only one complementizer per clause. Note that the lexical definition of **pa** with respect to the [±N, ±V] categorization is not implied by this rule. All it specifies is that **pa** is a subcategorizing lexeme whose unique function is to spell out the C feature of the sentence expanded by (24). Apart from that, it seems reasonable to define it as a particle or a preposition — if this deserves the name of a definition — but nothing in principle opposes its being anything else.<sup>18</sup>

That things cannot work exactly in this way with **kuma** is shown by examples such as (14) where two complementizers would seem to follow one another. Moreover, the verbal character of **kuma**, although not precluded by (24) as just explained, is not properly taken into account in the way it is formulated. I will therefore propose the two following lexical ID rules for declarative and epistemic verbs selecting **kuma**:<sup>19</sup>

(25) VP → Hn, W, S[-C] (aviza, fala<sup>d</sup>, kuma<sup>d</sup>, nega, parsi, pensa, sibi,...)

(26) VP → Hn, W, VP[C kuma, AGR NP\*] (aviza, fala<sup>d</sup>, nega, parsi, pensa, sibi,...)

Rule (25) says that the verbs listed subcategorize for a clause with no C value. It thus accounts for constructions where **kuma** is 'deleted', i.e. in fact not present, including (17). Rule (26), in contrast, accounts for constructions where **kuma** is used. It applies to exactly the same verbs, except **kuma<sup>d</sup>**, which does not figure in the list. It says that those verbs also subcategorize for a VP whose head bears a C feature spelt out as **kuma** and agrees with a higher NP. We now need a rule to expand VP[C kuma, AGR NP\*]. A simple reiteration of (25) will do:

(27) VP[C kuma, AGR NP\*] → H, S[-C] (kuma<sup>d</sup>)

This is a rule restricted to one item, and, as such, it is subsumed under the more general (25). Note that the unspecified environment W is excluded from (27). Also, the fact that (26) licenses trees where a VP follows another VP (see (18)) aptly captures, I think, the element of parataxis present in these constructions in spite of their clearly embedded character — see the English gloss, 'he said, saying (that)...'

Notice that rule (27) introduces the possibility of an infinite recursion. Indeed, if **kuma<sup>d</sup>** were permitted to select a sentence bearing [C kuma] as a feature, i.e. if it was not pointedly excluded from the range of rule (26), then that sentence would itself expand as [*e* kuma S[C kuma]], and so on, and infinite sequences of **kuma** would be generated (i **fala kuma kuma kuma...**). I will return below on the semantic significance of this limitation. Given that, the rest is simple: depending on the meaning of **kuma**, rule (23) or rule (25) will apply, and tree (18) or tree (20) will be fully licenced.

To an extent, then, the lowest S, that expressing what is said or thought, can be said to be embedded under **kuma** rather than under the highest VP. Hence the importance of assigning a positively defined C feature to the sentence headed by **kuma** in order to ensure the continuity of the syntactic link. Now, it is a fact that the continuity is also ensured by the remote dependency in terms of tense-aspect and subject reference as schematized in (19). The [C kuma] feature thus appears somewhat redundant, and one feels tempted to examine whether it could not be dispensed with, especially since one may feel uncomfortable with a complementizer feature being assigned to a subjectless VP.

This can be done, I think, using the full expressive power of parallel representations — which makes the move desirable in addition to being feasible. A small theoretical innovation is necessary, viz. that elements in the right-hand side of a lexical ID rule should be allowed to mention specific intermodular associations. For instance, (26) would be rewritten as:

(26') VP → Hn, W, S=(19) (aviza, fala<sup>d</sup>, nega, parsi, pensa, sibi,...)

The import of (26') is that declarative and epistemic verbs (minus **kuma**<sup>d</sup>) can subcategorize for a sentence whose representation involves an association of its syntactic structure with the semantic structure shown in (19). What we must provide for, then, is that only **kuma** will head this sentence. That it must be headed by a declarative verb rather than by any verb follows from (19) which, modulo some necessary developments I will not attempt here, ensures that the head of S=(19) constitutes a semantic replica of the head introduced by (26'). The head of S=(19) must therefore be a verb that can be a semantic replica of every declarative or epistemic verb in the list appended to (26'). In other words, we need a lexeme whose meaning is sufficiently abstract that it denotes all speech acts and all types of mental activities. This will be the meaning of **kuma**. Of course, there is no word in English to translate this meaning (except 'that'). Perhaps 'express' would be the verb coming closest to the required level of abstraction.

This solution has several advantages. For one, it is basically lexical since everything follows from the lexical definition of **kuma** (see below) as it functions within interrelated modules. A rather natural explanation is also given for **kuma**'s exclusion from the list appended to rule (26'). Not only would its inclusion lead to potential infinite recursion, but it would make no sense at all. Given its abstractness, **kuma** is a representative of semantically 'fuller' verbs; there is absolutely no point in representing it one more time. When **kuma** appears, it is time for something with content to be finally uttered. Repeating **kuma** would be equivalent to stammering over a complementizer ('He said that-that-that...'), never coming to the point.

Note that this holds good when **kuma** is introduced by rule (25) as in (17). A traditional assumption is that **fala** is then 'understood' (*sob-entendido*). We can agree on that as long as actual deletion is not what is meant. More accurately, I think, we should say that, whenever it is used autonomously, **kuma** is interpreted by default, as the most general, less particularized member of its class, viz. as 'say'. (Why should 'say' be chosen as the default meaning rather than 'think', i.e. why is understanding automatically tilted towards the declarative sub-class, is something I won't try to explicate, although it does not strike me as particularly surprising.)

The semantic abstractness of **kuma** makes it akin to fully grammaticalized items such as complementizers. That is not to be denied. Yet, given the logic of a parallel representation model, we are not forced to have recourse to such ad hoc categories as 'complementizer-verb' or, worse still, to unconnected items in the lexicon. This is another advantage of the present account.

A further one is that it reduces the number of ‘pure’ complementizers that have to be posited (i.e. abstracting from such items as ‘if’, ‘when’, etc.). Putting aside an item of dubious status that will be examined in a moment, there is actually only one value for C in Kriyol, and that is **pa**, following factive verbs. As a result, we obtain an interesting generalization, viz. that declarative and epistemic verbs subcategorize for a complementizer-less sentence, unless they are followed by a VP. The sentence is the report, whereas the VP can only be headed by **kuma**, which then selects a reporting sentence, again without a complementizer. This makes Kriyol remarkably similar to other creole languages of different lexical bases. Compare, e.g., Haitian *li di pou ou vini demen* /he say POU you come tomorrow/ ‘he told you to come tomorrow’ vs. *li di ou ap vini demen* /he say you ASP come tomorrow/ ‘he said (that) you’ll come tomorrow’. Haitian has no lexeme comparable with **kuma**, but that would be the only difference between it and Kriyol in this domain.<sup>20</sup> These facts will be interpreted according to one’s favourite theory of creolization, but they are worthy of notice in themselves.

Now it is fair to mention that the grammar just described, to the extent that it is valid, is probably fully so for only the most conservative variety of the language. A particularly illustrative example of this variety is the following sentence from a tale:

- (28) I ta manda kil mininu ku bruta di puti kuma pa i kata yagu.(MM)  
 he A send that child with brute of pot KUMA PA he fetch water  
 ‘He always sends that child with a huge pot, having told him to go  
 fetch water.’

Here, the declarative verb which **kuma** resumes has to be inferred from the knowledge that sending somebody to do something is usually done by way of speech. This confirms that **kuma** is not subcategorized for in a strictly syntactic sense. Hence the adequacy of the semantic detour as in (26’), with the consequence that the list appended to the rule ought to be opened to all verbs denoting events whose effectuation involves speech in a crucial way (including ‘send’, but excluding ‘kill’ for example).<sup>21</sup>

In more ‘advanced’ or ‘decreolized’ varieties, in contrast, **kuma**’s status is not so clear. Take, for instance, the following two sentences recorded during the news programme on the radio:

- (29) I ta pensadu na utru ladu kuma reunyon ma garandi di OUA  
 it A be-thought on other side KUMA meeting more big of AUO  
 dibi na bin fasidu i ka na tarda. (RB)  
 must A be-later be-made it NEG A last  
 ‘It is believed on the other hand that a bigger AUO meeting will take  
 place in a little time.’

- (30) Arap Moy fasi un propostu di kuma pa i fasidu ba un mini-  
 Arap Moy make a proposal of KUMA PA it be-made PAST a mini-  
 simeyra. (RB)  
 summit  
 'Arap Moy made a proposal to the effect that a mini-summit should  
 be organized.'

The impersonal passive of the first sentence poses a problem to our analysis. Indeed, pleonastic *i* cannot be the controller of *kuma*. But nothing else can be the controller, since the semantic subject of *pensa*, i.e. the entity fulfilling the role of the believer as well as of the expressor of the belief, is not mentioned — and may well not exist at all. Given that nothing may be done to the syntax, for theoretical as well as empirical reasons (see below), it is still possible, no doubt, to manipulate the semantics in such a way that *kuma*'s subject will be linked to a virtual subject of *pensa*. Yet, it is probably more reasonable to consider that, in such a highly uncolloquial register, *kuma* functions as a simple complementizer calqued after Portuguese *que*. Similarly in (30), one is tempted to analyse *kuma pa* as a complex complementizer combining the report of a speech act ('proposal') and the effectuation of a projected action. (Note that English 'propose' is slightly ambiguous in this respect — see 'she proposed that we should go' vs. 'she proposed to go'.) It is interesting, however, that the syntax and semantics of 'deep' *kuma* still lurk in those constructions, and that, to the best of my knowledge, Portuguese *que* is never imported as such, but only as an interference.

A final characteristic of *kuma*, whatever its status, is that it does not have to be adjacent to the clause it selects but may be separated from it by an intervening clause. Witness the following example:

- (31) Gosi n pensa kuma, suma ku bu mame sibi, i ka ten  
 now I think KUMA as that your mother know it NEG have  
 purblema. (HGTM)  
 problem  
 'Now I think that, since your mother knows, there isn't any problem.'

This would be impossible with *pa*. Kriyol, it seems, does not tolerate such constructions as P. *quero que, logo que for possível, venhas* 'I want you to come as soon as possible', which has to be rendered as *n misti pa bu bin ora ku bu pudi* 'I want you to come when you can'. This is connected, of course, to the lesser degree of sententiality evidenced by clausal complements of factive verbs (see Noonan 1985). Even when it is possible, separation is more marked stylistically after a factive verb, as in the Portuguese example, than after a declarative or epistemic verb, as in (31).

To conclude on this matter, it is worthwhile, I feel, to reflect on the nature of the segment of discourse introduced by **kuma** and declarative/epistemic verbs in general. A feature of Kriyol not mentioned so far is the absence of anything like a tense sequence. As a consequence, potential ambiguities arise in utterances such as **i fala (kuma) n na bin**, which may mean either ‘he said I would come’ or ‘he said, “I will come”’. I wrote ‘potential’ because in actual speech the second interpretation will normally involve a longer pause between **fala** or **kuma** and the rest of the utterance than does the first interpretation. It appears, however, that, even though English may do without an overt complementizer in such cases, a visible syntactic linking is maintained between the matrix clause and the complement clause thanks to the sequence of tenses ‘switching’ *will* to *would* (see Enç 1987 on this matter). No such linking is available in Kriyol, where tense-aspect in the embedded clause is determined with respect to ‘objective’ time only (insofar as my coming is future relative to his saying). There is therefore no non-phonological distinction between direct and indirect speech other than the denotation of referring expressions — in the sense that ‘I’ means the actual speaker in the indirect speech interpretation, the reported speaker otherwise.

In view of this, it seems to me that sentences embedded under declarative or epistemic verbs in Kriyol, including **kuma**, are adequately characterized with the notion ‘free indirect discourse’ (see Banfield 1978; Kuroda 1973). That is to say, they have all the characters of directly reported speech between quotes, except for the systematic switching of pronominal reference. Rules (25) and (26’), according to which declarative and epistemic verbs select complementizer-less sentences, are thereby grounded in discourse reality. Conversely, free indirect discourse, a recent invention as a literary device, may thus be seen to be actually grounded in linguistic competence.

The following lexical matrix sums up the essential of what has been argued for in this section:

- (32) **kuma**  
 category [MAJ V, C+, VFORM ±FIN, SUBCAT <S±C>, SPEC  
 <>, SUBJ <NP / AGR NP\*]  
 morphology: nil  
 syntax: V0[Rules 25, 26’, 27]  
 semantics: NP1 **kuma** S  
     NP1 = author of speech act or mental activity (possibly  
           unexpressed and linked to overt NP1 in higher sen  
           tence through [29])

- kuma** = express' (abstraction of declarative and epistemic verbs [**kuma**<sup>d</sup>] or of factive 'say' [**kuma**<sup>f</sup>]); bare form only, interpreted as positive perfective if NP1 expressed, as gerundive otherwise (temporally linked to VO denoting event involving speech or mental activity in higher sentence through [29])
- S** = content of speech act or mental activity expressed as direct or free indirect discourse if **kuma**<sup>d</sup>; as embedded clause under **pa** if **kuma**<sup>f</sup>

In the HPSG format categorization of **kuma**, the C+ feature has been maintained, although it must be understood not as a substantial attribute, but as an abbreviation for the syntax-semantics association delineated above. Otherwise, **kuma** is hereby described as a finite verb subcategorizing for a clause with or without a C feature, and either taking a full subject or sharing a subject with a higher verb denoting some event having to do with speech (whereas **pa** takes no subject at all). A meaning postulate must be added to (32):

- (33) If **kuma** is not linked to a higher verb, then interpret it by default as meaning 'say', declaratively or factively understood.

Together, (32) and (33) make explicit (almost) all that has to be known in order to use ('deep') **kuma** grammatically.

#### 5.2.2.1. Complement sentences of declarative and epistemic verbs: a follow-up (*nos*)

In certain contexts where **kuma** could appear, one sees in its place a lexeme **nos** whose meaning is shown by the following examples:

- (34) Bu ta pensa nos algin ka sta la. (MJGK)  
 you A think NOS somebody NEG be there  
 'You'd think nobody was there.'
- (35) Ka e pensa nos e pudi maja n. (MSNP)  
 NEG they think NOS they can smash me  
 'Let them not think they can smash me.'
- (36) I ka bon bay byas sin sibi nos kaminyu sta linpu. (MC)  
 it NEG good go trip without know NOS path be clean  
 'It is not good to go on a trip without knowing whether the omens are favourable.'

The last example would suggest that **nos** is simply the equivalent of English 'whether, if' or of Portuguese *se*, as an introducer of indirect questions.<sup>22</sup> Besides, it could easily be replaced by **si** (but also by **kuma**!).

However, examples (34) and (35) show that this cannot be the whole story. In both of them, **kuma** could take the place of **nos** without altering the grammaticality of the sentence — but **si** could not. What **nos** contributes is a distinct nuance of



counterfactuality. You would think nobody was there, when actually the place was full of people; they mustn't think they can smash me when obviously they can't; and so forth. This nuance would be lost with **kuma** instead of **nos**; (34), for instance, would become neutral as to whether somebody is actually there or not. Only in sentences like (36), probably because a state of ignorance is asserted (**sin sibi** 'without knowing'), are **nos**, **kuma**, and **si** freely interchangeable.

Given the functional equivalence of **nos** and **kuma**, modulo the counterfactuality feature, one is tempted to analyse them both in the same way. Unfortunately, there is no really reliable sign that **nos** can be considered a verb. The example in footnote 22 is suggestive in that it looks structurally rather similar to (28), with **nos** a gerundive verb meaning something like 'see if'. Yet, as we saw, an adverb analysis is available, which may be considered simpler. Otherwise, the only position where **nos** regularly appears is following a VP and dominating a finite clause embedded under the VP. Moreover, the lexical identity of VOs selecting **nos** seems to be quite limited: it is either **pensa** 'think' (or a synonym such as **kuda** 'think, believe') or **sibi** 'know', especially in the negative.

As a consequence, and given the scantiness of the evidence that might justify analysing **nos** as **kuma**, i.e. as a gerundive verb sharing a subject with a higher verb through the assignment of a FOOT feature AGR (or (29)), there seems to be no option but to assign another possible value to C besides **pa**, viz. [C nos], and have it introduced by the following, quite approximate, lexical ID rule:

(37) VP → Hn, W, S[C nos] (*pensa, kuda, ka sibi...*)

The verb list appended to (37) constitutes a subset of the verb list appended to (26'), which accounts for the overlapping of **nos** and **kuma**.<sup>23</sup> As for the lexical matrix of **nos**, it might look as follows:

38) **nos**  
 morphology: nil  
 syntax: C[Rule (37)]  
 semantics: VP nos S  
     VP = instance of thinking, believing or ignoring  
     S = proposition counterfactually thought or asserted as ignored

### 5.2.3. *Adjunct complement sentences*

Under this heading come sentences expressing circumstances afferring to some matrix (or 'principal') sentence. The traditional labels of temporal, causal, place, purpose, concessive, and manner clauses will serve us fine. Recall that conditional sentences have already been studied in Chapter 3 in connexion with Aspect.

To begin with, here are some examples of temporal clauses:

- (39) Ora ku i na bin bu ta fala l kuma n tisi l si baka. (I)  
 time that he A come you A say him KUMA I bring him his cow  
 'When he comes, you'll tell him I brought him his cow.'
- (40) Si i ciga no na janta. (I)  
 if/when he arrive we A lunch  
 'We'll have lunch when he comes.'
- (41) Kontra sol noti Midana bay kumite. (I)  
 meet/against sun become-dark Midana go committee  
 'When the sun set, Midana went to the committee.'
- (42) Kriyol i lingwa ku n mama dedi oca ku n pikininu. (I)  
 Kriyol it language that I suckle since find that I little  
 'Kriyol is the language I've been suckling since the time when I was  
 a little boy.'

Simple 'when' has four correspondents in Kriyol: **ora ku** or **si** if the events denoted by the temporal and the matrix clause both lie in the future with respect to speech time; **kontra (ku)** or **oca (ku)** if they lie in the past. As a correlate of this basic distinction, **kontra/oca (ku)** imply simultaneity of both events, so they are often best translated as 'at the moment when', 'as soon as'. As far as syntactic structure is concerned, **ora ku** is transparent: **ora** means 'time' (P. *hora* 'hour' — compare Haitian *lè* 'when' from French *l'heure* 'the hour') — and it keeps this meaning in such sentences as

- (43) N sopra restu pa ora ku n riba. (HGTM)  
 I keep rest for time that I return  
 'I kept the rest for when I return.'

It is therefore quite possible to analyse **ora ku i na riba** in (39) as a topicalized NP containing a head, **ora**, and a relative clause.<sup>24</sup> Support for this analysis is given by the fact that such phrases almost always precede the sentence they are appended to, that is to say they occupy the normal position for topicalized NPs (see below). Also note **si**'s vacillation between the meanings 'if' and 'when' — the context of (40) made it clear that the man's arrival was not in doubt — a semantic characteristic of many surrounding languages (compare Mandinka *ni*, Wolof *su*, etc.).

The other two items are harder nuts to crack. **Kontra** may be related either to the preposition **kontra** 'against' (P. *contra*) or to the verb **kontra** 'meet, happen' (P. *encontrar*); **oca**, on the other hand, can only be related to **oca** 'find' (P. *achar*). Given such constructions as **si i kontra i sta la...** /if it happen he be there/ 'If he happens to be there' (compare Mandinka *n'ú y'aa tára a be wò le* /if you A it find he be there EMPH/ 'if it turns out he is there' — Rowlands 1959:78), however, I would fain dismiss 'against' as the immediate source of **kontra**'s temporal use.

A plausible assumption, it seems to me, is thus that **kontra** and **oca** (both ancient items judging by their phonetic forms) were first used *qua* verbs after substrate models. In that capacity, they may be considered gerundives, like **kuma**, with a null expletive subject (a possibility independently supported — see below) and a tense-aspect value linked to that of the matrix clause through a semantic schema similar to (29).<sup>25</sup> That would be the grammar of (41). Now, such constructions as (42) show that **oca** (and **kontra**), perhaps under the influence of **ora**, were reanalysed as nouns that can serve as heads for relative clauses and as complements for prepositions (**dedi** ‘since’, P. *desde*). Both grammars seem to coexist at the present time. (Note that, as **ku** is never ‘deleted’, (41) cannot be construed as an instance of the ‘newer’ grammar.)

Example (44) shows an interesting item, **tok(i)** ‘until’:

- (44) I rebental baril na kabesa tok i fura. (MSDB)  
 he burst him barrel on head until it pierce  
 ‘He hit him on the head with the barrel until there was a hole in it.’

It seems to represent the attrition of **te ora ku** ‘till the time that’ (witness the dialectal variant **tor(o)k(i)**), rather than a direct descendant from P. *até que*. The semantic converse of ‘until’, that is ‘since’, is expressed either by **dedi** as in (42) above (note that **oca** could be dispensed with and the expression reduced to **dedi ku**) or by a possibly more basilectal item, **disna**, as in the example below:

- (45) Disna ku si fiju muri i fika senpri ku aflison. (GM)  
 since that his son die he stay always with sorrow  
 ‘He has been ever sorrowful since his son died.’

As Rougé (1988) suggests, **disna** probably results from the contraction of some reflex of P. *desde* with **na** ‘in’.

More temporal clauses appear in the following two examples:

- (46) Dipus di i kaba laba... (MJMB)  
 after of he finish wash  
 ‘After he finished to wash...’  
 (47) Nyu jubi manera di rizulvi purblema antis di n leba nyu tribunal.  
 you look manner of solve problem before of I take you court  
 ‘Look for a way of solving the problem before I take you to court.’  
 (HGTM)

Given that all these items, **dedi**, **disna**, **dipus**, and **antis**,<sup>26</sup> are prepositions, I will assume they head PPs, so that the general syntactic structure corresponding to (42), (45), (46), and (47) is as below:

- (48) PP  
 / \  
 P S

As for (46) and (47), the simplest solution seems to be to consider **dipus di** and **antis di** as compound prepositions since **di** can never be left out (**antis/dipus di kwarta-fera** ‘before/after Wednesday’, not \***antis/dipus kwarta-fera**). This gives us the following lexical ID rule:

- (49) PP[PFORM *antis di, dipus di*] → P[PFORM *antis di, dipus di*], S[C-]

That is, a PP can immediately dominate a preposition whose form must be **antis di** or **dipus di**, and a complementizer-less clause.

**Dedi** and **disna** pose a different problem insofar as the clauses they introduce are headed by **ku**, which would make them relative clauses. Yet, there is no nominal head. Two solutions seem then available: (a) make an exception to the claim that **ku** occurs only in relative clauses; (b) supply an appropriate head. Out of consideration for the desirable consistency of the account, I will rather choose the latter tack. That is to say, I will assume the syntactic structure of (46) and (47) to be something like this:

- (50) 
$$\begin{array}{c} \text{PP} \\ \swarrow \quad \searrow \\ \text{P} \quad \text{NP} \\ \quad \swarrow \quad \searrow \\ \text{N} \diamond \text{S}[+R] \end{array}$$

The phonetically null NP head may be thought of as being actually **ora** ‘time’ — which could be fully realized, by the way, without any interpretive difference ensuing. All we need do, then, is provide **ora**’s lexical entry with the specification that it may be phonetically unrealized in the context of a specific rule, and write the following lexical ID rule:

- (51) PP[PFORM *dedi, disna*] → P[PFORM *dedi, disna*], N[NFORM *ora, +NULL*], S[+R]

That a noun meaning ‘time’ should be understood in a context specifically referring to time seems indeed natural enough.

Such an analysis, on the other hand, would not apply to **tok(i)** ‘until’, unless we assume a rather abstract underlying form for this item, namely that suggested by its etymology (**te ora ku** ‘until the time that’), optionally reduced to [torok], [tork], or [tok] through phonological processes.<sup>27</sup> A plausible analysis indeed, but one one may shy away from because of its somehow old-fashioned ‘SPE’ flavour. In that case, there is no way out but to assign **tok** as another value to C.

Finally, I give the following example to show that temporal relationships between propositions can equally well be expressed through paratactic means:

- (52) Kaw kaba na sukuru son, i riba pa minjer garandi. (I)  
 place finish A be-darkonly he return for woman old  
 ‘As soon as it was dark he went back to the old woman.’

The examination of temporal adjunct clauses thus uncovered two main syntactic devices: either the clause is directly governed by a preposition; or it constitutes a relative clause predicated of a possibly null instance of *ora* 'time', itself a complement within a PP. Only *tok* 'until' would seem to justify our enriching the possible values of C in Kriyol. Other types of relationships lead to the same conclusion. Take causal adjunct clauses, for example:

- (53) La ja tarbaju era menus purkë n bin obi  
 there already work be+PAST less because I and-then understand  
 ba ja kriyol. (I)  
 PAST already Kriyol  
 'There it was less work already because I had already come to  
 understand Kriyol.'
- (54) Suma no sta na tenpu di duburya... (HGTD)  
 as we be in time of drought  
 'As we are in a drought...'

In (53), *purkë* 'because', an acrolectal item whose 'deep' variant is *pabya*, can only, it seems, be generated under a C node, like its Portuguese source *porque*. *Suma* 'as', on the other hand, is also used as a preposition (as in, e.g., *fasi l suma mi* 'do it as I do'), so that structure (48) is licensed.<sup>28</sup> The same structure also provides for manner and purpose adjunct clauses:

- (55) Kunformu no na ba ta skirbi l asin ku no na ba ta minjorya l. (B)  
 according we A BA A write it so that we A BA A improve it  
 'According to how we are going to write it [Kriyol], we will  
 improve it.'
- (56) N ten di janti Kancungu pa Sines puy n  
 I have of go-straight-away Kancungu for Chinese put me  
 adezivu. (HGTD)  
 adhesive-plaster  
 'I've got to go to Cantchungo straight away in order for the Chinese  
 [doctors] to put adhesive plaster on my wound.'

*Kunformu* (also *konformi* — P. *conforme*) is certainly a preposition (*kunformu nya sintidu* 'according to my opinion'), and so is *pa* in (56), to be distinguished (at least synchronically) from complementizer *pa* we met earlier. There might be some doubt in (56) as to the finite character of the adjunct clause — compare its Portuguese equivalent *para os Chineses me porem um adesivo*, with an inflected infinitive. Given the above definition of finite prepositions, however, where the presence of an autonomous subject stands as the criterial feature, I will maintain that *puy* is indeed finite, and that the unmarked aspect being interpreted as a relative future is just another instance of the general principle of tense-aspect interpretation in embedded clauses (see above). Rule (49) must therefore be extended in order to cover *suma*, *kunformu*, *pa*, and doubtless other prepositions as well.

To the extent that **nunde** 'where' can be viewed as a nominal item, on the other hand, locative adjunct clauses take us back to the NP-plus-relative-clause type (Rule (51)). See the following example:

- (57) N na leba u nunde ku sancu ciw nel. (HGTD)  
 I A take you where that monkey be-much in+it  
 'I'll take you where there are lots of monkeys.'

Analysing **nunde** as being composed of **na** 'in' and **unde** 'where' gives us the following syntactic structure:

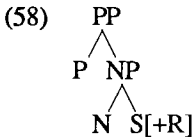

Although it is my feeling that **nunde** is much more frequent than simple **unde** (P. *onde*) in utterances such as (57), the latter is in no way excluded. In that case, the PP level would have to be erased and the locative reference entrusted to the lexical meaning of **unde**, now the head of an NP directly adjoined to the preceding VP.<sup>29</sup> I will return to these constructions in the following chapter in connexion with questions.

To conclude this section, something must be said about concessive adjunct clauses, a notoriously ill-defined category (see König 1988). In Kriyol, the only item specialized in concessivity seems to be **nin ku** (P. *nem que*) as in the following example:

- (59) Lubu nin ku bu nega l ka bu da l paja di dobra.  
 hyena not-even that you refuse it NEG you give it leave of pumpkin  
 'Even though you dislike the hyena, do not give it pumpkin leaves  
 [reputed for their bitterness].' (BPB)

It is not clear to me whether **nin ku** may be accommodated through Rule (51), or whether it should be generated entirely under C, with **nin** perhaps in specifier position. Since **nin** can hardly be considered nominal, the latter is probably the most plausible solution. And as we are talking about concessive clauses, this is as good a place as any to mention constructions such as the following:

- (60) Papyao papyo mortu ka seta ntindi kuma i ka lebri  
 speak O speak dead NEG accept understand KUMA it NEG rabbit  
 ku sinta la. (EG)  
 that sit there  
 'No matter what was said, the dead man refused to admit that it was  
 not the rabbit who was sitting there.'
- (61) Kumao kuma n na nbarka li. (MSNP)  
 how O how I A embark here  
 'No matter what, I will embark here.'

The **o** item appearing between both instances of a (presumably) non-finite (nominalized) verb or of **kuma** 'how' may well be the conjunction **o** meaning 'or' (P. *ou*). It may also be paralleled with the /o/ one finds in Mandinka within reduplications with roughly the same meaning, as in the following example (Rowlands 1959:157):

- (62) Wùloo ye ðibi-o-ðibi jé...  
 dog AUX shadow-O-shadow see  
 'Whatever dark shadow Dog sees...'

More probably, it is just both, another instance of the role of conflation in creolization processes.

### 5.3. Gerundive complements and comparative constructions

#### 5.3.1. Gerundive complements

The phenomenon is illustrated in example (52) above: **kaw kaba na sukuru son...** 'as soon as it was dark, ...'. Here is one more example:

- (63) I oja lubu na pasa. (I)  
 he see hyena A pass  
 'He saw hyena passing by.'  
 (64) Minjer say gora na cora. (I)  
 woman go-out then A cry  
 'Then the woman went out crying.'

These look like control constructions insofar as the unexpressed subject of the lower predicate (**na sukuru**, **na pasa**, **na cora**) is necessarily coreferential with an argument of the higher predicate, be it the subject as in (52) and (64) or the object as in (63). There are two crucial differences, however. First, the temporal relationship between both predicates is one of simultaneity, whereas controlled infinitives are typically interpreted as denoting a later event than that expressed by the main verb. This is obviously a consequence of the meaning of the aspectual auxiliary **na**, as well as the strongest reason for analysing it as such rather than as the homophonous preposition **na** 'in'. Note that the latter construal seems more natural, in contrast, in sentences like the following:

- (65) Ma tardi i ta kansa na aprendi kil lingwa.  
 more late he A tire in learn that language  
 'Later he would tire learning that language.'

Compare *i ta kansa na kil tarbaju* 'he would tire at that work', or the Portuguese equivalent *cansar-se-ia em aprender essa lingua*. This is not to deny that there may be borderline cases where deciding in favour of one analysis rather than the other would be difficult, if not impossible. Consider, for instance, the following:

- (66) *Kin ku panyadu na bibi mas di kil un litru i natomadu*  
 who that be-caught in/A(?) drink more of that one litre it A be-taken  
*midida duru.* (FJGK)  
 measures harsh  
 'Harsh measures will be taken against whoever is caught drinking  
 more than the [allowed] one liter.'

Secondly, the range of verbs admitting of *na+V* complements is both wider than the control verb category and partially disjoint from it, since modals like *misti* 'want', *pudi* 'can, may', etc. seem to exclude them. Of course, this will vary depending on the analysis one adopts in cases like (65) or (66).

Let us return to the (relatively) clear cases (63) and (64). An alternative analysis for (63) would be to construe *lubu na pasa* as a clause somehow dependent from the higher VP *oja* (perhaps a mixed category S and NP after Lefebvre and Muysken 1988). It won't hold, however, in view of the fact that *lubu* is indeed the object of *oja* as becomes obvious when it is pronominalized (*n oja i na pasa* 'I saw him passing by', not \**n oja i na pasa*).<sup>30</sup> It follows that *na pasa* does not have an autonomous subject, which makes it a non-finite form. Couldn't we analyse the sequence [*oja lubu na pasa*] as a serial verb construction (SVCs), however? Despite some dissensions, sameness of subject for all verbs in the series seems to be an unvarying character of SVCs, which suffices to exclude (63). Moreover, 'see passing by' or 'go out crying' are not the sort of unitary, if complex, events which constitute the semantic correlates of SVCs.

Non-finiteness and simultaneity thus lead me to propose that *na pasa*, *na cora* and the like should be analysed as gerundives fully parallel to their English or Portuguese equivalents 'passing' or *passando*, 'crying' or *chorando*.<sup>31</sup> The category was introduced earlier in connexion with *kuma*. Given this item's idiosyncrasy that it must be bare, temporal simultaneity in its case is inferred, presumably, from its denotational redundancy, *qua* abstraction of all *verba dicendi et intelligendi*, with respect to the higher verb. To put it more simply, the first verb and *kuma* denote the same event. This is of course not the case in (63), and simultaneity is explicitly marked through the Specific Imperfective aspectual auxiliary *na* (see Chapter 3). Otherwise, the syntactic structure of (63) and similar sentences may be considered identical to that we posited for *kuma* sentences, viz.:



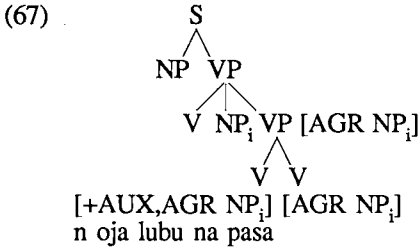

Likewise, (64) will be analysed with (68):

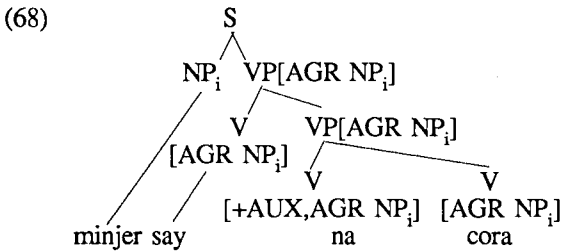

I will therefore conclude to the existence in Kriyol of a category 'gerundive', i.e. a non-finite VP made up of aspectual auxiliary *na* and a verb (the latter only in the one and only case of *kuma*), the unrealized subject of which is controlled by an argument of a higher VP (the subject only with *kuma*). Its function is to denote an event that is simultaneous with another event and included in it through the sharing of an argument. Simultaneity as opposed to posteriority is what distinguishes it from controlled infinitives (as in *n misti bay* 'I want [now] to go [later]'); inclusion as opposed to co-participation in a complex event is what separates it from serial verb constructions.

### 5.3.2. Comparative constructions

This is a rather intricate domain. Given what we know of other creole languages and of the substrate languages as well, we expect to find here some verb meaning 'surpass' in something like a serial verb constructions. Examples like the following seem to uphold that expectation:

- (69) Kacur mas ban sancu forti. (EG)  
 dog more PAST monkey strong  
 'Dog was stronger than Monkey.'
- (70) I ma si kunpanyeru sibi kusinya. (MC)  
 she more her friend know cook  
 'She can cook better than her friends.'

Not only does **ma(s)** (P. *mais* 'more') occur in the structural position of a finite verb governing an object, but it can be modified by the Past marker **ba** (**ban** in Ziguinchor).<sup>32</sup> Moreover, it obviously means 'surpass' in utterances like this:

- (71) Burgunyu mas el. (MM)  
 shame more him  
 'Shame overcame him.'

On the other hand, **mas** is undoubtedly not a verb (whatever its precise identity) in

- (72) I ba na pega mas formiga. (I)  
 he go A catch more ant  
 'He went catching more ants.'

As a verb, it does not assign Accusative case to its object, but Oblique as a preposition would. This can be seen in (71) and also in the following:

- (73) I mas mi ten forsa. (V)  
 he more me have strength  
 'He has more strength than I do.'

Monstrosities like \***burgunyu ma l** or \***ma n** are unthinkable. Although this makes **mas** look indeed like a preposition, it does not suffice to deny it its verbal status since there is at least one instance of a *bona fide* verb selecting Oblique case:

- (74) Pulisyas medi mi tudu. (HGTD)  
 policemen fear me all  
 'All policemen are afraid of me.'

As it is obviously a lexical peculiarity, such behaviour may be accounted for by assigning a special feature to **mas** and to **medi**, for instance [+P], meaning that those items do not govern their objects directly, but indirectly, through the intermediary of a lexically incorporated preposition-like element.<sup>33</sup> The syntactic structure of (71) and, presumably, of the first half of (73) would thus be the following:

- (75)
- $$\begin{array}{c}
 S \\
 \swarrow \quad \searrow \\
 NP \quad VP[+P] \\
 \quad \quad \swarrow \quad \searrow \\
 \quad \quad V[+P] \quad NP[OBL]
 \end{array}$$

The next question to answer is, what do we do with the second halves of (69), (70), and (73) ([ten forsa], [forti], [sibi kusinya])? A tempting move would be to treat them as the final parts of serial verb constructions, thus analysing, e.g. [ma si kunpanyeru sibi kusinya] as a complex predicate consisting of two finite VPs: [<sub>VP</sub> ma si kunpanyeru] 'surpass her friends', and [<sub>VP</sub> sibi kusinya] 'can cook'. I will resist the temptation, however, for two reasons.

First, that would be the sole instance of an SVC in the whole language, and it does not seem quite natural that Kriyol should make use of the construction for comparison only while systematically eschewing it for more typical semantic functions such as instrumentality. Admittedly, this is a weak reason. Secondly, the ordering seems wrong. What I mean by that is that there appears to be a strong measure of iconicity in the way the components of an SVC are ordered with respect to one another. For instance, no reversal is imaginable in prototypical instrumental or locative SVCs such as Haitian *li pran kouto koupe pen* 's/he cut the bread with a knife' or *li pran bèf-la ale mache* 's/he took the cow to the market', given the necessary temporal consecution of the sub-events composing the complex event denoted by the SVC. By the same token, we would expect the object of comparison, e.g. 'being able to cook', to precede the assertion of superiority if the latter is to be unambiguously interpreted as concerning the former. Incidentally, this is what we find in Principense (see above) or in Haitian (*li kab fe kwizin pase zanmi-y*), if it really is SVCs that we observe there. As it stands, what would prevent us from interpreting (70) as meaning that she betters her friends in some domain and she can cook? Perhaps this is an unlikely possibility and not a real problem. It is nonetheless suggestive, I think, that (all?) languages apparently using SVCs for comparison order the terms like Haitian does.

Now, another way of comparing entities is to first assert the superiority relative to some standard, and then express the domain in which the superiority obtains — thus producing something like 'A > B as for X'. To the extent that X is a predicate (e.g. 'be strong', 'be able to cook', etc.), this way of presenting things implies that the said predicate must be non-finite, i.e. not an actual event of X-ing, but the generic fact of X-ing. In Manjaku (see fn. 32) this is morphologically evident thanks to the *pě-* class marker on *-rëmb* 'be fat', the function of which is to nominalize verbal bases. *Upa a-pe Domingo përëmb* thus translates literally as 'Upa surpasses Domingo as for being fat'. Given the reasons adduced above for not adopting an SVC account, I will therefore assume that Kriyol goes like Manjaku, so that (70) is assigned the following tree:

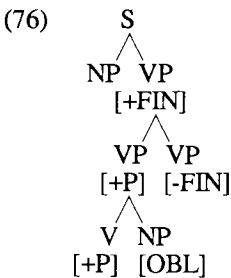

**Sibi kusinya** is thus analysed as a non-finite VP adjoined to the finite VP **mas si kunpanyeru**. The question of the shared subject does not arise since **sibi kusinya** is in fact a nominalization (or a 'verbal noun') which is not syntactically predicated of any entity — whereas it is readily understood as mentioning the domain in which the preceding predication takes its validity.

Such is, I will propose, the syntax of comparative constructions in basilectal Kriyol. It implies a partial reanalysis of Portuguese *mais* as a verb (partial, because **mas** also functions as a nominal element — see (72)) — a verb, however, which retains a preposition-like feature assigning Oblique case to its complement. Probably because of this feature and of the continuing non verbal use of **mas**, it was actually a short step from the basilectal construction to constructions more similar to what we find in Portuguese. For example, (69) can easily be reformulated as **kacur yera ba ma forti di ki sancu** — compare P. *Cão era mais forte do que Macaco*. Intermediate stages seem to be realized in the following examples:

- (77) I ma sedu kriyol propi di kil gosi. (I)  
 it more be Kriyol proper of that-one now  
 'It is more proper Kriyol than the one of nowadays.'
- (78) No ta ma ta pursibi ben na kaset di ki karta. (I)  
 we A more A understand well on cassette of that letter  
 'We understand better on a cassette than in a letter.'

Similarly, (70) could be expressed as **i ma sibi kusinya di ki si kunpanyeru**. Here it is clear that **mas** cannot be a verb. The simplest analysis, it seems, is to treat such constructions as instances of 'quantifier floating', with **mas** 'more' somehow adjoined to the left of the VP while having scope over an element to the right. As a consequence, of course, (70) must now be considered structurally ambiguous: it may either be analysed as in (76), or with 'raised' **mas** along with its complement, i.e. something like  $[_{VP}[_{PP} \text{mas si kunpanyeru}][_{VP} \text{sibi kusinya}]]$ . This potential ambiguity will probably have contributed as well to the shift from one construction to the other.

That said, it is not clear to me to what extent the 'deeper' and, presumably, older construction with **mas** a verb is now being superseded by the more 'Portuguese' one, nor even if it is being superseded.<sup>34</sup> Here is the place, again, for a careful sociolinguistic investigation.<sup>35</sup>



## Chapter 6

### Unbounded dependencies: topicalization, focalization, and questions

This chapter deals with syntactic constructions which have in common that two or more positions are linked across a distance in the sentence: a non-local domain. Hence the name ‘unbounded dependency constructions’ (UDC) which roughly covers the same ground as ‘movement’ does in transformational grammar. In addition to the topics mentioned in the title, the issue of raising verbs will be briefly dealt with — briefly because Kriyol presents mainly negative evidence on the subject.

#### 6.1. Topicalization

Topicalization may be defined as the construction whereby an expression, known (by the speaker at least) to be the topic of the ongoing discourse, is realized in a distinct position from the one it would be expected to occupy given its grammatical function — typically at the beginning of the utterance. The rest of the utterance then constitutes a comment or an information about the topicalized element. Two types may be distinguished according to whether the topicalized element is or is not represented within the comment. If it is, typically through a coreferential (resumptive) pronominal, one often speak of a ‘(left) dislocated’ construction, as in the following Italian example from Cinque (1990:14): *Gianni, lo ho visto* ‘I saw Gianni’; if it is not, topicalization *tout court* is often used as a label, as in this other Italian example, which forms a minimal pair with the preceding one: *Gianni ho visto* ‘Gianni I saw’ (ibid.). Note how the unresumpted topicalized construction implies a potential contrast, whereas dislocation highlights the object without necessarily contrasting it with other possible objects (also see Fradin 1988).

### 6.1.1. Topicalization without a resumptive pronominal

In Gazdar et al. (1985), unresumpted topicalization of the 'Gianni I saw' type is accounted for by means of the following non lexical ID rule:

- (1)  $S \rightarrow XP, H/XP$

That is to say, a sentence node may immediately dominate a maximal projection and another sentence from which the same maximal projection is missing. This is equivalent to the trace account of transformational grammar.

It is not clear to what extent rule (1) finds its application in Kriyol topicalized constructions. Consider the following examples:

- (2) Tudu ke ku na pasa el i ta sibi. (I)  
 all what that A happen he he A knows  
 'Everything that happens, he knows (it).'
- (3) E linya li, n bin bay bindi dinoti. (MJAP)  
 this line here I and-then go sell tonight  
 'This thread, I'll go and sell (it) tonight.'
- (4) Bu bin ngana n kuma nada bu ka mata. (HGCS)  
 you and-then deceive me KUMA nothing you NEG kill  
 'And you will have me believe that you killed nothing.'

Constructions of this type are not all that frequent in Kriyol, left-dislocation with pronominal reprise being what one normally observes (see below). When they do occur, as in (2) and (3), it seems in fact as if the verb in the comment part of the utterance was used intransitively, rather than transitively with a null direct object, as according to rule (1). In (2), for instance, *sibi* ought probably to be interpreted as 'know' in general ('be in a state of knowing') rather than 'know (something)'. In (3), as corroborated by other occurrences in the same story, the relevant expression is not *bindi* 'sell', but *bay bindi* 'go and sell', i.e. an intransitive expression.

Of course, this poses the problem of the grammatical function to be assigned to the topicalized element. Note first that it does not seem it could be anything but an NP, with specific reference as in (3) or quantifier-like denotation as in (2). APs are never topicalized in Kriyol (see, e.g., English 'Beautiful, she certainly is'). Neither do PPs appear in topicalized position, and resumption is obligatory in constructions involving a preposition (see below). We are thus left with NPs not visibly implicated in any kind of syntactic dependency. This, I would assume, is precisely what topicalization is about: the topicalized element is adjoined to the sentence that comments upon it and is not otherwise linked to it. As a consequence, the verb of the commenting sentence is used intransitively, both in the syntactic sense that there is no null object, and in the semantic sense that the denoted process does not affect an object but is merely somehow concerned with it.<sup>1</sup> Should Case

be considered a problem, nothing prevents us from providing the topicalized element with an inherent Case uniquely borne by expressions outside syntactic dependencies. We obviously need such a Case (or the grammatical function corresponding to it) for non-A pronouns (see Chapter 4) or topicalized subjects as in the following:

- (5) Nyu Parbay i tisidur di panu. (MJAP)  
 Mr Parbay he weaver of cotton-cloth  
 'Mr Parbay is a weaver of cotton cloth.'

The following is a particularly clear example where the topicalized element entertains a quite loose relationship, translatable as 'concerning' or 'as for', with the commenting sentence:

- (6) Kasamenti ku omi beju bu ta pirdi. (HGCS)  
 marriage with man old you A lose  
 'As for marrying an old man, you always lose.'

Again, no object need (and could) be reconstructed following *pirdi*. I will therefore propose that sentences such as (2) and (3) should be generated by rule (7), which does not make use of the SLASH feature:

- (7)  $S \rightarrow XP, H$

The fact that the topicalized XP is somehow concerned by the event denoted by H is then a semantic phenomenon to be expressed by an appropriate interfacing of morphosyntax and semantics, as possibly in (8):

- (8)

The intransitive interpretation shows up here as the semantic incorporation within the verb of the formula corresponding to the topicalized NP. In this way, *pirdi* in (6), for instance, is effectively interpreted as meaning 'lose', not in general, but in relation to the fact of marrying old men.

As for (4), a case of topicalization in an embedded sentence, the fact that it involves the negative quantifier *nada* 'nothing' raises special problems that will be dealt with later on in this section.

### 6.1.2. Left dislocation (LD)

This is by far the commonest kind of topicalization in Kriyol. Insofar as Kriyol is not a null subject language, all cases of subject topicalization such as (5) above may be considered instances of LD. Note there is no obligation for the dislocated



subject to be adjacent to the clause containing the resumptive pronoun. Witness the following example among countless others:

- (9) Ntori, bu ta pensa kuma i na buwa nan. (MJBA)  
 Ntori you A think KUMA he A fly NAN  
 'Ntori, you'd think he was flying.'

'Here are a few more examples with non-subject arguments:

- (10) Ami kontrada di minjer ka kiri n. (HGCS)  
 I meeting of woman NAG like me  
 'Me, going with women isn't good for me.'
- (11) Es minjer un byas n tisi l na nya kandonga. (HGCS)  
 this woman one time I carry her in my pick-up  
 'This woman, I carried her in my pick-up once.'
- (12) Na es kunpra polvora, la ku kunbersa kumsa nel. (MK)  
 in this buy gunpowder there that negotiation begin in+it  
 'It was at the occasion of this powder purchase that the talks began.'

The last example is a bit complex, as it involves focalization (see below) and double resumption: the locative adverb *la* 'there' plus the resumptive PP *nel* 'in it'. Although the whole PP *na es kunpra polvora* 'in this powder purchase' has been topicalized, this is not necessary, so that an equally grammatical unfocalized equivalent of (12) would be: *es kunpra polvora, kunbersa kumsa nel*, where only the NP gets topicalized.

A natural way of handling such cases in a PSG framework is to make use of rule (1) above, introducing a feature [+RES] (for resumptive) as another FOOT feature besides [+NULL] instantiated with SLASH, whereby it is understood that an expression terminating a UDC and bearing this feature must have exactly the same reference as the expression at the head of the UDC.<sup>2</sup> Hence the following FCR:

- (13) FCR: [+RES]  $\vee$  [+NULL]  $\Rightarrow$  [+SLASH]

licensing the following tree for, e.g., (11):<sup>3</sup>

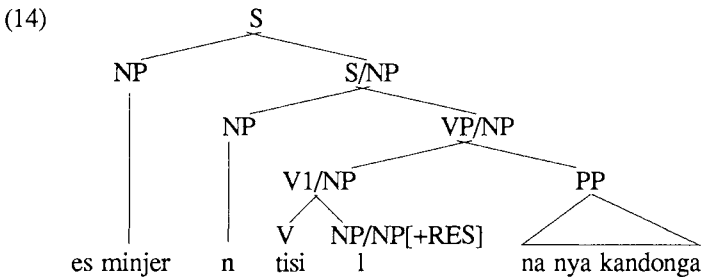

Fixing the value of SLASH at [+NULL] would generate ?*es minjer n tisi na nya kandonga* ‘This woman, I carried in my pick-up’, which I mark “?” because, although not ungrammatical, it is certainly not usual — mainly, it seems, because it is semantically undistinguishable from a much more common construction, viz. focalization (see below).

On the other hand, we might dispense with features altogether by assuming the relevant phenomenon to be the fact that the topicalized element and the resumptive expression, two units in the syntax, are actually one entity in the semantics, as represented in the interface below:

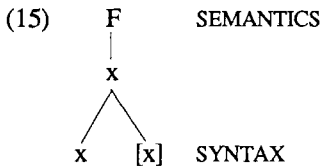

As noted with the square brackets, there should be only one (relevant) syntactic domain and the syntactic units must not share it. This suggests some converse of Principle B of the Binding theory, e.g. to the effect that an expression can have its reference determined by that of another expression — i.e. they can constitute a discontinuous expression with one semantic correspondent — only if the determining expression is outside the syntactic domain that the determined expression is in. Given interface (15), this straightforwardly implies that *x* must be the determining expression and [*x*] the determined one, that is an LD structure. The notion ‘have its reference determined by another expression’ is enough to restrict the application of the principle to pronominals and a few special terms (see fn. 2). This is why one cannot have as a converse of *es minjer n tisi l* ‘This woman, I carried her’, \**el n tisi es minjer* ‘Her, I carried this woman’, because the pronominal *el*, a determined expression by definition, is outside the relevant syntactic domain, when it should be inside. Of course, this is another way of formulating Principle C of the Binding Theory. But note it will not always do to bluntly state that ‘R-expressions are free’, given the acceptability of *Midana, n kungsi es minjer* ‘Midana, I know this woman’, which shows that c-command (or m-command) irrespective of the lexical definition of the items may not suffice to define binding. Also note that relative ordering is not specified and could not be, since the determining expression can well follow the determined one (*n tisi l na nya kandonga, es minjer*).<sup>4</sup>

I leave it to the reader to choose the explanation s/he prefers. As practical alternatives, they are fully equivalent. It is possible — actually it is my belief — that the style of the second one enshrines more promissory developments, in terms of cognitive adequacy, than does the first one.

### 6.1.3. Floating quantifiers and the null object issue

It is impossible to leave the issue of topicalization without broaching the subjects mentioned in the above title. Let us return to example (4) repeated below:

- (4) Bu bin ngana n kuma nada bu ka mata. (HGCS)  
 you and-then deceive me KUMA nothing you NEG kill  
 'And you will have me believe that you killed nothing.'

A similar case is (16), which we already met in a different connexion:

- (16) Es dus jintis bin pa mi sin nada n ka fasi elis.  
 this two people come to me without nothing I NEG do them  
 'Those two guys came for me without my having done anything to them.'

As already mentioned, such cases raise special problems. Viewing them as instances of what rule (7) generates is unsatisfactory insofar as (a) **mata** 'kill' or **fasi** 'do, make' are strongly transitive verbs that are almost never used without an object, contrary to **sibi** 'know' or **pirdi** 'lose'; (b) **nada** 'nothing' does not strike one as the kind of object (?) of which it can sensibly be said that the process (here of killing or of offending) is 'about' it. In other words, there seems to be a mismatch between **nada**'s undisputable capacity at being a syntactic object (e.g., **i ka mata nada** 's/he killed nothing', **i ka fasi nada** 's/he did nothing'), and its doubtful capacity at denoting an entity that could be affected by any kind of process. Actually **nada** (or 'nothing') has no reference at all. It is therefore a little strange that speakers would want to topicalize it, since it can hardly be a topic. The same remarks apply to related items which behave like **nada**, viz. **ningin** 'nobody', **nunka** 'never', and **nin un kaw** 'nowhere', that is to negative quantifiers denoting the null set in a particular section of the world.

On the other hand, deriving (4) and (16) by way of rule (1) feels uncomfortable too, because of the fact that **nada** and related items, and they only, can never be resumed. That is to say, **\*nada bu ka mata** I with SLASH fixed at [+RES] rather than [NULL] is hopeless. Now, this seems to run counter to the option taken in (13) of having [+RES] an alternative value of SLASH, meaning that we would expect [+RES] to be possible whenever [+NULL] is and vice-versa.<sup>5</sup> In the other explanatory style proposed above, this would mean that one of the two syntactic positions of (15) should be free to be phonetically realized or not. But with **nada** and the like occupying one position, the other must be unrealized.<sup>6</sup>

Solutions to this problem exist in the transformationalist framework: move **nada** — analysed as the negative equivalent of **un kusa** 'something', i.e. as a quantified NP — from its DS position under VP to some higher node (see Sportiche 1988 for a review and a new proposal), leaving a trace interpreted as a

variable in LF. The impossibility of resumptive pronouns could then be viewed as indicative of the fact that pronominals cannot be interpreted as variables the value of which is never fixed because the quantified NP that binds them has no reference. Variables or not, pronominals must end up with a reference. This means that the brunt of the account is semantic in character. So would it be, I suppose, within a PSG framework. The positioning of *nada* could be provided for by either rule (1) or (7), but the real explanation would have to come from the semantic make-up of the item.

This being so, I will propose an explanation that is unashamedly semantic, in terms of parallel representations. The crucial observation is that *nada* is not the semantic object of the predicate which seems to contain it. Consider indeed the logical representation of *bu ka mata nada* ‘you killed nothing’ (or, better perhaps, ‘you didn’t kill anything’):

(17)  $\neg \exists x$  (mata(x)) (bu)

reading as, ‘there is no thing x such that you killed it’. (I abstract, as I think we may, from ‘negative concord’ for which see Chapter 2.) *Nada* appears thus as the lexical spell-out of the formula  $\neg \exists x$ , with x a non-person, and similarly *ningin* with x a person, and so forth.<sup>7</sup> The claim that it is not the semantic object of the predicate becomes then obvious, since the role is taken by x. The following tree representation makes this point clearer (see Sadock 1991 for the formalism):

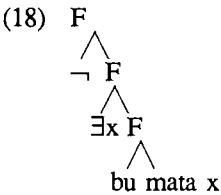

Consider now that both x’s in (18) should be viewed as making up one discontinuous argument as in (15). The same principle will then hold, namely that, interfacing semantics with syntax, either one occurrence may be lexically realized ‘in full’ while the other appears as a resumptive element or not at all. With a difference, though. Suppose the first x is retained for full realization. Two semantico-syntactic interfaces are then conceivable:

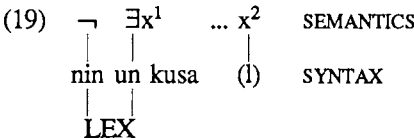

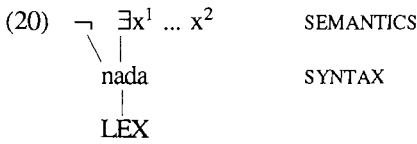

Interface (19) represents one-to-one correspondence between the elements of the semantics and those of the syntax, with independent lexicalization for each. (The graphic positioning of LEX is destined to suggest the orthogonality of the lexicon vis-à-vis the other modules.) Here, as mentioned in footnote 7, the second component of the discontinuous expression may be realized as a resumptive pronoun or have no syntactic correspondent. In other words, (19), representing **nin un kusa bu ka mata** (I), corresponds to ordinary LD, with or without a resumptive element (see fn. 5). Of course, this has to do with the fact that **kusa** 'thing' is a normal lexeme that nothing can prevent from being referred to by a pronominal. In (20), in contrast, one-to-one correspondence is disrupted since  $\neg$  and  $x$  get conflated into one lexeme, **nada**. With the consequence that the discontinuous expression [ $x^1 \dots x^2$ ] is also broken: once  $x^1$  has been absorbed with  $\neg$  into **nada**, no antecedent remains for  $x^2$  in the syntactic module. To state it the other way, no pronominal can have its reference determined by **nada**, because pronominals have their reference determined by NP type expressions (including propositions), and **nada** is not an NP type expression denoting some entity but the lexicalization of the predicate  $\neg\exists x$  'there is no thing'.<sup>8</sup> The unacceptability of **nada bu ka mata** I is thus explained in a, I think, natural and effective way. It follows from this argument that (4) and (16) are not instances of topicalization or LD, but indeed cases of quantifier floating explicated as direct interfacing of the semantic and syntactic modules. The interpretive result is actually focalization, meaning here emphasis. **Nada** in (4) and (6) must bear (at least some) contrastive stress, contrary to **es minjer** in (11). Direct interfacing is also what explains that **nada** (or **ningin**, etc.) must immediately precede the clause with which it is interpreted. Indeed, in order for syntax to be isomorphic with semantics, the syntactic tree corresponding to and interfaced with (18) must have the following shape:

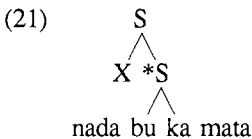

I use the device of starring the lower S to underline the fact that it is indeed ill-formed within the syntactic dimension, since it does not meet the subcategorization requirements of its head. Hence, it is only through interfacing

with the semantic representation that the actual expression will finally receive the acceptance label. This is an interesting feature of the parallel representation model, already emphasized, that an expression does not have to be well-formed in all and every module or dimension.

An empirical consequence of this analysis is that, although (21) looks very much in outline like the syntactic tree associated with (11), there is no way of intercalating material between **nada** and the lower S. One cannot say \***nada bu bin ngana n kuma bu ka mata** on the model of (9) (**Ntori bu ta pensa kuma i na buwa**). Here is, I think, a clear reflection of the fact that in (4) the shape of the utterance reproduces the necessary semantic configuration of an expression involving a non-existence predicate such as **nada**, while (11) manifests a much freer operation that can be performed on linguistic material in the syntactic and semantic modules.

What about the other possibility, viz. retaining the second position for full lexicalization? It corresponds to the following interface:

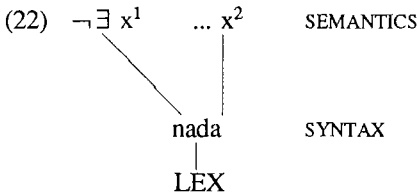

describing **bu ka mata nada**. Interface (22) accounts for two things: (a) the fact that **nada** is not the semantic object of the verb even when it seems to be realized in the position of a syntactic object; (b) the fact that  $x^1$  cannot then be realized (one cannot say \***el<sub>i</sub> bu ka mata nada<sub>i</sub>**) which is not explained by Principle C (as is, to a certain extent, \***el<sub>i</sub> n tisi es minjer<sub>i</sub>**— see above) since **nada** is not a referring expression. The simple explanation is, like before, that  $x^1$  is not the same thing as  $\neg x^2$ .

A related problem is exemplified by the following sentence:

- (23) Kacur tudu kaw ku i oja sancu i ta serka pa panya. (I)  
 dog every place that he see monkey he  $\wedge$  chase for catch  
 'Wherever he sees him, Dog chases Monkey to catch him.'

Here seems to be a clear case of null object since there can't be any doubt that the intended meaning is that Dog chases Monkey to catch Monkey. Note first that, as far as syntactic structure is concerned, (23) cannot be compared with (2), since it is not the virtual object of **serka** and **panya** that is topicalized, but the whole locative NP (**tudu kaw ku i oja sancu**) containing this object. That is to say, the syntactic structure of (23) looks like this:

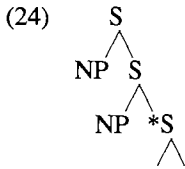

Again, the lower S (or rather the two lower S's **i ta serka** and **pa panya**) deserves starring since the subcategorization requirements of both head verbs are not fulfilled. How then do we know that 'chasing' and 'catching' are about Monkey? Notice that binding or establishing a UDC won't do since there is no obvious structural relationship between **sancu** 'monkey' and the virtual object positions after the verbs. (For instance, **sancu** does not c-command or m-command these positions.)

An important observation is that the possibility of such a construction seems to depend crucially on the iterative, i.e. non-specific, meaning of the whole expression, as manifested by the non-specific imperfective **ta** and by the quantifier-like locative NP **tudu kaw ku...** 'wherever...'. Suppressing this feature, as in **\*kacur, oca i oja sancu, i serka pa panya** 'Dog, when he saw Monkey, he chased (him) to catch (him)', makes the sentence unacceptable or, at least, markedly deviant as compared with the perfectly normal **kacur, oca i oja sancu, i serka l pa panya l**. Given this, I will assume that (23) can be compared with (2) after all, insofar as the lexemes 'chase' and 'catch' do not denote specific events affecting a specific entity, but generic instances of the events having to do with the said entity. That is to say, I will assume that **serka** and **panya** are used intransitively, just like **sibi** in (2). (23) is thus not a case of topicalization, but another illustration of rule (7) whose import can now be seen as merely to provide for the fact that material can be adjoined to a sentence. The relevance of this material for the sentence — e.g. the fact that 'chasing' and 'catching' are about Monkey — is then not a matter for syntax to decide (since there may well be no specific syntactic relationship between both), nor even for logical semantics, but for what I would call 'practical inference'. With verbs whose meaning is such that they can easily be used intransitively, like **sibi** 'know', the relevant configuration is rather routinely realized. With strongly transitive items like **serka** and **panya**, on the other hand, very special discursive conditions must be fulfilled as in (23).

Another interesting aspect of (23) is that reprise pronouns may indeed be supplied, but with a definite pattern for grammaticality, as illustrated:<sup>9</sup>

- (25) **Kacur tudu kaw ku i oja sancu i ta serka l pa panya l.**  
 (25') **Kacur tudu kaw ku i oja sancu i ta serka l pa panya.**  
 (25'') **\*Kacur tudu kaw ku i oja sancu i ta serka pa panya l.**

Both verbs can be followed by a pronoun, or only the first one can, but not the second one only. Such a constraint might suggest that we have something like a parasitic gap construction here, meaning that the gap after **panya** in (25') would be OK because licensed by the preceding c-commanding pronoun, whereas the gap after **serka** in (25'') would be unlicensed.<sup>10</sup> Except that, if the preceding analysis is on the right track, there is no gap in (23), and consequently in (25') and (25''), but simply nothing. We therefore need a different explanation.

I will surmise that **serka pa panya** in (23) is semantically reanalysed as a single intransitive predicate, meaning 'chase-to-catch', somehow after the fashion of **bay bindi** in (3). In (25), the reanalysis does not occur, and both verbs are autonomous transitive predicates. In (25'), on the other hand, there is partial reanalysis in the sense that **serka** is a transitive predicate, but **panya** is treated as a secondary predicate being 'about' the event fully denoted by **serka** I 'chase him'.<sup>11</sup> The whole point is then that (25'') is semantically anomalous; you don't normally enunciate a secondary predicate before presenting the full one on which it depends for its interpretation.<sup>12</sup>

## 6.2. Focalization

I use this semantic or 'functional' label to designate a construction that is commonly referred to as 'clefting' ('highlighting' is another apt label — see Holm 1988). What it does is to single out an element of a set, and then to predicate something of it, with the implication that the property thus predicated holds only of that element, not of any other element of the set of which it might have held a priori. Hence, probably, the frequent biclausal nature of focalized constructions, comprising first an identificational clause (the singling out component), then followed by a relative clause (the predicative component). English clefts are of course especially transparent examples of this general pattern. For instance, 'It's a black horse that he bought', while presenting the syntactic structure just delineated, does indeed imply that of all the horses he might have bought, only the one he bought has the property of being black.<sup>13</sup> But Wolof *fas wu ñuul la jënd* /horse CLASS+DET be-black FOC+3SG buy/ 'It's a black horse that he bought', although superficially rather different from English, can be shown to be in fact quite comparable with it (see Kihm 1991). I give now a few Kriyol examples:<sup>14</sup>

- (26) Kil ku ta say di boka, kila ku ta bidanta omi susu. (V)  
 that that A exit from mouth that-one that make-become man dirty  
 'That which comes from the mouth, it is that which soils the man.'
- (27) I ka anos ku puy u bu pirdi kurida. (FJGK)  
 it NEG we that make you you lose race  
 'It's not us who made you lose the race.'



Example (26) has been selected for its clarity concerning the semantic function of focalization. The syntax of the construction is shown more fully in (27), however. Note the identificational clause consisting of the 3rd person singular subject pronoun *i* 's/he/it' followed by a noun predicate (see Chapter 2), itself heading a relative clause (see Chapter 4). In (27), due to the presence of the negation *ka*, a verbal item (see Chapter 2), the subject of the predicate is obligatorily present. It could be present in (26) as well (*i kila ku ta...*), yielding a perfectly synonymous expression, but it is as a matter of fact quite often absent in non negative focalized constructions. This is easily accounted for. Recall that Kriyol noun predicates are licensed by the following ID rule, assuming free assignation of the [+PRD] feature:

$$(28) S[+PRD] \rightarrow NP, H[+PRD]$$

where H is NP. All we need now is a rule such as

$$(29) S[+PRD] \rightarrow H[+PRD]$$

saying that a predicative sentence may consist of nothing more than an NP with a predicative feature.<sup>15</sup> That this NP may itself dominate a relative clause predicated of its head is a matter of course, that has already been provided for. The following tree for (26) is thus licensed

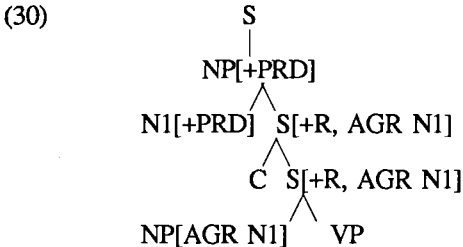

The tree for the 'full' variant with *i* (*i kila ku ta...*) is identical but for the top part:

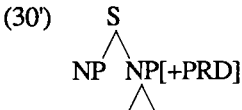

Rule (29) must of course be coupled with a semantic formula for focalization, which may have the following form:

$$(31) \lambda x P(x) \ \& \ \forall y \neq x \lambda y \neg P(y)$$

meaning the property of being an *x* with property *P* and such that nothing else has property *P*. Replacing variables with constants and considering that the implied contrast is normally within a certain set of objects to which the focalized item belongs, we can rewrite (31) as

(32)  $P(a) \ \& \ \neg P(\{A\}-a)$

where  $(\{A\}-a)$  designates the set to which  $a$  belongs minus  $a$ . This can be interfaced with syntax in the following way:

(33)         $a$          $P$          $(\& \ \neg P(\{A\}-a))$   
               |            |  
               NP[+PRD] S[+R]

with the implied contrast remaining entirely implicit. Under this view, it is the 'elliptic' version where focalization is syntactically marked by nothing but the initial position of the focalized term and the relative complementizer *ku* that follows it (and intonation of course), that appears basic, and the full version the result of making predication explicit according to the rules of the language, sometimes as an optional variant as in (26), sometimes obligatorily as in (27). Note that this agrees quite well with the probable historical origin of the construction. Indeed, (26) would be rendered in Portuguese as *aquilo é que suja o homem*, where *é que* 'is that' constitutes, to all intents and purposes, a fixed expression.<sup>16</sup> Supposing it to have been the input to creolization, *é* was bound to get lost, giving rise to such constructions as (26).

Subjects are focalized in (26) and (27). There is no restriction, however, on the type of arguments that can be subjected to the operation. Here are a few more examples:

- (34) Pis garandi son ku i ta da n pa n kume. (MM)  
 fish big only that he A give me for I eat  
 'It's only big fish that he gives me to eat.'
- (35) Nin si fin du mundu ku bu bay n na bin bo tras. (HGRB)  
 not-even if end of world that you go I A come your behind  
 'Even if it's to the end of the world that you go, I'll come after you.'
- (36) Kakri na oja kuma ku dus dinti ku n murdi u. (MM)  
 crab A see KUMA with two tooth that I bite you  
 'Crab will see that it's with two teeth that I bit you.'
- (37) I ka li ku n sina obi kriyol. (I)  
 it NEG here that I learn understand Kriyol  
 'It isn't here that I learned Kriyol.'

A direct object is focalized in (34); an unaffected object in (35); a PP in (36); and a locative adverb in (37). In (36), focalization occurs in a sentence embedded under *kuma*, i.e. in a subordinate sentence without a complementizer (see Chapter 5). The point to be noted is that, should a complementizer be present, focalization would no longer be a possible option, so that, e.g., *\*kakri misti pa ku dus dinti ku n murdi u ??* 'Crab wants that it should be with two teeth that I bite you' is even worse than its English gloss. Supplying *i* (*\*kakri misti pa i ku...*) does not improve matters. This should not be taken as a ban against focalized constructions

in clauses having a complementizer at their head, as shown by (35). In other words, the explanation has nothing to do, it seems, with purely syntactic factors, such as the C position being already occupied, as might be imagined. I will rather assume that some semantic constraint is at work here, which I will not try to elaborate, however, not to protract the argument beyond reasonable limits.

On the other hand, focalization is perfectly compatible with topicalization, as in the following example:

- (38) Abo mufunesa ku bu na buska. (MM)  
you trouble that you A search  
 'You, it's trouble that you are looking for.'

Finally, focalized constructions must be distinguished from what might be called 'identificational' sentences such as this:

- (39) I nya omi ku ta kay son. (MM)  
 it my man that A fall only  
 'It's only my husband who's falling.'

and it is a fact that 'omitting' *i* is a sure way of disambiguating such utterances. That is to say, whereas (39) is ambiguous between the focalized and the identificational interpretations, **nya omi ku ta kay son** can only mean that it's only my husband, and nobody else, that is falling. (The scope of **son** 'only' will also differ according to the reading.)

### 6.3. Questions

It is only natural that the study of questions should follow on the heels of that of focalization since Kriyol is a language where question words (henceforth Q-words) are obligatorily focalized, as illustrated in the following examples:<sup>17</sup>

- (40) Kin ku fala u sin. (FJGK)  
 who that say you so  
 'Who told you so?'
- (41) Ke ku bo misti. (MJAP)  
 what that you[PL] want  
 'What do you want?'
- (42) Kuma ku n na fala l propi. (MJAP)  
 how that I A say him exactly  
 'How will I tell him exactly?'
- (43) Kal ŝeki ku ta tene kara di pekadur. (FJTN)  
 which cheque that A have face of person  
 'What cheques have people's faces (on them)?'
- (44) Nunde ku n puy saku. (FJTN)  
 where that I put bag  
 'Where did I put the bag?'

- (45) Nunde ku es bandidus bay nel. (FJTN)  
 where that this bandits go in+it  
 'Where did those bandits go?'  
 (46) Kantu byas ku n kontu u. (FJGK)  
 how-much time that I tell you  
 'How many times did I tell you?'

In all these sentences, 'fronting' without focalization would lead to ungrammaticality (*\*kin fala u sin*, *\*ke bo misti*, *\*kuma n na fala l*, and so forth). Having the Q-words in their argumental positions (so-called 'WH-in-situ'), on the other hand, yields echo questions, just like in English.<sup>18</sup> For instance, *bo misti ke* 'You want what?' instead of *ke ku bo misti* does not convey a request for information but, usually, indignation at some preposterous desire that the other party in the interaction just expressed, and the speaker heard perfectly well.

There is one case, however, where focalization is normally avoided, and that is when the verb would have to be the present copula. The Q-word is then treated as a predicate NP, as in the following example:

- (47) Un son i kantu. (FJGK)  
 one only it how-much  
 'How much is one?'

The focalized equivalent, *kantu ku un son (i) sedu* /how-much that one only (it) be/, although not outright ungrammatical, sounds highly unidiomatic.<sup>19</sup> Similarly, one finds *el i kin*, literally 'S/he, it's who?' and *es i ke* 'This it's what?' as the only possible constructions for enquiring about the identity of somebody or something. See also *di bo i kal* /of you it which/ 'Which one is yours?', and *saku i nunde*, literally 'The bag, it's where?' as a 'clipped' equivalent of *nunde ku saku sta (nel)*.

A propos this latter expression and (45), it is apparent that the argumental position of the Q-word may be occupied by nothing or by a resumptive pronoun. The option is only open, however, when the Q-word is (or can be viewed as being) in a PP. It is utterly excluded to have a resumptive pronoun in, e.g., (41) (*\*ke ku bo misti l*). When the PP is overt — i.e. when the Q-expression has the form [P-Q] instead of *nunde* — the choice is between pied-piping without resumption (*ku ke ku bu suta l* /with what that you hit him/her/ 'With what did you hit him/her?') and no pied-piping with resumption (*ke ku bu suta l kel* /what that you hit him/her with+it/ 'What did you hit him/her with?'), the second variant being perhaps a little more common. Pied-piping with resumption (*\*ku ke ku bu suta l kel*) or no pied-piping without resumption (*\*ke ku bu suta l*) are both ungrammatical.

Except for obligatory focalization and the use of resumptive pronouns, Kriyol facts appear thus to be quite similar to those of English — or of Portuguese.<sup>20</sup> The question to be asked, then, is why is focalization obligatory? Why isn't fronting —

through WH-movement or some non-transformational equivalent — good enough? The answer I would like to propose is that (a) Q-words are predicate NPs as a matter of definition; (b) Kriyol, to the difference of, e.g., English, happens to have its (parochial) syntax isomorphic to (universal) semantics in this domain (see Kihm 1990 for a more thorough exploration of this line of thought; also see Karttunen 1977). If this is accepted, it won't be necessary for us to take sides in the debate whether such structures as (40)-(46) are base-generated or transformationally obtained, simply because the alternative will then appear to be devoid of meaning.

Point (a) implies that the semantic representation of a Q-word is not that of an ordinary common noun like 'computer', i.e. not like (48) (see Sadock 1991):



but rather like (49):



In (49), ? is an operator that may be glossed 'what is', i.e. it queries about the identity of what it has in its scope. What it has in its scope is a variable  $x$ , identified not by a particular lexeme as in (48), but by a set ranging over an indefinite number of lexeme unified by a common feature. Such features are well-known: [+PERSON] giving rise to 'who', [-PERSON] giving rise to 'what', and so forth.<sup>21</sup> The F left dangling in (49) is the proposition predicated of the entity that is being inquired about. Thus, (49) can be rewritten in a logical format as

$$(50) \quad ?x: x \in \{A\} [\lambda x P(x) \ \& \ \forall y \neq x \lambda y \neg P(y)]$$

the right-hand part of which is recognizably the formula for focalization, since asking 'Who came?' necessarily carries the implication that of all the members of the relevant set of whom the proposition 'x came' might have been true, it was at least or only true of a certain subset (or so the asker believes), and it is about the identity of this subset that the asker inquires.

Obligatory focalization will then follow from interfacing semantics with syntax in the most direct way:

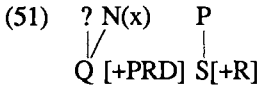

The feature [+PRD] can be seen as the syntactic reflex of keeping the question operator ? and its argument N(x) separate in the lexical definition of Q-words. As a consequence, *kin*, *ke*, etc. cannot be syntactically inserted as simple NPs, but only as heads of predicative sentences, which is why a relative clause, not a VP, has to be predicated of them. The syntactic structure of *kin ku fala u sin* 'Who told you so?' is thus identical to that of its possible answer (i) *el ku fala n sin* 'It's him/her who told me so'.<sup>22</sup>

Of course, their inherently predicative character explains why Kriyol Q-words can be inserted in predicative structures such as *es i kin* 'Who is it?' without more ado. In that case, of course, a full sentence has to be constructed in accordance with rule (28) above. With the implication that rule (29), the 'elliptic' variant of (28), will only apply when the predicate character of the head is syntactically apparent elsewhere, for instance because it is followed by a relative clause rather than a VP. (Although I've been very discreet about it, it is clear that intonation plays a crucial role as well.)

The echo character of Q-words in argument position, on the other hand, is readily explained if one considers again that echo questions are precisely not questions.<sup>23</sup> That is to say, in a language like Kriyol where homomorphic semantics-syntax interfacing is the rule in this domain, the fact that it is infringed is enough to show that the Q-word is not used as such, but as a place-holder for a chunk of other's discourse that the current speaker is challenging rather than questioning. Of course, not any old word would do. If Q-words are used to the exclusion of anything else, it is because there is still a sense in which a question is being asked — but a question which, like 'Do you have the time?', is a request for action (repeat, amend, etc.) and not for information (on this, see Goffman 1981).<sup>24</sup>

As for the constraints on resumption, let us look at the syntactic structure of (41) *ke ku bo misti* 'What do you want?':

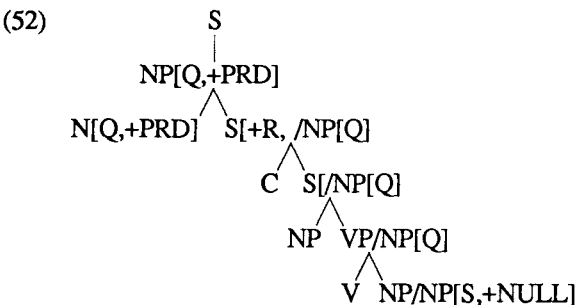

What is the relevant difference between this structure, with SLASH obligatorily [+NULL], and that of a dislocated sentence with SLASH obligatorily [+RES] (e.g. *es minjer, n tisi l* 'This woman, I carried her')?<sup>25</sup> One might think it to be the fact that the lower S has a C (complementizer) value in (52), but none in the other case, so that the value of the feature would correlate with the presence vs. absence of a complementizer.<sup>26</sup> But then, one would stumble on the no less certain observation that resumption is indeed possible in focalized sentences, be they interrogative or not, provided the focalized element is a PP or *nunde* 'where'.<sup>27</sup> This, however, can be reconciled.

Let us assume that the value of SLASH does indeed depend on whether the sentence containing it is embedded or not. We thus have the following FCR:

(53) FCR: [SLASH, +NULL]  $\Rightarrow$  [+C]

What (53) says is that a null element can only occur in an embedded sentence, so that resumption will be the only recourse in topicalized constructions. It does not say that only null elements can occur there; in other terms, it does not exclude resumptive pronouns from embedded sentences, but it leaves them as the elsewhere case. Let us look now at the syntactic structures of (44) and (45). Apparently *nunde* 'where' can be analysed as an NP or a PP, perhaps depending on whether the morphological composition /na+unde/ is projected into the syntax or not. The second option is exemplified in (44) with the following (simplified) structure:

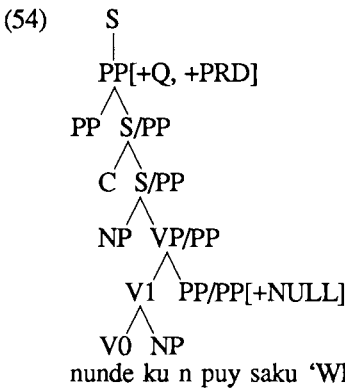

In accordance with (53), SLASH, having here the maximal projection PP as its categorial value, is assigned [+NULL]. Consider now (45), assuming it to instantiate the first option viz. taking *nunde* to be an NP. The following structure ensues:

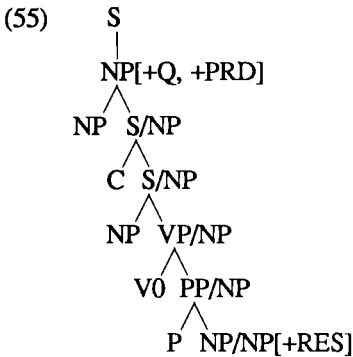

nunde ku es bandidus bay nel 'Where did those bandits go?'

Normally, /NP should be valued as [+NULL]. But doing that would leave us with an intransitive preposition — a perfectly good object in English, but an impossible one in Kriyol. Hence, SLASH must be [+RES] in order to satisfy the selection requirements of the preposition. Why does the argument not apply to (44)? The reason, I will propose, is that, although *puy* subcategorizes for two complements (*puy X na Y* 'put X in/on Y'), Kriyol verbs may be used intransitively given the right syntactic or discursive conditions, as shown above. It is a peculiarity of Kriyol grammar (which it shares with many languages), on the other hand, that prepositions must have an expressed object. In line with the general idea that grammars differ mainly at the level of the morphosyntactic interface, I will further surmise that this is a morphological property, expressible in a definition of Kriyol prepositions as clitics (whereas English prepositions would be words).

We cannot leave the domain of questions without returning to an issue that was already touched upon in a preceding chapter (see Chapter 3), viz. that predicate Q-words, to the difference of other predicate NPs, cannot have the Past adverbial *ba* appended to them:

- (56) \*Kil omi i kin ba. (AK)  
 (57) Kil omi ba i kin. (AK)  
       thatman PAST he who  
       'Who was that man?'

As shown by (57), *ba* must then be appended to the topicalized element, with normally a pause between it and the following nominal clause.<sup>28</sup> In order to account for this surprising phenomenon, we must reflect on the meaning of the English gloss 'Who was that man?'. This question is in fact ambiguous between two interpretations, one rare, even far-fetched in the present context, the other



common. In the rare interpretation, 'Who was that man?' inquires about the past identity of 'that man', thus implying that some basic change occurred 'in' him.<sup>29</sup> The common interpretation, in contrast, could be reworded as 'Who is that man who was there?'. That is to say, the question is not at all about the past identity of a supposedly changed person, but about the past location — relative to the speaker's present whereabouts — of a now absent, but otherwise unmodified person.

What Kriyol does, then, is merely to overtly construct the question as it is in fact understood. That it can do thanks to the adverbial character of the Past 'marker'. *Kil omi ba* is thus structurally no different from *kil omi la* 'that man there'.<sup>30</sup> Moreover, native speakers agree in considering *kil omi ba* a 'shortened' version of *kil omi ku sta ba la* 'that man who was there'. I will therefore assign it a structure like the following:

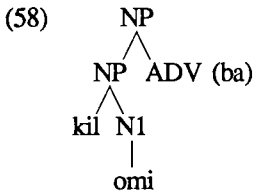

and assume that it is related to the structure for *kil omi ku sta ba (la)* through 'pruning' of the nodes intervening between N1 and the tense adverb, whereby 'pruning' should be understood as the operation of a metarule or — better perhaps — of a meaning postulate. Consider indeed that, once realized, *kil omi ba* (or an equivalent) not only can, but must be used as the topicalized element of a question directed at its identity.<sup>31</sup> There is no way one can say such things as *\*kil omi ba i mata si minjer* to express that the man who was there (a moment ago) killed his wife. The full relative clause *ku sta ba la* 'who was there' must then be used. Similarly, there is no possibility for *kil omi ba* to be interpreted as 'that man who Xed', with X another verb than *sta* 'be in a place'. Hence the assumption that it must be something about the very questioning about identity which allows the equivalence of the full and the 'pruned' expression. Perhaps it has to do with the accepted concept that, in the unmarked case, identity is a constant, which forbids *\*kil omi i kin ba*, so that *kil omi ba i kin* appears as the closest equivalent not requiring additional lexical material, but with the common interpretation of 'Who was that man?' Note to conclude that the uncommon interpretation is attainable in Kriyol, but it requires the copula: *kil omi i yera (ba) kin*, which is ambiguous.

#### 6.4. Expletive subjects and raising verbs

The one thing one can say about raising verbs in Kriyol is that they do not exist. Consider the following sentence:

- (59) I *parsi* n kuma kil fulanu ka ta obi kriyol. (I)  
 it seem me KUMA that so-and-so NEG A understand Kriyol  
 'It seems to me that this guy doesn't understand Kriyol.'

The 'raised' English equivalent 'This guy seems to me not to understand Kriyol' is totally impossible in Kriyol.<sup>32</sup> The subject pronoun can be unrealized, on the other hand, as in

- (60) *Parsi* n kuma no ka ten ja mafe. (HGCS)  
 seem me KUMA we NEG have already mafe  
 'It seems to me we haven't got any mafe any more.'

This is the only case where a Kriyol finite verb may appear with what looks like a null subject. *Parsi* 'seem' should therefore be singled out in the lexicon, for example by providing it with a feature [SUBJECT *i* <+EXPL>], plus the provision that an expletive subject, i.e. a subject that is there only to fill up a position, can be left unrealized. Note there is no sense in which *i* can be said to share in reference with the clauses *kil fulanu ka ta obi kriyol* or *no ka ten ja mafe*. Indeed, these clauses play no semantic role whatever vis-à-vis *parsi* itself (in another theoretical dialect, *parsi* does not assign any theta-role to them or to *i*). The semantic representation of (59)-(60) will thus be something like (61), where *parsi* is analysed as a sentential operator mapping a proposition into another proposition (abstracting the clausal nature of *kuma* — see Chapter 5):

- (61)
- $$\begin{array}{c}
 F \\
 \swarrow \searrow \\
 O \quad F \\
 | \quad | \\
 \text{parsi} \quad \text{kuma...}
 \end{array}$$

*Parsi*'s subject is entirely a creature of syntax, which is presumably why it can be dispensed with.

Things are a little different, however, in other cases where one is tempted to suspect the presence of an expletive subject. Consider the following examples:

- (62) I ka ten problema. (I)  
 it NEG have problem  
 'There's no problem.'
- (63) I ka sobra mas nada. (I)  
 it NEG remain more nothing  
 'There isn't anything left.'

- (64) No na aviza publikukuma i ciga awos un delegason di Senegal.  
 we A inform public KUMA itarrive today a delegation from Senegal  
 'We inform the public that there arrived today a delegation from Senegal.' (RB)
- (65) Manga di byas i ta muri mames o se fijus na ora di padi.(RB)  
 lot of time it A die mothers or their children in time of give-  
 birth  
 'Many times mothers or their children die at the moment of birth.'
- (66) Kin ku panyadu na bibi mas di kil un litru, i na tomadu  
 who that be-caught A drink more of that one litre it A be-taken  
 midida duru. (FJGK)  
 measures harsh  
 'Harsh measures will be taken against whoever is caught drinking  
 more than the [allowed] one litre.'

The difference with (59)-(60) is that all these sentences have variants where the material following the verb replaces *i* in the subject position: **problema ka ten; nada ka sopra mas; un delegason di Senegal ciga awos; mames o se fijus ta muri; midida duru na tomadu**. Moreover, despite the apparent object position of this material, the verbs involved in (62)-(66) and similar cases are all intransitive, either clearly inaccusative (*ciga* 'arrive'), or arguably so (*ten* 'have, there is', *sobra* 'remain', *muri* 'die'), or passive (*tomadu* 'be taken'). Given the Unaccusative Hypothesis (Perlmutter & Postal 1984; Burzio 1986) and standard assumptions about semantic roles, this entails that, e.g., **un delegason di Senegal** in (64) is indeed an internal argument of *ciga* as well as to some extent an affected Patient (this is of course clearer in (65)). In the active version of (66), **midida duru** would likewise be the object of *toma* (**e na toma midida duru** 'They will take harsh measures'). Finally, we observe the well-known definiteness effect: all objects in (62)-(66) are indefinite, and the sentences would be unacceptable with definite objects (e.g. **\*i muri si mame** 'There died his/her mother', **\*i ciga delegason ku no na pera ba** 'There arrived the delegation we were expecting', and so forth).

I will therefore assume that (62)-(66) do in fact reflect the most direct interfacing of semantics with syntax. That is, I will assume, rather standardly, that **ciga** or **muri** express a relation that involves only one entity, and this entity bears a role that can be variously described as Theme, Experiencer, etc. Corresponding to **i ciga un delegason** or **un delegason ciga**, we thus have the semantic representation (*ciga x*) where *x* is inside the predicate.<sup>33</sup> Direct interfacing will then yield:

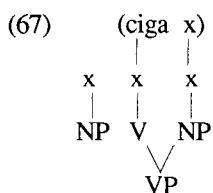

Again, the subject NP lexicalized as *i* is a purely syntactic object, hence an expletive. Linking *x* with the subject position provided by the syntax, on the other hand, results in the alternative construction **un delegason ciga**.<sup>34</sup>

That said, one cannot ignore the fact that such constructions as (62)-(66) belong to somewhat uncolloquial registers — they are extremely rare in folktales, but quite frequent on the radio — and find obvious parallels in Portuguese (*não sobra mais nada, avisamos o publico que chegou hoje uma delegação de Senegal*, and so forth). They may therefore be recent in the language, making all the more remarkable the extent to which they have been grammatically integrated.



## Chapter 7

### Middles, Passives, and Causatives

The constructions to be studied in this chapter have two things in common. First the argument patterns they realize deviate in some way from what may be considered the canonical realization of the arguments, viz. that where the subject of the verb denotes an actor, optimally human, who performs an action affecting the entity denoted by the object of the verb (on the semantic hierarchy involved here, see, e.g., Bresnan & Kanerva 1989; Siewierska 1991:6ff.). Secondly, they exhibit specific and sometimes complex interfacings of semantics and/or syntax with morphology. This latter property is well worth noting in a creole language, in view of the common opinion that creole languages have typically no or next to no morphology. If that is so, then Kriyol is not a typical creole language, as we shall see.

Middles and Passives will be studied together in the first section. We will then go over to causative constructions, of which there are two kinds in Kriyol: with an overt causative auxiliary, and with an incorporated causative operator.

#### 7.1. Middles and Passives

Consider the following example:

- (1) N ten di diskubri nunde ku esis miti nel. (FJDM)  
I have of discover where that these put in+it  
'I have to find out where these guys put themselves.'

**Miti** 'put, shove' is a transitive verb. In the normal state of affairs, there is a putter role attributed to the subject, a thing-put role attributed to the object, and a putting-place role attributed to a PP headed by **na** 'in' (e.g., **Ze miti cabi na gaveta** 'Joe put the key in the drawer'). In (1), however, we see that the syntactic subject of **miti** is also its semantic object. Yet, the form is not reflexive in spite of what a Portuguese translation might lead one to believe (*onde é que estes se meteram*). Inserting the Kriyol reflexive **si kabesa** 'one's head' (see Chapter 4) would result in absurdity, insofar as it would suggest that 'these guys' literally

carried themselves to a certain location. What we have in fact is a typical middle, meaning that the event initiated by the referent of the subject has this same entity as its main or only protagonist — with the usual implications of the person acting in his own behalf, or of the process closing in on itself, etc. In Portuguese, reflexive forms realize this meaning. In Kriyol, using a transitive verb intransitively may achieve the same result.

Although this process is not a productive one, in the sense that every transitive verb could be so used, it is by no means limited to *miti*. I will cite *maja* meaning ‘crush, run over’ (*i maja un pekadur ku si karu* ‘He run over someone with his car’) or ‘crash’ (*i maja na con* ‘He crashed on the ground’). There is also *fura* ‘pierce’ or ‘get a hole’ as in the following examples:

- 2) Donba Masi fura na tetu. (MSDM)  
 Donba Masi pierce in roof  
 ‘Donba Masi pierced his way onto the roof.’
- (3) I rebenta l baril na kabesa tok i fura. (MSDB)  
 he burst him barrel on head until it get-pierced  
 ‘He hit him on the head with a barrel until there was a hole in it.’

Similarly, *susa* can be used transitively meaning ‘soil’, or intransitively with a middle interpretation as in

- (4) Cakwal susa ku fora. (HGTD)  
 brief get-dirty with shit  
 ‘The briefs got dirty with shit.’

An inquiry specially addressed to this issue would undoubtedly uncover more cases of such transitivity alternations.

Of special interest are those verbs which are transitive in Portuguese but can only be used as middles in Kriyol. Here is an illustration:

- (5) Si bu oja kusa pirdi li, ka bu punta, i el. (MSLK)  
 if you see thing lose here NEG you ask it it  
 ‘If you see that something got lost here, don’t ask, that’s it.’

Portuguese *perder* means ‘lose’ and is used exactly like its English equivalent (*perdi uma coisa* ‘I lost something’). Kriyol *pirdi*, in contrast, can only be used as in (5), with the middle interpretation that Portuguese reserves for the reflexive form *perder-se* (*uma coisa perdeu-se* ‘something got lost’). For a transitive reading, one must have recourse to a causative formation (‘cause to get lost’), on which see below.<sup>1</sup> Meanwhile, there is something of a minimal pair in the contrast between, e.g., *turista pirdi* ‘the tourist lost himself’ (because he wandered away) and *turista pirdidu* ‘the tourist was lost’, that is he was wilfully waylaid by some malignant, if unspecified, agent. Which introduces us to the topic of passive constructions.

The basic properties of Kriyol Passives can be seen in the following example:

- (6) E purpara pa ba vinga se kunpanyerus ku matadu na  
 they prepare for go avenge their comrades who be-killed in  
 Manden. (MK)  
 Manding  
 'They prepared to go and avenge their comrades who had been  
 killed in the Manding.'

Passive is an entirely productive formation affecting all transitive verbs and materialized as a /-du/ suffix, as shown in (6) (*mata* 'kill', *matadu* 'be killed'). This morpheme is obviously descended from the Portuguese past participle suffix /-do/. Regularization has been thorough, however, so that there is no trace in Kriyol of the so-called 'irregular' forms such as *escrito* 'written' (Kriyol *skirbidu* 'be written'), *feito* 'done' (Kriyol *fasidu* 'be done'), and so forth. Moreover, despite this historical origin, there is no more justification here than elsewhere in assuming any kind of 'zero copula'. In terms of VP structure, Kriyol passive verbs behave just like their active counterparts, being interpreted as perfective when bare (see (6)) and being modified by the same tense and aspect auxiliaries. Witness the following example (compare with (66) in the preceding chapter):

- (7) I na bin dadu karton di konvidya a tudu artistas ku  
 it A and-then be-given carton of invitation to all artists who  
 toma parti. (RB)  
 take part  
 'Cartons of invitation will be given to all participating artists.'

Passive verbs may even occur in positions where they must obviously be analysed as non-finite, as in

- (8) Gosi nbe di faladu 'darnako' i ta faladu 'sapatu'. (I)  
 now instead of be-said 'darnako' it A be-said 'sapatu'  
 'Now, instead of saying [lit. being said] *darnako*, they say [lit. it is  
 said] *sapatu* ('shoe').'

Hence, passivization is correctly analysed, I think, as a lexical process in Kriyol. That is to say, passive verbs are autonomous lexemes connected to their active counterparts by rules of lexical correspondence (see Pollard and Sag 1987 for technical details). Alternatively, /-du/ could be considered a verbal lexeme morphologically characterized as an affix (or a clitic) and semantically defined as *PASSIVE* (which would suffice to guarantee that it affixes only to transitive verbs). I have no real preference for one solution over the other.

As evidenced by all examples so far, Kriyol passive is an agentless passive. The agent, i.e. the entity responsible for the event denoted by the verb ('kill', 'give', etc.) is left unexpressed, either because it is unknown — which may be the



case in (6) for instance — or because the speaker does not consider it useful or relevant to mention it, as in (7). Whenever the agent is known and worthy of mention, on the other hand, basilectal Kriyol will opt for the active. Passive constructions with a ‘by-phrase’ demoting the expressed agent to the status of an adjunct, as in the example below, definitely belong to decreolized, Portuguese-influenced registers:

- (9) Kil asasinus yera ba komandadu pa un branku. (RB)  
 that murderers be+PAST PAST commanded by a white  
 ‘Those murderers were commanded by a white man.’

We have here a slavish translation from the Portuguese *aqueles assassinos eram comandados por um branco*. But even the less lusitanized rendition **kil asasinus komandadu pa un branku** would still be anomalous in ‘deep’ Kriyol, which would only accept **kil asasinus komandadu**, presumably meaning that the said murderers were commanded to do whatever they did by some occult agency. Given that the agent is normally lacking, what will be the ‘surviving’ argument? In this respect, (6) represents the standard pattern. For clarity’s sake, let us simplify it to **se konpanyerus matadu na Manden** ‘their comrades were killed in the Manding’. The subject of the passive verb would be the direct, affected object of the active counterpart glossable as **un algin mata se konpanyerus na Manden** ‘somebody killed their comrades in the Manding’. The following interfacing of syntax and semantics will thus account straightforwardly for this configuration:

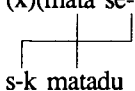
- (10) (x)(mata se-konpanyerus) SEMANTICS  
 SYNTAX

In (10), *x* is a variable that isn’t identified by any nominal constant. Therefore, it cannot be lexicalized, and the semantic inner argument is converted into a syntactic subject. Correlatively, the verb is lexicalized in the passive form, as a morphological flagging of the interface alignment whereby a syntactic subject links with a semantic object.<sup>2</sup>

I called (6) ‘standard’ because promoting (in the sense of Relational Grammar) an object to the status of a subject is certainly the commonest kind of passivization. Many languages, including Portuguese, accept no other form. Kriyol, however, ignores this limitation. There is first the case of double object verbs meaning ‘give’, ‘lend’, etc. Here, Kriyol is very much like English — and very much unlike Portuguese — since both objects may be promoted to subjecthood, with a distinct preference for the indirect object:

- (11) Dinyeru pistadu el. (I)  
 money be-lent him  
 'Money was lent to him.'
- (12) I pistadu dinyeru. (I)  
 he be-lent money  
 'He was lent money.'

The first version is all right, but (12) is by far the commonest.<sup>3</sup> Note how (11) shows the intransitiveness of passive verbs: in spite of its position, the third person pronoun is not assigned a case by **pistadu**; hence it must appear as the detached form **el**, with presumably inherent case, and the accusative (**\*dinyeru pistadu I**) would be utterly ungrammatical.

In (12), the indirect object may be considered a Goal in terms of semantic roles. Beneficiaries and maleficiaries can also be promoted:

- (13) Bajudas fididu jinjirba tudu i kaba, e say. (MM)  
 girls be-cut gums all it end they go-out  
 'All the girls had their gums tattooed, and then they left.'
- (14) Nyu Pucpac ka sta kontenti pabya i furtadu si galinya. (MSLK)  
 Mr. Pucpac NEG be happy because he be-stolen his chicken  
 'Mr. Pucpac is unhappy because he had a chicken stolen from him.'

Here, the active counterparts would be **e fidi bajudas jinjirba** 'They tattooed the girls' gums' and **e furta nyu Pucpac si galinya** 'They stole Mr. Pucpac's chicken'.

Finally, even 'deep' adjuncts can appear as subjects of passive verbs:

- (15) Kil banadera pudu mesinyu. (K)  
 that fan be-put poison  
 'Poison was put on that fan (literally \*That fan was put poison on).'
- (16) Ke ku kil dinyeru ta fasidu kel. (I)  
 what that that money A be-done with+it  
 'What is done with that money?'

In (16), the active counterpart of which may be reconstructed as **ke ku e ta fasi ku kil dinyeru** 'What do they do with that money?', only the NP has been promoted, 'leaving behind' a preposition which must therefore be followed by a resumptive pronoun (see Chapter 6 on questions). But the preposition can be simply dropped as shown by (15), the active equivalent of which would have to be **e puy mesinyu na kil banadera** 'They put poison on that fan' (and see the ungrammatical English quasi literal translation).<sup>4</sup> Of course, promoting the direct object always remains an open possibility (**mesinyu pudu na kil banadera, ke ku ta fasidu ku kil dinyeru?**). Again, however, there seems to be a preference, perhaps less marked than in (11)-(14), for promoting the most oblique argument. It is not clear what status such a 'rule' might enjoy, but its effectiveness in Kriyol

(or, albeit to a lesser extent, in English) cannot be denied. It will determine what semantic argument is linked to the syntactic subject position in interface (10), which continues to account for all cases.

The freedom of Kriyol passivization is further demonstrated by an example like the following:

- (17) Un dia nyu Kornobif manda comadu. (HGCS)  
 one day Mr. Corned-Beef cause be-called  
 'One day, they had Mr. Corned-Beef called.'

What is interesting in (17), a syntactic causative construction (see below), is that only the main verb, not the causative auxiliary, is in the passive form, contrary to what would be the case in English if such a construction was admissible in that language (?'Mr. Corned-Beef was made to be called'). Kriyol, in contrast, excludes such 'passive spreading' (\*nyu Kornobif mandadu comadu). A possible explanation, to which I shall return in the next section, is that **manda coma** 'cause to call' (**un dia e manda coma nyu Kornobif** 'One day, they had Mr. Corned-Beef called' — compare Portuguese *um dia mandaram chamar o Sr. Cornebife*) should be reanalysed as one predicate head, a complex verb, at least in the dimension pertinent for passivization. Hence the complex passive verb **manda comadu**.<sup>5</sup>

The conclusion to be drawn from the preceding evidence, then, is that all inner arguments of a transitive or ditransitive verb, including adjuncts, can be selected as the subject of the corresponding passive. Which one is chosen in a given case depends primarily on what can be described as an Obliqueness Hierarchy whereby more oblique arguments come first as preferred subjects — an antithesis to the Accessibility Hierarchy, as it were. Why this should be so, I just don't know. In any event, passive is quite an ordinary phenomenon in Kriyol. It is used every time a speaker wants to emphasize the fact that s/he has no inkling of the identity of the agent of the event s/he is reporting, or that identity is irrelevant.

## 7.2. Causatives

Kriyol includes both syntactic causative constructions (CCs) and morphologically derived causative verbs (CVs), as illustrated below:

- (18) Mame manda mininus say di kasa. (I)  
 mother make children go-out of house  
 'The mother made the children go out of the house.'
- (19) I fasi kusas ku ta puy I sufri un kastigu duru. (RB)  
 s/he do things that ASP make him/her suffer a penalty hard  
 'He did things that cause him to suffer a hard penalty.'

- (20) E bibinti omi binyu tok i ka pudi firma diritu. (K)  
 they drink+CAUSE man wine until he NEG can stand straight  
 'They made the man drink wine until he couldn't stand on his feet.'

The distinction between CVs and CCs lies in that (a) CCs are fully productive, whereas CVs are lexically limited; (b) while CVs imply some direct, physical action of the causer on the causee, CCs rather imply indirect causation through speech or circumstances as in (19).<sup>6</sup> I will now study them in turn, beginning by CCs.

### 7.2.1. Causative constructions

As evidenced in (18) and (19) CCs make use of two causative auxiliaries, **manda** and **puy**. Both are also full verbs meaning respectively 'order, control, be the cause' and 'put'. They cannot be used interchangeably insofar as **puy** implies that the caused process took place, an implication not shared by **manda**. For instance, (18) does not say that the children did finally go out, merely that the mother had them go out. The expected sequel is indeed that they left the house; but that is only a pragmatic implicature that can be superseded, so that (18) could be meaningfully followed by **ma e nega** 'but they refused'. Perhaps one would want to say that **manda** in (18) actually keeps its full meaning of 'order' — after all, an order is not necessarily obeyed. Yet, 'order' is not a plausible meaning in the fixed expression **el ku manda S** 'that's why S' where **el** may refer to just anything. What I would rather say is that **manda**, as a causative auxiliary, and perhaps as a reflection of its primary meaning, implies nothing more than that an entity acts in such a way as to be the cause of an event — although it certainly is true that the said entity is normally a human being, and the acting is verbal. Whether the event ultimately follows as an effect of that causation will depend on pragmatic factors such as the nature of the causee, viz. whether it is an animate entity capable of independent volition, like children, or not. In the latter case (e.g., **i manda karu say** 'He had the car out') the interpretation is ordinarily that the expressed causer is not the ultimate causer; somebody else drove the car out. The character of the complement is also relevant. An infinitive as in (18) does not imply completion whereas a finite sentence does (see **el ku manda mininu say** 'that's why the child went out'). Another argument for viewing **manda** as an auxiliary in these constructions rather than a full verb is (17) where, because of the way the passive is realized, we had to conclude that **manda comadu** forms a single predicate.<sup>7</sup>

Syntactically, it is easy to show that **mininu** in (18) is the object of **manda** rather than the subject of **say**: replacing it by a pronoun will yield an Accusative form (**mame manda I say** 'the mother made him/her/it go out', not **\*mame**

**manda i say**).<sup>8</sup> The best syntactic representation for (18) and like sentences is then probably (21) which accounts straightforwardly for the fact that the object of **manda** is also the logical subject of the infinitive:<sup>9</sup>

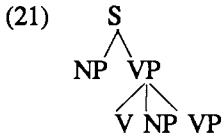

In turn, this tree is licensed by the following ID rule:

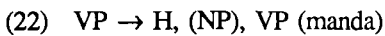

The NP is necessarily optional. Indeed, consider the syntactic structure of the active correspondent of (17), viz. **e manda coma nyu Kornobif** ‘they had Mr Corned-Beef be called’:

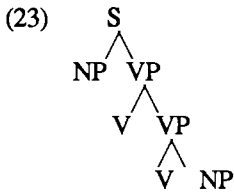

Here the NP-causee of (21) is syntactically absent (and it would appear in the semantics as an unidentified variable — see above). The lower NP is an object not only in the VP that immediately dominates it, but also in the higher VP. Given the characters of the Kriyol passive, the configuration is thus realized for this object NP to be ‘promoted’ to the status of subject of the complex VP [**manda coma**]. If the causee was lexicalized, in contrast, as in **e manda un algin coma nyu Kornobif** ‘they had somebody call Mr. Corned-Beef’, another possible active equivalent of (17), then passivization would be out, or it would yield an un-Kriyol (but otherwise acceptable) sentence, viz. **nyu Kornobif manda comadu pa un algin** ?‘Mr Corned-Beef was made called by somebody’.<sup>10</sup>

Needless to say, it is a contingent fact that the examples given here are all in the Perfective aspect. [**Manda V**] — similarly [**puy V**] — can of course be modified by an Aspect auxiliary (e.g. **mame na/ta manda minus say** ‘the mother is making/will make/makes the children go out’), with the same implicature — especially strong, it seems, with a Specific Imperfective interpreted as a progressive or a future — that perhaps the result won’t be achieved or is not always achieved.<sup>11</sup>

I want also to mention that, in terms of ‘extractability’, both possible argument positions under VP can be the origin of a UDC. Thus, starting from, e.g. **e manda**

**Jon coma nyu Kornobif**, one may construct either **kin ku e manda Jon coma** ‘who did they make John call?’, or **kin ku e manda coma nyu K.** ‘who did they make call Mr K.?’. Similarly with focalization: **nyu K. ku e manda Jon coma** ‘it’s Mr K. that they made John call’, **Jon ku e manda coma nyu K.** ‘it’s John that they made call Mr K.’. This ought to be contrasted with what happens when a clause (S[+COMP] or CP) boundary intervenes, for instance in **e manda pa Jon coma nyu K.** ‘they ordered that John calls Mr K.’ the corresponding question for which is **kin ku e manda pa i coma nyu K.** ‘who did they order that calls Mr K.?’. Extraction over the clause boundary is possible, but the extracted position cannot be the foot of a UDC to which a SLASH feature with a [+NULL] value is assigned; it must be a resumptive pronoun (see Chapter 6). This contrasted behaviour confirms that [manda (NP) VP] is indeed one VP.

In contrast with **manda**, **puy** does imply that the caused event took place, and it is used instead of the former every time the speaker wishes or is led to emphasize this fact. In (19), for instance, supposing that ‘he’ might not have suffered a harsh punishment after all would lead to a self-contradictory sentence. The effectiveness of causation, so to speak, can be underlined even more. Consider the following example:

- (24) I ka anos ku puy u bu pirdi kurida. (FJGK)  
 it NEG we that make you you lose race  
 ‘It wasn’t us who made you lose the race.’

It differs from (19) in that **puy**, instead of selecting a non finite VP like **manda**, is here followed by a finite clause. The associated semantic difference, according to my informants, is that (24) makes it crystal clear beyond any possibility of discussion that the person in question lost the race. (Perhaps a closer translation would be ‘It wasn’t us who acted so that you lost the race.’.) Not that (19) leaves a doubt; but (24) is still more insistent.

A disjunctive lexical ID rule must therefore be posited for **puy**:

- (25) VP → H, NP, VP ∨ S[-COMP] (puy)

The clause following **puy** may not include a complementizer. Another difference between **puy** and **manda** is also consigned in (25), viz. that **puy** must govern a nominal object. That is to say, while **i ka anos ku puy u pirdi kurida** is perfect, both **\*i ka anos ku puy bu pirdi kurida** and **\*i ka anos ku puy pirdi kurida** (to express ‘it wasn’t us who made (X) lose the race’ — OK **i ka anos ku manda pirdi kurida**) are ungrammatical.

When the second option of (25) is realized, an interesting constraint shows up, namely that the subject of the subcategorized clause must be a pronoun coreferential with whatever appears as the object of the causative auxiliary. In (24),

both object and subject are pronouns, so the constraint cannot be evidenced. But suppose the object pronoun is replaced by a noun, e.g. **Ze** 'Joe'. What we find then is that, while **i ka anos ku puy Ze i pirdi kurida** is all right, **\*i ka anos ku puy I Ze pirdi kurida**, with the reversed order for pronoun and noun, is unacceptable.<sup>12</sup> Why is that so? We may see here an instance of Principle C of the Binding Theory at work, since **Ze**, a referential expression, would obviously be bound by the preceding pronoun in the starred version. There is no problem, on the other hand, with the pronoun being bound by a noun in a separate clause in the acceptable version.

Although there is certainly much truth in that line of explanation, there is one thing it does not tell us, viz. why should the noun and the pronoun be coreferential to begin with. That is to say, why can't **i ka anos ku puy Ze i pirdi kurida** mean that we are not the ones who acted on **Ze** so that some other person, designated by **i**, would lose the race? Of course, the reason is the very meaning of the sentence, which is to say that, semantically, **Ze** and **i** are actually one argument and cannot be but one argument.<sup>13</sup> As for the hypothetical alternative interpretation, it seems it can either be construed as a double causative (**i ka anos ku puy Ze i puy Jon pirdi kurida** 'it wasn't us who made Joe make John lose the race'), or it cannot be expressed as a causative at all — probably as a consequence of the way we, as humans, not merely as Kriyol speakers, understand causation.

Another observation worth making is that, while **manda** has a clear equivalent in Portuguese (*mandar*), **puy** hasn't. Indeed, *pôr* 'put' cannot be used as a causative auxiliary.<sup>14</sup> On the other hand, **puy**'s meaning, especially the achievement implication it carries, makes it close to the other Portuguese causative auxiliary, viz. *fazer*, as in a possible translation of (24): *não fomos nós quem te fez perder a corrida*. Syntactically, however, **puy** seems closer to *mandar*. The reason for this is that *fazer* can only select an uninflected infinitive as in the example just given; *mandar*, on the contrary, selects either an inflected or an uninflected infinitive, depending on the position of the argument of the [*mandar* VP] complex. We thus find, besides *a mãe mandou sair os meninos* (see (18)) with an obligatorily uninflected infinitive, *a mãe mandou os meninos sair(em)*, with an optionally inflected infinitive. In both constructions, *meninos* is an object (compare *a mãe mandou-os sair(em)* 'the mother made them go out'). Considering the inflected infinitive to be an infinitive with an incorporated subject, one is thus led to see a syntactic parallel between (24) and the Portuguese inflected infinitive construction. The difference between both utterances is then simply that the subject of the lower VP is morphologically incorporated in Portuguese, whereas it is realized as a clitic pronoun in Kriyol, in accordance with

the general drift from one language to the other. **Manda**, in contrast, which must be followed by a (necessarily subjectless) non finite verb, behaves more like *fazer*, as suggested.

That said, the major parallelism between Portuguese and Kriyol remains that both *mandar* and **manda** denote a causation which does not necessarily go through and whose effectuation is primarily through indirect means such as speech; *fazer* and **puy**, in contrast, denote a more direct type of causation, one that is presupposed to achieve its effect. One correlate of this difference is that *mandar/manda* ordinarily take human agents as subjects, whereas *fazer/puy* do not share that limitation, as shown by (19). Direct causation and a preference for human agents are not incompatible, however, as we will see directly.

### 7.2.2. Causative verbs

Causative derivation, which seems to be no longer productive, proceeds by way of a [-nt/dV] suffix, where V is identical with the last vowel of the base, and the coronal consonant is voiced if the onset of the last syllable of the base is unvoiced; it is unvoiced otherwise. Despite (20), CVs derived from transitives are not the normal case. Only three have been spotted in a (not exhaustive but possibly nearly so) list of 40, viz. **bibinti** ‘make drink’, **kumente** ‘make eat’, **karganta** ‘load [X with Y]’.

The historical origin of the causative suffixation is worthy of some discussion. Obviously, Portuguese never had anything like morphological causatives. It includes a few verbs, however, that rather look as if they might be that, viz. verbs derived from the old present participle such as *aferventar* ‘boil (transitive)’, *amamentar* ‘suckle’, etc. Thus, one may contrast *aferventei a água* ‘I boiled the water’ (also expressible as *fiz ferver a água*) with *a água ferveu* ‘the water boiled’. (Compare Kriyol **n firbinti yagu** vs. **yagu firbi**.) Apparently, Kriyol generalized this derivative process, although not completely. Now, as I argued elsewhere (see, e.g., Kihm 1989), I do not think such generalization would have taken place were it not for the fact that a number of languages surrounding Kriyol include causative verbs whose morphological appearance happens to be surprisingly similar to that of Kriyol CVs. Compare, for instance, such pairs as Mandinka *fáa* ‘be full’ – *fandi* ‘fill’, *bèng* ‘meet’ — *bendi* ‘bring together’, *dómori* ‘eat’ — *dómorindi* ‘feed’ with Kriyol **inci** – **incindi**, **kontra** – **kontranda**, **kume** – **kumente** (see Rowlands 1959:104). Manjaku also has a causative suffix /-and/ or /-andan/ (see Buis 1990:46-47). Such chance encounters and the triggering effect they have on creolization constitute what I called ‘lexical conflation’ in the work cited.



As evidenced by (20), Kriyol is an ‘intermediate’ (Marantz 1984) or Rule 2 (Baker 1988) language: the would-be Agent of the transitive base (e.g. **omi bibi binyu** ‘The man drank wine’) is the direct object (DO) of the derived causative, while the would-be Patient appears in second object (O2) position (see Pollard & Sag 1987 for the definition of the grammatical relations). Other CVs are all derived from intransitive bases, mostly unaccusative (29 out of 40), with a few unergatives (8 out of 40). Examples of the former category are **firbinti (yagu)** ‘boil (the water)’ (**yagu firbi** ‘the water boiled’), **pirdinti (cabi)** ‘lose (the key)’ (**cabi pirdi** ‘the key got lost’); of the latter, **durminti** ‘put to sleep’, **mamanta (mininu)** ‘suckle (a child)’ (**mininu na mama** ‘The child is suckling’).

The questions to be answered are therefore: (a) How should sentences involving CVs be represented? (b) Why are Kriyol CVs mostly derived from unaccusative bases, and are the few non unaccusatives endowed with specific characters?<sup>15</sup>

#### 7.2.2.1. The representation of CVs

In Marantz’s theory of causatives (1984), Kriyol CVs would be considered monoclausal. That is, the merger of the CAUSE functor and the verb occurs at the lexico-semantic (l-s) level, rather than at the syntactic (s) level, giving rise to representations like the following :

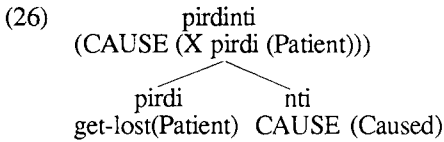

In (26), it is criterial, of course, that **pirdi** should be interpreted unaccusatively, that is with its syntactic subject actually a Patient.<sup>16</sup> In Baker’s theory (1988), the same result would be achieved by applying Move-alpha to the verb and raising it to the CAUSE operator that governs it at D-structure. Here, however, I will attempt an Autolexical account, which is indeed more germane to Marantz’s view than to Baker’s, insofar as the former is representative rather than derivative. Although it isn’t my primary goal, I hope the following argument will demonstrate that such an account leads us to a fuller and sparser explanation of the evidence than do the other two.

The crucial hypothesis for the AS treatment of CVs like **pirdinti** is that the dimension where it makes sense to posit a CAUSE operator is the semantic one. In Sadock’s words, “The semantic component should provide representations of natural language expressions in terms of the logical relations that obtain among the meanings of the formal elements that make up the expressions” (1991a:23). The

semantic dimension of AS is thus close to Marantz's 1-s level, in that it includes representations of function-argument and variable-binder relations which in GB theory are apportioned between D-structure and LF. The relation between CAUSE and a verb is an instance of operator-function relation whereby an operator (CAUSE) is applied to a function (V or rather VP) and returns a new function. **Jon pirdinti si cabi** 'John lost his key' will therefore be given the following semantic tree representation:

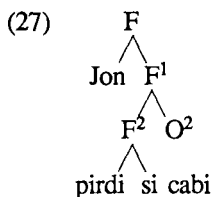

where F is a saturated formula, with all its arguments realized, F<sup>1</sup> is a formula lacking one argument (the subject), and so forth; O<sup>2</sup> is the transitive operator CAUSE taking a formula as its argument. A point to be emphasized again is that linear order is not relevant in semantic representations. The order shown in (4), with O<sup>2</sup> immediately following the formula it modifies, is purely a matter of convenience. What is significant is that the operator should govern the elements on which it bears, and that it does in (27) no matter whether it appears on the right or the left of F<sup>2</sup>.<sup>17</sup>

As far as syntax goes, then, there is nothing special to be said about **Jon pirdinti si cabi**, the syntactic structure of which can be kept quite surfacy:

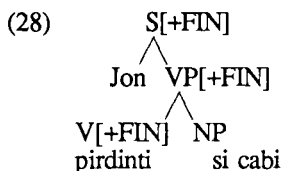

The interesting comparison is between semantics and morphology. Indeed, what stands in need of an explanation is the fact that CAUSE, an autonomous element of meaning, is ultimately realized as a bound morpheme.<sup>18</sup>

As already noted, GB practice here, as developed in Baker (1988), is to have the syntax take care of the "merger" of the operator and the verb (through Move-alpha), and then leave it to the phonological component (PF) to fix the final shape of the derived element. What this procedure leaves unaccounted for is the fact that the meaning element CAUSE ends up being matched with a suffix rather than something else. Since morphology does not constitute a proper component, no

generalizations can be formulated at this level in connexion with other levels. Neither will the lexical-conceptual structure (LCS) help, as the entries that make it up are not supposed to include details of the inner constituency of lexical items. Interfacing semantics with an autonomous dimension of morphology solves these issues. Consider (29):

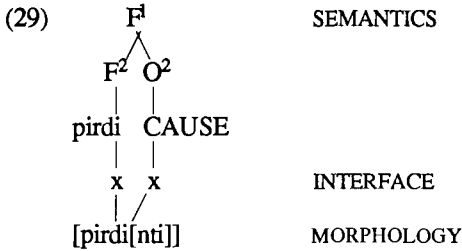

In order to account for the fact that the matching is of (pirdi(CAUSE)) — or equivalently ((CAUSE)pirdi) — with [pirdi[nti]] rather than, e.g., \*[[nti]pirdi], all we have to do to begin with is to state the following morphological Linear Precedence (LP) statement:

(30) Word: X < H

meaning that, within a word, everything precedes a head (H). Put differently, Kriyol complex words are right-headed, as readily demonstrated by such derived nouns as **camidur** ‘drunkard’ from **cami** ‘drink (spirits)’, **amigundadi** ‘friendship’ from **amigu** ‘friend’, etc. (see chapter 4). But why is [nti] the head in **pirdinti**? Morphosemantic interfacing gives a principled answer: because it is matched with the meaning element CAUSE which is itself, by definition, the head (i.e. the modifying operator) of the formula (pirdi(CAUSE)). Hence the (partial) lexical entry for [-nt/dV] which recapitulates the informations pertaining to every dimension:

(31) [nt/dV] (Kriyol)  
 syntax: nil  
 morphology: [<sub>VO</sub> VO\_\_]  
 semantics: O<sup>2</sup>, CAUSE  
 NP1 CAUSE VP  
 NP1 = CAUSER  
 VP = CAUSED

The “nil” notation for syntax simply states the fact that [nt/dV] plays no role in this dimension. The morphology line says that [nt/dV] combines with a verb to form a verb. Marking it explicitly as a suffix would be redundant since that results from its head status, itself expressed on the semantic line, and the LP statement (30) which can be viewed as a well-formedness condition over Kriyol lexemes.

Let us now compare the lexical entries for **pirdi** 'get lost' and **pirdinti** 'lose':

- (32) **pirdi** (Kriyol)  
 syntax: V<sup>1</sup>  
 morphology: W  
 semantics: 'get lost'  
 NP1 **pirdi**  
 NP1: THING LOST
- (33) **pirdinti** (Kriyol)  
 syntax: V<sup>2</sup>  
 morphology: [<sub>w</sub> **pirdi** [<sub>w</sub> nti]]  
 semantics: 'cause to get lost'  
 NP1 **pirdinti** NP2  
 NP1: CAUSER OF LOSS  
 NP2: THING LOST

Whereas **pirdi** is a simplex, **pirdinti** is a complex word, so its morphology cross-references to (32) as well as to (31). The syntactic valency of **pirdinti**, a simple transitive verb, shows up equal to the semantic valency of its morphological head, [nti], a two-argument operator. This is the result of the morphosemantic interfacing described in (29). **Pirdi**, on the contrary, is intransitive. Finally, comparing the semantics of (32) and (33) makes two things apparent. First, both lexemes share a meaning, viz. "lose", however it should be analysed or paraphrased. Secondly, there is a systematic relationship between them in terms of the roles fulfilled by the arguments (see Pollard & Sag 1987 for this notion of role): the subject of **pirdi** corresponds to the object of **pirdinti**, and both encode the role of the lost entity. The difference is that **pirdinti** encloses a loser (causer of loss) role, whereas no such role is available with **pirdi**.

Which takes us directly to the unaccusativity issue. Before tackling that, however, I would like to briefly raise one related question.

It must be noted that (27) is an adequate semantic representation for CCs as well. Except that the relevant interface is then the semantico-syntactic one rather than the morphosemantic one, since the CAUSE operator is realized not as a morpheme, but as the auxiliary verb **puy** or **manda**. The difference and similarity of the two types of causatives are thus easily captured (see Sadock 1991a:170ff.). Of course, there remain the question of why cannot one say \***Jon puy cabi pirdi** 'John made the key get lost' as an alternative to **Jon pirdinti cabi**? I will try and answer that in the next subsection, since it is also linked to the unaccusativity issue.

### 7.2.2.2. *The unaccusativity issue*

The second, and ultimately most substantive question to be answered is then that of the inherent semantic characters of the verbal bases that appear to be preferably eligible for causativization. That is to say, why is it the case that a majority of CVs are associated with unaccusative bases? Is there something in unaccusativity that may be held responsible for this? Or is it rather some other factor of which unaccusativity is but a secondary, perhaps insignificant correlate?

As already mentioned, a constant implication of sentences pivoting around CVs is that a causer, typically but not necessarily animate, directly forces a causee to do something or to be in a certain state. If the causee is animate, generally a human or a humanized animal (as in tales), the implication is actually that s/he does not exert his/her own will, or is even resisting. For instance, (20) strongly suggests that drink was forced into the man's throat, not that he was talked or even threatened into drinking. With inanimate causees such as keys, of course, the question of will does not arise. It is remarkable, however, that at least two CVs, **firmanta** 'put in a standing position' and **ditanda** 'lay down', whose object-causees are typically things, further imply that the position achieved is somehow contrary to normal. One finds thus **firmanta libru** 'to stand a book on the side' or **ditanda garafu** 'to lay a bottle on the side', but one would not say **#firmanta un algin** instead of **puy un algin i firma** 'make someone stand up', unless it is the case that this someone is unable to stand up by him/herself (because of disease, death, etc.). CCs do not share this implication; as we saw, they rather imply the contrary, namely that the causee did something deliberately, be it at the causer's instigation, to bring about the event or the state. We have here an explanation, incidentally, of why **\*Jon puy cabi pirdi** isn't possible, since it would imply that the key somehow participated in its own loss.

There is clearly a correlation between this notion of a reluctant causee and the fact that the subjects of unaccusative verbs endure the process or state denoted rather than they make it be. It is interesting in this respect to note that verbs such as **ciga** 'arrive' or **kuri** 'run', whose status is somewhat uncertain from a semantic viewpoint, inasmuch as their subjects could be Agents as well as Patients/Themes,<sup>19</sup> are quite unambiguous when causativized: **ciganta** is only used with inanimate causees, and it actually means 'bring over' (**ciganta kadera!** 'Bring a chair over!'); similarly, **kurinti** really means 'drive' (**kurinti karu** 'drive a car'), and it cannot be used for, e.g., 'make a dog run' (**manda/puy kacur kuri**).

There seems therefore to be a reasonable possibility for proposing, if not a semantic definition, at least a semantic correlate of the primarily syntactic notion of unaccusativity. Note however that such a correlate — 'uncooperative subject'

might be an accurate enough denomination — is both wider in coverage and different in nature from the notion of ‘affected subject’ or ‘Patient/Theme subject’ that is standardly considered diagnostic of unaccusativity.<sup>20</sup>

Indeed, subject patienthood is an inherent feature of the thematic grids or relational networks attached to the verbs involved. True, there are borderline cases and some parochial variation (see, e.g. McClure, 1990), but a significant core of clear tokens seems to exist, whose subjects cannot but bear the Patient role in all known languages — ‘fall’ might be a good example. If this is true, it means that unaccusativity has to do with the very fabric of the event or state being denoted: if the subject of *fall* or its equivalent in any language were not somehow marked as being affected by the event rather than responsible for it, a Patient rather than an Agent, then *fall* would not mean ‘fall’.

The types of events or states whose subjects may be described as uncooperative under certain circumstances, however, are obviously much more numerous and varied. The doubt would rather seem to lie on the side of whether there may be events or states the subjects of which may never be thought of as unhelpful. This is clearly, I think, a matter for some kind of pragmatic semantics to decide, with probably a fair amount of intercultural variability. To such an extent, then, there is a sharp distinction between this notion and that of Patient subject which seems rather to belong to the domain of logical semantics.<sup>313</sup> As a consequence, they require different treatments, at least to some extent. Before we come to that, let me be a little more specific about the whole idea and how it helps us explain the observed distribution of CVs as opposed to CCs.<sup>22</sup>

To repeat, three things stand in need of an account: (i) the prevalence of unaccusative intransitive bases; (ii) the rarity of transitive bases; (iii) the special characters, if any, of the few remaining intransitive bases.

As for (i), I would repeat in a slightly different form what was already pointed out above: there is a natural affinity between a subject’s patienthood and absence of volition on the part of the same. Unaccusativity is not the determining factor, however. Rather, once morphological causativization bears the implication that the subject-causee does not cooperate in the state of affairs being brought about, it is only natural that those verbs will predominantly be causativized which already include the information that their subjects are Patients rather than Agents. Conversely, one is led to conclude that, if there are (at least in Kriyol) verbs denoting states of affairs such that their subjects could not but be considered responsible for them in all configurations, such verbs should not be eligible for causativization.

This might be the explanation for the paucity of CVs derived from transitive bases. One may reasonably hypothesize that the subject of a transitive verb (bearing the Ergative case in languages where such exists) must be construed as an Agent, and that only very special circumstances will allow one to view it otherwise. Force-feeding is conceivable, but how would you force someone to write a letter entirely against his/her will? Or to buy a pound of tomatoes? Or to hammer a nail? And so on and so forth. Recall that direct physical action on a causee that, if animate, acts under total coercion, *perinde ac cadaver*, is what Kriyol CVs imply. Here, a semantic theory of prototypical situations, perhaps along the lines of Barwise & Perry (1983), would be a great help.<sup>23</sup> A correlate of this view is that, where transitive-derived causatives are common, morphological causativization should not include the uncooperativeness implication. This should be easy to check.<sup>24</sup>

Finally, the few unergative verbs that causativize all clearly denote events such that their subjects may conceivably remain passive while they are being achieved. **Mamanta** 'suckle' is a ready example. But so is **yandanta** 'make walk' considering that it is only used with an object-causee of which it is understood that it couldn't walk by itself (a child, a sick man, etc.), or **buanta** 'make fly', used with objects such as kites, and so forth. I already mentioned **kurinti** where the "running" entity has to be a vehicle.

The question then is how to represent such a completely semantic constraint in the most natural and cognitively plausible way. Theories such as GB whose semantic component, to the extent that they have one, can only treat argument structure and operator-variable relations, are unable to deal with a phenomenon of this kind in an integrated fashion. Of course, it won't appear as a weakness of the theory if it has been ruled in advance that notions like "uncooperative subject" do not pertain to grammar proper, but to some ill-defined, non linguistic mental dimension for which the catch-all label "knowledge of the world" is often deemed sufficient. Given that this notion has clear grammatical correlates, however, an integrated treatment would nevertheless seem to be desirable and to constitute a definite superiority of the theory that makes it available.

The task then is to add another semantic dimension to the model, one where common knowledge of conceivable situations can be represented, and to interface it with other relevant dimensions. A formal tool often used to express that sort of thing are Meaning Postulates (MPs) of the form 'If X, then necessarily or possibly Y'.<sup>25</sup> No claim of psychological reality attaches to MPs as such. They should be considered convenient notations of subliminal (preconscious) pieces of knowledge that non deficient speaking (thinking) subjects must be supposed to possess and to have tacitly recourse to when expressing themselves — for instance, that a living

being can be forced to eat or to drink totally against its will, whereas hammering a nail, even with a gun at one's back, necessarily requires exercising some personal will. The following MP would be pertinent for our problem:

(34) MP: If NP VPs, then NP may not cooperate to VP

Let us assume that (34), along with all other MPs we might need, constitute a specific dimension that we may call 'Situational Knowledge' (SK). As already mentioned, whether a given MP, say (34), will be activated depends primarily on the lexical meaning of the verb heading the VP. Even though we may not suppose that the lexical entry contains that kind of knowledge, it remains within the bounds of reason to assume that it includes a flag (e.g. 'see MP *n*') referring to one or several MPs. This amounts to nothing more than claiming that words cannot be used meaningfully if they are not taken in a network of informations that are not normally evoked, but may be.<sup>26</sup> The flag is thus the formal means through which SK is interfaced with other dimensions. Verbs like 'fall' or 'eat' will bear it; 'hammer', 'buy', 'swim', etc. won't. Only verbs bearing it are able to causativize.

Of itself, (34) doesn't pull through. It is merely a general admonition to the effect that subjects, even when their predicates belong to types compatible with Agents, may not be responsible for the event denoted by the predicate. It helps understand or produce such sentences as 'The stone hit the man', which would sound absurd otherwise, but it does not suffice for the precise semantics of Kriyol CVs. What we need is a notion of MPs functioning in networks rather than in isolation, i.e. harking back to each other to build more and more complex pieces of situational knowledge. (In that sense, SK is a dimension, not a collection of 'situationalia'.) Let us then try and piece together a possible network for (34).

In order to fully link (34) to causativity, we need the following MP or its equivalent if better formulations can be devised, as I have no doubt they can:

(35) MP: If NP1 causes NP2 to VP, then NP2 VPs

MP (35) is invoked with all causative expressions, no matter whether the causee is seen as cooperating or not. It simply says that, if I made John drink the wine, then John drank the wine, voluntarily or not, and I couldn't meaningfully utter 'I made John drink the wine' otherwise. In English, 'cause', 'make', and 'have' (at least) would be flagged for it. In Kriyol, causative *puy* (which I assume to be distinct from *puy* meaning 'put') bears this flag. By way of illustration, here is a possible lexical entry for *puy* 'cause, make' :

(36) *puy* (Kriyol)  
 syntax: [<sub>S</sub> NP<sub>i</sub> – NP<sub>i</sub> [<sub>S/VP</sub> (Pro<sub>i</sub>) VP]]  
 semantics: cause, MP 35



Note that *puy* is not flagged for (34). Now take *Jon pirdinti si cabi* ‘John lost his key’ again. *Pirdi* ‘get lost’ is an unaccusative verb, so that (34) is automatically invoked. With entities such as keys, the question of will does not arise. But persons can get lost too, and as a consequence they can be lost against their will, so that *Jon pirdinti turista* is a meaningful sentence signifying that John lost the tourist, i.e. acted in such a way that s/he got lost (typically with malice aforethought).

Being a CV, *pirdinti* is flagged for (35). There is now an important technical detail to be considered. Indeed, we might assume that, since it is the suffix [nt/dV] that carries the meaning ‘cause’, it is it that is flagged for (35). As a result, *pirdinti* would be flagged for both (34), like its base, and (35), like the suffix. But that is clearly wrong since it implies that *pirdinti* could itself be causativized, deriving \**pirdintindi* ‘cause to cause to get lost’. Such a form is excluded, for the sufficient reason that he or she who makes some entity act in a certain way cannot do so in a totally uncooperative way. That is to say, in *Jon pirdinti si cabi/turista*, the key or the tourist did nothing to get lost, but John did do something. CVs thus align themselves with the huge majority of transitive verbs, whose subject must be conceived of as cooperating to the event. Therefore, the only way to express, e.g., ‘They made John lose the tourist’ is with a CC: *e puy Jon i pirdinti turista*.<sup>27</sup> (Recall that *puy* does not evoke (34).)

It is crucial, then, that MP flagging should be at the level of whole lexemes. Put differently, whereas only verbs evoking (34) have corresponding CVs in Kriyol, CVs themselves do not evoke (34), but only (35). As a result, *Jon pirdinti si cabi* can be given all the meanings we know it to have, namely (a) that the key did get lost, (b) that it did nothing to be in such a state, and (c) that John did something definite (albeit unvoluntarily) to put it into that state. Meaning (a) is provided by (35) as evoked by *pirdinti*; meaning (b) results from *X pirdi* ‘X got lost’ being part of the semantic representation of *Y pirdinti X* ‘Y lost X’, and *pirdi* evoking (34); meaning (c) is a default inference for all verbs not flagged for (34). Similarly, we understand *e bibinti omi binyu* to mean that the man really drank the wine, that he did not cooperate in the action (hence was physically forced to it), and that ‘they’ did something (e.g. put a funnel into his mouth) to achieve this result. In terms of the architecture of the model, all this is obtained by interfacing SK with (29) through the flag in the relevant lexical matrix.

Allowing for some socio-cultural variation, MPs, or rather the situational knowledge they translate, may reasonably be supposed to be universal. What may be language-specific is their invoking. In particular, there is no obligation for an MP like (34) to be invoked at all. Of course, not invoking (34) does not imply that the speakers of a given language view falling people as cooperating to their fall,

or are not aware of the possibility of forced feeding. It simply means that this knowledge plays no specific role in the grammar of their language. For instance, in languages that have but morphological causatives, the cooperativeness of the causee may not be an issue at all, and CVs will fulfill all the functions that are apportioned between CVs and CCs in Kriyol. Not to leave the area, such might be the case of a number of, if not all languages surrounding Kriyol (Mandinka, Manjaku, Balanta, etc. — but remember the two causatives of Wolof mentioned in fn. 24). Conversely, languages with exclusively syntactic causatives (of course abstracting non derived causatives such as ‘boil’ in ‘boil the water’, to say nothing of ‘kill’), such as Portuguese, will be inclined to ignore the issue as well.



## Chapter 8

### Beyond the sentence: a few considerations on Kriyol texts, especially comic-books

Ideally this chapter should be devoted to such matters as phraseology, pragmatics, enunciatory conditions, and so forth. Alas, my expertise here turns out to be even more limited than elsewhere. Besides, I made appeal to semantic and pragmatic factors in the preceding developments frequently enough that the little I would specifically be able to say on these subjects would add practically nothing. In fact, what I intend to do here is to pay tribute. Of the examples I used as a (hopefully) representative sample of the language, a few are made up, many are recorded live utterances, but a majority are taken from what I will not hesitate to call literary texts, namely comic-books. Are those texts really reliable sources? What are they, and how and by whom were they produced in the first place? In order to answer these questions, I will attempt a short history and analysis of Kriyol comic-book stories, trying to show that not only are they an extremely reliable source of information on the language, but they constitute a fascinating literary phenomenon in their own right. Moreover, the fact that they appeared in the context of an almost exclusively oral linguistic market (in the sense of Bourdieu 1982) makes them especially significant for the evolution of the language.

The first booklets came out at the beginning of the 80s, probably in 1983 (see Pinto-Bull 1989:121ff.). Production was in full swing all through the decade. It may now be declining for reasons I will try to assess later. The usual format is a 15x21cm booklet of 20 to 30 pages, photocopied. Distribution is either informal, from hand to hand, or the issues are sold on the markets, especially the *feira de Bandim*, the biggest market in Bissau, where I could buy a few.

The authors may adequately be described as autodidacts insofar as none of them, as far as I know, studied drawing in Institutes of Fine Arts or similar places before starting their activity. Some went abroad, for example to Brazil, in order to

improve their technique (needlessly, I think), but only after their work had been noticed and had imparted a certain notoriety to them, so they could secure scholarships. This does not mean they were not exposed to influences, however. The cultural significance of comic-books is something that may require some explaining, especially to American readers with a PhD for whom they generally evoke the rather illiterate, although quite enjoyable, production of Superman, Batman, and other 'super-heroes'. (In my experience, only very cultured persons in this community preserve a knowledge of such pre-war masterpieces as Flash Gordon, Buck Rogers, Little Annie Fannie, etc.) Not so in Europe, especially on the continent, where comic-books (better designated by the French term of *bandes dessinées* or the Portuguese calque *bandas desenhadas* — BD for short) knew a remarkable artistic development after the Second World War, first in the works of the so-called 'Belgian school' featuring such names as Hergé, Edgar P. Jacobs, Franquin and others. In the 60s and 70s 'adult' comic-books began to appear — where 'adult' does not mean pornographic, but refers to the character of the stories being told, ones that adults may want to read just as they read 'serious' literature. France, Italy, and Belgium were the main centres of this movement. But it also reached Spain and Portugal, particularly after democracy was restored in these countries.<sup>1</sup>

What I want to suggest is that Bissau-Guinean comic-book artists were necessarily exposed to this production in spite of the relative cultural isolation of their country before and even after its independence. They were exposed to it through Portugal and also through the *Centre culturel français* which, throughout the 80s, had the only general public library in Bissau, with a well-assorted and much-perused collection of *bandes dessinées*. (No chauvinism should be suspected here.)

This exposure shows in their drawing style. It is certainly true to claim that realistic drawing has no tradition in West Africa. It would therefore be vain to look for African features in this domain, except perhaps in the stylized and angular drawing of some of Manuel Julio's stories, for instance *Punta pa sibi bon* 'Asking in order to know is a good thing'. On the other hand, Humberto Gonçalo betrays clear influences from the underground fanzines that blossomed in the wake of the 'cultural revolution' of the 70s. Especially in *Caleron di sorti* 'The Cauldron of Chance' and *Minjer i Venenu* 'Women are Poison', he reveals himself as a master of the purposefully 'dirty', pseudo-naive drawing. Fernando Julio, in his marvellously funny *Tris nkurbadus* 'The Three Hopeless Ones' series, seems rather to lean toward the Belgian school, with its preference for well-delineated contours. This influence can also be detected in Manuel Julio's Ntori Palan series.

Africa reigns supreme, in contrast, in the stories being told. A rapid analysis of two works will show it. In the *Tris nkurbadus* series just mentioned, it is the plot of the traditional West African folktale that is transposed (on the passage from oral to written literature, see i.a. Pilaszewicz 1985). The Three Hopeless Ones are called Ataya Ju, Bafatoryu, and Sapu Fora.<sup>2</sup> Ju being, it seems, a Manjaku personal name, **ataya**, obviously from Wolof *attaaya* 'tea' (itself from Arabic *aT-Taayu*), is a euphemism referring to cashew wine.<sup>3</sup> Bafatoryu, from **bafa** 'extinguish', designates those snacks of peppered fish in lemon sauce one eats while drinking wine or **kana** (unrefined rum). The two character's favoured activity is thus sufficiently outlined. Sapu Fora, on the other hand, literally means 'Toad Outside', and is the name one gives to uninvited guests who try to sneak into an occasion and partake of the fun and food. Ataya Ju and Bafatoryu are all the time organizing complicated set-ups with no other goal than finding something to eat (preferably cat or pork) and/or to drink. Sapu Fora's constant effort, on the other hand, is to frustrate them of the result of their scheming, by brute force or gross cunning. He usually fails. One will have recognized in the first two this eternal trickster of West African folktales, Rabbit (*Lebri* in the Kriyol versions), who they jointly incarnate; Sapu Fora, of course, is Hyena (*Lubu*), stupid and greedy. The narrative style is also very much that of folktales. Because the reactions of the characters and the plots themselves are by and large known in advance — and the listening or reading audience's pleasure is in renewed familiarity rather than in discovery — there is no need for those supposedly realistic or logical connections which articulate Western stories. The essential parts of a story are of course there: introduction, narrative, and conclusion. Events are never explained, however, they just happen. We shall never know why Sapu Fora decides to dress as a woman in order to trick Ataya Ju and Bafatoryu at the end of the episode called *Dokumentu Maximu* ('Maximum Document'). He does it after having munched cola nut during eight hours, and that's it. Notice that the device of enclosing the characters' thoughts in dotted balloons — thus allowing them to expose their intents — is seldom used. We are indeed in the universe of the folktale, not that of the classical novel. (European and North American comic-books are types of classical novels.)

Nyu Finadu, the hero of Humberto Gonçalo's *Caleron di sorti* and *Minjer i Venenu*, on the other hand, looks rather like a modernized version of the 'enfant terrible', another folktale stock character (see for instance the story of Sara and Demba in Montenegro & Morais 1979:45-52).<sup>4</sup> Entirely free of moral restraints, his inner state clearly depicted by an unabashed drawing, he proposes to beautiful Sardinia without unnecessary circumlocutions: 'I've got something very important to tell you. I don't think it should anger you. I want you to marry me. I've got a position' (he's a bush taxi driver). She, equally unembarrassed, answers, 'It's too

bad I'm already married. If you wish, I'll be your mistress. You may come today sleep with me in my house. My husband is a hunter. He's away hunting.' Manuel Julio's Ntori Palan and Humberto Gonçalo's Mingon Bicu are still clearer variations on the bad boy theme.

The bawdiness just alluded to is another regular feature anchoring comic-book stories in the West African pre-monotheistic tradition. It is not that Bissau-Guineans are somehow 'freer' or less 'repressed' than anybody else in those matters, it is simply that, as in all basically peasant societies (including pre-industrial Europe), sex and excretion are acceptable and preeminent objects of jokes. In this respect, among many others, Guinea-Bissau shows herself to be markedly different from her former associate Cape-Verde, where Portuguese official values seem to have penetrated much more deeply into the people's mentalities (see Meintel 1984). She is also different, although to a lesser extent, from her continental neighbours Senegal and Guinea-Conakry where Islam is more dominant. The fact that nearly all authors are Catholics (even though not 'good' Catholics), who rarely miss an occasion of making fun of the *murú* (the Muslim Manding or Fula), is of course crucial.

Yet, for all their traditionalism in terms of narrative style, comic-books stories are entirely modern in their intentions and the situations they depict. Satire is the overall purpose. What is satirized? A regular target is the petty civil servant, policeman or *fiscal* (a kind of excise officer), who abuses his power. But there is also the parvenu returning from Portugal loaded with shirts and dungarees he tries to sell at ten times their price; the ministry employee sleeping at his desk; the lecherous good-for-nothing living off women; the boastful soccer player who got himself kicked out of every Portuguese club; and so forth — a whole picture gallery exposing some of the human types a contemporary African society will produce in its transition from vanishing tradition to uncertain modernity.

This satirical dimension is what helps us understand, I think, why it is that our authors chose the comic-book as a medium to begin with. In fact there was no choice. Given the purpose and the context it had to be a modern medium anyhow. And of those, only two others would have been adequate, viz. the novel and the film. The latter was out for financial reasons.<sup>5</sup> As for the former, novels dealing with everyday life as comic-books do would have to be written in Kriyol as comic-books are. But this is where the language becomes an obstacle. Kriyol is still a predominantly oral language, marvellously fit for dialogue and rapid narration of bare events; it has not developed the stylistic tools necessary for complex descriptions of settings or inner states.<sup>6</sup> Furthermore, it could do so in the present state of affairs only by getting closer to literary Portuguese. That, however, would mean restricting the audience to learned people whose knowledge of literary Portuguese

would permit them to decipher the artificial idiom thus created. One may doubt they would have the patience and the interest for it.

Comic-book art, in contrast, offers the best of several worlds. It is modern; it is cheap, contrary to cinema; it accomodates the ordinary language, contrary to the novel. In comic-books as in films, language is important, but not all-important. It is my experience that literate adolescents and adults (i.e. literate in Portuguese, the only language of schooling) may have difficulties reading Kriyol texts. Not only because of the relative (and varying) exoticism of the spelling (see Introduction), but probably also for the deeper reason that they unconsciously refuse to associate Kriyol with writing. Nevertheless, the pictures allow them to follow the stories, so they get progressively used to recovering their everyday means of expression under this guise of a written text.

In turn, all the characters exposed so far — local rooting, modernity of the themes, relative dispensability of the text vis-à-vis the pictures — guarantee that the language used is indeed the genuine speech of everyday intercourse. The medium and the purpose conspire in giving the authors no motive for embellishing or sophisticating their language in any way. Writing as one speaks is probably an unattainable ideal, but we may say that our authors approach it as much as will ever be possible. Hence the unparalleled value of such works for language study. On the other hand, one should not infer from this ‘colloquial’ character of the texts that the authors pay no or little attention to language. On the contrary, their observation of linguistic mannerisms and fads — especially the use of Cape-Verdean or pseudo-Portuguese expressions — is often very accurate, thus adding to the documentary interest.

Bissau-Guinean comic-books constitute an exceptional literary phenomenon. Developing a literature in a hitherto exclusively oral language is always a shaky, and often a doomed enterprise, if only because there are no readers and no inherent necessity for telling that kind of stories in that language rather than in the dominant language. The difficulty is compounded when the language in question happens to be a creolized variety of the dominant language. Caribbean writers in French territories had that experience. The few that attempted to write in the Creole, such as the Martiniquese Raphaël Confiant (see, for instance, his excellent novel *Kod yanm* ‘The Yam Root’ published in 1986 by a local press), all reverted to French sooner or later. A French leavened by the Creole, but French all the same. Here, in contrast, the use of Kriyol rather than of Portuguese (or of any of the local, equally unwritten languages for that matter) was so to speak forced. No other means of expression would have made sense given the topics dealt with.



Correlatively, Kriyol could be put into writing with a minimum of distortions, and readers were secured, no matter what difficulties they may have had deciphering the texts. The pleasure it gave them was a sufficient incentive.

I cast the last few sentences in the past, because I am not at all sure that comic-book production is still going on as I am writing this (December 1992), let alone that it will continue in the future — at least under the same form. There would be several reasons for their disappearance, economical as well as cultural. The main one, as far as I am aware, is that Guinea-Bissau, like the whole world, is inexorably moving into the Western cultural orbit. This is probably not to be deplored, especially because this world-wide movement will ultimately rock the West out of its orbit. Meanwhile, one can rightly fear that people in Guinea-Bissau will finally assimilate a few mainstream Western truths, for example that comic-books not industrially produced are uninteresting (better watch Brazilian soap operas), and that it is not dignified to make jokes out of people having sex or shitting in their pants (people cut to pieces are all right).

# Notes

## Chapter 1

1. O salted sea, how much of your salt/ Is made of Portuguese tears!/ ... Was it worth it? Everything is worth it if the soul is not small./ Who aims beyond Cape Bojador/ Must aim beyond his pain/ God gave the sea perils and abysses/ But in it He mirrored the sky.
2. There were black slaves working as sailors on the boats from Lisbon to Africa.
3. This old term refers to the region encompassing the so-called *Petite Côte* south of Dakar, the Gambia, Casamance, and Guinea-Bissau (at least north of the river Geba).
4. Also as sailors, hence probably their name.
5. So ghastly were the massacres perpetrated during this campaign that Teixeira Pinto was destituted in 1915 — although we owe it to truth to add that he was also guilty of embezzling tax revenues.
6. Military pacification only touched the Western part of the country where so-called ‘animist’ populations live (Manjakus, Papels, Balantas, etc.). The Eastern part, in contrast, is peopled by Muslim Mandingos and Fulanis, long organized in powerful kingdoms. There negotiation was the rule.
7. Again, this is said only of the Western part.
8. The situation of Kriyol in Guinea-Bissau is thus not at all similar to that of Tok Pisin in Papua-New-Guinea.
9. The same process of revalorization of the creole took place in the Cape Verde Islands, even though military operations were mainly confined to the mainland. Recall that after a period of unity both countries became separate states shortly after independence.
10. When I speak of Portuguese interferences or influences, I refer of course to modern processes occurring after Kriyol was fully established.
11. At least they did at the end of the 1980s when the fieldwork on which this study is based was concluded. Note that very ‘light’ features such as the use of more or less integrated Portuguese simple pasts (e.g. *ištevi* ‘s/he was’ — P. *esteve* — instead of *i sta*) will not be considered.
12. ‘On closer analysis we even find that science knows no “bare facts” at all but that the facts that enter our knowledge are already viewed in a certain way and are, therefore, essentially ideational. This being the case, the history of science will be as complex, chaotic, full of mistakes, and entertaining as the ideas it contains, and these ideas in turn will be as complex, chaotic, full of mistakes, and entertaining as are the minds of those who invented them’ (Feyerabend 1988:11).
13. I know of only two other creolist works that match the present one in terms of coverage of one language (the only aspect I’m talking about here), viz. Bernabé (1983) on Martiniquais-Guadeloupean and Wurm & Mühlhäusler (1985) on Tok Pisin.

14. The philosophy of the official spelling is to have Kriyol look as ‘African’ as possible and, consequently, as dissimilar from Portuguese as it can be. Independently from hypotheses on creole genesis, I think this is a wise policy in terms of self-image and identity.
15. Kriyol official spelling shares with many others the deficiency of not proposing principled solutions for what is in fact the toughest, albeit regularly ignored, problem, viz. lexeme segmentation. As for my writing **n**, **u**, and **l** as separate words, the reason is not that I think it improves the system, but simply that I feel it makes things clearer when a Kriyol sentence is paired with a word for word gloss.
16. Kriyol words inserted in the text will appear in boldface. Other languages including Portuguese will be italicized.
17. Notice that the vowel systems of the surrounding Atlantic languages seem all to be based on the [+/-ATR] contrast.
18. In **dia** and like words, there is a tendency to realize /a/ as [e]. Vowel harmony is another area of Kriyol phonology that hasn’t been explored so far.
19. See next section for the realization of **n**.
20. Final vowels of verbs are also lengthened when followed by the object pronoun **l**: **n oja l** ‘I saw him/her/it’ [ŋoja:l]. Of course, vowels can be made longer for expressive purposes.
21. Palatal stops, while unknown in Portuguese, are ubiquitous in the Atlantic and Mande languages.
22. The only case where /ŋ/ seems to escape this limitation is **luña** ‘moon, menstruation’ from 16th century Portuguese *lũa* (Modern Portuguese *lua*). Here, there is a clear phonetic difference between **luña** and, e.g., **manga** ‘a lot’, which strengthens the case for the phonemicity of /ŋ/.
23. Judging by Barros’s transcriptions as reproduced in Schuchardt (1888), this might be a fairly recent change.
24. By ‘standard Portuguese’ I mean at that time the dialect of Lisbon as spoken by educated people (*classes cultas*).
25. The details of the change are much more complicated, linguistically as well as sociolinguistically (for a lucid explanation see Teyssier 1980). They are not relevant for the genesis of Kriyol, though.
26. Only in recent borrowings such as **šatya** ‘bug’ from *chateiar* can one find Portuguese /š/ written *ch* corresponding to another segment than /c/.

## Chapter 2

1. I will return to the issue of subcategorized vs. non subcategorized PPs.
2. Composition, which does not modify the argument structure or the syntactic category, is standardly distinguished from derivation, which does (see Matthews 1974).
3. One finds a small number of pairs such as **seku** ‘dry’ vs. **seka** ‘to dry’, or **purfumu** ‘perfume’ vs. **purfuma** ‘to perfume’, which look as though the verb was indeed derived from the adjective or noun as in P. *seco* vs. *secar*, *perfume* vs. *perfumar*. Such a process, however, is totally im-

productive in Kriyol which, for instance, has none of the verbalizations so characteristic of West African French, such as *essencer* 'fill up (with petrol)' (European French *prendrefaire de l'essence* — see Dumont 1983). I will therefore assume that *seku* and *seka* and other such pairs are independent reflexes of the Portuguese items that entertain no mutual relationship in Kriyol, other than that of being semantically cognate. By the same token, apparently composed verbs like *transmiti* 'to transmit' and all verbs bearing prefixes other than /dis-/ (see below) will be considered simplexes.

4. The Portuguese etymon of *diskisi* is *esquecer*. The first syllable was apparently "remotivated", which confirms the presence of the prefix in the Kriyol form.

5. On reduplication in creole languages, see Alleyne (1980:106-107); Boretzky (1983); DeCamp (1974); Ferraz (1979:58-60); Holm (1988).

6. There are also examples of *pudi* with an NP complement meaning 'be capable of', e.g. *no ta pudi ba kwalker aznera* (S) /we A can PAST any stupidity/ 'We would have been capable of any stupidity'. Such constructions seem rather marginal.

7. See West African French *durer* vs. European French *rester longtemps* (e.g. *J'ai duré à Dakar* 'I was/lived in Dakar a long time'). See also Krio *te* < English *stay* 'be a long time' (Fyle and Jones 1980). Portuguese *tardar* means 'delay, be late'.

8. Insofar as a predicate meaning 'to stay' is presupposed by *n tarda na Bisaw*, which cannot mean, e.g., 'I slept a long time in Bissau', whereas no such semantic operation is necessary in *n mora na Bisaw* 'I lived in Bissau'.

9. The meaning of *kiri* is actually more complex, as the 'a little' it denotes seems to contrast implicitly with 'not at all' rather than with 'a lot'. Hence its ironical overtone in an apparently self-contradictory sentence such as *no kiri yanda ciw* /we do-a-little walk much/ 'We walked quite a bit (to get there)'. *Kiri* is also a transitive verb meaning 'love' (P. *querer* 'want, love'). I have no idea whether the two items are in any way related. Also note that the Portuguese etymon of *yara* is *errar* 'err, make a mistake', a meaning that *yara* has kept as well. The origin of *jumna*, on the other hand, is unknown. Rougé (1988) tentatively proposes P. *dominar* 'dominate', but still marks the verb as *origine inconnue*.

10. See *inpregadu yara si diretor* 'The employee let his director down'.

11. For example, *\*fasi kila ku n na* as an output of *n na fasi kila* 'I'll do that' sounds still worse, if possible, than does (31').

12. The semantic converse of *jumna* may be *mayna* 'to postpone'. This is yet another modal verb, as shown by *pulisya mayna leba Ciku Bolo pa pulisya* (MSNP)/policeman postpone take CB to police/ 'The policeman didn't take CB to the police station right away'.

13. *Aktionsart* would be another possible label (see Comrie 1976).

14. That *yara*, etc. *are* verbs and not adverbs is indisputably shown by their position as head of VP. Compare, e.g., (26) with the almost synonymous (abstracting from presuppositions) *jila ta toma dinyeru purmeru* where *purmeru* (P. *primeiro*) is an adverb meaning 'first'. Although *purmeru* can appear in several different positions (see (1)), it is pointedly excluded from the position of *jumna* in (26): *\*jila ta purmeru toma dinyeru* is impossible. Conversely, *jumna* cannot appear in any of the positions that *purmeru* may occupy. Only when Aspect is not overtly marked, and the adverb follows the subject, may confusion arise (see fn. 18 below).

15. Note that (39) makes room for apparently finite [-SUBJ] VPs not dominated by S. We already encountered one example with the sentence **mininu kumsa ta cora** 'The child began to cry'. This issue will be taken up later.

16. Cf., for instance, Manjaku *kak* 'be/do again' as in *man kak ro wul* I do-again do it 'I did it again' (see Buis 1990:49-51). See also Rowlands (1959:100-101) for Mandinka. One shouldn't be too hasty in identifying an 'African' structure here, however, in view of such constructions as Occitan *o tornarai pas faire* 'I won't do it again'. Note further that P. *tornar* differs from its Kriyol cognate only in requiring a preposition to govern the dependent verb (as in *tornou a fazê-lo* 'S/he did it again'). The difference between Kriyol and Portuguese might therefore be more a difference of degree as to the extension and syntactic integration of the construction than of type.

17. This example makes clear that '(be/do) almost' is only a loose translation for a concept that might perhaps be glossed as 'expected/foreseen, etc. that X, but actually/maybe not X'. As a consequence of this basic meaning, *yara*'s Aspect value is usually accomplished, i.e. non overtly marked. The 'maybe not X' alternative is realized whenever the Aspect value is imperfective (see fn. 18).

18. Other possible orderings are **i bindi si karu kwas** or **i kwas bindi si karu**. With the latter possibility, *yar* and *kwas* are indeed categorially indistinguishable out of mere observation (see fn. 14), which probably also helped the transition from Ad-verb to adverb. Note that only *yara* is possible when Aspect is overt, a rare occurrence for semantical reasons (see fn. 17), and the Ad-verb is in its scope. Otherwise, sentences like **i yar na bin riku** /s/he YAR T come rich/ 'He may become rich' are perfectly acceptable, with *yar* clearly an adverb. On the other hand, *yar*, contrary to *kwas*, cannot appear in clause-final position. I have no explanation for this difference, although it is most certainly connected with the more creole status of *yar*.

19. For example, Manjaku *bêlenj a-faac* /cloth it-be-white/ 'The cloth is white', or Mandinka *jü kândita le* /water be-hot-PAST FOCUS/ 'The water is hot'.

20. The origin of *sedu* is probably P. *ser* 'be' having undergone final epenthesis and delatation. Remark that, as a sentence, **kil tera demokrátiku** 'This country is democratic' sounds much less natural than its topicalized variant **kil tera i demokrátiku** 'This country, it is democratic'. I will try later on to find an explanation for this fact. Note also that **kil tera (i) sedu demokrátiku** is deemed 'inelegant' by central speakers. But it is definitely not ungrammatical, in contrast to **\*kil tera sedu garandi** 'This country is big', for instance.

21. A variant of (61), **kil tera sedu ba demokrátiku**, is exposed to the same aesthetic judgment as its non-Past equivalent (see fn. 20).

22. For plural marking and plural agreement, both rather erratic phenomena, see Chapter 4.

23. For a concrete discussion of the problem, see Sebba (1986) and Seuren (1986). Another difference between undisputable verbs and adjectives is that the latter do not participate in the few derivational processes affecting Kriyol verbal items, viz. causativization and passivization (see Chapter 7).

24. See Pollock (1983) for a study of this distinction and its consequences in French and in English.

25. In (70), I assume that **ki** represents /ku i/ (see below). **Kabra amigu di kacur**, e.g., is not obviously ungrammatical, but central speakers find it wrong in some way (compare with adjective predicates). Dislocation in this case implies no particular emphasis or distinctivity. It is also

notheworthy that *i*, undisputably a pronoun in present-day Kriyol, occurs precisely in the position where the third person singular present copula *é* 'is' might occur in Portuguese. Compare, e.g., (66) with the Portuguese translation *a cabra é a amiga do cão*. Given the phonetic plausibility of /*ɛ*/ changing to /*i*/, there might be some kind of a conspiracy here which would help explain the emergence of noun predicates in Kriyol (see Wilson 1962).

26. A third variant, **sedu ba**, is also encountered. It is deemed inelegant, just as in the case of adjective predicates (see fn. 21).

27. Or rather its untropicalized version **n kontenti**, in order not to anticipate matters not yet considered.

28. A consequence is that **omi demokrátiku** 'the/a democratic man' should be considered an appositive construction rather than an N1-AP one. I do not think this is a problem, in view of the numerous N-N compounds encountered in Kriyol (e.g. **pis kabalu**, lit. 'fish horse', 'hippo' — see Chapter 4).

29. We are free to assume that, in addition to being freely instantiated, the [PRD] feature can also be assigned by the copular verb, like in English.

30. Bad English, but a literal translation!

31. Here is an example with an adjective predicate: **nya karu ka branku** 'My car isn't white'.

32. **Nega** 'deny, refuse' may be used as a modal verb to negate main verbs, as in this example: **disna oranu pasadu ku cuba nega cubi na ladu di Gabu** /since yesteryear past that rain refuse rain on side of Gabu/ 'For three years it hasn't rained in the region of Gabu' (see Pinto Bull 1989:212). It seems to me, however, that there must be a difference, at least stylistic (whatever that means), between **cuba ka cubi** 'It didn't rain' (lit. 'The rain didn't rain' — see below) and **cuba nega cubi** 'It refused to rain'. Only in nominalizations does **nega** appear to be the only available negative device (e.g., **nega cami bon** 'Not to drink is good' — see below).

33. In fact, the sequences /*ka na*/ and /*ka ta*/ are regularly written as one word — *kana* (or *cana*) and *kata* (or *cata*) — in native texts. This probably reflects some *Sprachgefühl*, but, given lexical conflation as an active factor here, not necessarily the actual syntactic structure. Note that sequences like /*ka bay*/, in contrast, are never written as one word.

34. One could invoke the noun **kasabi** 'annoyance' as a putative counterexample to my claim. Obviously, this item must be decomposed into **ka** and **sabi** 'sweet, nice'. It seems, however, that it ought to be analysed as being the lexical nominalization of the predicate (i) **ka sabi** '(It is) not nice', so that **kasabi** is a zero-level item which does not contradict the claim that **ka** never enters into NPs. Moreover, the case is quite an isolated one. Note also, as a further support for the verbal nature of **ka**, that 'reduced' sentences such as 'Not tomorrow' (as an answer to 'When do you intend to come?') are not possible in Kriyol. A full sentence has to be used: **i ka amanyan**, literally 'It is not tomorrow'.

35. Although there is nothing in Gazdar et al. (1985) on subjectless sentences, they must clearly be provided for by the theory. Actually, a tree such as (96) casts some doubt on the validity of the distinction of S and VP in terms of a [+/- Subject] feature. Within a strictly 'surfacist' view of things, it might be that an S node is redundant in (96), as well as in all sentences where COMP is not instantiated (see Borsley 1989).

36. An autonomous subject should probably be supplied in the semantic translation of (96). Incorporation thus appears as the result of the interfacing of the semantic and syntactic levels (see Sadock 1991).

37. For instance, we should imagine a dialogue such as the following: A. **jitu ka ten, nya bajuda ka misti riba** /way NEG have my girl NEG want return/ 'No way, my girl won't come back' — B. **pa ka bu torna cora mas enton** /PA NEG you do-again cry more then/ 'You might as well stop crying, then'.

38. *Never* as a predicate negation is also documented in English-based Creoles (see Holm 1988).

39. Sentential subjects as they will be characterized shortly must be distinguished from so-called 'nominalizations'. The latter will be studied in chapter 4 devoted to the NP. There is, to be sure, some measure of arbitrariness in this apportionment of topics. Either this or total confusion.

40. So-called 'null objects' will be examined in Chapter 6.

41. Alternatively, we might posit an ID rule  $VP[+sol] \rightarrow H[x]$ , where  $H[x]$  spells out as *noti*, and  $VP[+sol]$  mentions the fact that this particular VP takes *sol* as a subject (see the  $VP[+it]$  rule in Gazdar et al. 1985:115ff.). I am a little reluctant vis-à-vis this solution, however, because it entails that *sol* is not a 'normal' noun, i.e. is not marked [NFORM NORM], precisely in this rule, whereas it is an ordinary item elsewhere.

42. According to Pinto Bull (1989:166), *notsi* specifically means (or used to mean?) 'spend the day as a guest in somebody's house'.

43. Note that Portuguese *amanhecer* can also be used with an animate subject, as in *hoje amanheci com uma grande dor de cabeça* 'Today, I woke up with a terrible headache' (Teyssier 1976:185). The Kriyol equivalent of this, however, is not *mansi*, but rather *mandurga* (see below).

44. One also finds expletive *i* as a subject (*i na cubi* 'It's raining'). This less frequent construction may have been influenced by the Portuguese *chove* or *está a chover*.

45. Of course, it is possible to say things like *kil kaw kinti* 'That place (over there) is hot', or *bari kaw di bu tiya* 'Sweep your aunt's place!'. But the point is that bare *kaw kinti* or *bari kaw* cannot mean 'A certain place is hot' or 'Sweep a certain place!'. It must be this place where I am which is hot or to be swept.

46. To appreciate the full force of *kaw* in implementing this semantical shift, compare, e.g., *mininu kala yem* 'The child shut up (completely)' with *kaw kala yem* 'There was dead silence' (with *yem* an ideophone to be studied later on). Another possible, although marginal, candidate to the category of environmental expressions similarly constructed would be *kaw na fedi lit.* 'The place is stinking', i.e. 'Things are going badly'. Also, it should be clearer now why *sol* cannot be treated in the same way as *kaw*, since it does not partake of the same generic, quasi pronominal character, even though, like 'special' *kaw*, it is always definite, as a matter of contingent fact — there's only one sun in our sky — rather than of grammar.

47. Unless 'is always blue somewhere' is set off in quotes, i.e. mentioned rather than used. This is of course irrelevant to the present discussion.

48. Actually, this should not be specified in the grammar, since it clearly depends from our knowledge of the world that humans, not whales or tree-nodes have uncles (although the latter might have aunts).

49. See Gazdar et al. (1985:198) for the analysis tree to be assigned examples (107-112).
50. For obvious reasons, two phonological forms cannot be realized simultaneously, although portemanteau words such as *smog* or *mimsy* are certainly an attempt at such a tour de force.
51. To be read as: **mandurga** is a lexeme bearing the major class feature (MAJ) V, i.e. a verb, subcategorizing for two NPs, NP1, the subject, and NP2, a locational item. Its meaning is a compound relation RISE+GO-TO such as the riser-goer role is allocated to the subject, and the location role to the object.
52. As a proof of the disjunction of the place and the thing-in-the-place, note that one can sensibly say 'I went to Troy'. Also consider that, should **prasa** be pronominalized in (119), the adequate place-holder would not be the 3SG object pronoun (\***Maria mandurga I**), but the locative anaphoric adverb (**Maria mandurga la**), and likewise in (118).
53. Of course, the logic of underspecification implies plain 'go' (i.e., perhaps, GO) rather than 'walk', 'run', 'fly' and so forth (and equivalently for the three other possibilities). It is not implied by **Maria mandurga prasa** whether she walked there, or used any kind of vehicle.
54. For example, (117) does not mean that the cow is afraid of fires in general, in the sense of not being able to read about them or watch them on television. **Kil baka ta medi fugu** 'That cow is afraid of fire(s)' would be the right way of expressing such a bovine phobia.
55. With **Maria mandurga prasa** and similar examples, this solution is excluded simply because 'Mary rose early to the city' does not make sense. Unless *to* is taken to have full verbal force as in the Shakespearian line 'Let us to the castle' (Macbeth I.IV) — which leads us back to the lexical-semantic account.
56. The obsolete French verb *compisser* has exactly the same syntax and semantics. Also note that Portuguese *mijar* can be used transitively like its Kriyol reflex, but unlike English *piss* or French *pisser*. The following proverb, reported in Pinto Bull (1989:154), illustrates the interpretative lability of arguments in this context: **mursegu kuma i na misa Dews, riba di si kabesa ku si urina ta kay** /bat say-that it A piss God upon of its head that its urine A fall/ 'The bat says it will piss towards God, but its urine falls back upon its own head'.
57. This use is also found in 17th century dialectal Portuguese: *hir onde elle* 'go where he (is)' (Neto 1988:567).
58. If [1] is taken as the SUBCAT value for intransitive verbs, as in Gazdar et al. (1985). Additional refinements might be needed, as we shall see.
59. A variant of (139), **fedu boka**, literally 'have a stinking mouth', is fully idiomatic since it really means 'to be insolent'. Other expressions of this kind are **i linpu korson** /s/he clean heart/ 'S/he's nice', **i risu mon** /s/he hard hand/ 'S/he's stingy', **i kunpridu boka** /s/he long mouth/ 'S/he's full of her/himself', etc. Needless to say, **linpu korson** and like expressions cannot be confounded with an [NO, Adj] construction, as this would appear as **korson linpu** 'clean heart', literally meant (see Chapter 4).



60. Although it certainly has to do with the present problem, I leave the question of the equivalents of 'there is/are' for Chapter 6.
61. Recall that arguments are listed in order of decreasing obliqueness, i.e. subject last, direct or first object second-last, and so forth.
62. Indeed, *omi suta si spada* 'The man struck his sword' is either incomplete, or it has the somewhat improbable meaning that the man hit his sword with the most predictable instrument, i.e. his fist.
63. Notice the idiomatic use of *tras* in *i dudu si tras* 'S/he's crazy about him/her'.
64. The assignment is obligatory insofar as one cannot say such things as *\*nya diyanti bonitu* to mean that what is before me is nice. One has to say as in English *ke ku sta nya diyanti bonitu*. Note that, given the subcategorization patterns of movement verbs, *tras* and *diyanti* can very well be NPs in expressions like *riba tras* 'go back, retrace one's steps', or *bay diyanti* 'go forward'.
65. Also *i ten tris mis ku...* /it have 3 month that/ 'It has been 3 months since...'
66. This is usually reduced to *na metá di*.
67. Although *na kasoti* 'in/on the box' is ambiguous in a way *dentru di kasoti* isn't.
68. Provided the said surface is somehow attached to the ground. Compare *na luNa* 'on the Moon' with *\*riba di luNa* (unless it means 'above the Moon').
69. The same problem would arise with all other persons, except third person singular and plural, as *el* and *elis*, in addition to being topic forms, can be used as non clitic object pronouns. Thus, *e nterga pulisya el(is)* 'They turn him/her/them over to the policeman' is perfect.
70. Before *el/elis*, *pa* has the allomorph *par*: *par el/elis* 'toward/for him/her/it/them'.
71. The 'reduction' of *para* to *pa* is ordinary in colloquial Portuguese, in Portugal as well as in Brazil.
72. Name of the harbour area in Bissau. On August 3 1959 the workers went on strike. The bloody repression that ensued finally convinced the independentist leaders to give up all hope of negotiations with the Portuguese colonial power and to go over to armed struggle.
73. A 'lighter' synonym of *disna* is *de(s)di*, from Portuguese *desde* — whereas *disna* probably results from the amalgamation of /desde/ and /na/. Also recall the construction *n fasi kwatru dia (ku) n ka ciga prasa* /I do 4 day (that) I NEG arrive city/ 'It's been four days since I didn't go downtown' (compare Portuguese *faz quatro dias que não fui na cidade*).
74. Given its determiner-determined word order, Mandinka cannot enter the picture here.
75. The implication is present even in simple sentences like *i bay janan* 'S/he left at once', where the context generally makes it clear that s/he left in order to do something specific.
76. This is probably the reason why ideophones do not accompany noun predicates. Indeed, a noun predicate such as *i lingwista* 'S/he is a linguist' is not readily modifiable in terms of intensity or of manner, except in a metaphorical way ('S/he is very much a linguist', 'S/he is discreetly a linguist'). On ideophones in general see Welmers 1973:459-477, and references therein.
77. Unless indicated otherwise, all examples below have been elicited.

78. Actually, we may have here a cline rather than a dichotomy, insofar as at least two ideophones, viz. **fep** and **yem**, are compatible with several heads, and many 'ordinary' adverbs do not go with all heads for semantic reasons.

79. Notice **asa di falkon kudi na ramu di po wap i kebra** (MM) /wing of hawk go on branch of tree CLASH it break/ 'The hawk's wing clashed against the tree and broke'. Here, **na ramu di po** is subcategorized for by **kudi** which does office both as a noise expressor and as a movement verb — just like English 'clash' — and it therefore precedes **wap** which appears right at the end of the VP, as expected.

80. Hence the reasonable guess that **nan** might be a reflex of P. *não* 'no(t)'. A similar evolution from French *non* may be observed in Haitian, as in *ann'ale non!* 'Allons-y donc!' (Bentolila et al. 1976:348).

81. **Didume** might well be a synchronically unanalysable item, especially since **didu** never appears outside this combination with **me**. Neither has obvious etymologies in Portuguese or the surrounding languages. I wouldn't be surprised if **me** came from French *mais*, and **didu** from French *dis donc*, pronounced [di'dõ], an expression that struck the Iberian peoples as so typically French that they used it as a derogatory name for the French in the time of the Napoleonic wars (see Spanish *los didones*).

82. **Nan** and sometimes **de** may have the additional implication that some previous, possibly implicit proposition has {0} as its truth value.

### Chapter 3

1. Compare with the referential expression Demonstrative and its basic meanings "proximate", "distant", etc. The analogy will be pursued later on. The analysis developed here aims primarily to be a correct account of Kriyol facts. It has affinities, however, with the theory of creole tense/mood/ aspect systems elaborated by Muysken (1981). I also agree with this author in rejecting Bickerton's (1975) characterization of a universal TMA system for creole languages.

2. This is of course much more apparent in Indo-European languages where Aspect is a more central category, such as Russian or Yiddish. Note that some qualification is obviously necessary, since it is not clear in what way, e.g., Portuguese *chegou* 's/he/it arrived' is morphologically more complex than *chega* 's/he/it arrives'. (The same question applies to English, for that matter.)

3. In fact, the assumption should be generalized to a statement to the effect that non-auxiliary VOs are inherently undefined for TA in Kriyol. An FSD such as: [-N, +V, BAR 0, -AUX] ⇒ ¬[A] would ensure this. Predicates not preceded by **na** or **ta** are thus undefined for aspect, unless other factors contribute in inducing an aspectual interpretation.

4. I use "specificity" in the sense that a number of authors use "referentiality" (see, e.g. Bouchard 1984). The latter term, however, has proved much too likely to provoke severe misunderstandings. My notion of (non-)specificity as I will develop it below also strikes me as very much akin to the phenomenal/structural contrast of Goldsmith and Woisetschlaeger (1982).

5. Let me call thus a verb with its tense and/or aspect modulation (cf. German *Zeitwort* 'verb').

6. Actually, it is possible to overtly mark the Future using the auxiliary verb **bin** in combination with **na**. This will be examined later on.

7. Recall that aspectual auxiliaries subcategorize for [+V] items, which makes them incompatible with noun predicates unless a copula is present.
8. This difference may be responsible for the fact that mental state verbs with *tá* can have the inchoative interpretation in Saramaccan: *a tá-síbi dí tónɡo* 'He is getting to know the language' vs. *a síbi dí tónɡo* 'He knows the language' (Byrne 1987:46). As indicated, Kriyol *i na sibi lingwa* can only mean 'S/he will know the language'. On the other hand, (9) e.g. denotes repeated events of becoming fiercer, i.e. successive steps in an ever-ascending scale (see *kada byas mas*), rather than a continuous process as the Haitian and Saramaccan examples seem to do. I admit the distinction is subtle.
9. In contemporary European Portuguese (not in Brazil) it has been replaced by the *estar a fazer* construction, which is probably too recent to be relevant to creolization (see Teyssier 1983).
10. This is not, admittedly, a very common way of expressing oneself. The informant to whom I submitted the sentence did not reject it, but he would rather have put it as *n ta kunpra so karus branku* 'I only buy white cars'.
11. Not totally synonymous, because *n sta dwenti* appears to be less 'punctual' than *n dwenti*. This is why *sta* is frequently encountered with adjectives which do not easily denote rapidly evolving states, such as *dwenti* — as one is not normally ill a minute and healthy the next. However, *sta* does not seem to be ever obligatorily used, and, for instance, one can say *kaw kinti /place hot/* 'It's hot' as well as *kaw sta kinti* (see chapter 2 on weather expressions).
12. The notion of a non-specific perfective might well be self-contradictory, insofar as a perfected event is *ipso facto* interpreted as an occasion, a token-event (this being one basis for the distinction of Perfective and Past).
13. Probably a variant of the Cape-Verdean/ Saramaccan/ Martiniquais system is Cameroonian with marked Perfective (*don*) vs. marked Progressive-Habitual (*dí*) (Todd 1984). Of course, as repeatedly emphasized, all those "systems" are second-order objects whose cognitive reality is a matter for inquiry. As raw observations, they suffice for my present purpose.
14. Both examples are from the same tale, *Lubu ku Lyon* 'Hyena and Lion', as told me by an informant. Hyena and his family took refuge on the roof of their house to escape from Lion who came to punish Hyena for his misdeeds. Hyena's children are too weak to grab at the thatch and begin to fall off the roof one after the other. As they fall, Lion crushes them in the dirt (26). To his children's wailings of anguish, Hyena, who is not reputed for his sentimentality, answers only with (25).
15. Recall that *ciga dí* is a modal verb roughly meaning 'be/do already'.
16. Compare Portuguese *alguem que já me conhecia* or French *quelqu'un qui me connaissait déjà*.
17. This is probably because of the "background" interpretation which entails that one process should be constantly parallel to the other, disallowing an iterative interpretation.
18. A more central rendering of this sentence would be something like *un branku ku ta papya inglés, el ku komenda kil asasinus*, with no Past marking since we are dealing with a narrative of facts which is quite appropriately couched in the Perfective.

19. Note that this sentence demonstrates that a property assessed as essential (*ta*) can nevertheless be framed within the limits of a time period. Here, *ta* specifically implies that the property (contentment) was uniformly spread over the whole period.
20. For instance, Manjaku: *uci nanpëli ro ka tsëp* /if girl PAST A leave/ 'If the girl had left'; Mandinka: *n'íí y'aa dómo núnng a s'íí kónoo dími* /if you Simple-Perfective-Indicative it eat formerly it SI-Perfective-Indicative you stomach pain/ 'If you had eaten it, it would have pained your stomach' (Rowlands 1959:120). Note that the Mandinka SPI shares many semantic features with the Kriyol Past.
21. For example, in Santiago: *si bu staba la N ta papiaba ku bo* /if you be+PAST there I A speak+PAST with you/ 'If you had been there, I would have talked with you' (Veiga 1984:118).
22. São Vicente: *noS tud tá [=tava] fká kontent s' eS tá [=tava] omentá Zent salari* /we all PAST be satisfied if they PAST raise people wages/ 'We would all be satisfied if they raised the people's wages' (Veiga 1984:85); São Tomé: *e tava ba Sinema* /he PAST go cinema/ 'He had gone to the cinema' (Ferraz 1979:83); Papiamentu: *henter luna di desèmber su mama tabata puntra* /every month of December his/her mother PAST ask/ 'Every December her mother used to ask' (Jesus, Philipsen, and Pieters 1978:22).
23. The similarity between São-Tomense *î tava ka dumini ola kwe [=ku e] bi* /I Past A sleep when that he come/ 'I was sleeping when he came' (Ferraz 1979:83) and its Martiniquais equivalent *man té ka domi lé i vini* /I Past A sleep when he come/, is really something to marvel at. It is little to say that we don't know everything yet about the mutual relationships of the Atlantic creoles.
24. By abstract I mean not deictic, that is not referring to some autonomously represented time-span. This is what distinguishes *ba* from such adverbs as *awonti* 'yesterday' or *purmeru* 'previously'. Of course, *ba* is not isolated translinguistically; it finds, for example, a clear parallel in Tok Pisin *baimbai* or *bai*, meaning FUTURE.
25. The phonological processes responsible for this change are quite simple and general in the language. Intervocalic /b/ first gets fricativized, then it is deleted. The resulting hiatus [-ai-] is resolved by deleting the first vowel.
26. Kriyol thus achieves semantic effects which correspond closely to what is realized in Russian by contrasting perfective vs. imperfective infinitives, or in English by the use of post verbal particles. Such constructions as these, let me mention in passing, are irrefutable testimonies to the expressive richness of the language, and could be opposed to all contemptors of the creole languages — with little chance of success, I'm afraid.
27. In (73), the embedded clause is non finite. In (71), the embedded clause containing *ba ta* would be finite if *bin* was not present.
28. Recall that I call 'native' a text written by a native speaker. As already explained, such texts generally make use of non standardized, 'spontaneous' spellings. (71) is one such text. Actually, it is taken from a reader's letter printed in *Bombolom* ('The Drum'), the cultural supplement to the daily newspaper *Nô-Pintcha*. In the original version, *ba ta* is written *ba-ta*.
29. Notice that the same phonological process that affects *na bin* also affects the sequence /na ba ta/ yielding [na:ta].
30. It is immaterial whether the period is itself a time or an interval.

31. That is, the ‘otherwise’ clause should be interpreted as meaning, ‘if there is no such time i’’, without entailment for the interval between i’ and i.
32. That is to say, **ta** quantifies over complete indices when the proposition involves a generic entity and an attributive predicate; otherwise, it quantifies over partial indices reduced to times.
33. See chapter 5 for the apparently similar constructions exemplified in (3) and (5).
34. Again I am not ready to extrapolate to other languages.
35. Note that Portuguese uses the exact opposite of **kumsa**, viz. *acabar* ‘finish’ to express the same meaning: *Acabou de comer* ‘S/he has just eaten’. Clearly, *comer* has no Tense or Aspect value in this construction, which explains the lexical reversal.
36. Note that the noun and the pronoun cannot exchange their positions: \***e pasa mininus obi...**

## Chapter 4

1. The definition of ‘common noun’ I’m using here is basically semantic. A noun is a function from an entity to a truth value. That is, the meaning of ‘horse’ is the relation according to which a given entity does have the property of being a horse (see Dowty et al. 1981; also Pollard and Sag 1987:Chapter 4).
2. With kinship terms, there is a tendency to use more acrolectal words such as **irmon** ‘brother’ vs. **irman** ‘sister’ (P. *irmão-irmã*) or **fiju** vs. **fija** on the model of Portuguese *filho-filha* ‘son-daughter’ (Kriyol *fundu fiju macu/femya*, with **fiju** meaning ‘child’). No such decreolization occurs, however, with names of animals.
3. Contrary to most, this item was probably borrowed from Portuguese *guarda-chuva* ‘umbrella’.
4. **Ba-** must be one of the most anciently described Kriyol grammatical items since it is mentioned in Bocandé’s 1849 note on the language (reproduced in Schuchardt 1888). Bocandé mistook it for a plural marker. See below for the use of **ba-** with interrogative **kin** ‘who?’.
5. Note **kabalindadi** ‘wickedness, wicked actions/behaviour’, from /*kabali*/ lit. ‘not-(be)-good’, a virtual noun that does not seem to exist of itself, but which finds a clear parallel in **un kasabi** ‘a piece of trouble’ (lit. ‘a not-(be)-nice). Here would be examples of nouns formed from VPs. As they are quite rare — limited perhaps to these two items — I did not include them in my review of noun composition. Also worthy of mention are nouns like **ma-rapidu**, lit. ‘more fast’, which designates a kind of home-made brandy.
6. The one case I know of where the Agent denoted by /-dur/ is not a human is **kobadur** ‘hoe’ from **koba** ‘dig holes’ (discounting recent borrowings like **komputadur** ‘computer’).
7. Epenthesis also occurs in Portuguese (e.g. *mulheres* ‘women’ from *mulher*). The vowel spelt *e* is now mostly silent in Europe. It was pronounced something between /i/ and schwa until the 19th century.
8. Similarly on the hearer’s side, ‘Interpret plural morphology on a noun as meaning that more than one, etc...’ Note that this grammar is also similar to that of Manjaku, Balanta, etc.
9. Of course, inherently mass or non-count nouns such as **yagu** ‘water’, **arus** ‘rice’, and so forth are never marked as plural. They are not the interesting cases.

10. In other words, Kriyol under PMP II extends to a large and basically indefinite array of things what English only applies to objects whose particles are small enough, like sand, rice, etc.

11. I do not adopt the so-called 'DP Hypothesis' (Abney 1987) here mainly because it is not useful to the primarily descriptive goal I set to myself. And also because I think that construing determiners (or functional categories in general) as heads makes sense in the semantics, not in the syntax.

12. In Kriyol at least. With the same analysis, Ancient Greek or Arabic would indeed present inverted values for markedness.

13. A 'to' as well as the impersonal passive are clear lusitanisms. They have no bearing on the argument being made, except for the possible support provided by the latter.

14. Of course, one may also imagine that the speaker-hearer world is such that *pilon* is in fact treated as *porta* is. It is merely a consequence of underspecification (see below) that both construals are always available from an outsider's point of view.

15. As mentioned above, there is a correlation between pluralization and specificity. It is hard to assess, though. True, *omis bin* lit. 'men came' is more likely to be interpreted as 'the men came' (P. *os homens vieram*) than as 'men came' (P. *homens vieram*, French *des hommes sont venus*). But this latter reading always remains available. Two things, in fact, should not be confounded. One, which is at issue here, is the possibility or relevance of identifying specific individuals in a set. The other, which was discussed in connexion with pluralization, is the feasibility of conceiving of a set without any reference at all to the individuals that compose it. Plural marking and specificity are thus not coextensive, but orthogonal dimensions with a certain amount of interfacing.

16. The same evolution may be observed, at a much more advanced stage, in Cape-Verdean (see Almada 1961; Meintel 1975).

17. Apropos (29), note the empty specifier of *elikóteru*. As it is the first time a helicopter is mentioned in the narrative, I translated with the indefinite article. In different circumstances, a translation with 'the' might have been appropriate. The point is again that Kriyol speakers do not have to make a choice and may remain content with the mere denotation of the entity.

18. *Nha* as a reduced form of *minha* 'my (fem.)' exists as a dialectal variant in European Portuguese. The remaining items in the Kriyol paradigm have been profoundly modified vis-a-vis the source language. Compare Portuguese *vosso/a, seu/sua, nosso/a*.

19. This construction is only used with *nyu/nya*, the polite address pronoun for men and women respectively (e.g., *kasa di nya* 'your house' — see later on).

20. *Sis* 'six' is more *fundu* than *seys*. Of course, *vinti-i-un* 'twenty-one' is realized [vintiyuN]; likewise *trenta-i-dus* 'thirty-two' [trentidus].

21. It is worthy of remark that the Kriyol numeration system has 10 as its base, which sets it apart from the systems used in the Atlantic languages which generally have 5 as a base. It is compatible, on the other hand, with the system used in Mandinka. The old numerals *des-ku-un, des-ku-dus*, etc., in particular, look like an overt imitation of Mandinka (e.g. *táng náng killing* /ten and one/ 'eleven').

22. Ordinal numbers are also a cause for difficulties in Portuguese, where their usage is ordinarily discontinued above ten (see *o sexto século* 'the 6th century' vs. *o século 16* 'the 16th century').

The substrate languages, on the other hand, all have regular processes for deriving ordinals from cardinals.

23. **Tudu** is further subject to some sort of ‘quantifier floating’ to be described below.

24. For example, **nin si awla kriyol ka tene** (I) /not-even its lesson Kriyol NEG have/ ‘There aren’t even Kriyol lessons’; **nin e ka na fala nada** (I) /not even they NEG A say nothing/ ‘They won’t even say anything’. I found no examples, on the other hand, of **nin** meaning simply ‘nor’. ‘Neither X nor Y VP’, for instance, has to be rendered as ‘X and Y not VP’.

25. Negated VPs often presuppose their contrary, as is well known (consider, e.g., ‘The steak is not overdone (today)’). The contrary of a negated NP is the existence of at least one or some token(s) of the entity.

26. Portuguese *manga* ‘sleeve’ has the now obsolete meaning ‘gang, troop’, which probably explains the semantic shift of Kriyol **manga**.

27. The latter construction may certainly be imitated as **?kil bajuda kunpridu i bonitu**. But this is blatantly lusitanized Kriyol, especially for the use of **i** ‘and’ which is not a Kriyol item (see below).

28. Non argumental pronouns have been variously called ‘detached’ or ‘autonomous’ or ‘strong’ in the literature. Note that this dichotomy is a recurrent feature in all substrate/adstrate languages.

29. **Nyu** and **nya** are commonly supposed to be derived from P. *senhor* ‘mister’ and *senhora* ‘madam’. This is quite possible given a diachronic change somewhat along the line /seˈnoɾ/ > [sɲu/ > /ɲu/. Given this, **nya** must obviously be considered an analogical formation on **nyu** rather than a direct derivation from *senhora*.

30. Up to the 16th century, *mim*, the Oblique member of a paradigm also consisting of Nominative (and non-A) *eu* ‘I’ and Accusative-Dative *me* ‘me’, had a non nasalized variant *mi*. Note also that *vós* was the polite form of address at the time. It is remarkable that the non polite 2nd person *tu* never entered Kriyol or the other Portuguese-based creoles of Africa (and is nearly absent in Brazilian Portuguese as well), just as French *tu* is absent from the French-based Caribbean creoles (except Guyanais and Louisianais). This looks very much like a distinctive feature of the Atlantic creoles whose ultimate rationale must be partly sociolinguistic, partly a set of complex conflation processes between the source and the substrate languages (see below).

31. Kriyol **i** ‘s/he/it’ may be the ultimate reduction of Portuguese *ele*. There is also the possibility that *ele*, pronounced somewhat /eli/ in the 16th century gave birth to **el** and to **i** at the same time, through reanalysis of sentences like [ele VP] into [el[i VP]]. A straightforward derivation exists for **e** ‘they’ from P. *eles*, the intermediate stages of which are represented in Cape Verdean dialects (*ews*, *es*).

32. This is only fully true in the first singular (*eu*) and second singular intimate (*tu*) persons, and even there the contrastive force is often quite slight, certainly not sufficient to justify that *eu* or *tu* in *eu escrevo* or *tu escreves* be systematically assigned to a topic, extra-clausal position rather than to the subject position. Expressions such as *tu, tu escreves* are encountered. *Nós*, on the other hand, is regularly contrastive, to the extent that it is not replaced by *a gente* ‘people, we’ which functions like a subject pronoun. *Você* and *vocês* also function like subject pronouns. In short, this is one more case where the blunt notion of null subject or pro-drop language appears very unsatisfactory. In the third person, on the other hand, the overt pronoun (*ele(s)/ela(s)*) is frequently used without any particular discourse-functional significance. In Southern dialects of European

Portuguese, there are even instances of *ele* used as an expletive subject, e.g. *ele está a chover* 'It's raining', which is not admissible in the standard variety (see Kriyol *i na cubi*). This is all to say that the difference between Kriyol and its source language may not be as frontal as it may appear to a cursory glance.

33. A-pronouns are obligatorily X0s. Therefore, bar level need not be specified in their lexical representations, given an FCR [+PRO] & [+A] ⇒ [BAR 0]. As we shall see, non-A pronouns are different in this respect.

34. The syntax line of the lexical entry specifies the syntactic position of the element as determined by the relevant ID rules and LP statements.

35. See below for non-A pronouns following VP[+SUBJ].

36. In the logic of Autolexical Syntax, there is no difficulty with having syntactic Case features assigned to nouns, irrespective of whether those features find a correspondent expression in the autonomous morphological dimension. As Kriyol and countless other languages show, it is not an all or nothing matter, in any event.

37. I am aware of the impressionistic and debatable character of this argument. Note that (British) English has the same problem as shown by the acceptability contrast between 'He sent me it' and '?He sent me you'. I see no explanation for this contrast except in the semantic difference between 'it' and 'you', however hard it may be to extricate. Kriyol makes no formal distinction between humans and non-humans in the third person. It is my experience, though, that in such sentences as (78) *el* is always given a non-human interpretation. Moreover, I have the impression — but no really conclusive evidence — that plural *elis* is as unacceptable as *amí*, *abó*, etc. If this is a fact, it would fit in the explanation since *elis* almost always refers to humans because of the semantics of the Kriyol plural (see above).

38. The usual practice of having TOP or FOCUS nodes in the syntax strikes me as a very sloppy way of mixing up quite distinct dimensions. Of course, the discourse-functional force of non-A pronoun offers sufficient explanation for their being obligatorily outside the minimal sentence. No further account of why they can't be subjects or objects is thus needed.

39. As shown by (89), there is no correlation between the selection of the connected argument and the position of the non-A pronoun. The fronted variant *amí Kornobif, Sardinya ta nperga n kornu* would be as good as (86), minus the indignant overlay.

40. Note how (93) confirms the inability of non-A pronouns to assume any argumental function. *Abó* cannot be the subject of *tene* even by proxy, through a null position (to be assumed insofar as *ku* is a realization of Comp which is not the subject of *tene*, contrary to English 'who' in 'you who have' — see below).

41. In the logic of this treatment there lies the eventual demise of UDCs inasmuch as they constitute a last remnant of transformations (see Sadock 1991a) — although they can also be conceived of as compacted ways of stating a syntax-semantics interface, one that is perhaps too syntax-bound, though (see Chapter 6).

42. This is not so much ill-formed as strange, the kind of things nobody would utter or be likely to hear unless pressed by a linguist.

43. *El ku manda* is a cleft or focalized construction to be studied in the next chapter. It does not contradict the claim that non-A pronouns are not arguments.



44. According to Doneux & Rougé (1988:30), sentences like *e piskadur* 'They (are) fishermen' are grammatical. Although I never encountered any such myself, I'm ready to accept their claim. The fact remains that *elis i piskadur*, with *i* referring back to *elis*, is the most common way of predicating the fisherman quality of several people.

45. Of course, the aspect of the verb predicate makes a difference. 'I write linguistics' means almost the same as 'I'm a linguist'.

46. *Es(is)* is obviously the same item as the demonstrative specifier *es* that was studied earlier, both deriving from P. *esse*. Apart from the syntactic difference, both items are distinguished, however, by the fact that (i) pronominal *es* never reduces to *e*; (ii) specifier *es* has no plural form. *Kila*, on the other hand, probably results from the amalgamation of \**kil la* 'that there'. It is now one unanalysable unit, as shown by its having a plural form.

47. There is then nothing to prevent *si kabesa* in (112) from referring back to the subject of the higher clause, *kacur-di-mangu* 'mongoose', in spite of all binding conditions or their equivalents.

48. Similarly, [POSS *kabesa*] is barred from subject position — as reflexive anaphors standardly are — only insofar as a 'literal' interpretation is not allowed, or even mandatory as in, e.g., *si kabesa na de Jon* /his head A hurt John/ 'John's got a headache', a perfectly good expression, even though *kabesa di Jon na de I* might be preferred in everyday speech.

49. As already mentioned, only *se* is overtly anaphoric in Portuguese. The obligatory coreference of, e.g., *me* 'me' and *te* 'you' to the subject in *olhei-me* 'I looked at myself' or *olhaste-te* 'you looked at yourself' is certainly due to other factors than syntactic binding (see, e.g. Keenan 1988).

50. There is of course an obvious semantic connexion between both shades of meaning. Neither is it an accident that 'head' is so often chosen as a signified to express reflexivity. Common substrate can probably be invoked in the case of Haitian, Kriyol, and Wolof. Some kind of cognitive universal is more likely to be the explanation, however, when one takes Arabic into the picture.

51. By language routines, I mean the fact that (112) is a proverb, *sibi di si kabesa* 'mind one's own business' is a fixed phrase, and so forth.

52. Not only pronouns can be complements of *di*: *es i di Jon* 'This is John's', *es i di nya kolega* 'This belongs to my colleague'. As arguments, [*di X*] expressions may also be subjects, e.g. *di Jon pirdi* 'John's got lost'.

53. *Sil/selis* have *sew/sews* as dialectal variants, which suggests Portuguese (*o seu(s)*) as an etymon. Note however that the Portuguese item is not inherently reflexive.

54. Thus, \**n sibi di sil* is bad (OK *n sibi del* 'I know about him/her/it). *N sibi di mi* or *n sibi di nya kabesa* are of course both possible (see below).

55. Example (119a) should thus read \**i ta papyia senpri di di sil*. That the two identical prepositions get conflated into one by some morphophonological process is by no means an extravagant assumption.

56. I limit myself to arguments. English also includes adjunct quantifying pronouns referring to place ('somewhere', etc.), time ('sometimes'), and manner ('somehow', etc.). Except for a few items (e.g. *algures* 'somewhere'), their status in Portuguese is unclear. They practically do not exist in Kriyol.

57. There are examples of the Manjaku pattern, however: **tanburis kala yem bu ta pensa nos algin ka sta la** (FJGK) /drums be-silent IDEO you A think whether somebody NEG be there/ 'The drums were silent all of a sudden, you might have thought nobody was there'. Note that this is in a counterfactual context, and **nos** includes a negative polarity (see Chapter 5). As an independent utterance, **\*algin ka sta la** to mean **ningin ka sta la** 'nobody is(n't) there' would not be acceptable (although **un algin ka sta la** 'a (certain) person isn't there' would as a matter of course).

58. For the quantifying nature of AUX aka I(NFL), also see Pollock (1989).

59. In fact, we might push the autosegmental analogy further by autonomizing quantification on a separate plane within semantic space. I let it to the reader to elaborate what it would look like.

60. Of course, this also can be accounted for in terms of parallel representations pairings. The relevant pairing, however, would concern a different portion of the interface than in the case of NEG-prop. In the spirit of the preceding footnote, this implies we would also need an autonomous agreement plane only for the subject and verb positions, with the provisos that (i) verb and subject agree only for those features which may be instantiated on both (the regular CAP); (ii) agreement is limited to NEG in Kriyol, and it is optional.

61. **Fidi jinjirba**, lit. 'to slit the gums', designates the young girls' cosmetic practice of having their gums tattooed black.

62. **Tudu**'s 'rightward floating' should not be confounded with **tudu** appearing in the postnominal specifier position (see above). Here **tudu** is a pronoun, which replicates **e**, but does not modify it.

63. Sentences like 'He hits whoever he sees' cannot be translated directly, but must be rendered as **kin ku i oja i ta suta** (I) 'Whoever (it is that) he sees, he hits (him)'. On this, to my knowledge, poorly studied issue of indefinite (or, better perhaps, distributional) WH-words, there is an excellent article by Schuchardt (1893). Headless relative clauses is another name for constructions such as (87), (114), and (137), one I will not use much, however, as I do not find it really enlightening.

64. **Kaw** is a place, **faka** an instrument; as an example of means, consider **kaminyu di bay kasa** 'the way home'. In fact, all these expressions would be best translated as compound nouns, e.g., in German, **faka di torna** as *Rachemesser*, **kaw di fola baka** as *Rindfleischzerstückelungsart*, and so forth.

65. Focalized constructions, which are formally a department of relative clauses constructions in Kriyol, will nevertheless be delayed until Chapter 6.

66. [COMP ku] appears thus as the Kriyol equivalent of the [+R] feature of English (see Gazdar et al. 1985:153ff.)

67. This is registered in Marques de Barros's version of the Prodigal Son as given in Schuchardt (1888:302): **storia d'mnino kbá-botâ sê-ardança** (**storia di mininu ku ba bota si ardansa**) 'The story of a child who throws his heritage away'. It is heard in Bissau, albeit less systematically than Marques de Barros's transcription would suggest. The Portuguese etymon of **ku** is of course P. *que*, itself a COMP-form rather than a relative pronoun.

68. Actually, the commonest variant one hears has a neutralized vowel akin to [ʌ] — hence Doneux & Rougé's equally valid decision of choosing **ke** as the archimorpheme. (But **ku** has the advantage of allowing an easy distinction with **ke** 'what(ever)', a different morpheme even though it proceeds from *que* as well.)

69. So that [2SG] should be added to the feature matrix of NP in (159).

70. Compare English 'that which I lost':

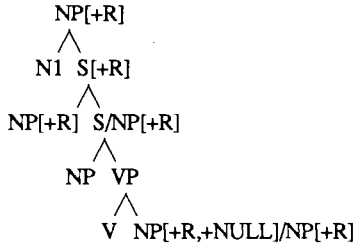

71. See English 'the people of which I heard' vs. \*'the people of that I heard' (but OK 'the people (that) I heard of').

72. **Di** would be a possible candidate (see *n pirdi kurida di kil manera* 'I lost the race in that way'). **Del** is nevertheless not accepted in a sentence like (164), probably because the preposition is too empty semantically. The alternative option of construing *manera ku* as a complex complementizer does not strike me as a very wise one, given the existence of *kuma ku* 'how' (see next chapter).

73. For an example with an initial NP, consider *po tudu tarda ku i tarda na yagu i ka ta bida lagartu* /tree all stay that it stay in water it NEG A become crocodile/ 'No matter how long a tree stays in water, it will not turn into a crocodile' (Montenegro 1990:11).

74. In other words, the RC plays the role of a possessive specifier (see English 'for all his doing'). For some reason, however, one cannot say \**pa tudu si fasi*.

75. **Tudu** appears thus as an instance of those 'free choice' quantifiers one sees connected with concessive expressions in many languages (see König 1988).

## Chapter 5

1. Henceforth 'complement sentences' *tout court*.

2. Doneux and Rougé (1988:58) state that 'D'autres verbes ou constructions verbales prennent ke comme introducteur de la subordonnée', and they give two examples: *n tene sertesa ke n kungsi* 'I have the certainty that I know him' and *i tarda ke n konta l el* 'it's been a long time since I told it to him'. The first example can easily be analysed as a case of relative clause construction (headed by *sertesa*, an NP). As for the second one, I would personally assess it as pertaining to a rather decreolized variety. The 'deep' version would be *n tarda konta l el* (see Chapter 2). I therefore maintain my statement, given the sociolinguistic limits I set to myself.

3. **Pa** (from P. *para* 'for') is also a preposition meaning 'for' (*n fasi l pa bo* 'I did it for you') and an adjunct complementizer meaning 'in order to, so that'. Examples from this latter function will be given below.

4. GPSG's FCDs and FCRs are kinds of meanings postulates, in any event. See Kihm (1992a) and below for an application of meaning postulates to the causative verb issue. The inventor of the device is of course Carnap (1947).
5. In the following, VP must be understood as short for 'predicate'.
6. Unless the language does not allow unmarked verbs at all, of course. Romance languages do not fall into that, possibly void, category, however, since the infinitive is commonly and, I believe, rightly considered the unmarked member of the verbal paradigm. Subjunctive is also a relatively unmarked member of the said paradigm (see Picallo 1984).
7. I translated *nega* with 'refuse'. Actually, its real sense is more like 'say no' (see P. *negar* 'negate').
8. See, for instance, colloquial European French *comme quoi* 'as what' (*Il a dit comme quoi il viendrait* 'He said he would come').
9. Although I do not wish to make too much of the observation, the initial alliteration of *kuma/kó* and *fala/fo* is certainly a matter for wonder.
10. In Mandinka *kó* can be followed by a mention of the addressee (*a kó ò ye* /he say they to/ 'he said to them'). But note that the lexeme referring to the addressee is governed by a postposition, not by the verb itself. In contrast, no direct NP object can follow *kó*, which must be replaced with *fo* (*a mang féng fo* /he NEG+A thing say/ 'he said nothing' — compare *i ka fala nada*, not *\*i ka kuma nada*).
11. The apparently simpler solution of generating *kuma* under a V node marked C+ and specifying it as taking no subject, as in Borsley's analysis of English *that* (1989), is not available for reasons that will become clear below. It may be freely applied to *pa*, in contrast.
12. By 'mental act' I mean speech act as well as instances of thinking, believing, etc.
13. For instance, Haitian *Jan pran koupe pen* /John take knife cut bread/ 'he cut the bread with the knife' implies that the taking of the knife and the cutting of the bread constitute one complex action, not a sequence of two as in the erroneous English translation 'John took the knife and cut the bread'. This is precisely why there can be but one subject, so that *?Jan pran koupe Pyè koupe pen* does not make sense, whereas 'John took the knife and Peter cut the bread' (*Jan pran koupe epi Pyè koupe pen*) is flawless.
14. Corresponding to instrumental (as in the preceding footnote) or locative serial verb constructions, Kriyol uses either prepositional constructions (*Jon korta pon ku faka* 'John cut the bread with the/a knife') or special lexemes (*Jon leba pis na fera* 'John brought fish to the market'). Let me add that I suspect both accounts, the serial verb one and the main verb plus gerundive one, not to be in fact alternatives in general, and to be amenable to the same explanatory schema, perhaps aptly represented by (19). The crucial difference would then be whether the two (or more) consecutive verbs are semantically redundant or not.
15. This includes also modals like *pudi* 'can' (*\*i pudi kuma...*) and Ad-verbs like *torna* 'do again' (*\*i torna kuma...*). All such meanings have to be expressed using *fala*.
16. Other values exist, as we shall see later on.
17. The *f* exponent on *fala* and *kuma* means 'factive'.
18. For example a verb bearing a COMP+ feature and specified as having no subject as in Borsley's analysis of English *that* (1989).

19. The *d* exponent on **fala** and **kuma** means ‘declarative’.
20. It seems that, in Guadeloupean at least, *dí* ‘say’ could function at a time in a way parallel to **kuma** or English-based creoles *se* (Hazaël-Massieux p.c.).
21. ‘He killed her by saying he would leave her’ is certainly a meaningful utterance, but it cannot be translated as \***i mata l kuma i na disa l**.
22. I confess myself at a loss to submit an etymology for this item. Final /s/ probably represents *se* ‘if’ (Kriyol *si*). A reduction of *nāo sei (se)* ‘I don’t know (if)’ has been proposed in order to explain initial /no/, but I’m not convinced. Pinto-Bull’s (1989:315) translation of **nos** as *talvez* ‘perhaps’ is justified by examples like **pera n n say nos n ta oca kunpadri** (HGCS) /wait me I go-out NOS I A find buddy/ ‘Wait for me, I’m going out see if couldn’t find some buddies’. Analysing **nos** as an adverb here seems indeed to be the simplest thing, although an alternative solution can be envisaged (see below).
23. Part of this overlapping has sociolinguistic value. After **ka sibi** ‘not know’, **nos** seems to correspond to the most *fundu* usage, **kuma** being less so, and **si** the most *lebi*. After verbs meaning ‘think’, on the other hand, **nos** and **kuma** are not semantically identical, so they do not seem to be aligned on such a scale (although it may be true that speakers of markedly decreolized varieties tend to use it seldom).
24. Manjaku *uwal* ‘time’ functions very much like Kriyol *ora* (see Buis 1990:66).
25. Actually, the directionality of the linking might well go from the gerundive, interpreted as perfective, to the matrix verb. This would explain the temporal relationships mentioned above.
26. **Antis** (P. *antes*) also appears as **antus** or **antu**. Likewise, **dipus** (P. *depois*) has a variant **dispus**, possibly out of contamination through **disna**.
27. Note that **te** and **tok** stand in complementary distribution, since the former selects NPs only, and the latter clauses only. This might constitute an argument in favour of the proposed analysis, as does the unconventional CVC syllabic structure of the item. (The final bracketed /i/ is almost always unrealized, even when the following word begins with a consonant.)
28. **Pabya** is probably made up of **pa** ‘for’ and a reflex of P. *via* ‘way’ (compare Cape Verdean *pamodi* ‘because’). In conjunction with **di** ‘of’, it too can function as a preposition (see **pabya di ke** ‘because of what, why’). The etymology of **suma** is unclear.
29. Perhaps the locative clause is not exactly adjoined in (57) insofar as **leba** can be said to subcategorize for a place complement. But this is irrelevant. The construction and, probably, the syntactic structure would be the same if the main verb was one for which this claim can obviously not be made, e.g. **oja** ‘see’ (as in **n oja l (n)unde ku i ta mora nel** ‘I saw him/her where s/he lives’). The nominal character of **nunde** is apparent in such constructions as **n na bay nunde tiw Jon Santin** (HGTD) ‘I’ll go to uncle Jon Santin’s house’. Compare, e.g., Wolof *dinaa dem suma kër nijaay* /A+1SG go my house uncle/ ‘I’ll go to my uncle’s house’, where the relationship between *kër* and *nijaay* is no more formally marked than that between **nunde** and **tiw**.
30. **N oja i na pasa** is of course grammatical as a variant of **n oja kuma i na pasa**. But ‘I saw (that) he was passing by’ is certainly not the same utterance as ‘I saw him passing by’ (it does not imply actually seeing the person, for instance).

31. Note this partially decreolized utterance recorded on the radio: **i sigi senpri na lutandu pa unidadi afrikanu** /he follow always A fighting for unity African/ 'He never stopped fighting for the African unity'. For an analysis of gerundives in English and beyond, see Emonds (1985).

32. Compare Manjaku *Upa a-pe Domingo pëřëmb* /Upa 3SG-surpass Domingo 9+be-fat/ 'Upa is fatter than Domingo' (Buis 1990:23), or Wolof *gaalu kii moo gën rey gaalu kale* /canoe+U this-one EMPH+3SG surpass be-large canoe+U that-one/ 'This man's canoe is larger than that man's canoe' (Sauvageot 1965:191). As far as term ordering is concerned, Kriyol stands closer to Atlantic languages than to creole languages as exemplified by Principense: *rima me maSi forti pasa mi* /brother my more strong surpass me/ 'My brother is stronger than me' (Ferraz and Valkhoff 1975:23).

33. For **medi** 'fear' at least this assumption is supported by the fact that the Kriyol lexeme is related to the Portuguese construction *ter medo de* 'be afraid of', not to *medir*, which means 'to measure'. The Kriyol reflex of *medir*, viz. **medi**, although homophonous with **medi** 'fear', is kept distinct from it by the fact that it is directly transitive (**i medi n** 's/he measured me').

34. Note that a pronominal complement of **di ki** will bear Oblique case (**i ma forti di ki mi** 's/he's stronger than I am'), unlike Modern Portuguese (*é mais forte do que eu*), but like 16th century Portuguese (*é mais forte do que mim*). This might be an argument to surmise that the more Portuguese construction is in fact the oldest, and that it was subsequently 'Africanized'. Naturally, there can be no certainty in such matters.

35. In this review of comparative constructions, I only mentioned superiority ('more than...'). Comparatives of inferiority ('less than...') do not seem to be used in basilectal Kriyol. In other varieties one may find constructions like **menus Adj ku...**, direct borrowings from Portuguese (*menos Adj que...*). Finally, equality or identity is expressed with **suma 'as'** (e.g., **i kunpridu suma si irmon** 'he is as tall as his brother').

## Chapter 6

1. A non specific or syncategorematic interpretation may thus be forced upon the topicalized element — see, e.g., expressions such as French *Le théâtre, j'adore*, and the debate around null objects in Italian and Portuguese (see Rizzi 1986; Raposo 1986). Apparently, this is not the case in Kriyol or in English. In any case, English topicalization, insofar as it does not contrast with left-dislocation (at least in the standard dialects), is certainly not to be analysed like Kriyol topicalization, and may well involve a null object, as in the transformationalist or phrase-structure treatments of the construction.

2. See Gazdar et al. 1985:106, 142ff. Although this will be the unmarked case, there is no a priori reason for limiting [+RES] to pronominals in view of the well-known category of 'quality expressions' such as 'the fool', 'the SOB', etc. (see Milner 1978; Ruwet 1982).

3. For simplicity's sake, I remove the **un byas** 'once' component from (14). One more S adjunction would be all that is needed to accommodate it.

4. Right-dislocation was touched upon in Chapter 2. I will maintain it constitutes the same phenomenon as LD, but for a slight pragmatic difference (e.g., **n tisi l na nya kandonga, es minjer** would sound most natural preceded by **sin** 'yes' or some confirmative expostulation, as

an answer to *es minjer, bu tisi l na bo kandonga?* ‘This woman, did you carry her in your pick up?’).

5. Examples (2) and (3) would be perfectly grammatical and semantically unchanged with resumptive pronouns; likewise (6): *kasamenti di omi beju, bu ta pirdi kel* (*kel = ku el* ‘with it’). It is not so clear, on the other hand, that we may have LD constructions where SLASH takes the value [+NULL] rather than [+RES], i.e. unresumpted topicalization with transitively used verbs licensed by rule 1 rather than by rule 7. Speakers vary a lot in their judgments concerning sentences like *es minjer, n tisi na nya kandonga*, so it is not clear that they are indeed acceptable. I will return to this issue.

6. Actually, it’s the second position that must be unrealized, since \*[[*bu ka mata ø*] *nada*] is excluded.

7. Indeed, *bu ka mata nada* is fully synonymous with *bu ka mata nin un kusa* ‘you didn’t kill (not) a thing’ and *nada bu ka mata* with *nin un kusa bu ka mata* (see Chapter 2). In the latter example, however, resumption is acceptable (*nin un kusa bu ka mata l*).

8. Perhaps as the result of lambda-abstraction:  $\lambda x (\neg \exists x)$ , denoting the property of there being no thing. This amounts to claiming that ‘I see nothing’, in the commonplace interpretation where I am not blind, in fact means that there is no thing having the property that I can see it when I want to see it.

9. I say ‘reprise pronouns’ rather than ‘resumptive pronouns’ because the latter ought probably to be kept in stock for cases where the pronoun is syntactically linked with its antecedent through a UDC, which is not the case here.

10. The syntactic structure of the relevant part of (25’) is presumably [<sub>VP</sub> *serka l* [<sub>S</sub> *pa panya e*]], where the first maximal projection dominating the pronoun (VP) dominates the gap.

11. ‘Fully’ insofar as the reference of the pronoun following *serka* is entirely determined at the moment that it is uttered. Also note this example which further supports the present analysis: *n na serka u toki n panya* / I chase you until I catch/ ‘I’ll chase you until I catch (you)’ (HGCS).

12. English topicalized constructions show the reverse pattern of grammaticality (‘The monkey, I chased, to catch it’ vs. \*‘The monkey, I chased it, to catch’), which is expected since they are UDCs — and confirms that (23) is not one. Something like the Kriyol pattern appears, it seems to me, in the following contrast:

- (i) I’m looking for a monkey so I can chase it
- (ii) \*I’m looking for it so I can chase a monkey

Since the NP and the pronoun do not share the same syntactic domain (or governing category), nothing should prevent ‘it’ from referring to ‘a monkey’ (compare ‘When I saw it, I knew it was a monkey’). The reason for the ungrammaticality of (ii) is then not a question of binding, but rather of the semantic dependence of one proposition on the other as in (23).

13. Actually, this is only one of the possible implications. Another is that, of all the things he might have bought, only the one he bought has the property of being a black horse. Still another, that, of all the black things he might have bought, only the one he bought has the property of being a horse. Intonation will often act as a disambiguating device in English, but not in many other languages, including Kriyol.

14. Because focalization is more common in Kriyol than it is in English, the English glosses below will often be unidiomatic or even ungrammatical. Rendering the Kriyol as exactly as possible was deemed more important than not offending English grammar.

15. NPs interpreted as predicates are a commonplace occurrence. Witness so-called 'elliptic' utterances like, e.g., 'An NP' as an answer to 'What is this?'. In a sense, (26) is indeed an elliptic sentence.

16. For instance, it does not agree with what could be taken to be its subject: *eu é que me enganei* /I is that me deceive-PAST-1SG/ 'It's me who was wrong' (Teyssier 1976:194).

17. Other Q-words or expressions not shown here are *kal ora ku* 'when', *kwandu ku* 'when', *pabya di ke ku* 'why' (lit. 'because of what that'), *ke ku manda ku* (lit. 'what (is it) that makes that'). *Kin* 'who' has a commitative form *bakin* meaning that the asker believes the persons about whom s/he is inquiring to be several and acting as a group (see Chapter 4). Interestingly, although Spanish has a functionally similar item (*quienes*), Portuguese does not seem to have ever possessed anything of the sort. Only direct questions are discussed below. Indeed, indirect questions need no special treatment in Kriyol as they are nothing but embedded direct questions without any syntactic reshuffling (that is to say, all examples of direct questions given below could be turned into indirect questions by simply adding, e.g., *n ka sibi* 'I don't know' in front).

18. By 'argumental position' I mean the syntactic position where phrase structure rules (or any other device) would locate a term given its grammatical function.

19. Even in the Past and the Future, *un son (i) yera (ba) kantu* 'How much was one?' *un son (i) na sedu kantu* are definitely better than *kantu ku un son (i) yera (ba)* and *kantu ku un son (i) na sedu*. That this not linked to *kantu* as such but to the expression meaning 'be how much' (in the sense of 'cost' or of 'be in a certain quantity') is shown by (46). Also note *es i libru di kin* /this it book of who/ 'Whose book is this?'. There is no other way to construct this question.

20. Except that Portuguese accepts all three possibilities, viz. simple fronting (*Que viste?*), focalization (*Que é que viste?*), and Q-in-situ (*Viste o quê?*), all meaning 'What did you see?' with different stylistic shades.

21. There are languages where the semantic make-up of Q-words is transparent, e.g. Haitian *kimoun* /?-person/ 'who', *kisa* /?-that/ 'what', *kile* /?-time/ 'when', etc.

22. *i kin ku fala u sin* is indeed a perfectly good, albeit uncommon, variant. In languages like English, one may surmise that the operator and the variable are obligatorily lexically conflated so that 'who', 'what', etc. are ordinary NPs in morphosyntax, even though they partake of the same semantic analysis as do Kriyol *kin*, *ke*, etc.

23. Sentences like *es i kin* do not have to be excepted from this statement since the Q-word they contain is not in the position of an argument, but of a predicate head.

24. This seems to imply that, in 'free' languages like Portuguese or French, the interfacing of semantics with syntax is simply undetermined in this domain. Any one will do, and only intonation is left to distinguish echo from non-echo in situ questions. In English, as already suggested, it is predetermined, but not in the form of total homomorphism.

25. Given the murkiness of the evidence (see above), I will in fact assume that *\*es minjer n tisi* is not a good sentence.

26. The value is implied by the [+R] feature and the FCR [+R] ⇒ [CFORM ku].



27. See (44) vs. (45). Parallel with *ke ku bu suta l kel* vs. *ku ke ku bu suta l* 'What did you hit him/her with?' (see above), one finds (i) *kil manduku ku n suta l kel* or (ii) *ku kil manduku ku n suta l* (\*kel) 'It's with that club that I hit him/her'.
28. Compare *kil omi i karpinteru ba* 'That man was a carpenter' vs. \**kil omi ba i karpinteru*.
29. Naturally, an appropriate context and the use of rigid designators may bring this meaning to the fore, as in 'Who was Napoleon before he became emperor?' — Answer: 'He was Bonaparte'.
30. \**Kil omi la ba* is excluded due to semantic incompatibility, since *kil... la*, being only deictic (whereas *kil* can be anaphoric — see Chapter 4), implies that the object is perceptually available.
31. For some reason, only *kin* 'who' is really possible. Proposals like ?*kil kusa ba i ke* 'What was that thing?' or ?*kil kasa ba i nunde* 'Where was that house [now destroyed]?' cause only bewilderment or rejection. Possible alternatives are *kil kusa i yera (ba) ke* and *nunde ku kil kasa sta ba (nel)* respectively.
32. Not in Portuguese though: *parece que ele seja um bom rapaz* 'It seems he is a good boy' or *ele parece ser um bom rapaz* 'He seems to be a good boy'. Although historically related, Kriyol *parsi* 'seem' (P. *parecer*) should not be confounded with *parsi* 'look like, resemble' (P. *parecer-se*), as in *i ta parsi ku si pape* /s/he A resemble with her/his father/ 'S/he looks like her/his father'.
33. As to why must *x* be indefinite, this is a point no theory I know of has yet made really clear. I may have to do with the enhanced agentivity of definite entities, so that (come a delegation) may be viewed as a self-contained event, whereas 'The delegation came' must be construed as (also) an activity of the said delegation. Tense/Aspect is relevant as well.
34. This is admittedly not very far from the standard transformationalist treatment of unaccusative predicates and 'inversion' constructions. See however Chomsky's (1991) account of raising verbs and 'it' insertion which, despite its rather different theoretical outlook, strikes me as very compatible with the present one.

## Chapter 7

1. Other verbs like *pirdi* are *kebra* 'break' (*kopu kebra* 'the glass broke'), *firbi* 'boil' (*yagu firbi* 'the water boiled'), *pega* 'catch' (*fugu pega* 'the fire caught'), *kaba* 'end' (*storya kaba* 'the story ended'), and probably others, none of which can be used transitively contrary to their Portuguese etyma (see, e.g., *acabar* 'terminate, end').
2. The interfacing can be viewed as a graphic rendering of the notion of top logical subject suppression (see Bresnan & Kanerva 1989; Grimshaw 1990).
3. In Portuguese, only (11) (*dinheiro foi-lhe emprestado*) is possible, and (12) (\**ele foi emprestado dinheiro*) is unthinkable. Unfortunately, I couldn't ascertain the state of the substrate languages in this respect due to the lack of detailed enough syntactic studies.
4. Although I didn't test it, I'm ready to wager that *kil banadera pudu mesinyu nel* is OK as well. I wouldn't be so affirmative with ?*ke ku kil dinyeru ta fasidu*, however.
5. Portuguese does not practice such reanalysis, but neither does it allow 'passive spreading'. Hence the translation of (17): *O senhor Cornebife foi mandado chamar*.

6. Such different implicatures are notoriously standard in languages having both CVs and CCs (see Comrie 1985).

7. Portuguese *mandar* has the same range of meanings. Interestingly, it also carries the same implicature, so that *a mãe mandou sair os meninos/ o carro* does not imply that the children or the car finally went out, or that the expressed causer was the ultimate one, any more than the Kriyol equivalent does. For the constructional difference, see below.

8. I use a singular pronoun so the Nominative-Accusative contrast can be seen. Note that **mame manda mininu pa i say** is a perfectly good sentence, but one that unequivocally means, 'The mother ordered the child to go out'. The object status of the causee is still verified when it refers to a non human entity that is not directly acted upon, so that the pronoun in **mame manda I say** could denote a car, for example.

9. This means it is not necessary to analyse such structures as instances of control, at least in the GB interpretation of the concept, since there is no autonomous, empty subject of the infinitive (PRO) whose coreferentiality with a higher subject is a matter for computation.

10. As it appears, **manda** may keep a direct object even when the lower verb also has one, whereas in Portuguese (or in French) in such a case that object would have to show up as an indirect object or a *by*-phrase (*mandaram estudar aquilo a João* 'they made John study that', *mandaram chamar o Sr Cornebife por alguém* 'they made somebody call Mr Corned-Beef' — see Cuesta & Da Luz 1971:519-520; also Rouveret & Vergnaud 1980; Zubizarreta 1985). This type of construction seems to be marginally possible in Kriyol (e **manda coma nyu Kornobif pa un algin** as an alternative to e **manda un algin coma nyu K.**). However, it is never obligatory, and it smacks of decreolization.

11. In English, it is certainly easier to say something like 'The mother is making the children go out, but they won't' than 'The mother made the children go out, but they wouldn't'. The latter does not seem to me to be utterly impossible, however.

12. So is of course, perhaps not for syntactic reasons, **\*i ka anos ku puy Ze Ze pirdi kurida**.

13. Semantics being viewed as an autonomous module interfaced with syntax and morphology, as in the Autolexical framework.

14. Although expressions such as *pôr água a aquecer* 'heat water', *pôr carne a assar* 'roast meat', etc. show that *pôr* has indeed quasi causative uses. Also see such expressions as *Puseram-me a fazer este trabalho horrível* 'They put me to doing this horrible job'.

15. As will become clear in the following, it is mainly the semantic correlates of unaccusativity that interest me, so no use will be made of the distinction between so-called 'deep' and 'surface' unaccusativity (for which see, e.g., Bresnan & Zaenen 1990).

16. No CV can be derived from the transitive use of **pirdi** evidenced in, e.g., **n pirdi kurida** 'I lost the race'. As a result, 'You made me lose the race' cannot be expressed as **\*bu pirdinti n kurida**, but only with a CC, **bu puy n (n) pirdi kurida**, as illustrated above.

17. Government is preferred to c-command as the relevant relation because, to the difference of the latter, it is not a purely configurational relation, but it depends on the identity of the elements, some of which can govern (e.g. operators), some of which cannot. With c-command one could equally well say that F2 c-commands O2 in (28).

18. The phonological alternations described above make it indisputable that [-nt/dV] must be analysed as a suffix rather than a postclitic.
19. 'Run' is generally taken to be unergative, and is shown to be so by the current syntactic tests (e.g. French *J'ai couru* with *avoir* instead of *être*). But consider that 'I ran home' may be synonymous with 'I came home', except for the Manner, which is not relevant, it seems, as far as unaccusativity is concerned (cf. French *Je suis venu à la maison en courant* — and *?Je suis couru à la maison* is a 'mistake' one hears often enough).
20. Along with syntactic tests, such as the auxiliary alternation of Italian, which are not available in all languages.
21. In Kantian terminology, unaccusativity is an analytical statement, whereas uncooperativeness is a synthetic one.
22. Note that this factor cannot be the sole explanator. There are two more I can discern. One is phonological: only verbs ending with a vowel can causativize. This excludes a small group of verbs ending with [y] or [n], even though some of them would semantically qualify (e.g. *kay* 'fall', *bin* 'come', etc.). The other factor is redundancy. For example, given the implications of CVs, *\*murinti* 'make die' would be totally redundant with *mata* 'kill' in a way that 'make die' and 'kill' are not.
23. Provided one makes room for metaphor, inanimate subjects of transitive verbs (e.g. "Revolution changed our lives", "The stone hit the man", etc.) should not be a problem.
24. Wolof is interesting in this respect, as it has two causative suffixes, [al] and [loo], the difference between which is described by Church as follows (1981:210, my translation), "With *E al*, the object, be it personal or non personal, is essentially a passive receptor; with *-loo*, the object is influenced in such a way that it becomes the subject of the action: you straighten (*jubal*) a child with a stick, but you straighten (*jubloo*) him or her through advising." Wolof [al] appears thus quite similar to Kriyol [nt/dV].
25. A similar, albeit rather more limited, use of Meaning Postulates may be found in the Functional Grammar framework (see Dik 1978, Siewierka 1991); also see Bernth & Lappin (1991). Again, the original formulation is Carnap (1947:222-226).
26. At least some of them, viz. those that can be noted as MPs. Meaningful expression (not necessarily obvious) also depends from a host of unconscious (as distinct from preconscious) informations. This is probably a rather different issue, however.
27. This restriction against iterated derivation is surely not a universal, hence its significance.

## Chapter 8

1. The 'counter-cultural' movement of the early 70s was very active in promoting this renewal of comic-book art. It was an important factor in the United States as well — witness the works of Crumb, to cite only one — except that it does not seem to have planted such deep and lasting roots in the American cultural scene as it did in the European one, probably because the American intellectuals never took comic-books really seriously (to the possible exception of Art Spiegelman's magnificent *Maus*, he also being an heir of the counter-culture).

2. Literally, **nkurbadu** means 'curved, warped'. Here, it qualifies persons whose wickedness puts them beyond all hopes of reformation.
3. There is probably an ethnic joke here, coming from non-Muslims, and directed toward Muslims who are supposed not to consume alcoholic drinks and for whom tea is a quasi sacred beverage. I will come back to these religious overtones.
4. *Finadu* seems to imply a pun on Portuguese *finado*, meaning 'defunct', and *afinado* meaning 'refined', but also 'laughed at'.
5. I do not know whether our authors ever considered making films. It could only have been a dream in any event.
6. I am referring to syntactic devices such as multiple embedding or passives with agents, which Kriyol has potentially but does not use, or to stylistic devices such as quasi-direct discourse (on which see Kuroda 1973; Banfield 1978).



## References

- Abney, S. (1987) "The English Noun Phrase in its Sentential Aspect". PhD Dissertation, MIT.
- Alleyne, M. C. (1980) *Comparative Afro-American*. Ann Arbor: Karoma
- Abourizk, M. (1991) "Le créole anglais de Gambie (aku)". Thèse de doctorat, Université Paris III.
- Albuquerque, L. de (1991) *O confronto do olhar: o encontro dos povos na época das navegações portuguesas*. Lisboa: Caminho.
- Almada, M.D. de Oliveira (1961) *Cabo Verde: Contribuição para o estudo do dialecto falado no seu arquipélago*. Lisboa: Junta de Investigação do Ultramar.
- Anderson, S. & P. Kiparsky (eds) (1973) *A Festschrift for Morris Halle*. New York: Holt, Rinehart & Wilson.
- Andrade, E. d', A. Gomes & I. Teixeira (1992) "Observações sobre o sistema acentual do crioulo da Guiné-Bissau (CGB)", pp. 135-140 in E. d'Andrade & A. Kihm (eds).
- Andrade, E. d', & A. Kihm (eds) (1992) *Actas do Colóquio sobre 'Crioulos de base lexical portuguesa'*. Lisboa: Edições Colibri.
- Andrzejewski, B.W., S. Pilaszewicz & W. Tyloch (eds) (1985) *Literatures in African Languages: Theoretical Issues and Sample Surveys*. Warszawa: Wiedza Powszechna/ Cambridge: Cambridge University Press.
- Arendt, H. (1979) *The Origin of Totalitarianism*. New York: Harcourt, Brace & Jovanovitch.
- Bach, E. & R.T. Harns (eds) (1968) *Universals in Linguistic Theory*. New York: Holt, Rinehart and Winston.
- Baker, M.C. (1988) *Incorporation: A Theory of Grammatical Function Changing*. Chicago: University of Chicago Press.
- Banfield, A. (1978) "Where epistemology, style, and grammar meet literary history: The development of represented speech and thought", *New Literary History* 9, 415-454.
- Barlow, M., D. Flickinger, & M. Westcoat (eds) (1983) *Proceedings of the second West Coast Conference on Formal Linguistics*. Stanford: Stanford Linguistics Department.
- Barros, M. Marques de (1882) "Guiné portuguesa ou breve notícia sobre alguns dos seus usos, costumes, línguas e origem dos seus povos", *Boletim da Sociedade de Geografia de Lisboa* 12, 707-731.
- Barwise, J. & J. Perry (1983) *Situations and Attitudes*. Cambridge (MA): MIT Press.
- Bentolilla, A. et al. (1976) *Dictionnaire haïtien-français*. Paris: Editions caribéennes.
- Benveniste, E. (1966) *Problèmes de linguistique générale*. Paris: Gallimard.
- Bernabé, J. (1983) *Fondal-natal: grammaire basilectale approchée des créoles guadeloupéen et martiniquais*. Paris: L'Harmattan.

- Bernth, A. & S. Lappin (1991). "A meaning postulate based inference system for natural language", IBM Research Report RC 16947.
- Bickerton, D. (1975) *Dynamics of a Creole System*. Cambridge: Cambridge University Press.
- Bickerton, D. (1981) *Roots of Language*. Ann Arbor: Karoma.
- Bocandé, B. (1849) "De la langue créole de la Guinée portugaise (notes sur la Guinée portugaise ou Sénégalaise méridionale)", *Bulletin de la Société de Géographie* (Paris) 12, 73-77.
- Boretzky, N. (1983) *Kreolsprachen, Substrate und Sprachwandel*. Wiesbaden: Harrassowitz.
- Boretzky, N., W. Enninger, & T. Stolz (eds) (1988) *Beiträge zum 4. Essener Kolloquium über Sprachwandel, Sprachkontakt, Sprachwechsel, Sprachtod*. Bochum: Brockmeyer.
- Borsley, R.D. (1989) "Phrase structure grammar and the *Barriers* conception of phrase structure", *Linguistics* 27, 843-863.
- Borsley, R.D. (1991) *Syntactic Theory: A Unified Approach*. London: Edward Arnold.
- Bouchard, D. (1984) *On the Content of Empty Categories*. Dordrecht: Foris.
- Bourdieu, P. (1982) *Ce que parler veut dire: l'économie des échanges linguistiques*. Paris: Fayard.
- Boxer, C. R. (1969) *The Portuguese Seaborne Empire: 1415-1825*. London: Hutchinson.
- Bresnan, J. & A. Zaenen (1990) "Deep unaccusativity in LFG", pp. 45-57 in K. Dziwirek, P. Farrell & E. Mejias-Bikandi (eds).
- Bresnan, J. & J. Kanerva (1989) "Locative inversion in Chichewa: A case study of factorization in grammar", *Linguistic Inquiry* 20, 1-50.
- Buis, P. (1990) *Essai sur la langue manjako de la zone de Bassarel*. Bissau: INEP.
- Burzio, L. (1986) *Italian Syntax: A Government-Binding Approach*. Dordrecht: Reidel.
- Byrne, F. (1987) *Grammatical Relations in a Radical Creole*. Amsterdam: Benjamins.
- Carnap, R. (1947). *Meaning and Necessity: A Study in Semantics and Modal Logic*. Chicago: University of Chicago Press
- Carden, G. (1976) *English Quantifiers: Logical Structure and Linguistic*. New York: Academic Press.
- Chataignier, A. (1963) "Le créole portugais du Sénégal: observations et textes", *Journal of African Languages* 2, 44-71.
- Chomsky, N. (1970) "Remarks on nominalization", pp. 184-221 in R. Jacobs & P. Rosenbaum (eds).
- Chomsky, N. (1980) *Rules and Representations*. New York: Columbia University Press.
- Chomsky, N. (1981) *Lectures on Government and Binding*. Dordrecht: Foris.
- Chomsky, N. (1982) *Some Concepts and Consequences of a Theory of Government and Binding*. Cambridge (MA): MIT Press.
- Chomsky, N. (1985) *Knowledge of Language*. New York: Praeger.
- Chomsky, N. (1986) *Barriers*. Cambridge (MA): MIT Press.
- Chomsky, N. (1991) A minimalist program for linguistic theory. MS.

- Church, E. (1981) *Le système verbal du wolof*. Dakar: Université de Dakar.
- Cinque, G. (1990). *Types of A-Dependencies*. Cambridge (MA): MIT Press.
- Clements, J.C. (1992) "Foreigner talk and the origins of Pidgin Portuguese", *Journal of Pidgin and Creole Languages* 7, 75-92.
- Comrie, B. (1976) *Aspect*. Cambridge: Cambridge University Press.
- Comrie, B. (1985) "Causative verb formation and other verb-deriving morphology", pp. 309-348 in T. Shopen (ed), vol. III.
- Corêa, M.L. Monteiro Sales (1985) *O tempo nos verbos portugueses: uma introdução à sua interpretação semântica*. Brasília: Thesaurus.
- Couto, H. Honório do (1992) "Lançados, grumetes e a origem do crioulo português noroeste africano", pp. 109-122 in E. d'Andrade & A. Kihm (eds).
- Cuesta, P.V. & M. A. Mendes Da Luz (1971) *Gramática da língua portuguesa*. Lisboa: Edições 70.
- Cunha, C. & L. Cintra (1987) *Nova gramática do português contemporâneo*. Lisboa: Edições João Sá da Costa.
- Dalgado, S.R. (1900) *Dialecto indo-português de Ceylão*. Lisboa: Imprensa nacional.
- Damoiseau, R. (1982) *Etudes de syntaxe comparée: créole haïtien - créole martiniquais*. Centre de Linguistique, Université d'Etat d'Haïti.
- DeCamp, D. (1974) "Neutralization, iteratives, and ideophones: The locus of language in Jamaica", pp. 46-60 in D. DeCamp & I.F. Hancock (eds).
- DeCamp, D. & I.F. Hancock (eds) (1974) *Pidgins and Creoles: Current Trends and Prospects*. Washington, DC: Georgetown University Press.
- Dik, S.C. (1978) *Functional Grammar*. London: Academic Press.
- Doneux, J.-L. & J.-L. Rougé (1988) *En apprenant le kriol à Ziguinchor et à Bissau*. Paris: L'Harmattan.
- Doneux, J.-L. (1967) "Le manjaku: classes nominales et questions sur l'alternance consonantique", *La classification nominale dans les langues négro-africaines*. Paris: Editions du CNRS, 261-276.
- Dowty, D. et al. (1981) *Introduction to Montague Semantics*. Dordrecht: Foris.
- Dumont, P. (1983) *Le français et les langues africaines au Sénégal*. Paris: ACCT-Karthala.
- Dziwirek, K., P. Farrell & E. Mejias-Bikandi (eds) (1990) *Grammatical Relations: A Cross-Theoretical Perspective*. Stanford: CSLI.
- Emonds, J.E. (1985) *A Unified Theory of Syntactic Categories*. Dordrecht: Foris.
- Enç, M. (1987) "Anchoring conditions for tense", *Linguistic Inquiry* 18, 633-657.
- Ewen, C.J. (1982) "The internal structure of complex segments", pp. 27-67 in H. van der Hulst & N. Smith (eds).
- Fauconnier, G. (1984) *Espaces mentaux: Aspects de la construction du sens dans les langues naturelles*. Paris: Editions de Minuit.
- Feinstein, M.H. (1979) "Prenasalization and syllable structure", *Linguistic Inquiry* 10, 245-278.



- Ferraz, L.I. (1979) *The Creole of São Tomé*. Johannesburg: Witwatersrand University Press.
- Ferraz, L.I. & M.F. Valkhoff (1975) "A comparative study of São-Tomense and Cabo-verdiano creole", pp. 15-39 in M.F. Valkhoff (ed).
- Feyerabend, P. (1988) *Against Method* (revised edition). London: Verso.
- Fillmore, C.J. (1968) "The case for case", pp. 1-68 in E. Bach & R.T. Harms (eds).
- Forsyth, J. (1970) *A Grammar of Aspect: Usage and Meaning in the Russian Verb*. Cambridge: Cambridge University Press.
- Fradin, B. (1988) "Approche des constructions à détachement: la reprise interne", *Langue française* 78, 26-56.
- Gazdar, G. et al. (1985) *Generalized Phrase Structure Grammar*. London: Basil Blackwell.
- Goffman, E. (1981) *Forms of Talk*. Philadelphia: University of Pennsylvania Press.
- Goffman, E. (1986) The felicity condition, MS ["La condition de félicité", trad. A.Kihm, *Actes de la recherche en sciences sociales* 64 & 65, 63-78, 87-98.
- Goldsmith, J. & E. Woisetschlaeger (1982) "The logic of the English progressive", *Linguistic Inquiry* 13, 79-90.
- Gomes, A. & J.G. Mendonça (1981) *Essai de grammaire créole de Guinée-Bissau*. Bissau: Ministério da Educação.
- Goodman, M. (1987) "Pidgin origins reconsidered", *Journal of Pidgin and Creole Languages* 2, 149-162.
- Grimshaw, J. (1990) *Argument Structure*. Cambridge (MA): MIT Press.
- Hale, K. & P. Platero (1986) "Parts of speech", pp. 31-40 in P. Muysken & H. van Riemsdijk (eds).
- Hart, T.R. (1955) "Notes on sixteenth century Portuguese pronunciation", *Word* 11, 404-415.
- Hawkins, J.A. (1988) "Explaining language universals", pp. 3-28 in J.A. Hawkins (ed).
- Hawkins, J.A. (ed) (1988) *Explaining Language Universals*. London: Basil Blackwell.
- Holm, J. (1988) *Pidgin and Creole Languages*. Cambridge: Cambridge University Press.
- Hornstein, N. (1977) "Towards a theory of tense", *Linguistic Inquiry* 8, 521-558.
- Horta, J. da Silva (1991a) "A imagem do Africano pelos Portugueses antes do contacto", pp. 43-69 in L. de Albuquerque et al. (eds).
- Horta, J. da Silva (1991b) "Primeiros olhares sobre o Africano do Sara ocidental à Serra Leoa (meados do século XV-inícios do século XVI)" pp. 73-126 in L. de Albuquerque (ed).
- Hulst, H. van der & N. Smith (eds) (1982) *The Structure of Phonological Representations*. Dordrecht: Foris.
- Isacenko, A.V. (1962) *Die russische Sprache der Gegenwart, 1: Formenlehre*. Halle: Niemeyer.
- Jackendoff, R. (1983) *Semantics and Cognition*. Cambridge (Mass.): MIT Press.
- Jacobs, R. & P. Rosenbaum (eds) (1970) *Readings in English Transformational Grammar*. Waltham (Mass.): Ginn.

- Jaeggli, O. & C. Silva-Corvalan (eds) (1986) *Studies in Romance Linguistics*. Dordrecht: Foris.
- Jesus, M. de, J. Philipsen & S. Pieters (1978) *Papiamentu voor beginners*. Amsterdam: Antilliaans Contact Centrum.
- Johnson-Laird, P.N. (1983) *Mental Models*. Cambridge: Cambridge University Press.
- Karttunen, L. (1977) "The syntax and semantics of questions", *Linguistics and Philosophy* 1, 3-44.
- Kayne, R. (1984) *Connectedness and Binary Branching*. Dordrecht: Foris.
- Keenan, E.L. (1988) "On semantics and the binding theory", pp. 105-144 in J.A. Hawkins (ed).
- Kihm, A. (1980) Aspects d'une syntaxe historique: études sur le créole portugais de Guinée-Bissau. Thèse de 3<sup>e</sup> cycle, Université Paris III.
- Kihm, A. (1986) "Nasality in Kriol: the marked case?", *Journal of Pidgin and Creole Languages* 1, 81-107.
- Kihm, A. (1989) "Lexical conflation as a basis for relexification", *The Canadian Journal of Linguistics / Revue canadienne de linguistique* 36, 351-376.
- Kihm, A. (1990) "What is it that you said? A study of obligatory focalization in two creoles and beyond" *Conference on Focus and Grammatical Relations in Creole Languages*, Chicago, may 10-12, 1990.
- Kihm, A. (1991) "Les constructions focalisées en wolof: approche autolexicale d'une contradiction morpho-syntaxique", *Linguistique africaine* 7, 7-32.
- Kihm, A. (1992a) "Causative constructions in Kriyol: A semantic approach", GLOW Conference, Lisbon, April 1992.
- Kihm, A. (1992b) "Lingua de preto texts as an early and reliable source for Creole Portuguese", paper presented at the Conference on Early Sources for Creole Languages, Amsterdam, September 1992.
- Kihm, A. (1993) Parallèles et croisements: essais de créolistique et de grammaire pluridimensionnelle. Thèse d'habilitation, Université Paris VII.
- Kihm, A. & A. Gomes (1988) "Quelques points de syntaxe du manjaku", *Langues et grammaires* 1, 21-56.
- Kihm, A. & B. Laks (1989) "De l'accent en kriyol", *Linx* 20, 89-111.
- Kihm, A. & J.-L. Rougé (1988) "Les trois irrécupérables" de Fernando Julio: édition critique d'une bande dessinée en kriol (Guinée-Bissau)", *Les Cahiers du LACITO* 3, 107-177.
- Kirschner, C. & J. DeCesaris (eds) (1989) *Studies in Romance Linguistics*. Amsterdam: Benjamins.
- König, E. (1988) "Concessive connectives and concessive sentences: cross-linguistic regularities and pragmatic principles", pp. 145-166 in J.A. Hawkins (ed).
- Kornai, A. & G.K. Pullum (1990) "The X-bar theory of phrase structure", *Language* 66, 24-50.

- Kouwenberg, S. & I.E. Robertson (1988) "The marking of tense, mood, and aspect in the Berbice Dutch Creole language", pp. 151-174 in N. Boretzky, W. Enninger & T. Stolz (eds).
- Kuroda, S.Y. (1973) "Where epistemology, grammar, and style meet: A case study from Japanese", pp. 377-391 in S. Anderson & P. Kiparsky (eds).
- Labov, W. (1968) *Sociolinguistic Patterns*. Philadelphia: University of Pennsylvania Press.
- Landman, F. (1992) "The progressive", *Natural Language Semantics* 1, 1-32.
- Langacker, R.W. (1987) *Foundations of Cognitive Grammar, vol. 1: Theoretical Prerequisites*. Stanford: Stanford University Press.
- Lefebvre, Claire. (1990) "On the Interpretation of Predicate Cleft." *Linguistic Review* 6: 169-194.
- Lefebvre, C. and D. Massam (1988) "Haitian Creole syntax: a case for DET as head", *Journal of Pidgin and Creole Languages* 3, 213-243.
- Lefebvre, C. & P. Muysken (1988) *Mixed Categories: Nominalizations in Quechua*. Dordrecht: Reidel.
- Lumsden, J. (1989) "On the distribution of determiners in Haitian Creole" *Revue québécoise de linguistique* 18, 65-94.
- Marantz, A. (1984) *On the Nature of Grammatical Relations*. Cambridge (Mass.): MIT Press.
- Matthews, P.H. (1974) *Morphology: An Introduction to the Theory of Word-Structure*. Cambridge: Cambridge University Press.
- Mboj, C. (1979) *La phonologie du créole de Guinée-Bissau*. Dakar: CLAD.
- McCawley, J.D. (1981) *Everything That Linguists Have Always Wanted to Know about Logic But Were Afraid to Ask*. Chicago: Chicago University Press.
- McClure, W. (1990) "A lexical semantic explanation for unaccusative mismatches", pp. 305-318 in K. Dziwirek, P. Farrell & E. Mejias-Bikandi (eds).
- Medeiros, F. de (1985) *L'Occident et l'Afrique (XIIIe-XVe siècle)*. Paris: Karthala.
- Meintel, D. (1975) "The creole dialect of the island of Brava" pp. 205-256 in M. Valkhoff (ed).
- Meintel, D. (1984) *Race, Culture, and Portuguese Colonialism in Cabo Verde*. Syracuse (NY): Maxwell School of Citizenship and Public Affairs.
- Milner, J.-C. (1978) *De la syntaxe à l'interprétation*. Paris: Le Seuil.
- Montague, R. (1974) *Formal Philosophy*. New Haven: Yale University Press.
- Montenegro, T. 1990 *Proverbios crioulos: a arquitetura das imagens*. Bissau: INEP
- Montenegro, T. & C. de Moraes (1979) *Junbai: stórias de Bolama e do outro mundo*. Bolama: Imprensa nacional.
- Mota, A. Teixeira da (1946) "A descoberta da Guiné", *Boletim cultural da Guiné portuguesa* I(1), 11-68; (2), 273-326; (3), 457-509.
- Muysken, P. (1981) "Creole tense/mood/aspect systems: the unmarked case?", pp. 181-199 in P. Muysken (ed).
- Muysken, P. (ed) (1981) *Generative Studies on Creole Languages*. Dordrecht: Foris.

- Muysken, P. & H. van Riemsdijk (eds) (1986) *Features and Projections*. Dordrecht: Foris.
- N'Diaye-Correard, G. (1970) *Etudes fca ou balante (dialecte ganja)*. Paris: SELAF.
- Naro, A.J. (1978) "A study on the origins of pidginization", *Language* 54, 314-347.
- Neto, S. da Silva (1988) *História da língua portuguesa* (5° ed.). Rio de Janeiro: Presença.
- Njie, C.M. (1982) *Description syntaxique du wolof de Gambie*. Dakar: NEA.
- Noonan, M. (1985) "Complementation", pp. 42-140 in T. Shopen (ed), Vol. 2.
- PAIGC (1974) *História da Guiné e ilhas de Cabo Verde*. Porto: Afrontamento
- Perlmutter, D.M. (ed) (1983) *Studies in Relational Grammar 1*. Chicago: University of Chicago Press.
- Perlmutter, D.M. & P.M. Postal (1984) "Impersonal passives and some relational laws", in D.M. Perlmutter & C.G. Rosen (eds).
- Perlmutter, D.M. & C.G. Rosen (eds) (1984) *Studies in Relational Grammar 2*. Chicago: The University of Chicago Press.
- Picallo, M. C. (1984) "The INFL Node and the Null Subject Parameter." *Linguistic Inquiry* 15.1: 75-102.
- Pilaszewicz, S. (1985) "The rise of written literatures in African languages", pp. 49-71 in B.W. Andrzejewski, S. Pilaszewicz & W. Tyloch (eds).
- Pinto-Bull, B. (1989) *O crioulo de Guiné-Bissau: filosofia e sabedoria*. Bissau: INEP.
- Pollard, C. & I.A. Sag (1983) "Reflexives and reciprocals in English: an alternative to the binding theory", pp. 189-183 in M. Barlow, D. Flickinger, & M. Wescot (eds).
- Pollard, C. & I.A. Sag (1987) *Information Based Syntax and Semantics, vol. 1*. Stanford: CSLI.
- Pollock, J.-Y. (1983) "Sur quelques propriétés des phrases copulatives en français", *Langue française* 58, 89-125.
- Pollock, J.-Y. (1989) "Verb movement, universal grammar, and the structure of IP", *Linguistic Inquiry* 20, 365-424.
- Raposo, E. (1986) "On the null object in European Portuguese", pp. 373-390 in O. Jaeggli & C. Silva-Corvalan (eds).
- Reichenbach, H. (1947) *Elements of Symbolic Logic*. New York: Free Press.
- Reinhardt, T. (1986) "Principes de perception des formes et organisation temporelle des textes narratifs", *Recherches linguistiques de Vincennes* 14-15, 45-92.
- Rizzi, L. (1986) "Null objects in Italian and the theory of pro", *Linguistic Inquiry* 17, 501-557.
- Rougé, J.-L. (1986) "Uma hipótese sobre a formação do crioulo da Guiné-Bissau e da Casamansa", *Soronda* 2, 28-49.
- Rougé, J.-L. (1988) *Petit dictionnaire étymologique du kriol de Guinée-Bissau et Casamance*. Bissau: INEP.
- Rouveret, A. & J.-R. Vergnaud (1980) "Specifying reference to the subject: French causatives and conditions on representations", *Linguistic Inquiry* 11, 97-202.
- Rowlands, E.C. (1959) *A Grammar of Gambian Mandinka*. London: SOAS.
- Ruwet, N. (1982) *Grammaire des insultes et autres études*. Paris: Le Seuil.

- Ruwet, N. (1986) "On weather verbs", *Proceedings of the Chicago Linguistic Society* 22, 195-215.
- Ruwet, N. (1989) "Weather verbs and the unaccusative hypothesis", pp. 313-345 in C. Kirschner & J. DeCesaris (eds).
- Sadock, J.M. (1985) "Autolexical syntax: a theory of noun incorporation and similar phenomena", *Natural Language and Linguistic Theory* 3, 379-440.
- Sadock, J.M. (1990) "Review of Mark C. Baker, Incorporation", *Natural Language and Linguistic Theory* 8, 129-141.
- Sadock, J.M. (1991a) *Autolexical Syntax: A Theory of Parallel Grammatical Representations*. Chicago: University of Chicago Press.
- Sadock, J.M. (1991b) "Yiddish as an Athapaskan language". MS.
- Sag, I.A. (1987) "Grammatical hierarchy and linear precedence", pp. 304-340 in G.J. Huck & A.E. Ojeda (eds).
- Said-Ali, M. (1971) *Gramática histórica da língua portuguesa*. Rio de Janeiro: Livraria Acadêmica.
- Sapir, D.J. (1969) *A Grammar of Dyola-Fogny: A Language Spoken in the Basse-Casamance Region of Senegal*. Cambridge: Cambridge University Press.
- Sauvageot, S. (1965) *Description synchronique d'un dialecte wolof: le parler du Dyolof*. Dakar: IFAN.
- Schuchardt, H. (1888) "Beiträge zur Kenntnis des kreolischen Romanisch II: Zum Negerportugiesischen Senegambiens", *Zeitschrift für romanische Philologie* 12, 301-322.
- Schuchardt, H. (1893) "Die mehrzielige Frage- und Relativsatz", *Analecta Graeciensia*, 195-217.
- Sebba, M. (1986) "Adjectives and copulas in Sranan Tongo", *Journal of Pidgin and Creole Languages* 1, 109-121.
- Sells, P. (1985) *Lectures on Contemporary Syntactic Theories: An Introduction to Government-Binding Theory, Generalized Phrase Structure Grammar, and Lexical-Functional Grammar*. Stanford: CSLI.
- Seuren, P.A.M. (1986) "Adjectives as adjectives in Sranan: a reply to Sebba", *Journal of Pidgin and Creole Languages* 1, 123-134.
- Shieber, S. (1987) *An Introduction to Unification-Based Approaches to Grammar*. Stanford: CSLI
- Shopen, T. (ed) (1985) *Language Typology and Syntactic Description*. Cambridge: Cambridge University Press.
- Siewierska, A. (1991) *Functional Grammar*. London: Routledge.
- Silva, M. da Graça Garcia Nolasco da (1970) "Subsídios para o estudo dos 'lançados' na Guiné", *Boletim cultural da Guiné portuguesa* 25(97), 25-40; (98), 217-232; (99), 397-420; (100), 513-560.
- Sportiche, D. (1988) "A theory of floating quantifiers and its corollaries for constituent structure", *Linguistic Inquiry* 19, 425-449.

- Talmy, L. (1988). "Force Dynamics in Language and Thought." *Cognitive Science* 12: 12-100.
- Talmy, L. (1985) "Lexicalization patterns: semantic structure in lexical forms", pp. 57-149 in T. Shopen (ed).
- Teyssier, P. (1959) *La langue de Gil Vicente*. Paris: Klincksieck.
- Teyssier, P. (1976) *Manuel de langue portugaise: Portugal-Brésil*. Paris: Klincksieck.
- Teyssier, P. (1980) *Histoire de la langue portugaise*. Paris: PUF.
- Thomaz, L.F. (1989) *Le Portugal et l'Afrique au XVe siècle: les débuts de l'expansion*. Lisboa: Instituto de Investigação científica tropical.
- Todd, L. (1984) *Modern Englishes: Pidgins and Creoles*. Oxford: Basil Blackwell.
- Valdman, A. (1978) *Le créole: structure, statut, origine*. Paris: Klincksieck.
- Valkhoff, M. (ed) (1975) *Miscelânea luso-africana*. Lisboa: Junta de Investigações científicas do Ultramar.
- Veiga, M. (1984) *Diskrison strutural di lingua kabuverdianu*. Praia: Institutu kabuverdianu di Livru.
- Weinrich, H. (1971) *Tempus, besprochene und erzählte Welt*. Stuttgart.
- Welmers, W. (1973) *African Language Structures*. Berkeley: University of California Press.
- Williams, E. (1981) "On the notions 'lexically related' and 'head of a word'", *Linguistic Inquiry* 2, 245-274.
- Wilson, W.A.A. (1959) "Uma volta linguística na Guiné", *Boletim cultural da Guiné portuguesa* 14(56), 569-601.
- Wilson, W.A.A. (1961) "Outline of the Balanta language", *African Language Studies* 2. London: SOAS.
- Wilson, W.A.A. (1962) *The Crioulo of Guiné*. Johannesburg: Witwatersrand University Press.
- Wurm, S.A. & P. Mühlhäusler (1985) *Handbook of Tok Pisin (New Guinea Pidgin)*. Canberra: Pacific Linguistics.
- Zubizarreta, M.L. (1985) "The relation between morphophonology and morphosyntax: The case of Romance causatives", *Linguistic Inquiry* 16, 247-289.



# Index

## A

abstraction, 130, 131, 199, 203, 211, 290  
Accessibility Hierarchy, 246  
accessibility, interworld, 119  
Adverbs, 31, 32, 33, 40, 44, 51, 84, 98, 105, 106, 112, 115, 272, 287  
agreement, 41, 81, 83, 132, 133, 148, 149, 156, 162, 165, 171, 175, 176, 272, 295  
Aku (Gambian Creole English), 71  
anaphora, 88  
anterior, 99, 118, 119, 121, 191  
arguments, definition, 47, 55, 276  
Autolexical Syntax, 10, 56, 283  
auxiliary verbs, sequences of, 22, 32, 98

## B

background tense, 100, 103  
Balanta, 24, 47, 56, 86, 113, 129, 261, 269  
binding, 221, 226, 250, 284, 290

## C

clifting, 63, 227. *see* focalization  
clitics, 180, 235  
cognate object, 185  
COME vs. GO, temporal interpretation of, 116  
comic-books, 7, 12, 263, 265, 266, 267, 268, 294  
comitative, 151, 291  
complementizer, 27, 188, 192, 193, 194, 196, 197, 198, 199, 200, 201, 202, 207, 208, 229, 230, 234, 249, 286  
‘say’ as, 192  
compositionality, 101, 111  
compounds, 126, 127, 128, 273  
concessive, 183, 185, 204, 209, 286  
conditional sentences, 94, 110  
conflation, lexical, 24, 103, 113, 152, 210, 251, 273, 282  
control predicates, 27, 29, 31, 187, 210, 211, 212  
Copulative sentences, identificational vs. predicative, 37, 227  
counterfactuality, *see* conditional sentences, 94, 95, 102, 204

## D

decreolized varieties, 7, 149, 200, 244, 286  
definite vs. indefinite, 135, 137, 138, 139, 238, 274, 285, 292  
determiner, 19, 28, 43, 107, 125, 276, 281



Discoveries, 1  
 dislocated constructions, 38, 187, 217  
 Dyola, 71, 113, 129, 130

**E**

environmental verbs, 48, 49  
 ERS schema, 100, 102  
 event vs. non event, 89, 119, 278

**F**

finite vs non finite, 31, 36, 41, 45, 97, 112, 115, 121, 123, 125, 175, 177, 187, 189,  
 190, 194, 203, 204, 208, 210, 211, 212, 213, 214, 243, 247, 249, 251, 272, 279  
 finiteness, 86, 118, 121, 122, 171  
 focalization, 217, 220, 221, 224, 227, 228, 229, 230, 231, 232, 291  
 focus, 88, 134, 139, 151, 159, 272, 283  
 folktale, 265  
 free indirect discourse, 202, 203

**G**

gender, 126, 162  
 gerundive, 90, 187, 203, 204, 206, 210, 211, 212, 287, 288, 289  
 gerunds, 53. *see* (non) finite  
 Government and Binding (GB), 9  
*grumetes*, 4, 5

**H**

habitual, 91, 92, 93, 96, 278

**I**

Ideophones, 76, 105, 106, 274, 276, 277  
 imperative, 44, 45, 46, 81, 86  
 inchoative, 88, 89, 90, 278  
 incorporation, 83, 219, 274  
 individualization, 134  
 infinitive, inflected, 189, 190, 208, 250  
 injunctive, 45, 46  
 intersection, of lexemes, 57, 58, 63  
 interval, 38, 84, 88, 94, 99, 100, 102, 116, 117, 118, 119, 120, 121, 122, 279, 280  
 inversive prefix, 24  
 involved complements, 55

**K**

Kriyol  
 deep vs light, 8  
 dialects of, 5, 17, 19  
 history of, 3

old, 8  
 phonology, 12, 270

**L**

*lançados*, 4  
 Language Bioprogram Hypothesis (LBH), 11  
*língua de preto*, 3, 46  
*lingua kriston*, 2

**M**

Mandinka (Niger-Congo,Mande), 16, 37, 47, 79, 83, 90, 93, 128, 132, 139, 140, 142, 190, 192, 205, 210, 251, 272, 276, 279, 281, 287  
 Manjaku (Niger-Congo,Atlantic), 19, 24, 47, 56, 65, 66, 71, 86, 103, 113, 128, 129, 132, 140, 152, 168, 169, 214, 251, 261, 265, 269, 288, 289  
 markers, 34, 103  
 meaning postulates, 53, 190, 203, 236, 258, 287, 294  
 mental state verbs, 89, 92, 189, 278  
 Methodological anarchism, 10  
 mismatch, 56, 58, 60, 187, 222  
 modal verbs, 23, 26, 27, 28, 29, 67, 72, 271, 278, 287  
 morphology, inflectional, 83, 125, 131, 132

**N**

NEG-prop(agation), 170, 171, 172, 174, 285  
 new vs. presupposed, 135, 136, 137, 157  
 null subject, 46, 52, 152, 196, 219, 237, 282

**O**

obliqueness, 276  
 Obliqueness Hierarchy, 246  
 occasion, as specific state of affairs, 87, 88, 94, 176, 278  
 ordinals, 143, 282

**P**

PAIGC, 5, 6  
 parasitic gap, 227  
 perfective vs. imperfective, definition, 118, 278, 279  
 phonaesthetic adverbs, 76. *see* Ideophones  
 Phrase Structure Grammar, 291  
 pragmatic rules, 81  
 predicate clefts, 183  
 predicate, logical vs. syntactic, 23, 117  
 prepositions, 67, 68, 71, 126, 154, 177, 206, 207, 208, 235, 284  
 progressive, 87, 89, 92, 93, 100, 121, 248, 278

## pronouns

- argumental vs. non-argumental, 150, 154, 162, 282
  - case of, 126, 151
  - polite forms, 152, 281, 282
- prospective, 44, 88, 89, 108, 110, 113, 116, 117, 121

**Q**

- quantifier floating, 173, 215, 224, 282
- quantifier linking, 174

**R**

- reconnaissance language, 3
- reduplication, 24, 271
- relexification, 11
- resumptive, 180, 181, 182, 196, 217, 290

**S**

- sequence of tenses 202
- ser* vs. *estar*, Kriyol correspondent of contrast, 41, 96
- serial verbs, 195, 213, 287
- slaves, in 15th century Portugal, 3, 5, 269
- sociolinguistic, 5, 8, 13
- specific vs. non specific, definition, 87, 88, 89, 277, 289
- specifier, 43, 125, 165, 166, 180, 209, 281, 284, 285, 286
- subcategorization, 25, 32, 44, 57, 62, 63, 67, 76, 149, 175, 184, 224, 226, 276
- substrate languages, 32, 34, 41, 56, 90, 93, 102, 282, 292
- successivity, 109

**T**

- topicalization, 75, 217, 218, 219, 222, 224, 226, 230, 289, 290
- transitivity alternations, 65, 242

**U**

- unaccusative, 252, 292
- unaccusative vs. unergative, 26
- uncooperative subjects, 256, 258, 294
- underspecification, in lexical networks, 58, 275, 281

**W**

- weather verbs, 48, 278. *see* environmental verbs
- Wolof, 18, 37, 142, 165, 168, 205, 227, 261, 265, 284, 288, 289, 294
- worlds, possible, 118, 119, 120, 121