

# Sails as an aid to fishing

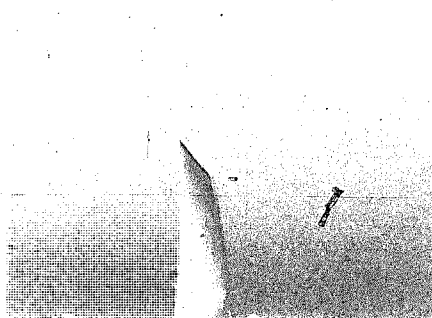
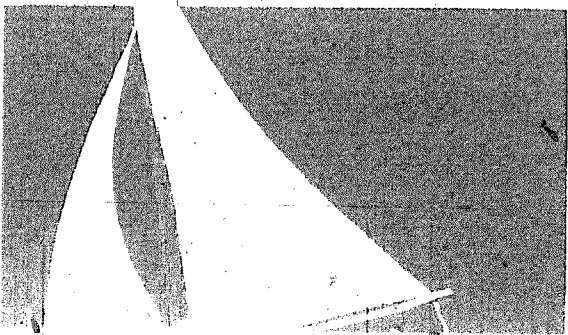
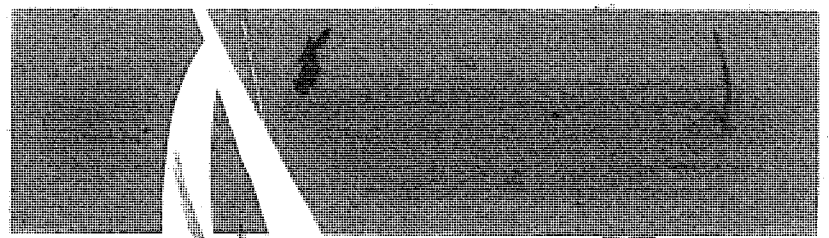
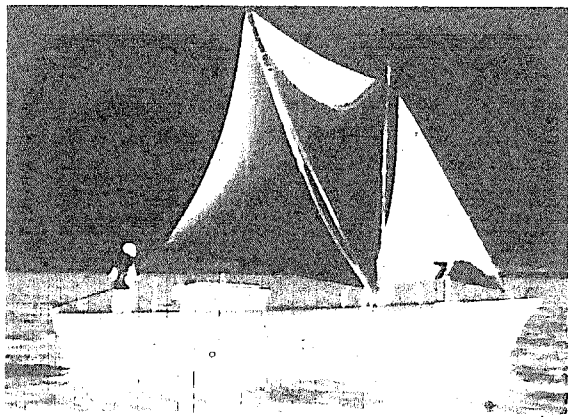

1988

MACALISTER ELLIOTT AND PARTNERS LTD  
ON BEHALF OF THE  
OVERSEAS DEVELOPMENT ADMINISTRATION

# SAILS AS AN AID TO FISHING

BY THE STAFF OF  
MACALISTER ELLIOTT AND PARTNERS LTD

ILLUSTRATIONS BY  
STUART BECK, RSMA  
AND THE STAFF OF  
MACALISTER ELLIOTT AND PARTNERS LTD

1988  
MACALISTER ELLIOTT AND PARTNERS LTD  
ON BEHALF OF THE  
OVERSEAS DEVELOPMENT ADMINISTRATION

© 1987 MacAlister Elliott and Partners Ltd

Reprinted 1988

#### ACKNOWLEDGEMENT

This book is the result of a continuing research programme funded by the Natural Resources and Environmental Department of the Overseas Development Administration of the British Government. The programme is being carried out by MacAlister Elliott and Partners Ltd, Naval Architects and Fisheries Consultants. The research is aimed at improving the performance and the fuel economy of sailing fishing craft in the developing world.

ISBN 0 9512495 0 9

Printed and bound in Great Britain by  
Biddles Ltd, Guildford and King's Lynn

## **Preface**

This book has been produced to help Fisheries Officers, community leaders and fisheries co-operatives introduce auxiliary sail to small-scale fisheries in developing countries, using simple techniques with locally-available materials.

It is divided into two sections. The first section contains all the information needed to make a decision as to whether or not auxiliary sail can be used to improve the effectiveness of a particular fishery, taking into account local factors which will vary from region to region.

It gives guidance on assessing the economics of a fuel-based fishery, and shows the likely advantages, savings and cost-effectiveness of auxiliary sail.

Taking existing boats and fishing methods, it explains in non-technical terms the principles, design and economics of sailing rigs, and how to construct and install them.

The second section of the book describes in detail five different sailing rigs, one or more of which should be suitable in any particular fishery. Having examined local conditions, existing boats and fishing methods, the reader will then be able to choose and design a sailing system from the simple rules and tabular information provided.

The terms used throughout are basic and the layout is pictorial and easy to follow.

This book does not attempt to give in-depth instruction on sailing techniques, but has enough information to allow sailing rigs to be installed and tested safely in sheltered waters.

Written by a team of experts specialising in fisheries development and management overseas, the book brings together considerable experience gained from sail projects in developing countries throughout the world.

# Contents

	Preface	
1.	History	1
2.	What is Sailing?	3
	How do Sails Work?	4
	Boat Shape	8
	Stability	10
3.	Commonly Used Rigs	12
4.	Is Sail Practical in Your Fishery?	14
	One – Wind and weather	14
	Two – Can our boats be adapted to use sailing rigs?	15
	Boat Shape	15
	Stability	16
	Layout	16
	Strength	16
	Three – Are suitable materials available at a reasonable cost?	17
	Four – Fishing Activities	18
5.	How much money can be saved by using sail?	19
	How much will the rig cost to make and maintain?	22
6.	The Decision – Is Sail Suitable In This Fishery?	25
	Is the wind and weather suitable?	26
	Can our existing boats be adapted to use sailing rigs?	26
	Are suitable materials available at a cost we can afford?	26
	Will the sailing Rig get in the way of the fishing?	26
	How much money can be saved by using sail?	27
	How much will the rig cost?	28
7.	Choosing and designing a rig	29
7.1.	Which is the best sailing rig for you?	29
7.2.	What measurements are Necessary to Work Out the Size of the Rig?	31
8.	Preparing the boat	35
8.1.	The Boat	35
8.2.	Boat Improvements	36
8.3.	Outriggers	38
8.4.	The Mast	42
8.5.	Standing Rigging	43

8.6.	Running Rigging	43
8.7.	Steering	44
8.8.	Rudder	44
8.9.	Steering Oar	47
9.	Making the Mast and Spars	49
9.1.	Mast Selection	49
9.2.	Wooden Mast Making	50
9.3.	Spar Selection	51
9.4.	Spar Making	52
10.	Making the Rigging	53
10.1.	Standing Rigging	53
10.2.	Running Rigging	55
10.3.	Splicing and Seizing	56
10.4.	Stepping the Mast	56
11.	Making the Sails	57
11.1.	Selection of Materials	57
11.2.	Sailmaking	59
	Tools needed for sailmaking	60
	Making the sails	60
12.	Attaching and Hoisting the Sails	69
	Lacing – method 1	69
	Lacing – method 2	70
	Halyards	71
	Maintenance of sails	72
13.	Testing and Sea Trials	73
14.	Performance Monitoring and Log Keeping	76
	Appendix 1 – Glossary of Terms	77
	Appendix 2 – Introduction to Rig	
	Description Appendices	89
	Appendix 3 – Lateen Rig	93
	Appendix 4 – Crab Claw Rig	99
	Appendix 5 – Sprit Rig	105
	Appendix 6 – Gunter Rig	113
	Appendix 7 – Dipping Lug Rig	121
	Appendix 8 – The Jib	129
	Appendix 9 – Conversion Tables	135

## **Note**

Italicised words throughout the book are explained fully in the Glossary of Terms on page 77.

## 1. History

Before the invention of engines, all fishing boats were sailed or paddled. Many fleets fished successfully over long distances and in severe weather. Even large trawlers operated under sail.

Over thousands of years, sails and boats were developed in different ways to suit particular conditions of weather, local geography and traditional fishing methods.

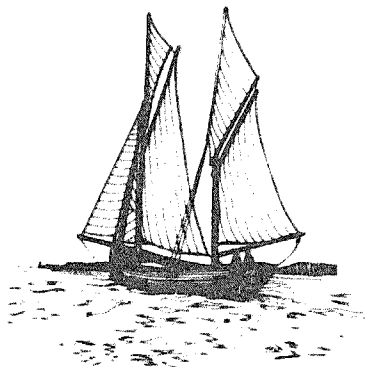

European Trawler

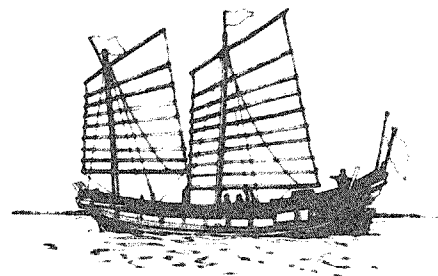

Junk

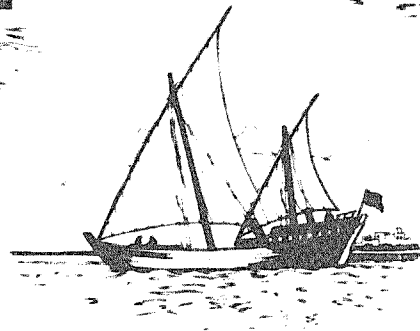

Dhow

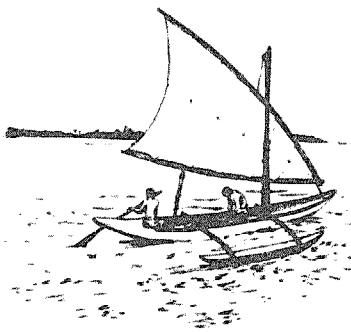

Polynesian Outrigger Canoe

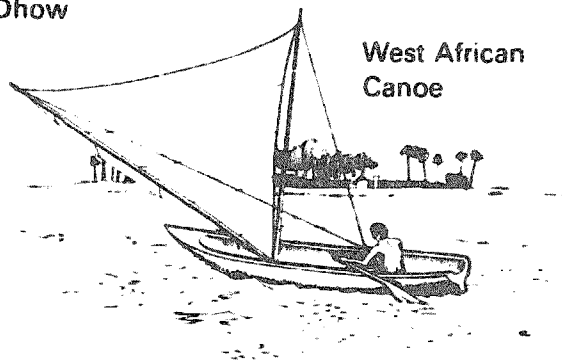

West African  
Canoe

In the first half of this century, fishing boats started to use engines, fuel was cheap and the use of sail declined. Since then, modern studies of sails and sailing methods have given us greater understanding of the advantages of using different types and combinations of *hull* and *rig*.



Fuel is often expensive now and locally in short supply. Today, when sails are fitted to working boats, they can reduce running costs and make fishing easier. We can retain the advantages of engines for efficient fishing, but can also save fuel, add speed and increase safety, by the use of sail. The use of sails to help, rather than replace, the engine in a boat is known as Auxiliary Sail.

In good conditions, a well-designed sail fitted to a small fishing boat can move the boat as fast as the engine will, and on many days of the year will save almost all the fuel. And if the engine breaks down, you can always sail to safety, whatever the distance.

There are disadvantages, of course, like extra gear in the boat, but the benefits of auxiliary sail are very real.

## 2. What is Sailing?

Sailing is using the wind to provide power for the boat. All boats will sail, some better than others. Boats will sail away from the wind, across the wind, or at an angle into the wind, but will not sail directly into the wind.

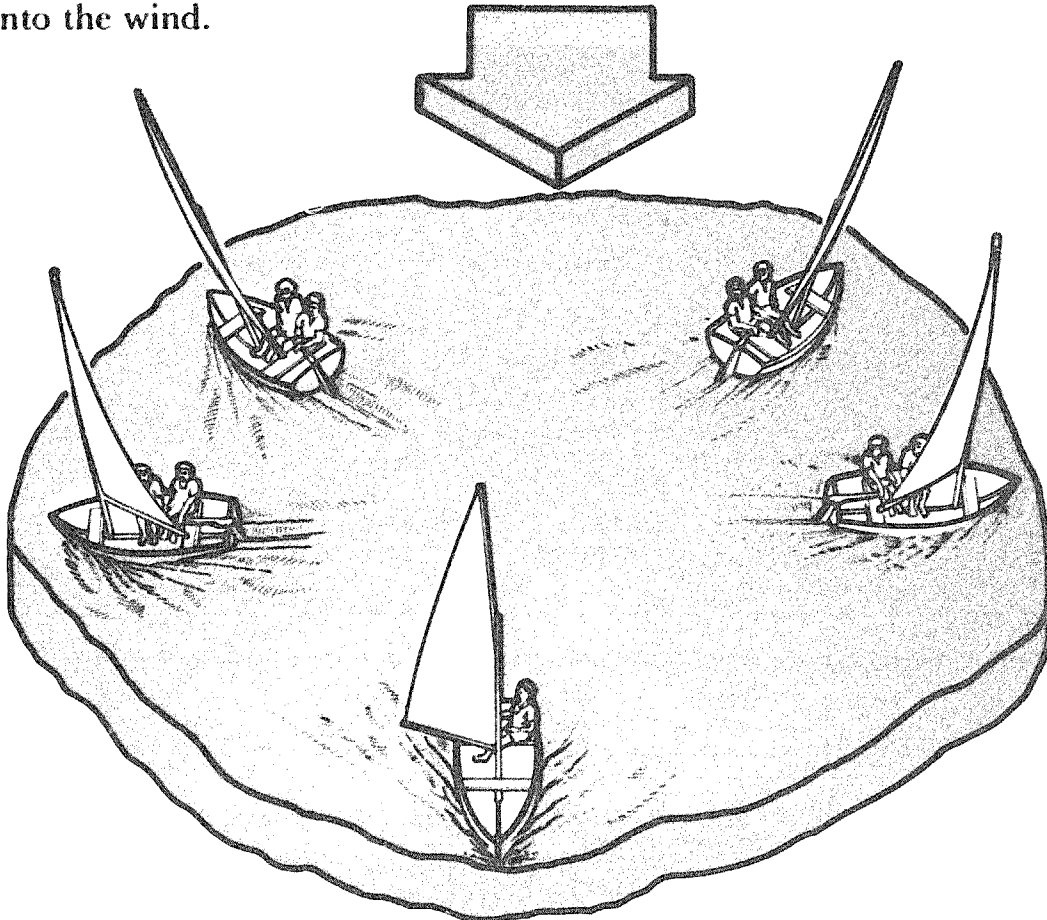

Sails, therefore, can be used to move a boat in nearly all directions, and the wind is free and will never run out.

**However:**

- Sails do not work when there is no wind;
- Sails cost money to buy and repair;
- Sails take up space and effort;
- Sails do not work equally well on all boats or in all directions.

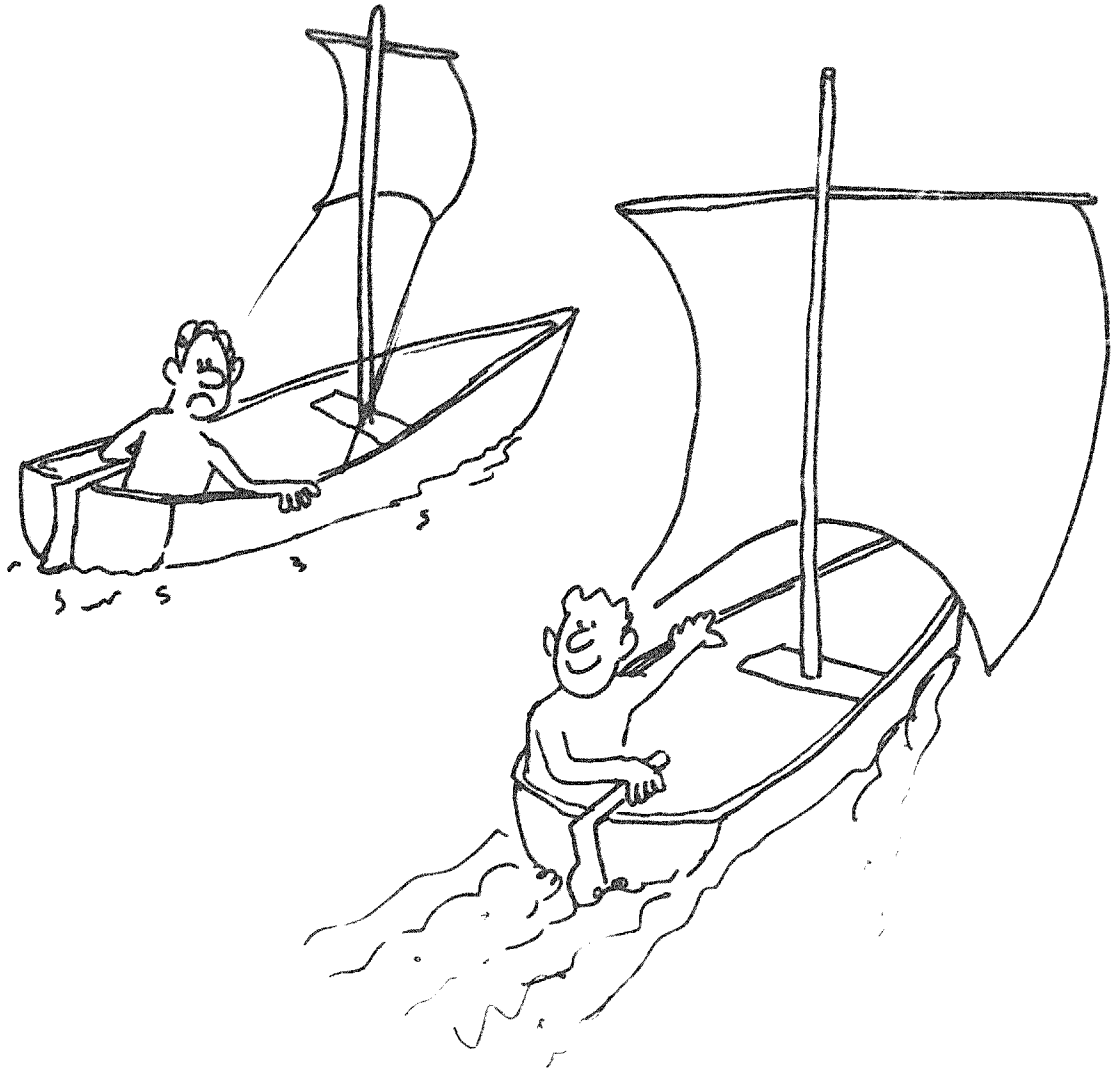

### **How Do Sails Work?**

Sailing away from the wind is easy to understand. The wind blows you along and the bigger the sail, the more it pushes. This is the *DOWN-WIND* force which you would expect.

Sailing across the wind or at an angle into the wind is not so easy to understand.

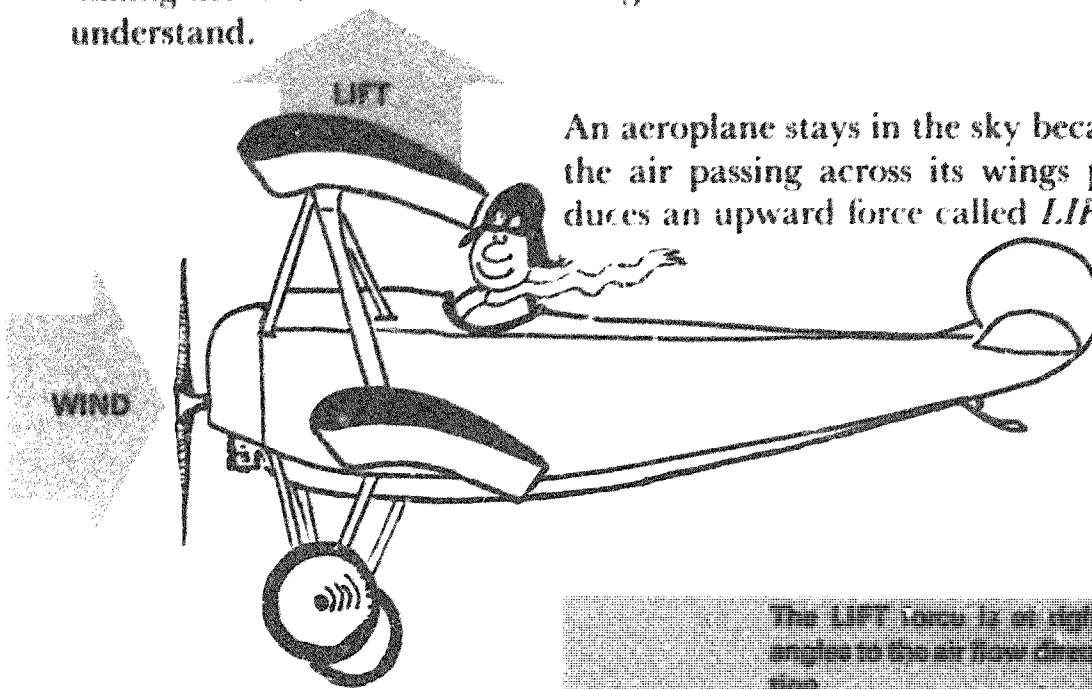

An aeroplane stays in the sky because the air passing across its wings produces an upward force called *LIFT*.

The *LIFT* force is at right angles to the air flow direction.

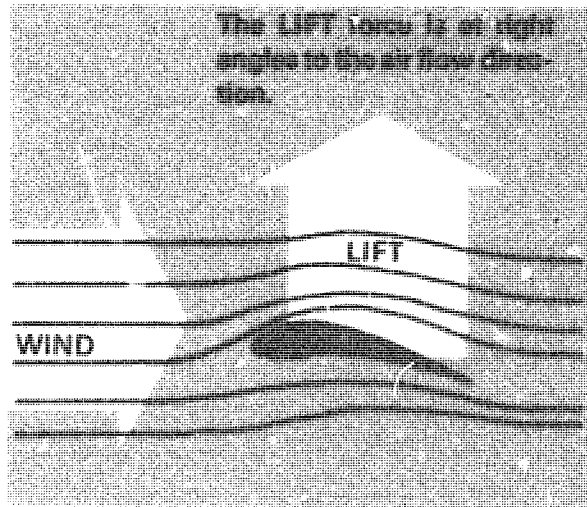

The same happens when wind blows across a sail, which is like a vertical wing on a boat.

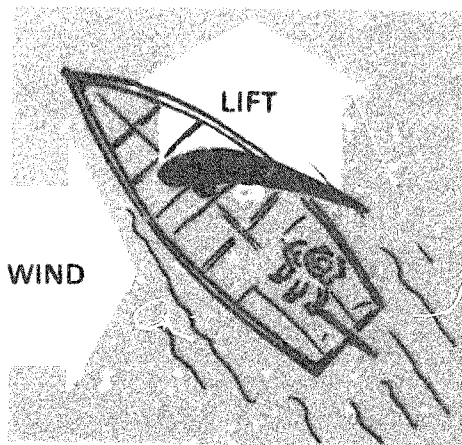

The important thing to understand is that wind blowing across a sail produces not only the expected **DOWNWIND** force, but also this **LIFT** force at right angles to the wind. It is this **LIFT** which enables sailing boats to sail across the wind and at an angle into the wind.

Now we can see how a boat can sail across the wind,

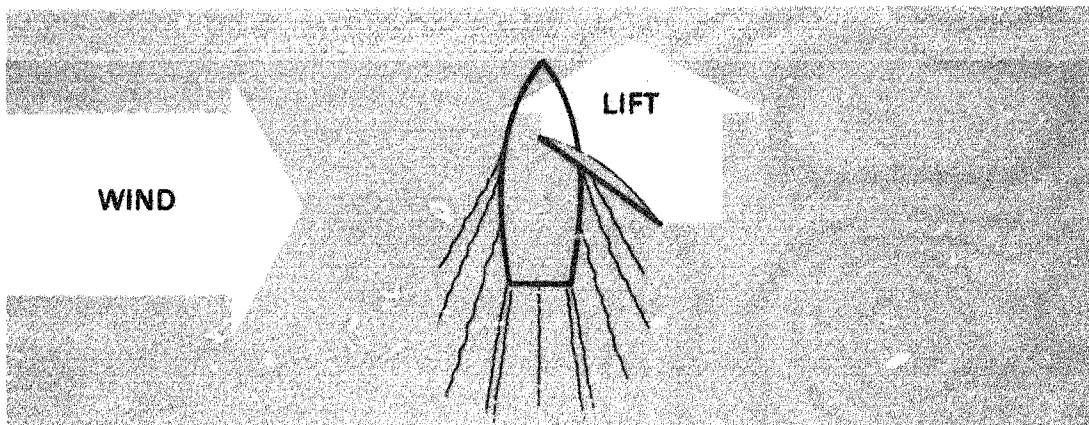

or at an angle into the wind, as the LIFT is still pulling the boat forwards.

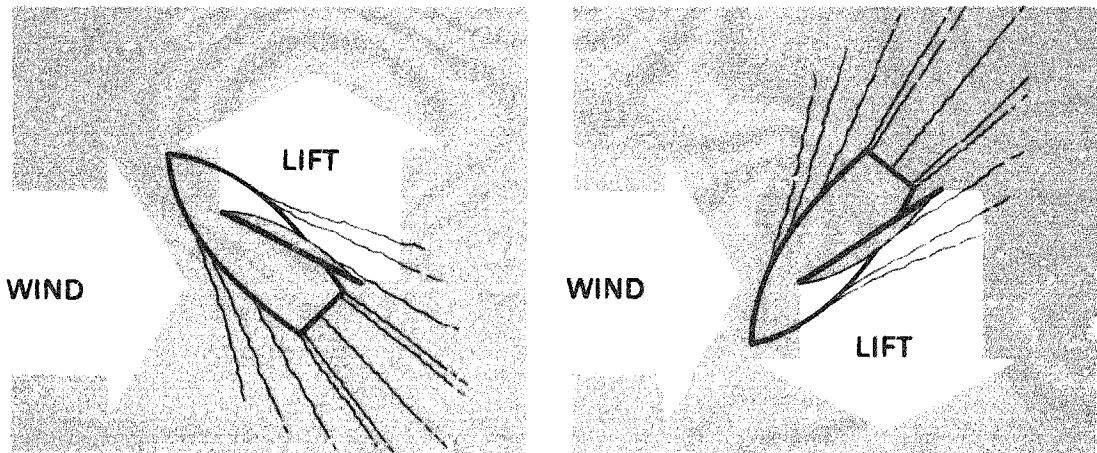

Now we can see how, by sailing zig-zag at an angle to the wind, a boat can make progress towards the wind. This is called *TACKING*.

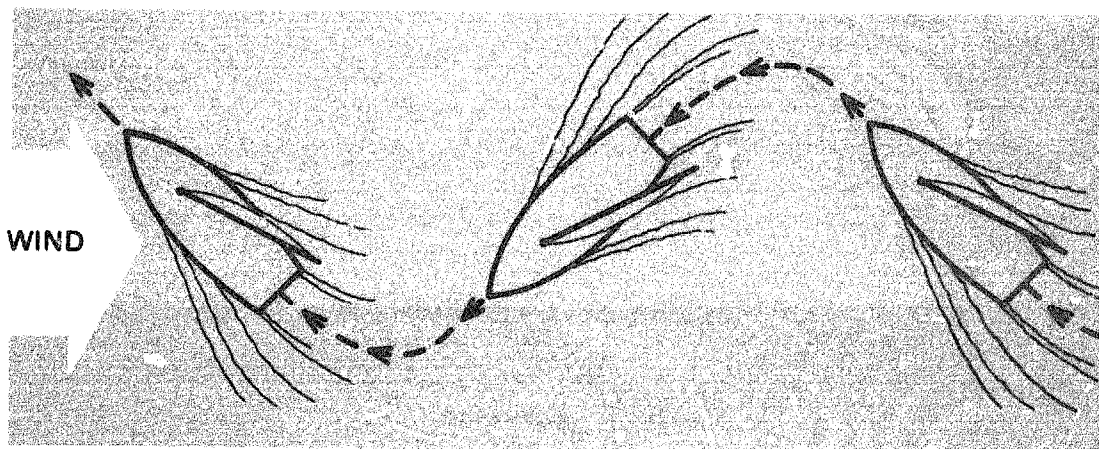

As one would expect, the wind blowing across the sail still tries to blow it downwind as well. However, well-shaped, well-controlled sails will produce high LIFT without too much downwind force for sailing across the wind, and can be spread out flat for sailing downwind.

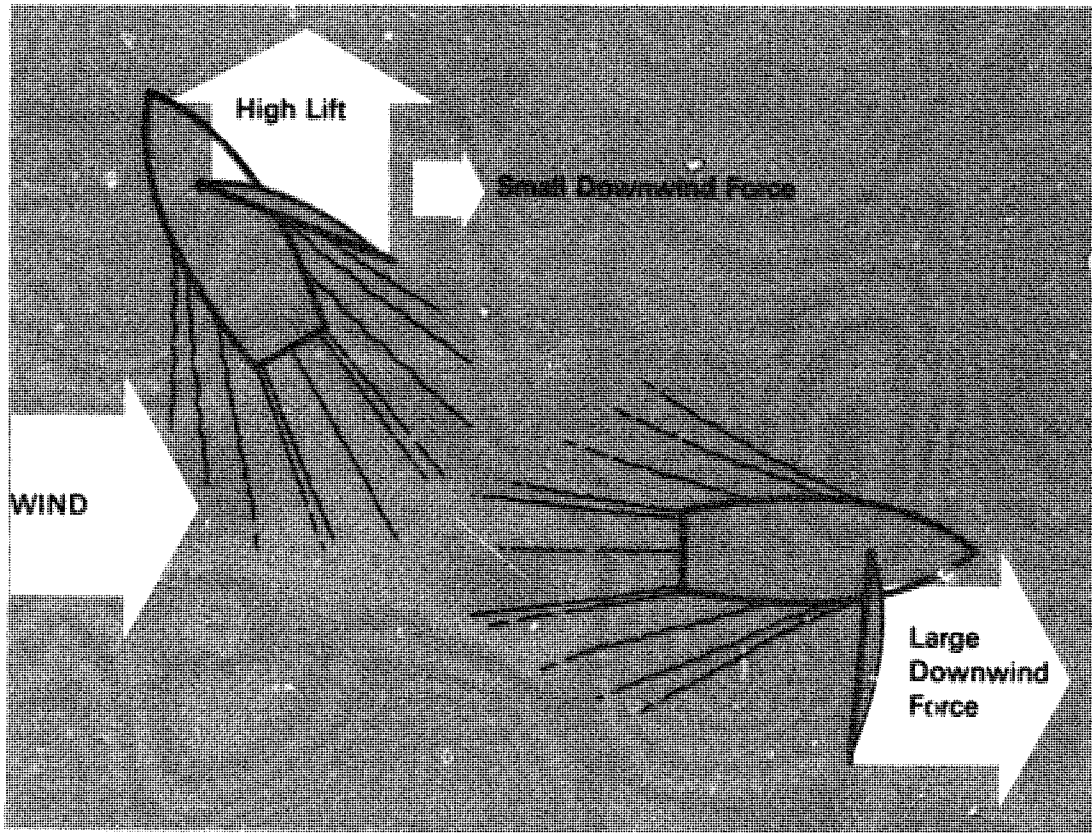

The size of these forces depends on several things:

- The size of the sail – a large sail produces bigger forces on the boat.
- The speed of the wind – a strong wind produces bigger forces on the sail and therefore on the boat.
- The shape of the sail – a sail needs to be well-shaped to produce good 'LIFT', but any sail will blow downwind.
- The control of the sail – the angle at which the sail is held to the wind is very important. You must be able to control the shape and angle of the sail.

We now know something about how sails work. To understand how boats sail we need to know about two other things.

ONE: The shape of the boat.

TWO: The *stability* of the boat.

### Boat Shape

If the boat is flat like a dish it will blow away from the wind whatever we do with the sails. What we need to sail well is a boat which goes easily through the water forwards, but which is difficult to push sideways through the water. This is why sailing boats have *keels* or *centreboards*. These are parts of the boat under water which are narrow if you look from the front of the boat, but are wide when looking from the side. This makes the boat easy to push forwards, but difficult to push sideways.

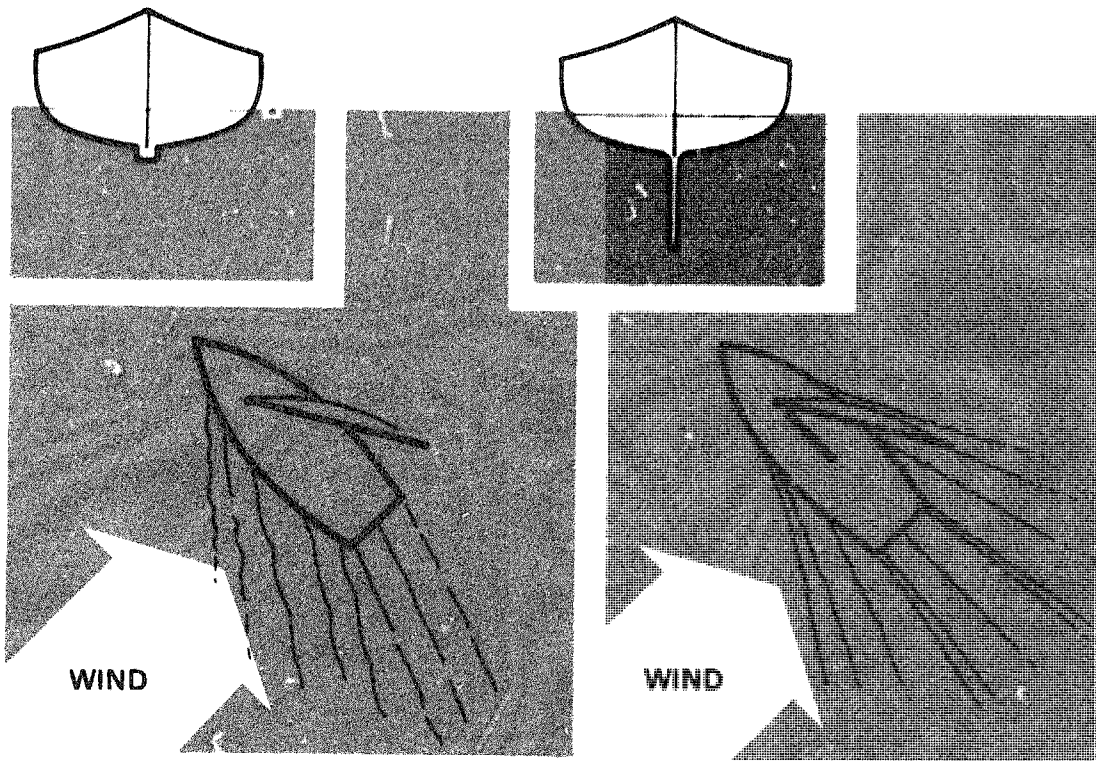



Here are some examples:

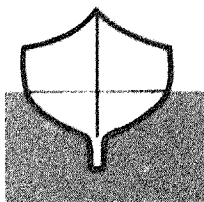
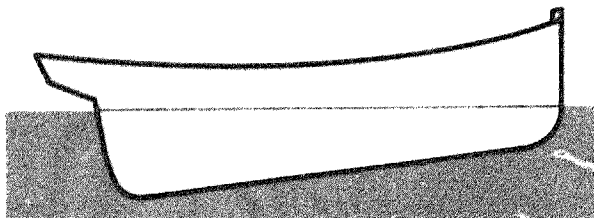

A big boat may have a keel like this.

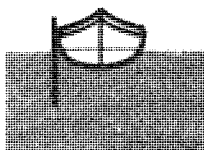
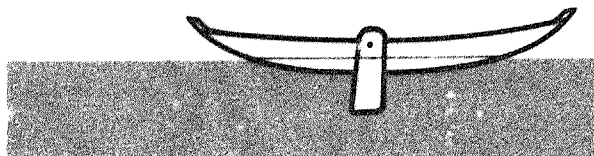

A canoe could have a *leeboard*.

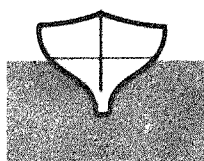
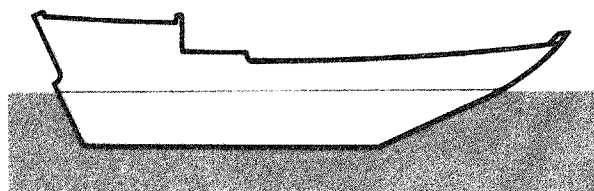

A dhow may have a different shape of keel.

A boat with no keel can be improved for sailing by fitting one of the following:

Centreboard sticking down through the bottom of the boat.

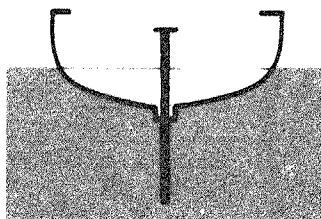

Leeboard attached to the side of the boat.

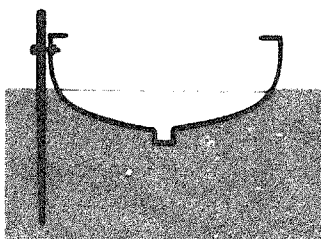

Keel Extension to the bottom of the boat.

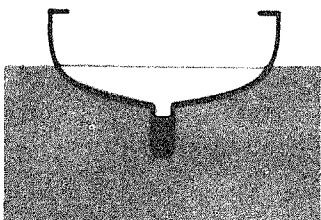



To Summarise: To sail well across the wind a boat must be easy to move forwards but difficult to push sideways.

### Stability

The stability of a boat is how hard it tries to stay upright when being tipped over by heavy fishing nets, people, waves or the wind on the sails. A boat is stable if a lot of people can stand on one side without tipping it over. A boat is unstable if it tips over easily.

Sailing boats should be designed NOT to *capsize*.

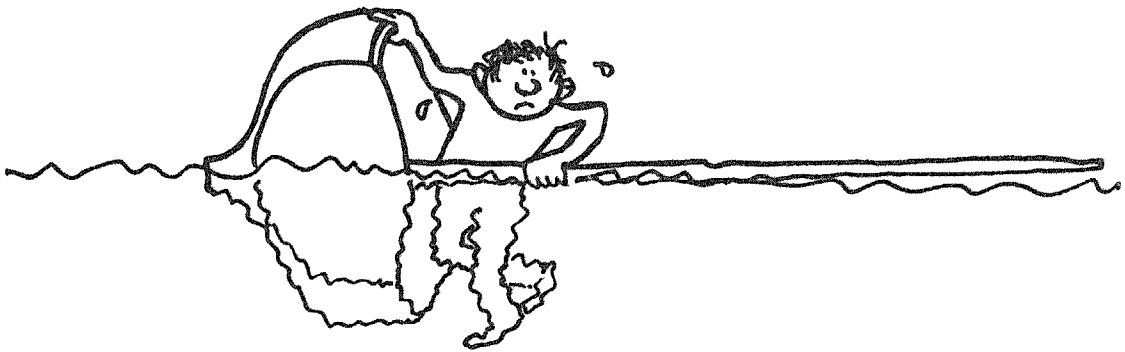

The wind blowing on the sail will always try to make the boat tip over (capsize). Even when sailing away from the wind, the boat will rock about. So you can see that a stable boat is better and safer for fishing and sailing. If the boat is small, the crew can help to stop it tipping over by moving their weight to the right place.

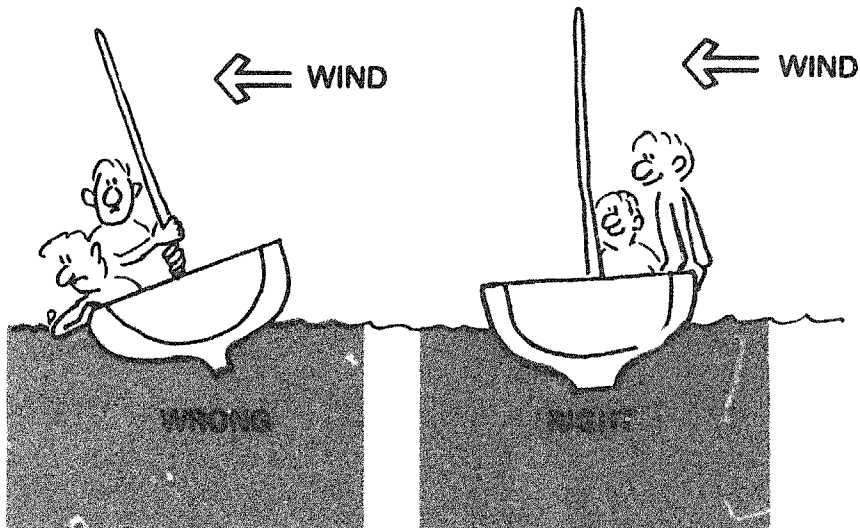

Here are four ways to make boats more stable.

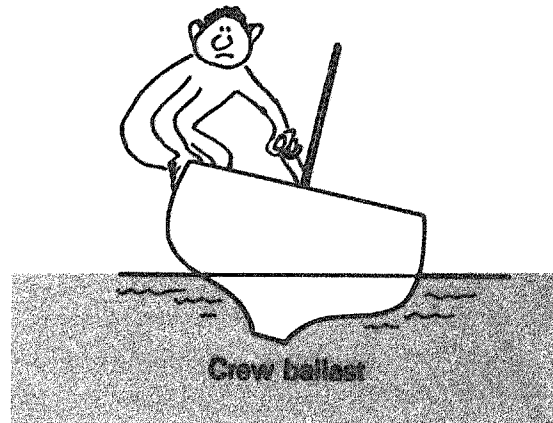
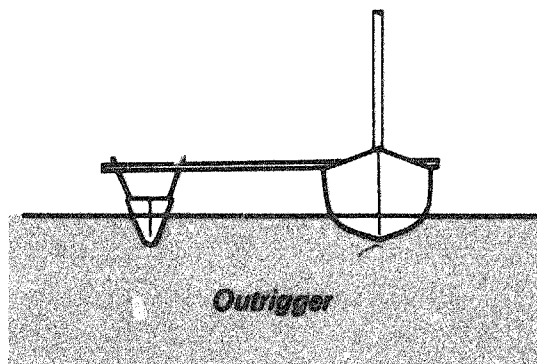
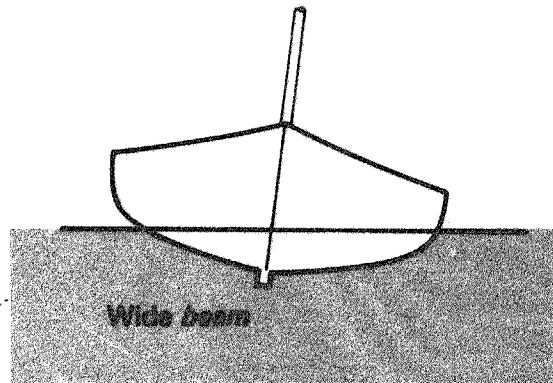
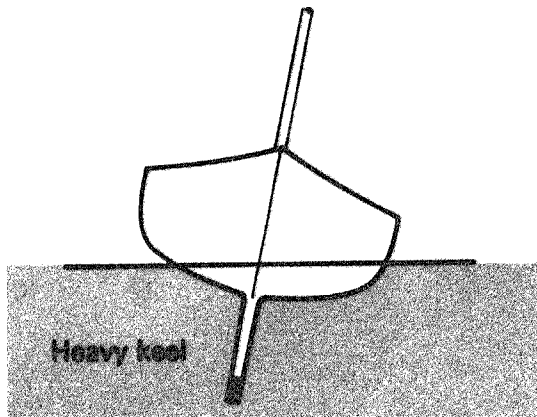

Let us summarise what we know about sailing:

- A. Sailing downwind depends on the amount of sail and the strength of the wind.
- B. Sailing across or towards the wind is made possible by "LIFT" in the sails and is affected by the shape of the sails. Well-shaped sails will have high LIFT and will sail at a closer angle into the wind.
- C. To sail well towards the wind, the boat must not slide sideways through the water – that is, it needs some keel area. Almost any shape of boat will sail downwind.
- D. The driving force from the sails will be limited if the boat leans over too easily. The boat must be stable enough to carry the sailing rig.

### 3. Commonly Used Rigs.

The purpose of a sailing rig is to hold up an area of material (the sail) to catch the force of the wind, and so move the boat through the water.

Since man first went to sea, many different sailing rigs have been developed; very many types evolved, not only to suit local conditions, but for a number of other reasons.

Obviously, the materials which were available locally would have been used to make *masts*, *spars* and *rigging*. The sails would also have been made from material which was easily found locally. The weather in the region, such as the usual wind direction and sea conditions, affected the size and shape of the hulls and sails of the local boats, and the distance and direction the fishermen were able to travel.

This book describes five different sailing rigs, one or more of which will be suitable for use in your fishery and, in Appendices 3 to 8, how to make and use them.

Any of these sail shapes may be used, depending on your choice based on Section 7.

Lateen

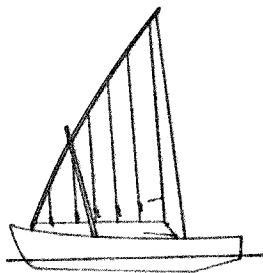

Triangular sail shape, with a long spar on the top edge.

Crab  
Claw

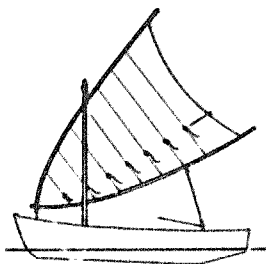

Three-sided sail with curved spars.

Sprit

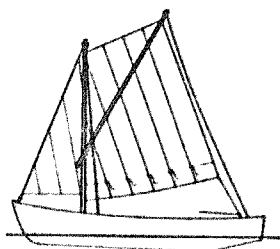

A four-sided sail supported by a long, strong spar.

Gunter

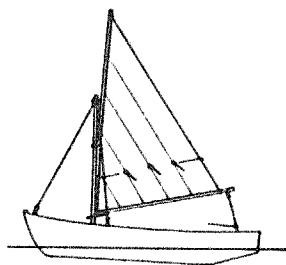

A good rig for a small boat. Four-sided sail, supported by an almost vertical spar.

Dipping  
Lug

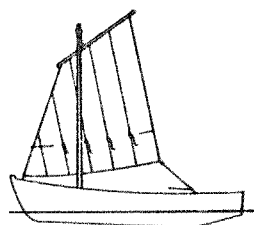

Simple, four-sided sail. A little harder to handle than other rigs. Very easy to make.

## 4. Is Sail Practical in Your Fishery?

Sail can be used successfully in most parts of the world, but there are obviously some places – such as areas with almost no wind – where sail will give little or no benefit.

Therefore, we need to answer the following questions:

- One – Are the wind and weather suitable?
- Two – Can our existing boats be adapted to use sailing rigs?
- Three – Are suitable materials available at a reasonable cost?
- Four – Will the sailing rig get in the way of fishing activities?

### One – Wind and weather

The ideal conditions for using sail are in winds of a constant strength, with a speed not below 7 *knots* and not above 22 knots (see Conversion Table, page 136). When the wind strength falls below 7 knots, it has little effect on normal sailing rigs. However, many fishing craft work successfully in very light winds by spreading large amounts of light-weight sail.

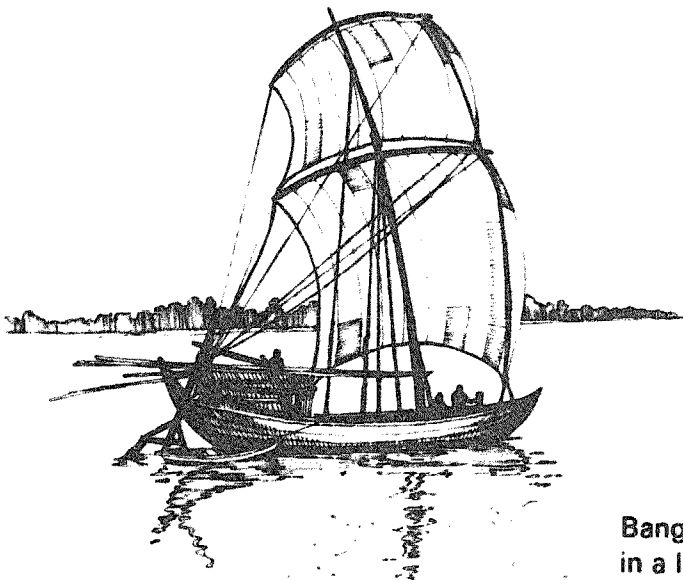

Bangladesh Inland Boat  
in a light breeze

When the wind speed is more than 22 knots, a strong boat can still sail well, but the sea will become rough, the forces on the hull and rig will be high, and the size of the sail may have to be reduced.

The worst conditions, then, are strong, unreliable, stormy winds, or no wind at all.

Think about the winds during the year and make an estimate of the amount of time that sail can be used in your region. Take into account the *sea breezes* which are caused by the sun heating up the land. They will be towards land when the sun is strong, and towards the sea in the night and early morning.

## **Two – Can our boats be adapted to use sailing rigs?**

Most boats can make use of sails. The few exceptions are:

- boats with little natural stability, such as some small dug-out canoes;
- boats that are too weak to carry rigging forces, such as reed boats or rotten boats;
- boats that simply have no space on deck for sailing equipment.

The suitability of the boat will depend on its shape, stability, layout and strength. Let us look at these in more detail.

### **Boat Shape**

As discussed in Chapter 2, the best boats move forward easily through the water, but are difficult to push sideways. Shallow boats will need additional underwater area – such as a leeboard or a keel extension.

## Stability

A boat's natural stability depends on one or more of the four examples already shown on page 11. These are: heavy keel; wide beam; outriggers and *crew ballast*. In practice, nearly all boats will be able to benefit from some form of sailing rig.

## Layout

There must be room on board to put up and operate the sailing rig. This may mean changing something else such as sun awnings or gentries. Some rigs fit into spaces better than others, but it must be possible to spread enough sail area near the middle of the boat.

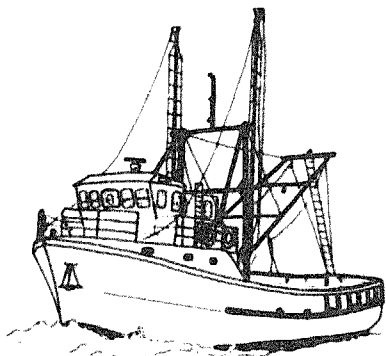

No room for sails



Must change sun shades

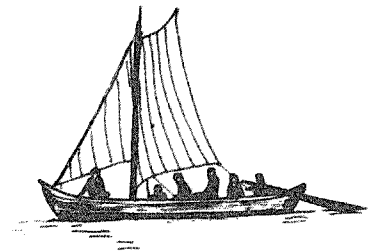

Easy

## Strength

The sailing rig will pull hard on the boat, in a different way to the strains caused by motoring, paddling or waves. The *stays* holding up the mast will pull upwards, trying to separate the hull *planking*; the leeboard, if any, will pull outwards on the top edge of the boat, and the pull of the steering may be higher.

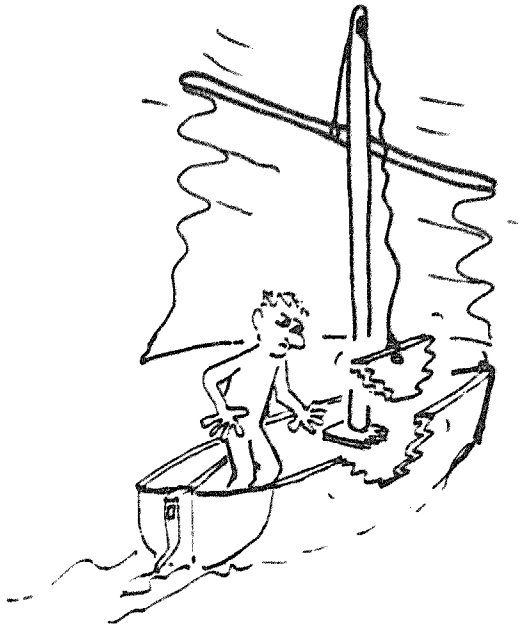

So, good boats for sailing need to be strong, or able to be strengthened without difficulty.

### **Three – Are suitable materials available at a reasonable cost?**

Most sailing materials will be available locally. However, check on the following items and their cost:

Masts and Spars	Long, straight timber or other light material such as aluminium tube.
Sail cloth	Close-weave cotton or synthetic material. Some plastic sacking is suitable.
Rope	Synthetic rope of various sizes (or natural fibres if strong).
Wire	Wire rope for <i>standing rigging</i> .
<i>Fastenings</i>	Nails, screws, nuts and bolts, etc.
Woodworking	Some woodworking tools.
Sailmaking	Local experience with sewing machines.

For smaller boats, the materials used can be very simple.



## **Four – Fishing Activities**

Some fisheries will benefit from sail more than others. There is little benefit for a fleet of trawlers which travel a short distance to the fishing grounds and then tow heavy fishing gear needing high engine power.

Fishing boats which travel many miles to fishing grounds, and use passive fishing methods such as hand lining and gill nets, may save a high proportion of their fuel by using sails. If their usual course direction is across the wind, they may do without engines or paddles altogether, except for manoeuvring or in calm periods.

### **It is worth remembering that:**

- more fuel is saved getting to the fishing grounds than during the fishing operation itself;
- routes across the wind are more efficient than into the wind and away from the wind;
- sea breezes can be useful for going out in the early morning and returning during the day.

## 5. How much money can be saved by using sail?

To answer this question we need to know the present fuel costs. If information for a group of boats for a whole year can be used, it will allow for seasonal fisheries and give a good idea of the savings possible. If this information is not available, costs may be taken from one boat during a period of fishing activity – though this will give a less accurate costing.

- Work out:
1. Cost of diesel or petrol (gasoline) used by the engine.
  2. For outboards, cost of 2-stroke fuel.

### Fuel Costs of 1 year or 1 season:

① AVERAGE FUEL USED PER DAY	<input type="text"/> LITRES
② AVERAGE FISHING DAYS PER BOAT	<input type="text"/> DAYS
COST OF FUEL ③ DIESEL PER LITRE	\$ <input type="text"/>
④ PETROL & 2 STROKE	\$ <input type="text"/>

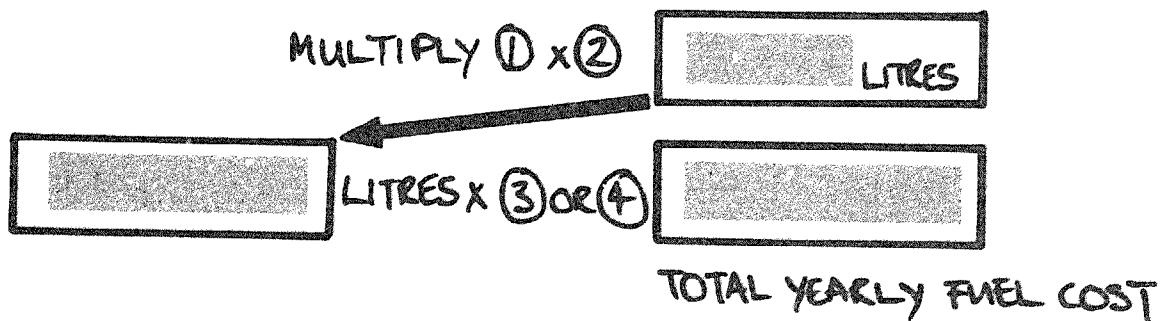

If the type of fishing alters at different times of the year (e.g. part of the year trawling and part gillnetting), then the above calculations should be done separately for each period.

The total fuel cost for the year often turns out to be much higher than expected.



We now have an idea of how much we spend on fuel, how good our weather conditions are, and if our fishing methods are suitable. Let us combine this information into a table and find out how much money may be saved.

## Fuel Costs Saved:

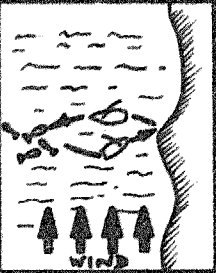
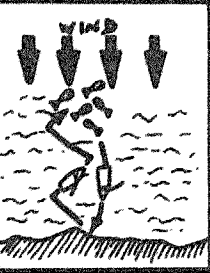
SAVINGS Percentage of Fuel costs.						
	CONSTANT WINDS		VARIABLE OR STORMY WINDS	REGULAR SEA BREEZES	CONSTANT WINDS	
TYPE OF FISHING	Strong	Light			Strong	Light
<u>SMALL BOATS</u>						
- long passage	80	40	15	20	50	20
- short passage	60	30	15	25	40	20
- inshore at night	40	20	5	50	30	10
<u>LARGE BOATS</u>						
- long passage	60	25	20	5	40	10
- short passage	40	10	10	15	25	5
<u>TRAWLERS</u>						
- long passage	30	10	10	5	25	5
- short passage	10	0	5	5	5	0
- trawling	5	0	0	0	5	0

## Notes:

1. Larger boats expect higher speeds and will need to use their engines more in light winds.
2. Inshore fishing benefits more from sea breezes than more distant fishing.
3. The above savings will depend on how good the materials available are for sailing rig making, and how well you set your sails.

By using the number in the table for the conditions nearest to yours, estimate the actual money which could be saved through using sail, as follows:

$$\text{Money saved} = \frac{\text{Fuel costs} \times \text{Percentage saving}}{100}$$

(page 19)                      (page 21)

As the engine is being used less, you can expect additional savings from lower maintenance and engine wear costs. You will also be able to increase fishing days if fuel is limited.

### How much will the rig cost to make and maintain?

To decide if sailing is going to be worthwhile, we need an idea of the costs involved. As a rough guide we can base this on the cost of the sail material. Remember this is a rough guide only. Accurate costings can be worked out later when the rig has been designed.

As a first estimate, for costing purposes only, the sail area will be as follows:

**Narrow canoe-type boats:**  $\text{Sail area} = \frac{L \times L}{4.5}$  (feet or metres)  
 where L = length of boat.

**Wider, more stable boats:**  $\text{Sail area} = \frac{L \times L}{2.5}$  (feet or metres)

Note that the resulting sail area can be in either square feet OR square metres, depending on how the boat was measured.

**Example**

Canoe, 7 metres long:  $\text{Sail area} = \frac{7 \times 7}{4.5} = 10.9 \text{ square metres}$

Wider boat,  
20 feet long:  $\text{Sail area} = \frac{20 \times 20}{2.5} = 160 \text{ square feet}$

---

Note: This sail area estimate is for costing only. No sails should be made before carrying out the tests in Chapter 7.

---

Find out the cost of sufficient sailcloth to make this area of sail (about 30% more than completed sail area).

Again, as a first estimate, the cost of the whole sailing rig will be about twice the cost of the cloth, or a bit more if many changes are necessary to the boat.

Each year about half of the rig cost will be spent on maintenance and replacements.

Thus, as a guide for decision making:

$$\begin{aligned} \text{Initial cost of rig} &= \text{cost of sail material} \times 2 \\ \text{Annual cost} &= \text{Initial cost} \div 2 \end{aligned}$$

We now have the cost of the sailing rig and already know the possible cash saving from reduced fuel consumption. The comparison is the most important factor in deciding whether or not sail would be beneficial. Obviously, the operation of a sailing rig will need more work than just running an engine, but the sail will get you home if the engine stops.

If you live in a remote area without regular supplies of fuel or mechanics nearby to repair your engine, the use of a good sailing rig will give you extra days fishing.

## 6. The Decision – Is Sail Suitable In This Fishery?

We have now worked out what sailing is, how sails work and which sailing rigs are most commonly used. In section 4 we looked at the things we have to think about to decide if sailing rigs could be practical in your area, and in section 5 how much money will be saved by using sail.

The following example, based on an actual fishing community which introduced sail when fuel problems became bad, will help you decide whether or not to introduce sail in your fishery.

---

The fishery consists of 10 boats, mostly of canoe type craft of about 7 metres in length. The boats are powered by small out-board motors and paddles. The local cost of fuel is 50 cents per litre. The fishermen use ring nets and handlines. They fish, on average, about 180 days each year.

The prevailing wind is light and blows along the shore, and the fishermen head straight out to sea across the wind. The wind is usually light to moderate, between 4 and 16 knots (see Conversion Table, page 136) and rarely strong. Most materials for making a rig are available.

---



The following questions were asked at the start of Chapter 4; we can now apply them to this example.

**Is the wind and weather suitable?**

Yes, the wind is steady and seldom very strong. It blows along the shore, which makes sailing to the fishing grounds easy.

**Can our existing boats be adapted to use sailing rigs?**

Yes, the boats are quite stable and can be made strong enough with simple changes. The boats are shallow and will slip sideways through the water, so a leeboard is needed.

**Are suitable materials available at a cost we can afford?**

Yes, wood is available for short masts and local bamboo can be used for the spars needed. Cotton cloth and synthetic rope can all be bought at reasonable cost.

**Will the sailing Rig get in the way of the fishing?**

No, the handline fishery will not be affected by a sailing rig but care will be needed when stowing the rig during ring netting. Fuel savings can be made since the journey to the fishing grounds can easily be made under sail. The addition of a rig does not interfere with fishing and gear handling.

In Chapter 5, we discussed how to find out annual fuel costs. We then combined them into a table which gave a percentage saving for particular types of boats.

If we now apply these calculations to the fishing fleet which we are using as an example, we find the following:

## How much money can be saved by using sail?

The following information was gathered from the fleet of 10 boats over a year of fishing:



① AVERAGE FUEL USED PER DAY	40 LITRES
② AVERAGE FISHING DAYS PER BOAT	180 DAYS
COST OF FUEL PER LITRE	③ DIESEL \$ —
	④ PETROL & 2 STROKE \$ 0.5
MULTIPLY ① x ②	
7200	7200 LITRES
LITRES x ③ or ④	\$ 3600
TOTAL YEARLY FUEL COST	

The amount of money spent on fuel by each boat is \$3,600 per year.

We have already seen from the table on page 21 that a small boat travelling a short distance across the wind and using passive fishing methods should show a fuel cost saving of about 30% per year.

From the example of the fishing fleet shown above, the saving per year is given by:

$$\text{Saving} = \$3,600 \times 30\% = \$1,080$$

SAVINGS (percent of funning cost)						
	CONSTANT WINDS		VARIABLE OR STEADY WINDS	REGULAR SEA REECES	CONSTANT WINDS	
	strong	light			strong	light
<b>SMALL BOATS</b>						
- long passage	80	40	15	20	50	20
- short passage	60	30	15	25	40	20
- inshore at night	40	20	5	50	30	10
<b>LARGE BOATS</b>						
- long passage	60	25	20	5	40	10
- short passage	40	10	10	15	25	5
<b>TRAWLERS</b>						
- long passages	30	10	10	5	25	5
- short passages	10	0	5	5	5	0
- trawling	5	0	0	0	5	0

The cost of a rig for a boat in the fishing fleet in our example can be worked out using the calculations shown on page 22.

<b>How much will the rig cost?</b>	
Sail area for 7 metre canoe = $\frac{7 \times 7}{4.5}$	= 10.9 square metres.
Cost of 10.9 square metres of locally available cotton	= \$59
Therefore, cost of whole rig (cotton price $\times$ 2)	= \$58
Allow for Leeboard	= \$ 6
<b>Total rig cost</b>	<b>= \$64</b>
<b>Total annual maintenance cost (rig cost <math>\div</math> 2)</b>	<b>= \$32</b>

From this we can see that for an outlay of \$64 on sails, a saving of \$1,080 can be made on fuel costs.

In this example there is clearly an economic advantage to using sail of about \$6 per trip, without any reduction in fishing effort.

In fact, the fishing community in the example increased their catches under sail due to greater range and safety, and at the same time reduced fuel costs.

The next part of the book explains how to choose, make, and fit a sailing rig.

## 7. Choosing and designing a rig

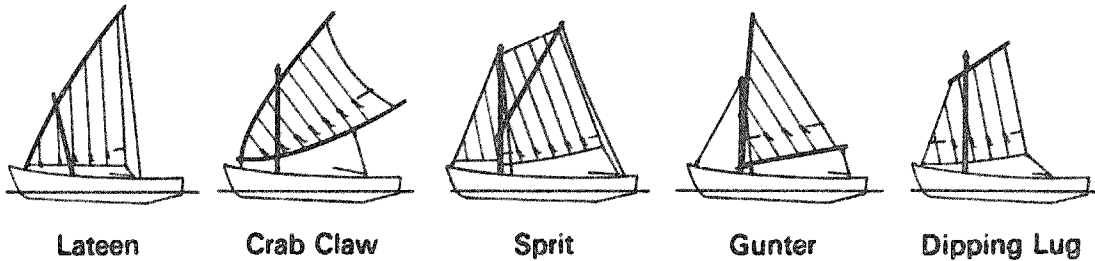

### 7.1. Which is the best sailing rig for you?

The five sailing rigs shown above are described in Appendices 3 to 8. Any of the sailing rigs will give good power if well-made and correctly used.

The choice of which rig to use should be based on:

- (a) Materials available, i.e., which rig can be built and controlled best, using only materials which are easily found in the area.
- (b) Some operational facts; for example, some rigs are easier to handle than others and may be better suited to certain fishing methods.
- (c) Usual wind and weather in the area.

Here are the main features of the five rigs. More details can be found in Appendices 3 to 8.

**Lateen** Traditional in many areas. Requires a long spar, but this can be made by lashing shorter lengths together. A good rig for setting a large sail on a short mast. Not good at sailing towards the wind and not easy to tack. Simple to make. Takes a lot of space in the boat when not in use.

- Crab Claw** Very efficient for sailing across the wind. Easily controlled with light spars and a short mast. Not easy to tack. Can be tied up the mast when not in use, away from fishing gear and crew. Quite simple to make.
- Sprit** Good all-purpose rig. Sprit spar is long and needs to be strong. Sail sets on quite a long mast. Tacks easily and can be tied out of the way while fishing. Can be used with a *jib* (see Appendix 8).
- Gunter** Good small boat rig. Short mast and spars. Tacks easily. Not best downwind. Can be used with a *jib*. Easy to tie out of the way when not in use.
- Dipping Lug** Simplest shape of all. Very easy to make. Short masts and spars. Not as easy to handle as some. Not easy to tack, but can be tied out of the way when not in use.

If in doubt, use the Sprit which is a good rig to suit most purposes. A *jib* can be added later if more sail is needed.

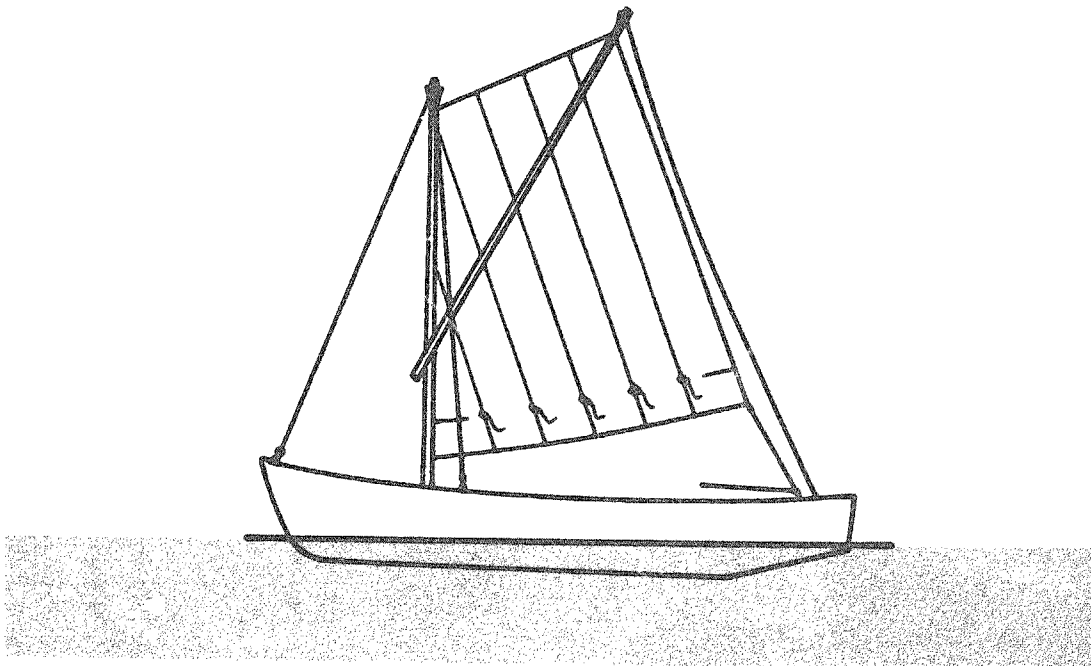

## 7.2. What measurements are Necessary to Work Out the Size of the Rig?

Whatever sailing rig is used, its total sail area must be in keeping with the size of the boat, and in particular with its stability (see Chapter 2).

Complete calculations are difficult and not necessary; there is a practical method of working out sail area which is very reliable. It is done by sitting people on one edge of the boat until it leans over to its maximum safe angle (as far as you wish it to go when sailing).

This will usually be just before water comes over the side of the boat.

This is how to do it:

- (a) The boat should be afloat in calm water.
- (b) Load the boat with the gear, equipment and normal number of crew, as for a fishing trip.
- (c) Sit or stand men halfway along the boat on one edge. Add more men on the same side until the boat leans to the maximum angle to which it can safely lean under sail.

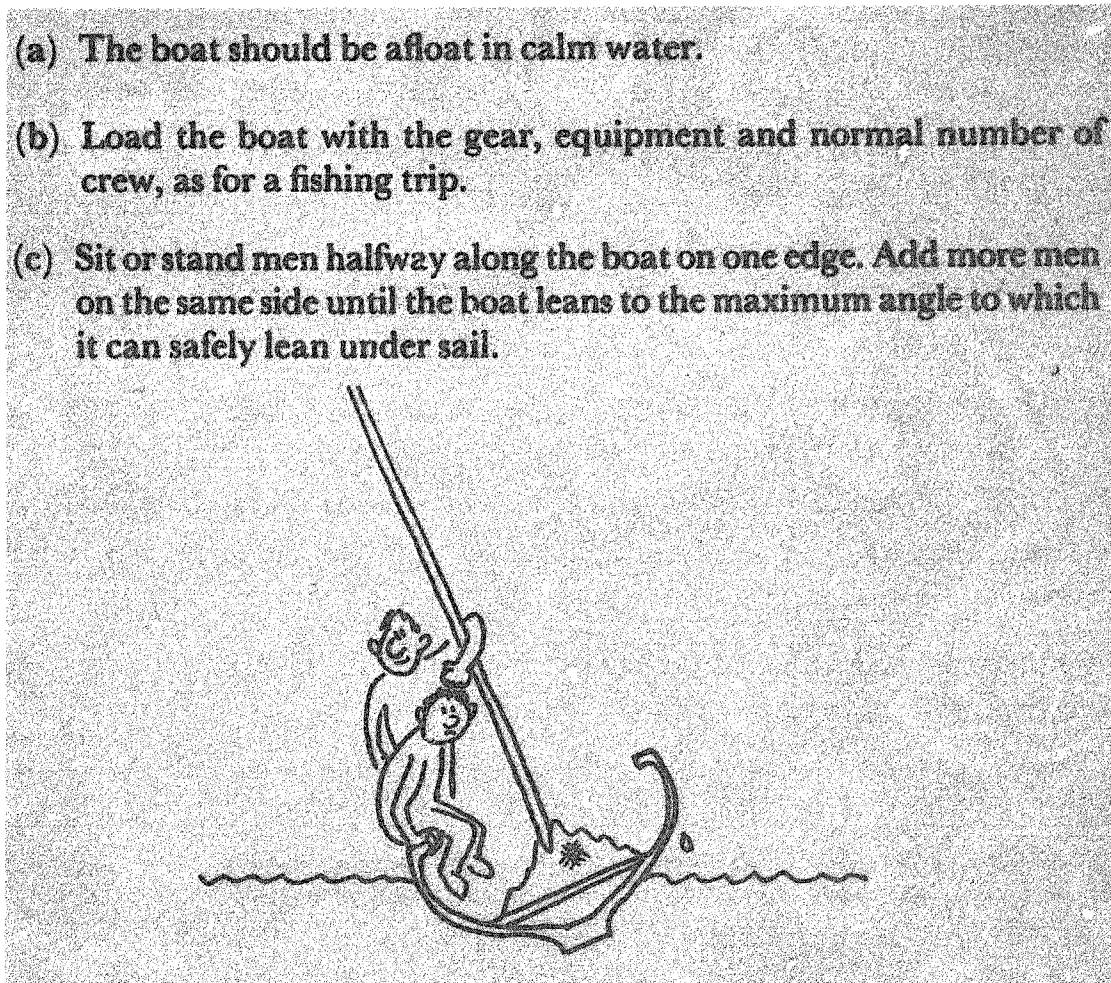



If the crew would normally sit on one side of the boat when sailing to help keep the boat level, then they should do so during this test. This will allow more men on the other edge to lean it over to its maximum safe angle.

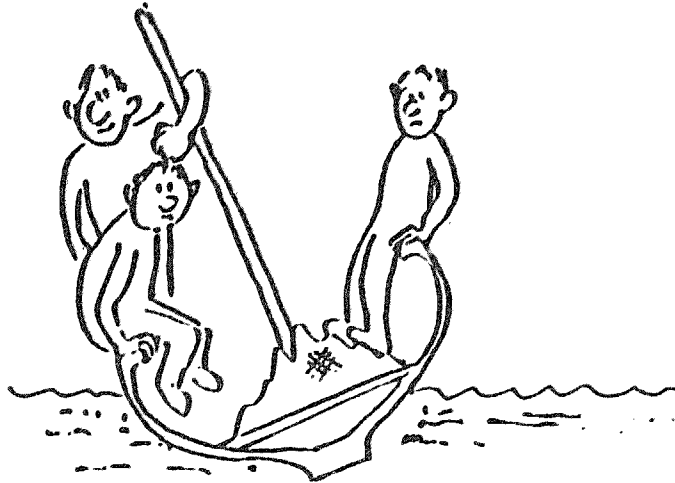

- (d) Count the men needed on the edge to lean the boat over to its maximum safe angle. Do not count the normal crew.
- (e) Measure the width of the hull of the boat at the widest part.

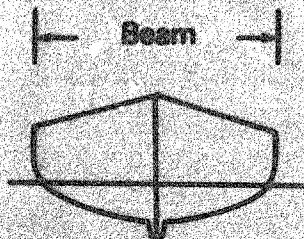

- (f) Measure the length of the hull of the boat.

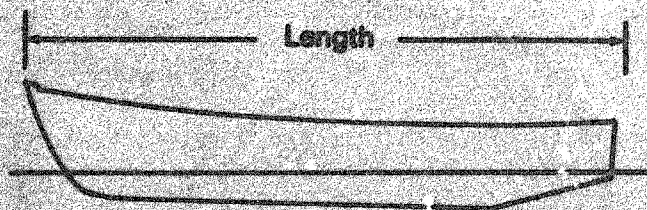

Now for the Optimum Design Area formula (ODA formula):

$$\text{Sail area} = \frac{N \times B \times 10}{L} \text{ in square metres}$$

I.e. N multiplied by B multiplied by 10, divided by L.  
 where N = number of people on the edge  
 B = width in metres  
 L = length in metres

or

$$\text{Sail area} = \frac{N \times B \times 100}{L} \text{ in square feet}$$

I.e. N multiplied by B multiplied by 100, divided by L.  
 where N = number of people on the edge  
 B = width in feet  
 L = length in feet

The ODA formula will give a sail area suitable for 20 knots of wind – see Conversion Table, page 136. If your winds are usually less than 20 knots you will need more sail, and with more than 20 knots, less sail.

The formula gives the total amount of sail whether in one piece (e.g. Dipping Lug) or in two pieces (e.g. Gunter with jib).

The formula assumes people weighing 70 kg (154 lb) on the edge of the boat. Thin people will give too large a sail area; fat people will give too small an area.

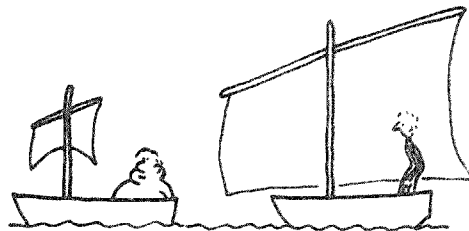

**Caution.** The ODA formula will tend to over-estimate sail area on twin-hulled boats.



The Sail Area, Width and Length of the boat are the only measurements needed to design the sailing rig. The shapes, sizes and quantities of everything in the rig can now be looked up in the Rig Tables in Appendix 3 to Appendix 8.

## 8. Preparing the boat

Even if your fishing boat is already strongly built to make it seaworthy, it will still need to have some changes made when it is fitted with a sailing rig for the first time.

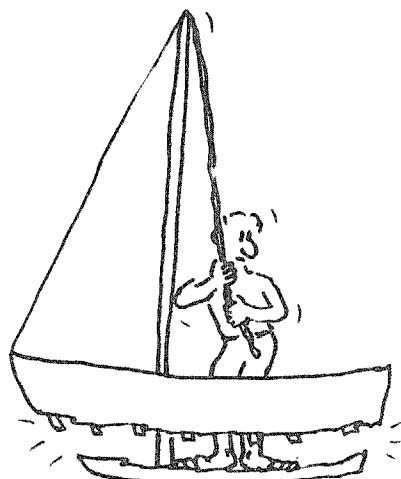

The rigging tries to pull the sides of the boat up and the mast pushes the keel down.

### 8.1. The Boat

The strains on a boat under sail are different from those when motoring or paddling. The rigging tries to pull the sides of the boat up and the mast pushes the keel down. Make sure the *frames* are strong enough. It is sometimes necessary to fasten some extra frames beside the old ones.

The boat will often be *heeled* at an angle for some time, so parts of the boat which usually stay dry may be under water. Extra *caulking* is needed to stop leaks in wooden planked boats. A boat which has loose planks will leak more than ever when sailing.

*Rudders* or steering oars will be used with more force, more often than when using a motor. Fittings need to be made stronger.

## 8.2. Boat Improvements

The sailing performance of most fishing boats can be improved by making the boat deeper, or using boards over the side (leeboards) or through the middle (centreboards) to stop the boat sliding sideways. See Chapter 2.

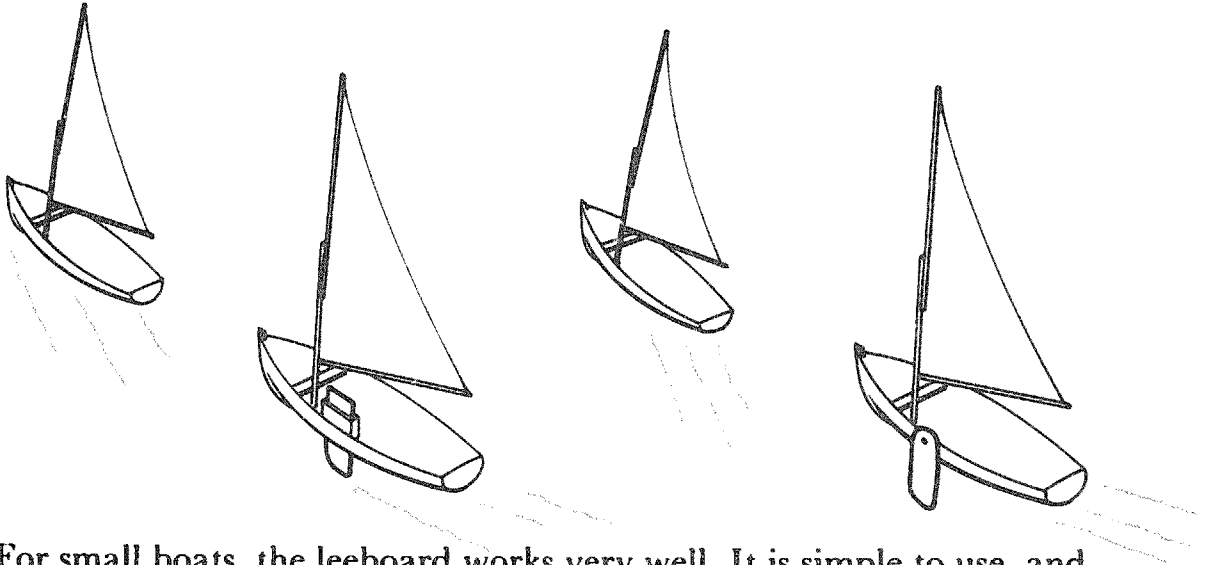

For small boats, the leeboard works very well. It is simple to use, and easy to fit to the side of the boat. Make sure that the side of the boat is strong enough to stop the leeboard pulling it out of shape.

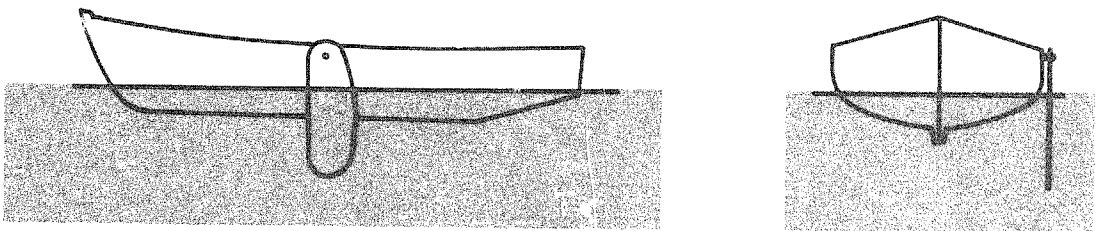

There are several ways of fixing a leeboard to a boat:

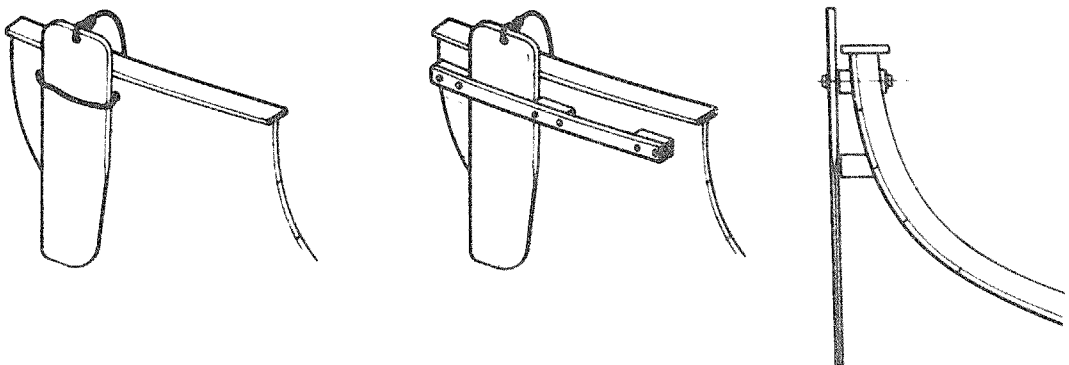

A better improvement is the centreboard, but this needs more changes to the boat than a leeboard.

The narrow opening in the centre of the boat through which the centreboard slides can be made through the keel or to one side of it. The keel in this area should be strengthened to stop leaks around the centreboard. The box in which the board will fit needs to be higher than the *waterline* when the boat is loaded, and should be supported by a cross-member at the top.

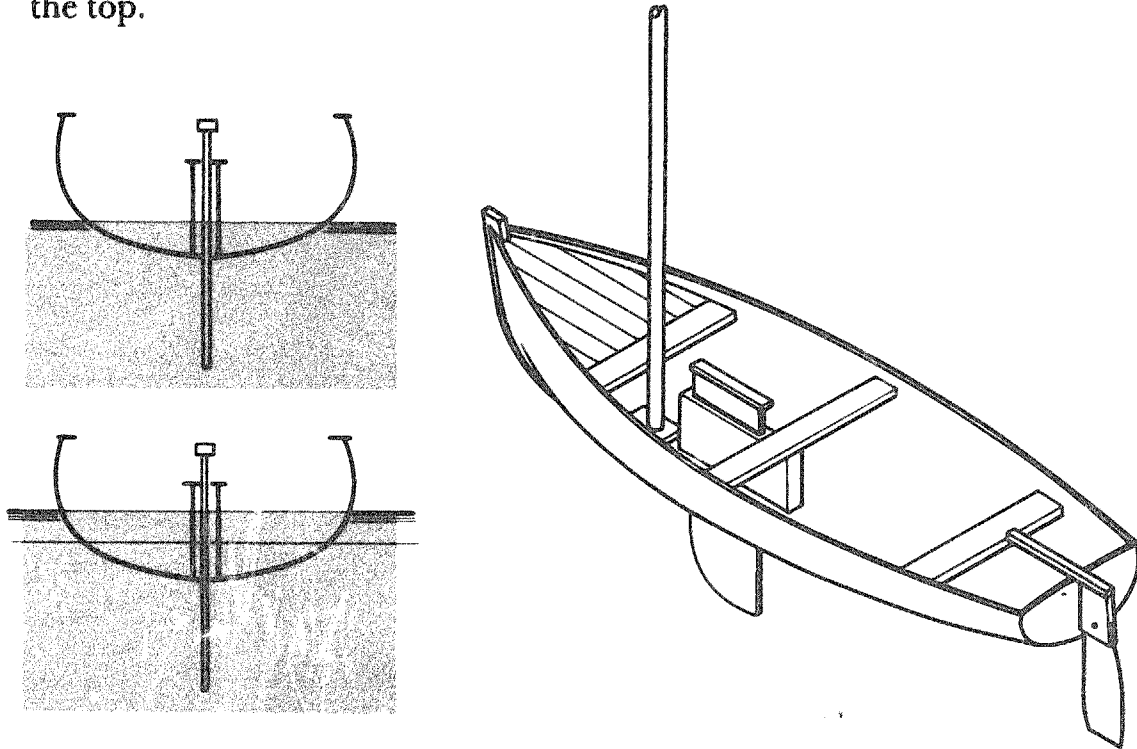

The position of the leeboard or centreboard is generally just behind the mast. If it is too far forward or too far back, it will make steering difficult. A leeboard can easily be moved forwards and backwards while sailing to get the right balance, but if you decide to fit a centreboard, then sail first with a leeboard until you have decided on the position.

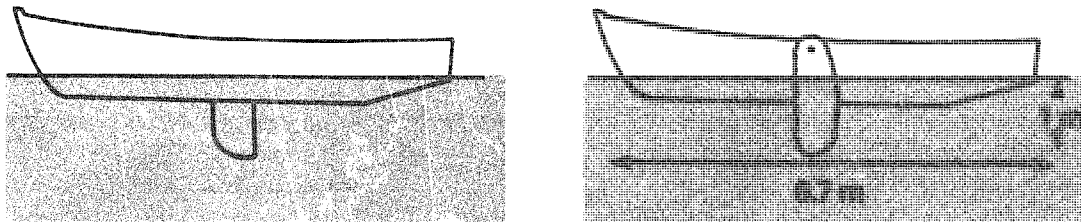

Leeboards and centreboards can be made from hardwood planks of 20-30 mm thickness. For boats of 6-7 metres long, the board needs to be about 600 mm wide, and should have about one metre below the water. So, the length of the board should be one metre plus the height of the boat's side.

The addition of depth to the keel will have a similar effect and is often easier to do, an additional timber keel being fastened under the existing keel. A depth of 200-300 mm will be enough for a boat 6 or 7 metres long, but this may be too deep if you are working in areas with shallow water or from a beach.

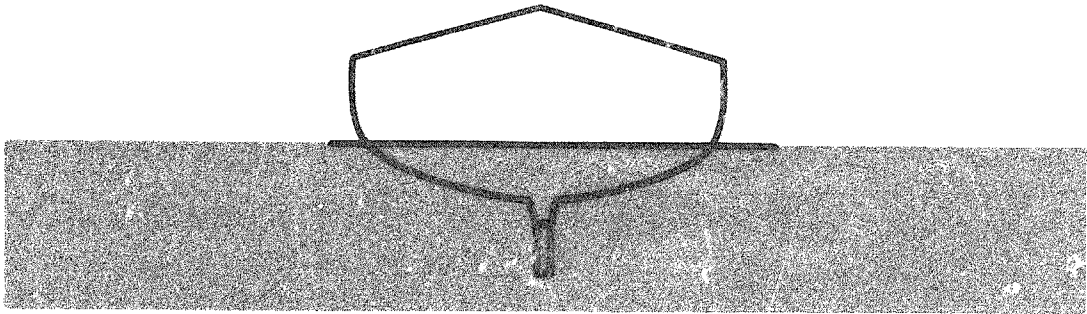

### 8.3. Outriggers

Some small boats such as dug-out canoes are not stable enough to carry sails. This is because a sail makes a boat lean over and if the wind is strong, the boat may lean too far and fill with water. From Chapter 2 you can see that there are many ways to make a boat more stable; one of the best is to fix an outrigger to one side of the boat.

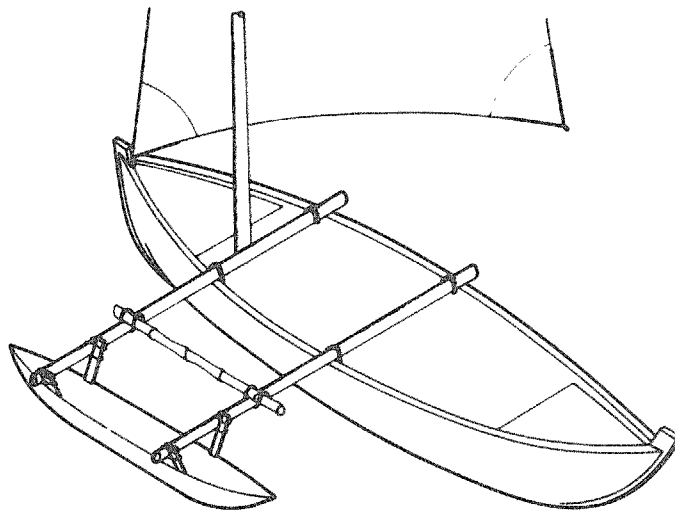

An outrigger is like a small canoe which is fixed to the boat with poles. The outrigger must not fill with water so it is decked over and made as watertight as possible. It may be fixed on either side.

The outrigger is usually about half the length of the boat and is not as deep or wide as the boat to which it is fixed. For example, an 8 m to 10 m (26 ft to 33 ft) canoe could use an outrigger of between 4 m and 5 m (13 ft and 16 ft) long. This outrigger should be roughly 0.33 m (1 ft) wide and 0.33 m (1 ft) deep.

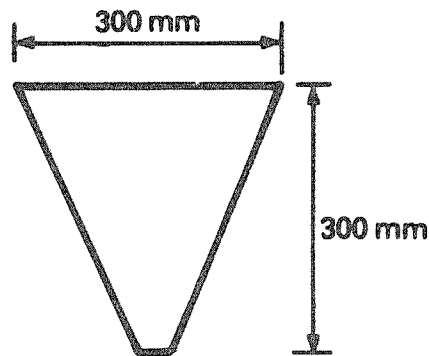

(The size will also depend on what materials you have available to make the outrigger.)

Here is how the outrigger works:  
If the wind is blowing from this side, the outrigger is pushed under water as the boat leans over. This stops the boat leaning over too far.

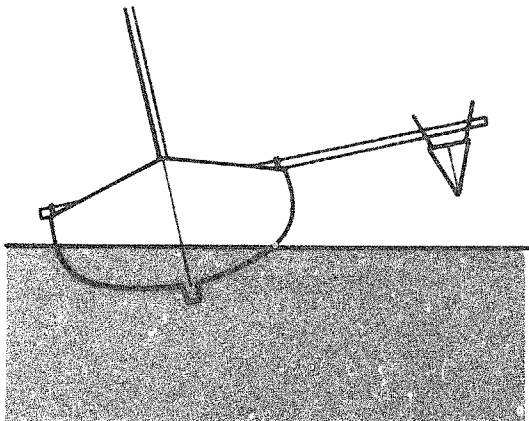
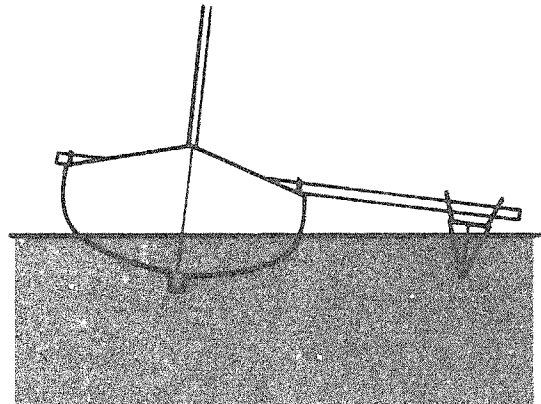

If the wind is blowing from this side, the outrigger is lifted out of the water as the boat leans over. This time it stops the boat leaning too far by balancing the wind pressure.

Outriggers may be made in a number of shapes, for example:

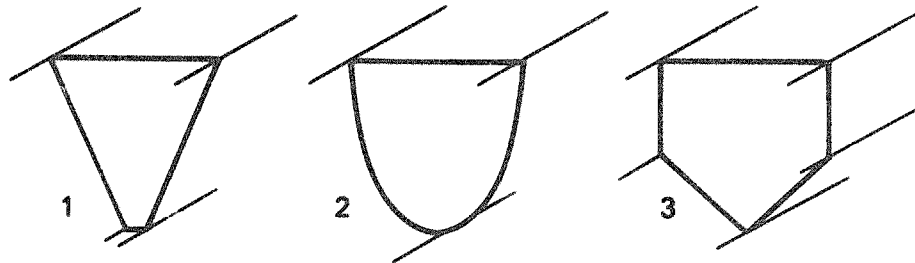

The best shape is similar to number 1. The 'V' shape helps to stop the boat slipping sideways.

An outrigger can be made by any method which is used for normal boat-building, for example:

- A dug-out canoe with deck
- Plywood
- Glassfibre
- Wood planking.

The best materials for poles are trees about 100 mm to 150 mm thick. The figure below shows the best way of fixing the outrigger.

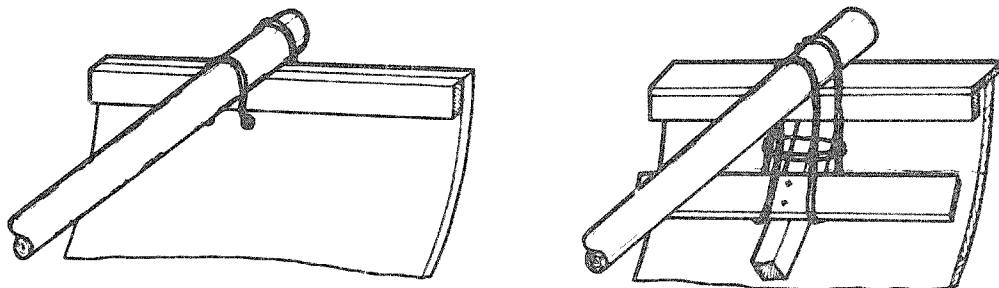

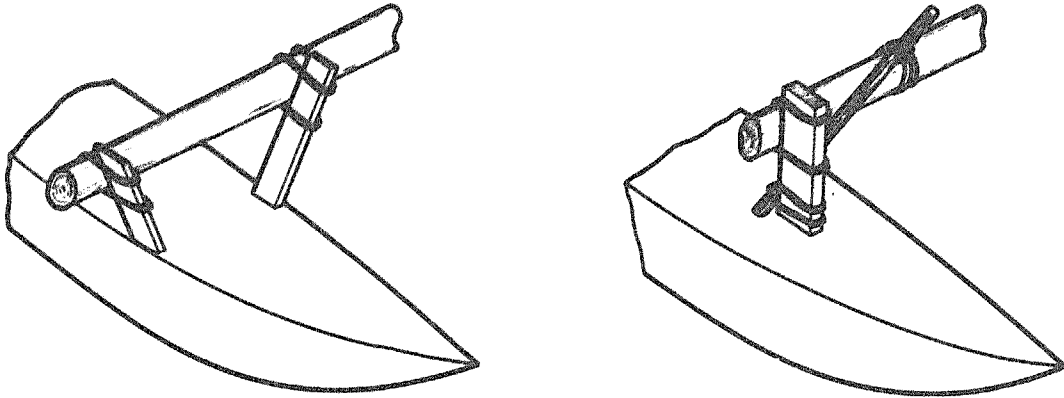

Having built and fitted the outrigger, you still need to think about the size of the sail you need. If you read pages 31 to 34 again, you will recall the way in which the size of sail can be worked out. The method is the same for a boat with an outrigger but there are some things to remember:

- (a) When you measure the width of the hull, only include the hull of the boat. **DO NOT** include the outrigger in this measurement.
- (b) When you tip the boat over, and count the number of men needed, tip the boat until the outrigger is pushed right under water. (This will also test if your outrigger poles are strong enough.)

Now you can carry out the calculation.

The outrigger will add to the cost of making and maintaining your boat. Look at pages 27 and 28 again and add the cost of the outrigger, outrigger poles and fixings. The maintenance cost will depend on the material you make the outrigger from, but somewhere between a third and a half of the total cost of the outrigger will have to be spent each year for maintenance.



## 8.4. The Mast

The position of the mast is usually about one third of the overall length from the front of the boat. The mast should stand on a *step* made from hardwood and fastened between floor timbers or frames. The *mast step* needs to be strongly fastened to the frames, so that it will not move sideways as the sail pushes against the mast. Make a central hole through the step into which the bottom of the mast will fit.

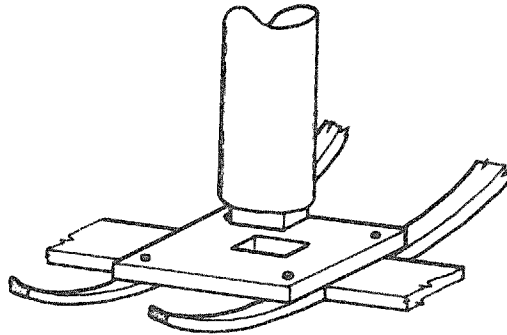

The mast must be supported either by the *deck* or by a *cross-member*; it may be already there, such as a *thwart*, or you may need to make and fit one. The cross-member needs to be as high up in the boat as possible, and strongly fastened to the boat's frames, as the sideways force from the sail pushing on the mast will be high.

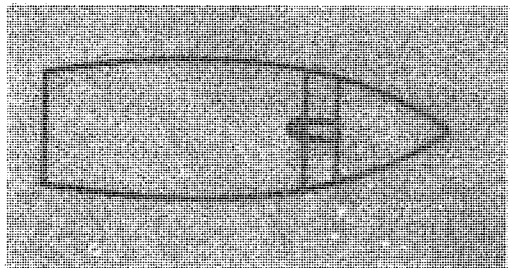
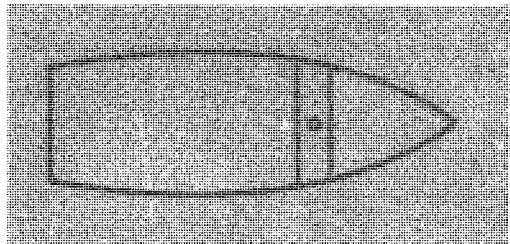
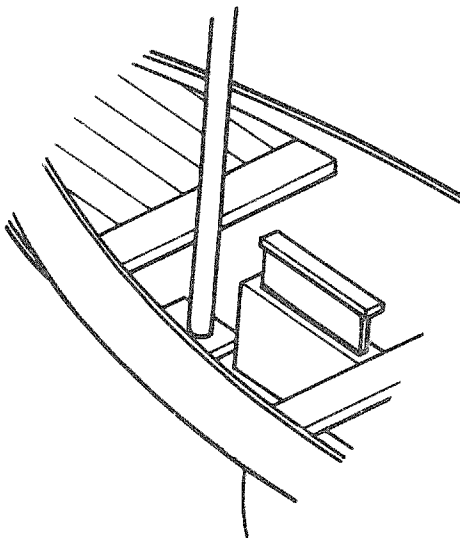

The mast can be put through a hole made in the deck or cross-member, or *lashed* in position against the rear edge of the cross-member.

### 8.5. Standing Rigging

Some masts are supported by standing rigging (wires or sometimes ropes) from the edge of the boat up to the top of the mast. These are called stays and shrouds.

The points on the boat where this rigging is attached, both on the front and at either side, need to be strong so that the rigging does not pull the boat apart. This can be done by fitting extra *knees* and cross-members fastened to the boat's frames.

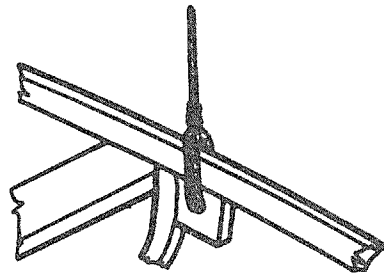

### 8.6. Running Rigging

The sails and spars are raised, lowered and controlled by running rigging, usually ropes. Attachment points for running rigging lines need to be strong, and positioned to be clear of fishing gear. The *halyard* ropes for raising or holding up the sails may hold heavy loads and may have to be released quickly. These lines should be led to *cleats* positioned on the mast support cross-member.

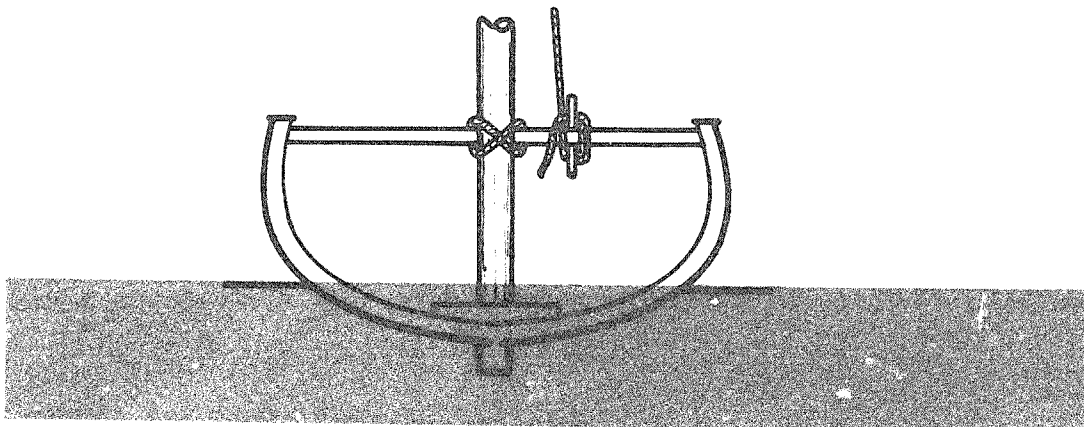

## 8.7. Steering

When sailing, the direction in which the boat is moving has to be controlled by steering. There are two methods of steering; the one you choose depends on the shape of your boat and how and where you use the boat.

A rudder is most easily fitted to a boat which has a *transom*, in other words, a flat back end. Rudders can also be fitted to double-ended boats where the *stern* is strong enough.

A steering oar is used when the boat cannot be fitted with a rudder, or when the boat is operating in shallow water or from a beach.

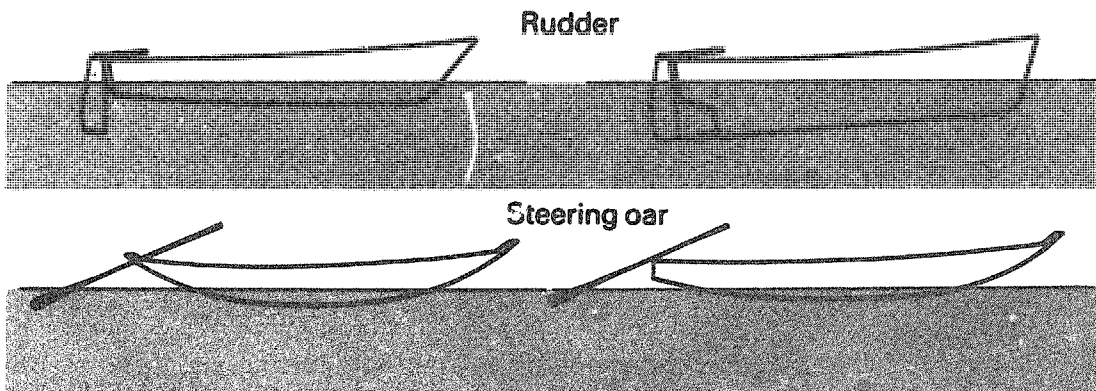

## 8.8. Rudder

The rudder is a vertical blade centrally fitted to the back of the boat. The fastenings are made from metal or rope which allow the rudder to turn from side to side. A rudder will not work unless the boat is moving forwards.

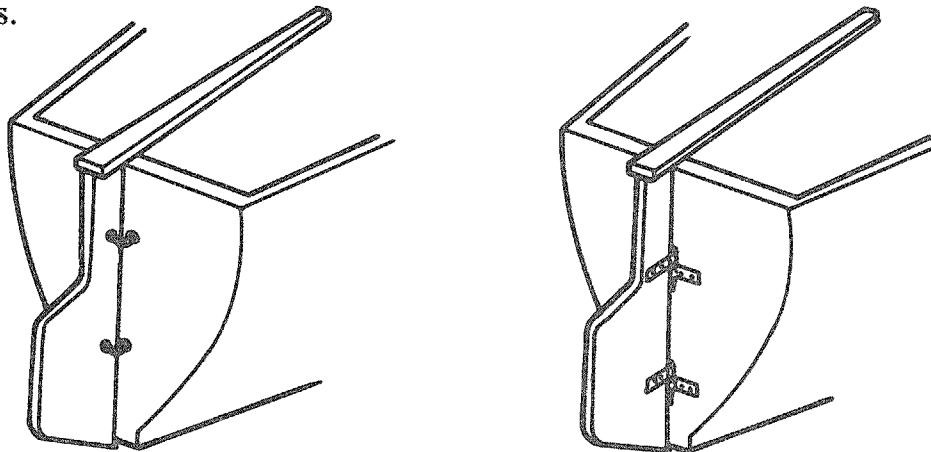

Metal fastenings are difficult to make and must be lined up correctly. Rope fastenings are easy to make but will need regular replacement.

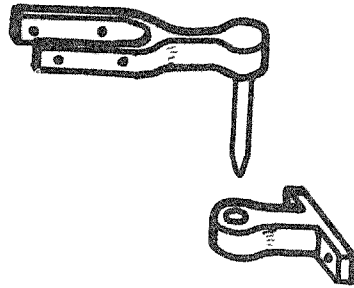

The size of the rudder is important. If the rudder is too big it will be difficult to operate and will slow the boat down. If it is not big enough or too shallow in the water, you may not have enough control.

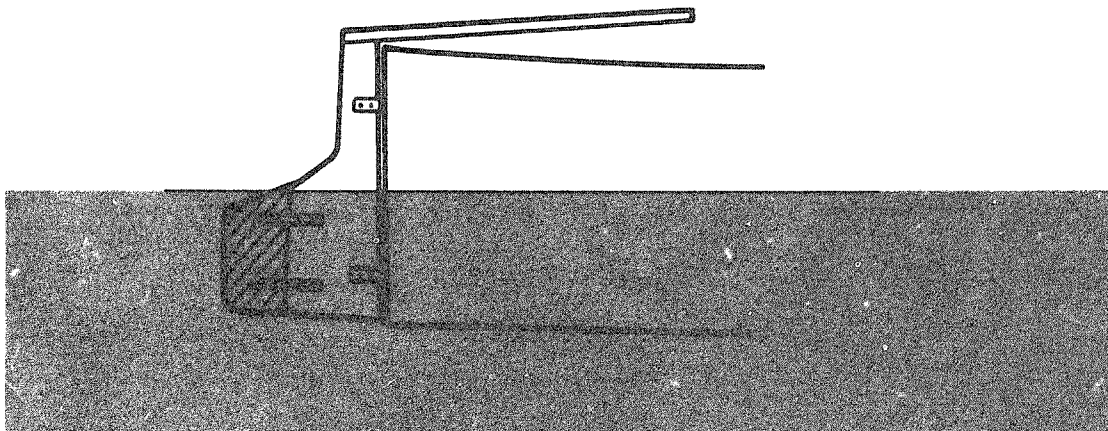

If your motor boat already has a rudder, when you fit a sailing rig you may need to make the rudder bigger.

The following table gives a rough guide to the area of rudders for different sizes of boat.

BOAT LENGTH (metres)	UNDERWATER AREA OF RUDDER (square metres)
2	0.13
4	0.22
6	0.31
8	0.38
10	0.45
12	0.5
14	0.56
16	0.6

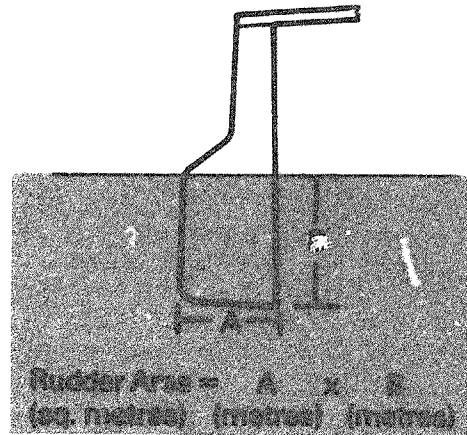

If your boat is launched from the beach, then a fixed rudder may not be a good idea as it can be broken in shallow water. An alternative is a lifting rudder.

Rudder down

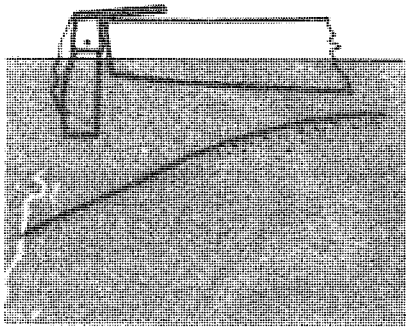

Rudder up

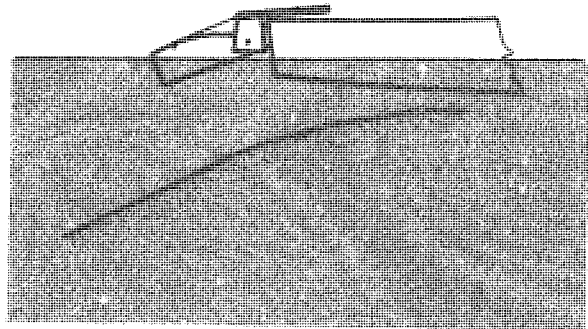

Boats with outboard motors may have the motor moved to one side to fit a central rudder, or can often use a steering oar.

If you are fitting a sailing rig to your boat for the first time and your boat does not have a rudder, then fit a steering oar as a first step. Once you have experience of your boat under sail, you may later decide to fit a rudder.

### 8.9. Steering Oar

A steering oar needs more skill and effort than a rudder but works well and is very easy to fit. The oar is loosely lashed at the back of the boat so that it may be twisted or turned in any direction.

The oar is used as a sideways paddle to turn the boat when it is slow moving or stopped. At speed, the oar is moved with a combination of twisting and sideways movement.

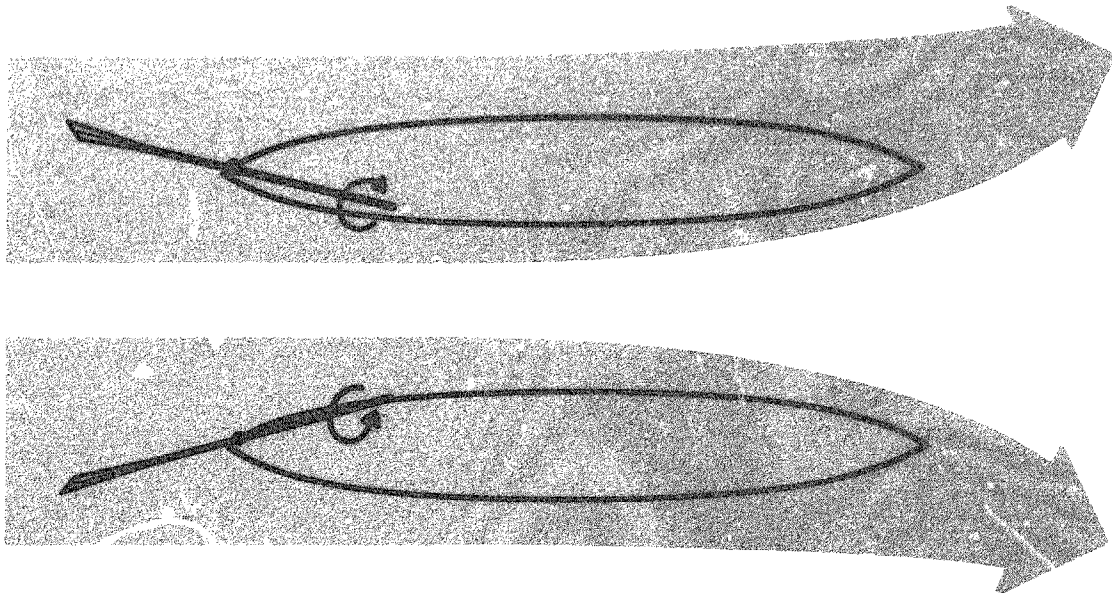

The oar should be made from light, strong wood. The drawing below gives the size of a typical oar for a boat of about 7 metres long.

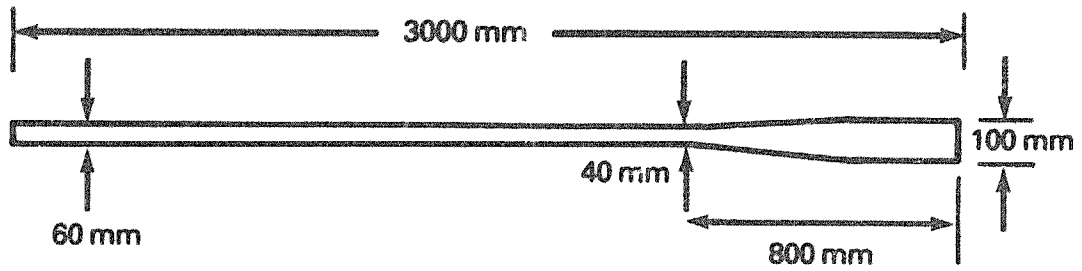

## 9. Making the Mast and Spars

### 9.1. Mast Selection

The obvious choice for a mast is a tree trunk, although other materials may be used. A good mast is strong, straight and not heavy. Most small boat sailing rigs need masts of between 3 and 7 metres in length. In many areas, lengths of wood between 3 and 5 metres are common; the size you can find will help you with the choice of rig it is possible to make.

Most species of tree are suitable for mast making. Among the best are Pine, Mangrove, Eucalyptus and some hardwoods. The suggested length of the mast is given in the Appendices, but before cutting the tree remember to add the depth of the boat to the length given.

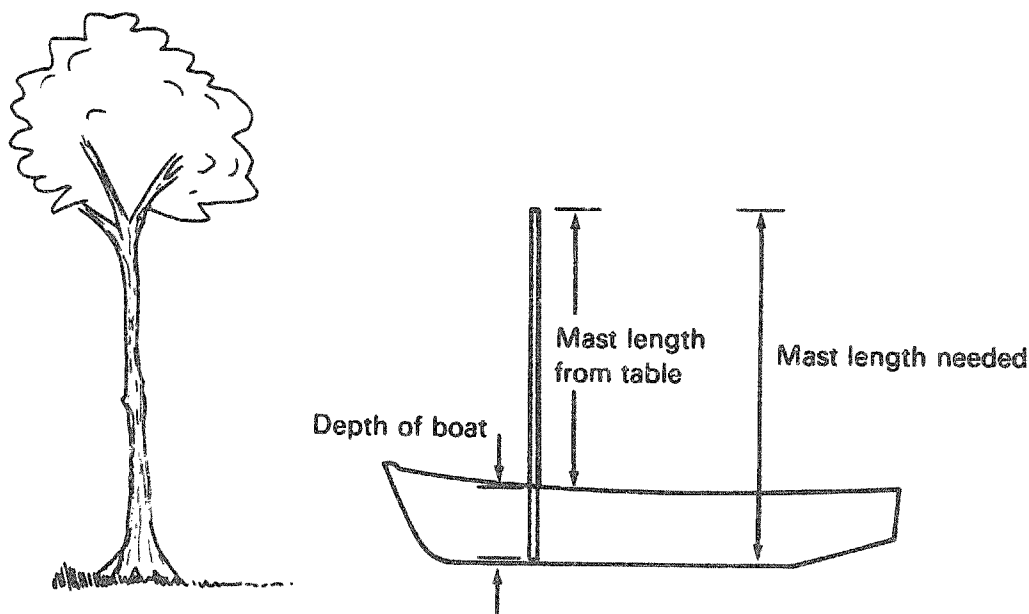

Wood is not the only material which can be used to make masts. If aluminium or steel tubes are available, they will be suitable if their weight and strength are about the same as a wooden mast would be. Generally, steel pipes are too heavy, but small tubes could possibly be used for masts on rigs like a Crab Claw or Lateen.



## 9.2. Wooden Mast Making

The selected tree should be cut down and the bark and branches removed. It should then be dried by leaving it, lying flat, for several weeks. This is important since the mast will not be strong or last very long if it is not properly dried (seasoned). Drying may cause shakes (splits along the grain) in some species of tree. These do not usually affect the strength of the mast.

Cut the mast to the correct length and trim it down to size as necessary. The diameter at the top should be about half the diameter at the bottom.

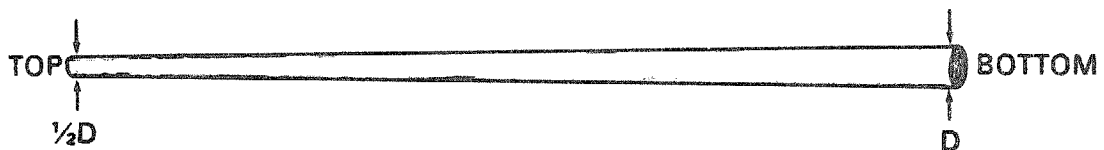

The base of the mast should be shaped as shown to form a strong end to fit into the mast step.

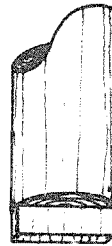

Fasten wooden *chocks* to the top of the mast as shown to support the rigging. These need to be strongly fixed. This method is better than holes which go right through the mast, as they will weaken it. *Deadeyes* for halyards are also fitted by chocks as shown in the Appendices.

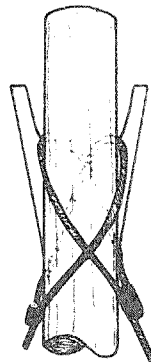

The mast is now ready for the rigging, and can then be fitted into the boat.

### 9.3. Spar Selection

Spars are the poles used to spread the sail area away from the mast. Each type of rig has different requirements, so the materials you have available will affect the type of rig you can make (see Section 4).

The best material is young hardwood trees, although any tree used for mast making is also suitable. Bamboo is also good, but may have to be replaced regularly.

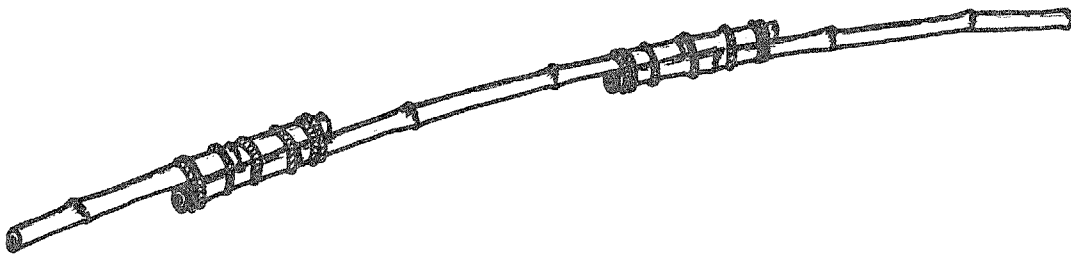

Several shorter lengths of wood can be lashed together to make a spar. This method is suitable for Lateen and Crab Claw where the spars are long. The Sprit rig needs a long spar which must be light and stiff. If it is not, it will bend in the middle and probably snap.

Other spars, such as those for Gunter and Dipping Lug rigs, are shorter and need to be strong to keep the shape of the sail. Some bend in the spar is a good thing as it gives the sail some flexibility in stronger winds.

The length of a spar can be worked out from the Appendices, or by making the sail and then cutting the wood to fit.

#### 9.4. Spar Making

The spar should be prepared and dried in the same way as the mast. The shaping of spars differs from rig to rig. On some rigs, the spar is thicker in the middle than at each end, whilst on others, the spar simply tapers from one end to the other. Usually, *booms* are the same thickness from one end to the other. The Appendix for your chosen rig will show the shaping and dimensions of spars.

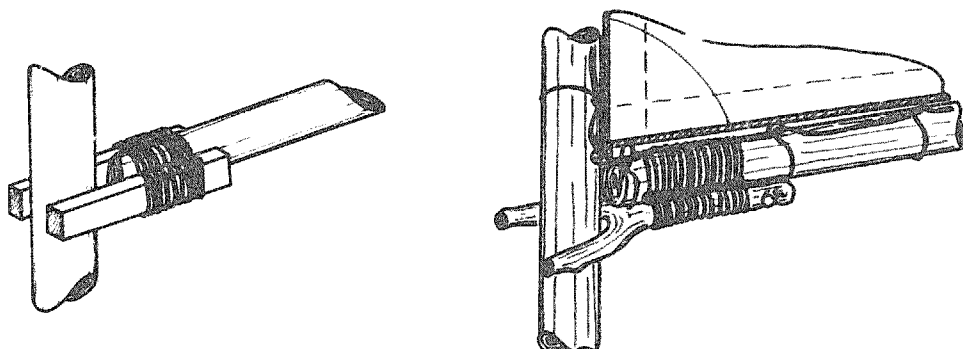

Some spars, mainly booms, need to turn around the mast. This is done by using a fork of a tree or wooden chocks lashed tightly to the spar. The boom is held in position against the mast using wooden blocks or rope.

## 10. Making the Rigging

### 10.1. Standing Rigging

Standing rigging is needed with most rigs to hold the mast up. Suitable materials are wire, steel rod, wire rope or rope. They need to be strong and not stretch too much.

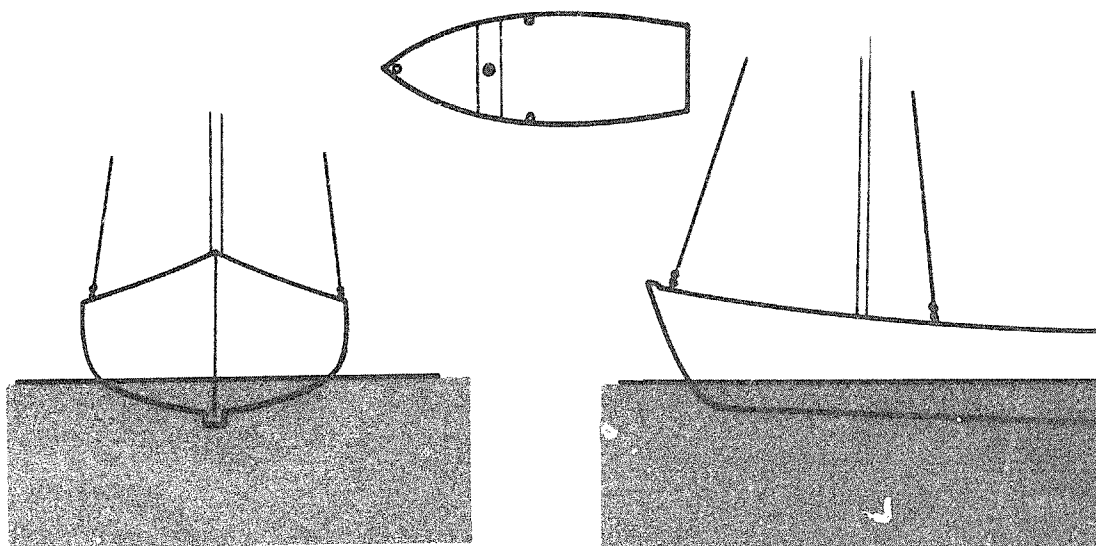

The standing rigging is attached to the boat at (usually) three points. The approximate positions are shown above. The side stays must be behind the mast.

The rigging should be attached to the mast with a loop around the top of the mast. This loop is *spliced* (see page 56) or *seized*, and held in place by wooden chocks fitted to the mast.

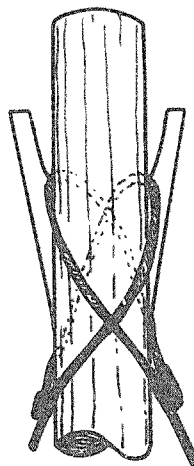

To hold the mast up properly, the rigging must be pulled very tight. This is done by using deadeyes and a thin line called a *lanyard*. The rigging is *made fast* round a circular wooden block (the deadeye) which has three holes bored in it. Another deadeye is made fast at the attachment point on the boat. The lanyard is laced through the holes in each block, pulled tight and tied – this makes the rigging very rigid.

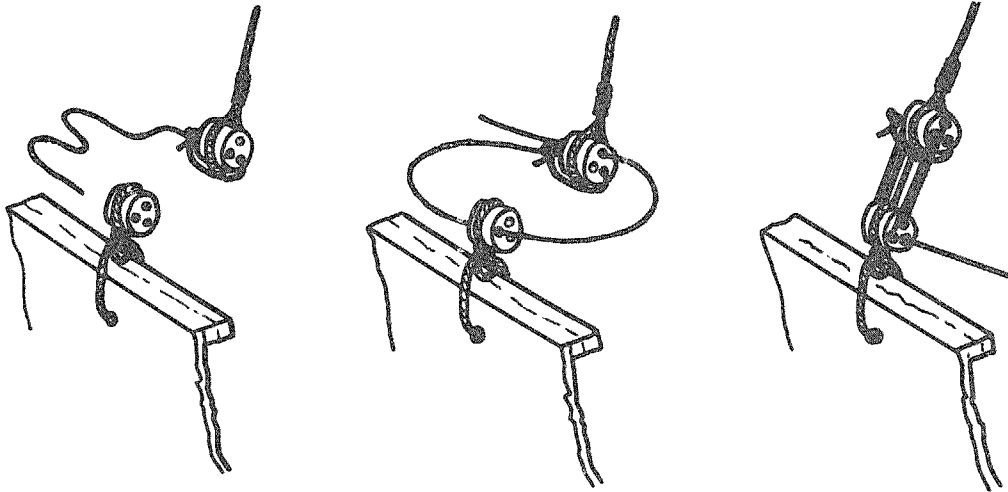

When cutting the rigging to length, remember the following things:

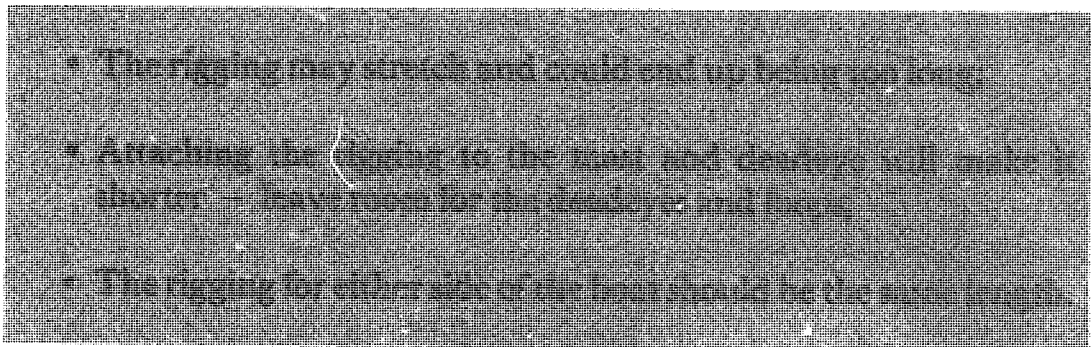

Metal rigging can be welded or mechanically fastened. It needs careful inspection, as corrosion will weaken it. Wire rope should be spliced and needs oiling to prevent rust.

## 10.2. Running Rigging

All the ropes needed to control the sails are known as *running rigging*. These are halyards, *sheets* and other *control lines*.

Rope is made from many different materials. Some are man-made 'plastic' ropes such as polypropylene or nylon; others are made from natural fibres. Man-made ropes stretch more than natural fibre and slowly break down in sunlight, becoming stiff and weak in time. They also break quickly if rubbed in one place by a sharp corner (*chafe*). Natural fibre ropes shrink when wet and swell in size, sometimes jamming deadeyes.

Suitable sizes for running rigging are shown in the Appendices but you will have to see what is available in your area. A disadvantage with thin rope is that it is difficult to hold.

Pulling a rope can be made easier by using a looped system as shown below. The more times the rope runs back and forward, the easier the rope is to pull. Deadeyes should be used so that the rope runs smoothly. This system is known as *purchase*.

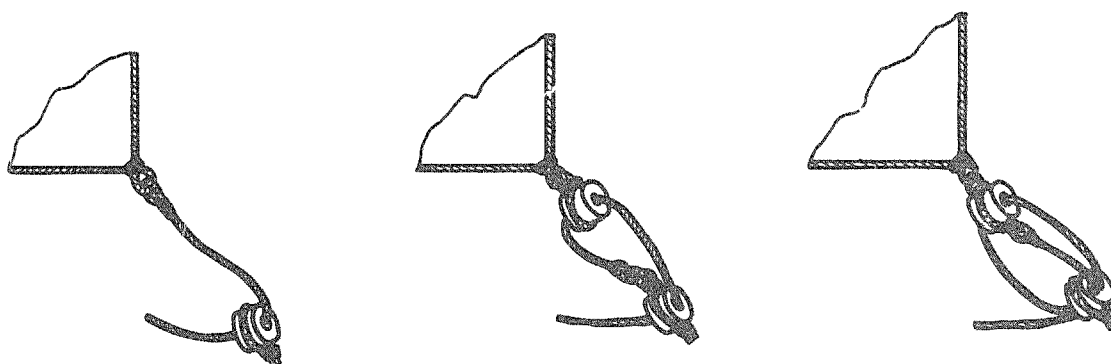

### 10.3. Splicing and Seizing

A loop in a piece of rope or wire can be made by splicing or seizing.

Splicing involves opening up the strands in the end of the rope, then threading them back through the rope.

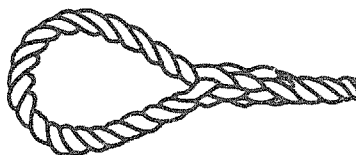

Seizing simply involves tying the rope together with twine or thin rope. It is not as strong as splicing, but a lot easier to do.

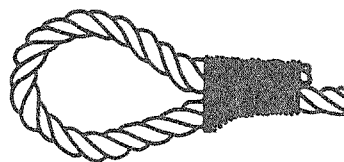

### 10.4. Stepping the Mast

Once the standing rigging and any halyard deadeyes have been attached to the top of the mast, it can be put up or 'stepped' in the boat. Make sure the foot of the mast fits tightly into the mast step and is supported by the deck or cross-member. Connect the standing rigging to the boat and tighten it so that the mast is not straining the cross-member.

You are now ready to attach the spars and make the sails.

## 11. Making the Sails

This chapter will show you how to make sails with either three or four sides. Having chosen your rig, you will need to read this chapter together with the Appendix of your chosen rig (Appendices 3 to 8).

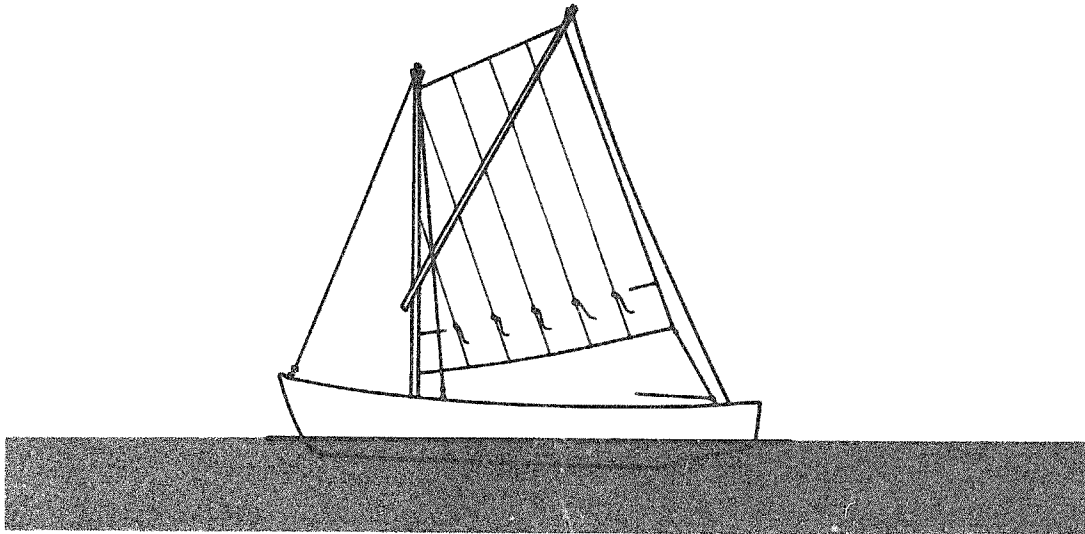

The quality of the sail material and the standard of workmanship when making the sails will both affect the performance of the boat when sailing. When finished, the sails should be maintained as well as local conditions will allow. Sails which are looked after well will last much longer and perform much better.

### 11.1. Selection of Materials

(a) Terylene cloth is the most stable material for workboat sails, but is often not available and is expensive. Man-made fibres tend to be broken down in sunlight, so a terylene sail is not necessarily long lasting. The thread used to sew the sails does not sink into terylene cloth so may be damaged by chafe; broken thread needs replacing quickly to stop the sail coming apart.



(b) Nylon cloth is suitable for small sails of less than 8 square metres. It stretches too much to be used for larger sails.

(c) Cotton cloth varies considerably in quality – generally the more seeds (black spots) you can see in the raw cloth, the lower the quality. The strength of the cloth depends on the length of the individual fibres in the strands which make up the cloth (the staple length). The longer the fibres, the stronger the cloth. Many cotton cloths are not woven tightly enough to hold the wind. You can find out by blowing through a sample and feeling the amount of air passing through. Many close-woven drill-type cottons are suitable for sailmaking; it is better to buy it in the raw state (before it has been dyed). Cotton rots if left wet and is also stiff and difficult to handle when wet. Thread sinks into the cloth, so does not rub against standing rigging.

(d) Flax cloth is generally stronger than cotton but does stretch more. It is easier to handle when wet, but is heavier so is more suited to larger sails. Flax is easily grown and is often available. Finished sails should be treated as for cotton to prevent rot and deterioration (see 'Maintenance', page 72).

(e) Polypropylene or polyethylene reinforced plastic sheet is often available and can be used for small *craft* sails. The material is stretch-resistant and holds reasonable shape when made into sails, though frequent folding and exposure to sunlight will reduce life. Sails made from plastic should last up to 6 months.

All sail cloth is available in a variety of widths. Cotton and flax cloths should be bought as wide as possible and *false seamed* (see page 62) to maximum 500 mm widths.

(f) Thread. All sailmaking should be carried out with nylon/terylene thread for machining, regardless of the sail cloth in use. Linen thread may be used, particularly for hand sewing, but cotton thread is to be avoided due to its lack of strength and poor resistance to rot.

Where possible, sailmaking should be done by machine to give regular seams and good finished shape. Ordinary domestic sewing machines, foot or hand powered, are satisfactory for small boat sails up to 20 square metres in area.

## **11.2. Sailmaking**

A large, flat area is needed for laying out and sewing the sails. Ideally, the sailmaking site should have:

- a floor surface big enough to spread out the largest sail full size. The best floor surface is wood, so that the cloths can be laid out and held in place by spikes or nails. If earth or cement are used, the surface should be as smooth as possible;
- shade from the sun and protection from rain and wind;
- the sewing machine positioned close to the sailmaking floor, with space around it to allow for handling of large areas of cloth.

### Tools needed for sailmaking.

- Sewing machine, spare needles, size 18 to 25.
- Nylon, terylene or linen thread.
- Hand-sewing *palms*. See note below.
- Selection of sail needles, sizes 14 to 18. See note below.
- Hollow *fids* for splicing. See note below.
- Scissors and a knife to cut cloth.
- Chalk for marking floor and cloth.
- Tape measure, at least 10 metres long.
- *Battens* to mark curves, as long as the longest side of the sail.
- Straight edge, 3 to 5 metres long, steel or hardwood.

### NOTE:

- A *hand-sewing palm* is made of thick leather. It is worn on the hand when hand-sewing sails and protects the hand when pushing needles through sailcloth. If palms are unavailable, use a block of wood, although this is not as convenient.
- Sail needles are made from hardened steel; they need to be strong, as sailcloth is tough and needs a lot of force to sew.
- A hollow fid is used for opening up a rope to make a hole for splicing, or to allow a smaller piece of rope to pass through. If a fid is unavailable, use a piece of steel or brass pipe of 25-40 mm diameter, cut at an angle like this:



### Making the sails

To make a sail you need 30% more sail cloth than the area of the sail to be made. The extra is to allow for making the strengthening pieces at the corners and edges. Little is wasted.

For simplicity, the making of sails can be divided into eight steps:

**STEP ONE.** Draw out the shape of the sail on the ground by marking each of the corner points and joining them with straight lines. The lines can be ropes or chalk marks but must be permanent enough to remain for the two or three days required to make the sail. You now have the plan.

To draw the plan of a three-sided sail you need only the lengths of each side; for a four-sided sail you need the four lengths and one diagonal length. Always start by drawing out the diagonal.

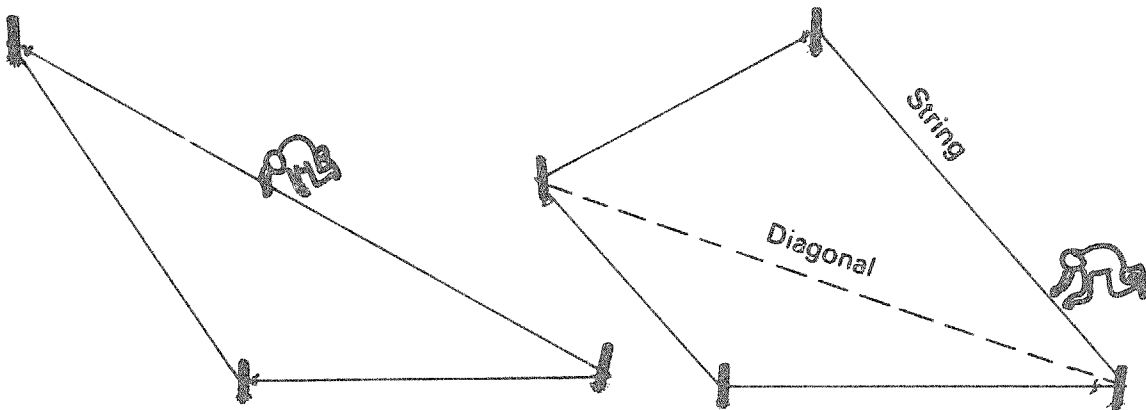

Check that the shape laid out looks generally the same as the shape of the sail shown in the Rig Description Appendix 3 to 8.

**STEP TWO.** Lay the cloths on the plan; start with the *leech* or back edge of the sail, which should lie exactly on the marked line. Lay each cloth parallel to that edge, overlapping each other by about 80 mm, and overlapping the top and bottom by about 150 mm.

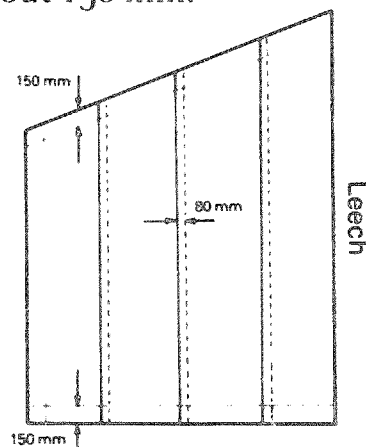
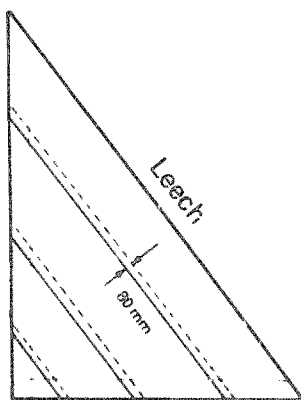

**STEP THREE.** Each of the cloths is now ready for false seaming. This means stitching folds into each cloth from top to bottom. The distance between these folds should not be more than 500 mm. False seams reinforce the sails and help them keep their shape.

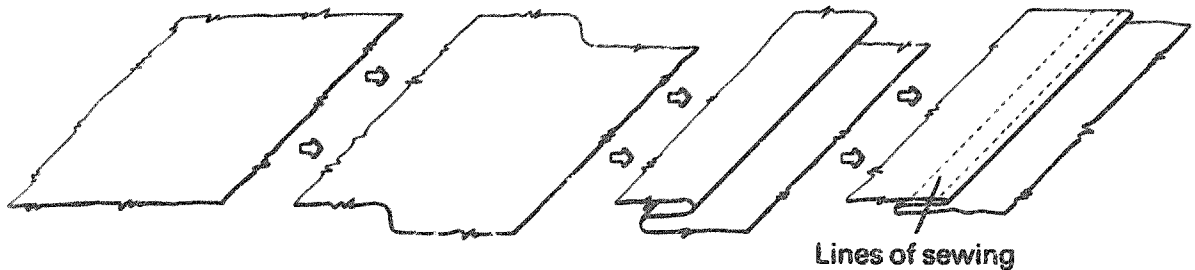

Starting from the leech edge, take each cloth in turn and false seam it every 500 mm, laying the cloths back on the plan after they have been false seamed. Leave an overlap of about 50 mm between cloths.

**STEP FOUR.** Keeping the 50 mm overlap, join up the cloths by sewing them together like this:

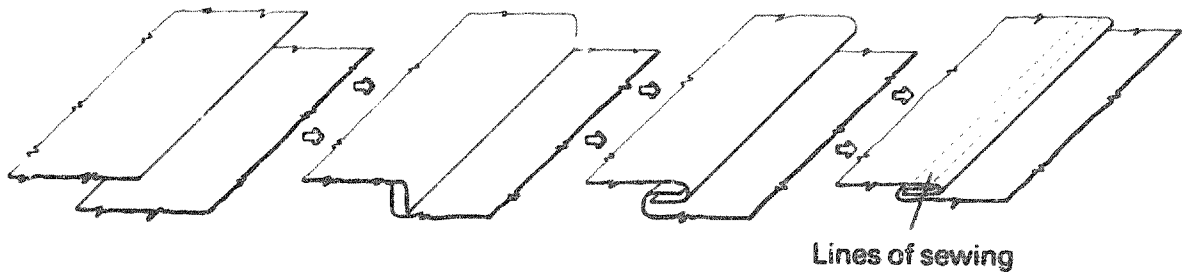

When all the cloths have been sewn together, they should form a rough 'sail'. This should overlap the plan by about 150 mm except the leech edge, which should lie exactly on the plan line.

**STEP FIVE.** Take a batten and a marker and mark out the curved edge shapes of the sails like this:

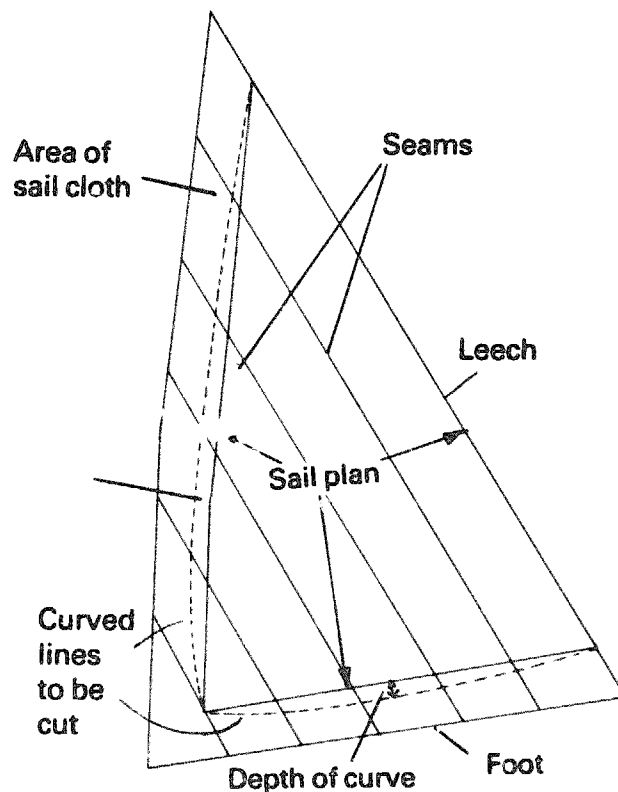

**NOTE:** All sail edges are curved except for the leech which is straight on all rigs. The only exception to this is the Crab Claw, which has a curved leech. See the Appendix of your chosen rig.

The curves will put shape into the sail and increase the power you will get from it. Too much curve will make a sail which will not work when sailing towards the wind. Too little curve will result in a flat sail with little power.

The curve required for each edge of the sail may be read from this table. Note that there is no curve in the leech of any sail, except the Crab Claw.

LENGTH OF SIDE OF SAIL (metres)	DEPTH OF CURVE (millimetres)
2	50
3	75
4	100
5	125
6	150
8	195
10	240

The table refers to all sails except the Crab Claw. The dimensions for Crab Claw sails will be found in Appendix 4.

Using scissors, cut exactly along the marked lines, keeping the strips of cloth which you cut off.

**STEP SIX.** Using offcuts of cloth, cut out the corner strengthening patches. You will need two for each corner of the sail, as shown, and two for each reef point. The patches need to cover 500 mm each side of the sail.

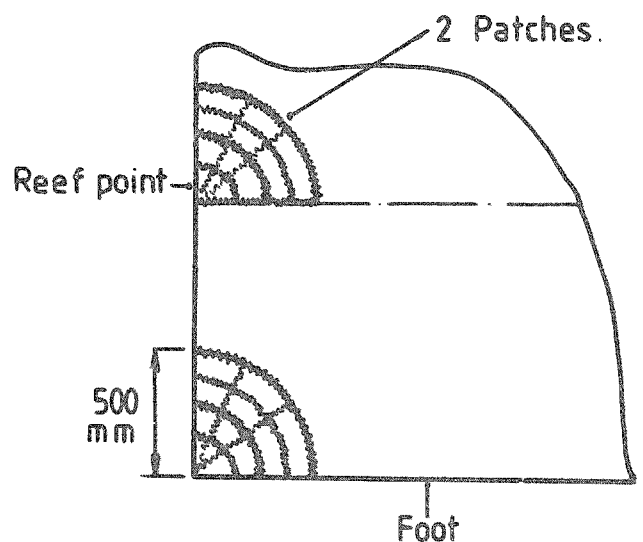

Sew the patches onto the sail to match the edges already cut.

**STEP SEVEN.** Take the strips of cloth which were cut off when shaping the edges of the sail. Fold them over to lose the cut edge, and sew them along all the sail edges, sewing through the corner patches.

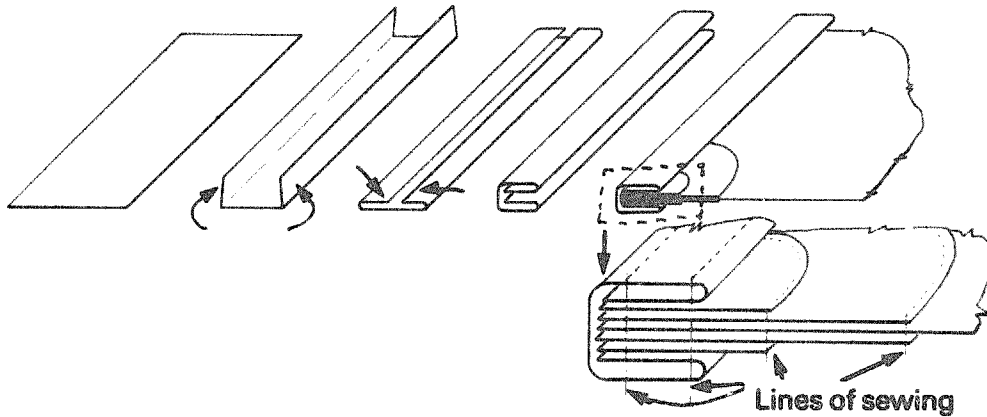

Make sure that the strips follow the pre-cut edges of the sail, so as to keep to the curves which were marked out in Step Five.

**STEP EIGHT.** The sail is now ready for roping. Rope is sewn continuously along the mast edge of the sail and along the edges which will be laced to spars.

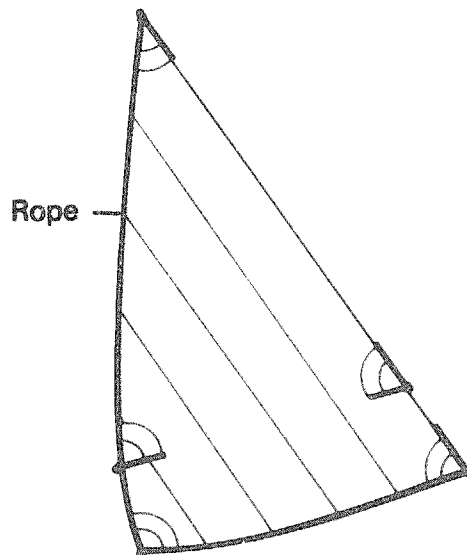



Before being sewn to a sail, the rope is stretched for several hours and all kinks removed. The rope is then stretched again between two uprights, and the edge of the sail held to it with stitches, every two metres. Note that you start in the middle of the rope, with the mast edge of the sail.

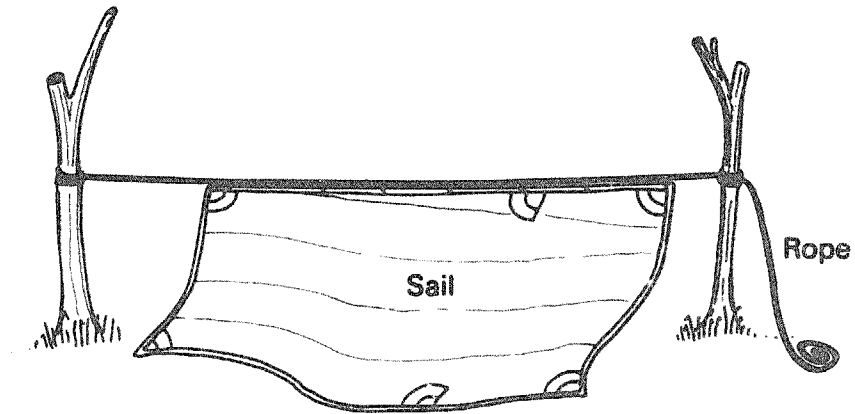

Following this, the rope is sewn to the sail using one stitch to each lay of the rope, keeping the upper edge of the rope level with the sail edge. Make sure the rope does not twist.

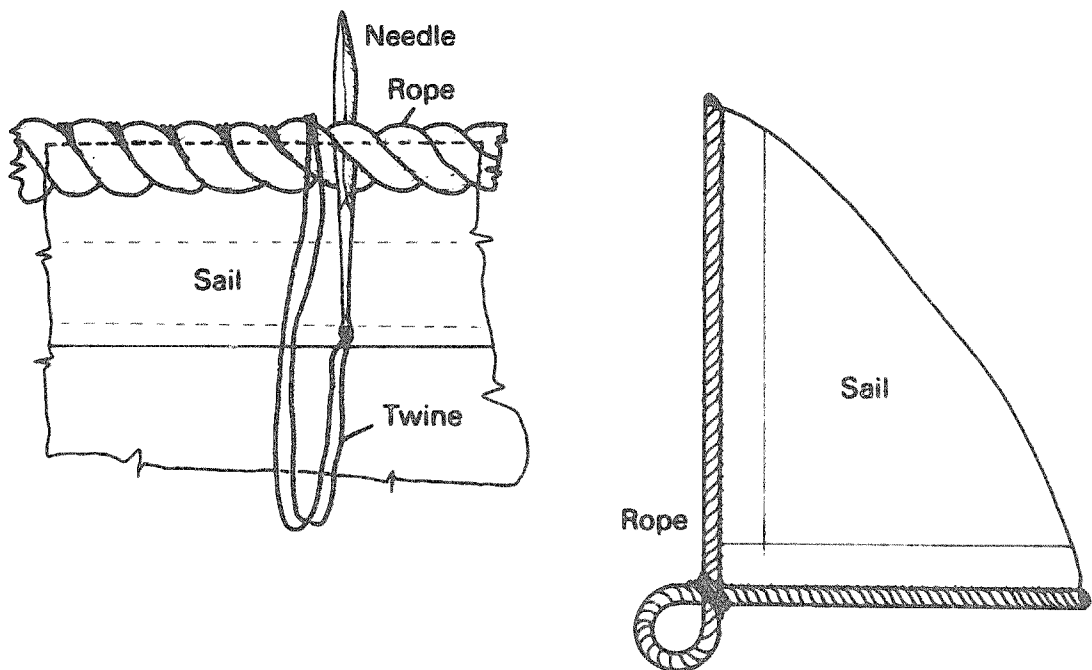

At each corner of the sail, the rope is left in a loop which is seized and sewn in.

At corners without edge roping, such as the *clew*, a short rope is sewn on which extends beyond the reinforcing patches. This rope has a loop which is seized and sewn in.

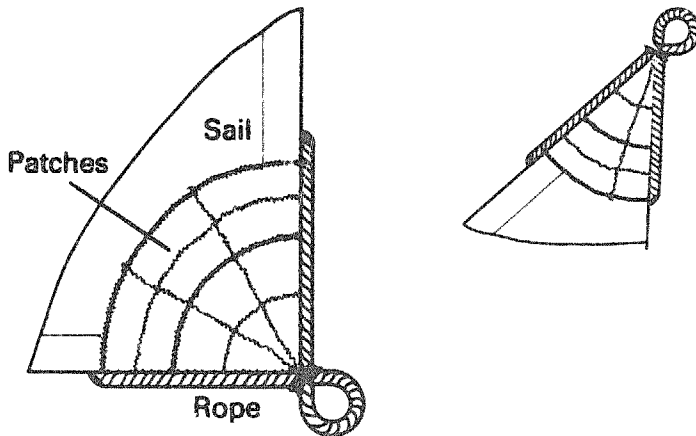

The rig drawings in Appendices 3 to 8 show the reef points for each particular sail. Reef points are needed to tie up the loose part of the sail when the area must be reduced in a strong wind. At the place on the edge of the sail where a reef point is shown, a short length of rope is sewn on as shown in the drawing. Once again, a loop is seized and sewn in.

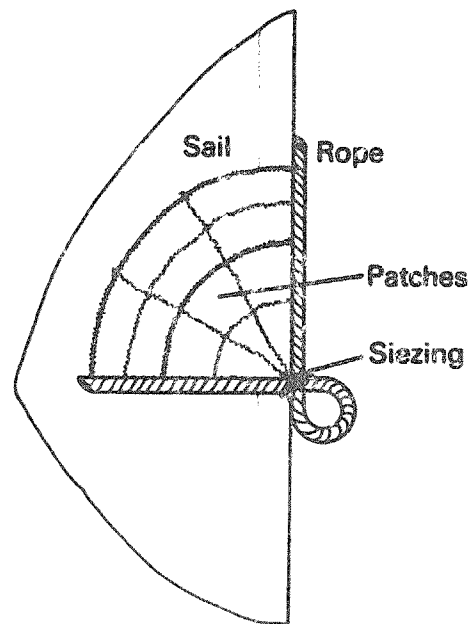

Across the sail in line between the reef point and the front edge, small patches are sewn over the seams. They are sewn on in the same way as corner patches. Make a small hole through both the patches and the sail, and sew around the edge of the hole to prevent tearing the sailcloth. A thin line about 500 mm long is passed through the hole and knotted on each side of the sail.

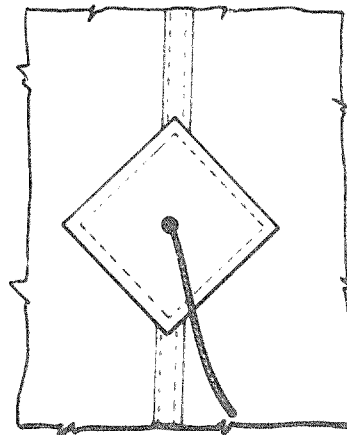

The sails are now complete and ready to be put onto the boat.

It is worth remembering that:

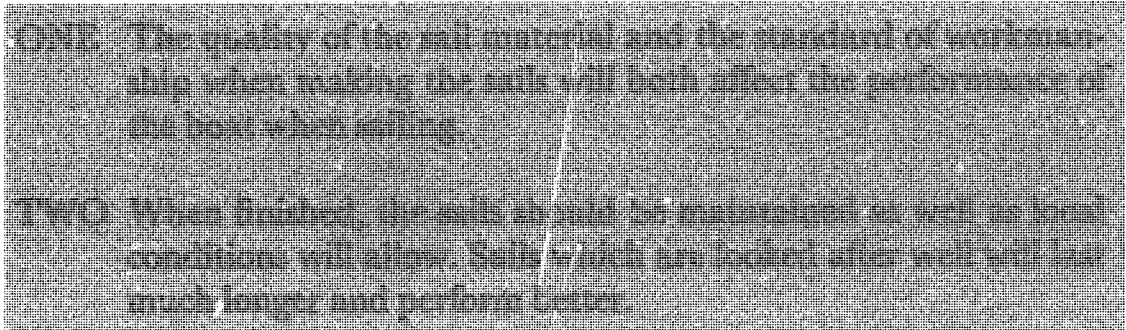

Sail maintenance is explained fully at the end of the next chapter.

## 12. Attaching and Hoisting the Sails

Once the sails are complete they must be attached to the mast and spars as appropriate. This is done by *lacing*. There are two methods of lacing; one for the spars, where the sail is permanently attached, and the other used on Sprit and Gunter rigs to enable the sail to slide up and down the mast.

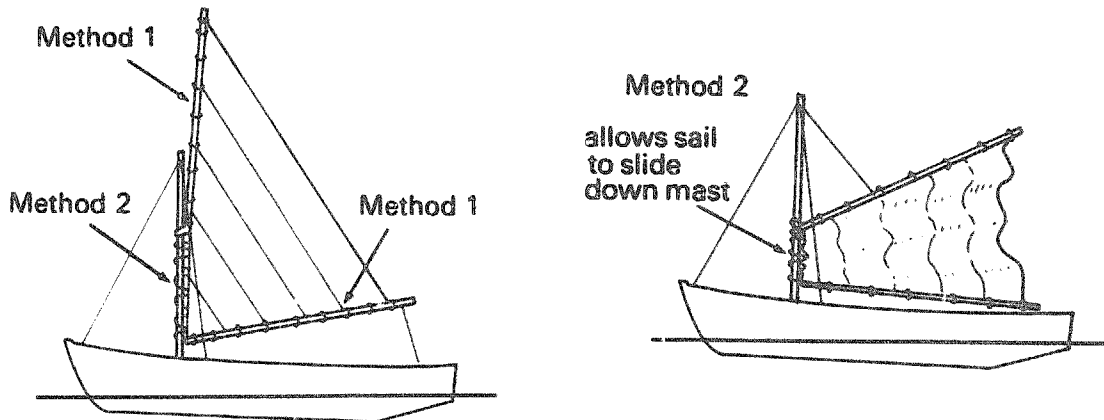

### Lacing – method 1

This method of tight lacing is used to permanently attach sails to booms or spars.

Start with a piece of line or cord which is one and a half times as long as the side of the sail to be laced. At one end, attach the line to the corner of the sail and pass it around the spar and back through the corner hole, pulling the line tight. About 300 mm along the sail edge, thread the lacing line under one strand of the edge rope, around the spar, and back through itself, as shown below.

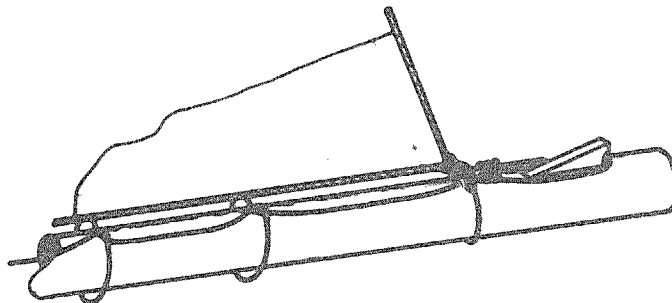

This is repeated at equal intervals along the spar. At the end of the sail edge, the line should be pulled tight and tied to the corner of the sail.

At either end of the sail edge, a short line is attached to the corner of the sail, pulled tight, and tied to the spar. This keeps the edge of the sail tight along the spar. See picture on page 71.

### Lacing – method 2

This type of loose lacing is used where a sail is to be pulled up and down the mast and needs to slide easily.

Start with a piece of line or cord which is twice as long as the side of the sail to be laced. At one end, attach the line to the corner of the sail. About 300 mm along the mast, thread the lacing line round the mast, under one strand of the edge rope, and back on the same side of the mast. A further 300 mm along, repeat this on the other side of the mast as shown below. The process is repeated until the whole sail side is laced to the mast.

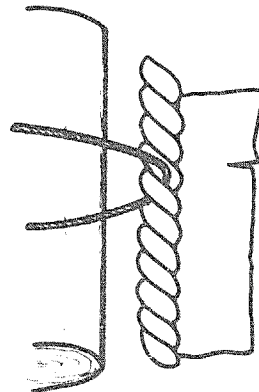
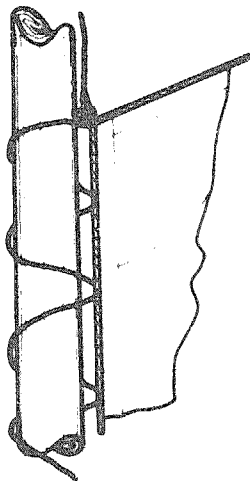

Care should be taken that the lacing is loose enough to allow the sail to slide, remembering that the mast is thicker at the bottom than at the top.

## Halyards

If the sail and spar are large and heavy, two blocks will be needed to make pulling the sail up easier. This method is described in more detail in Section 10, and is shown below.

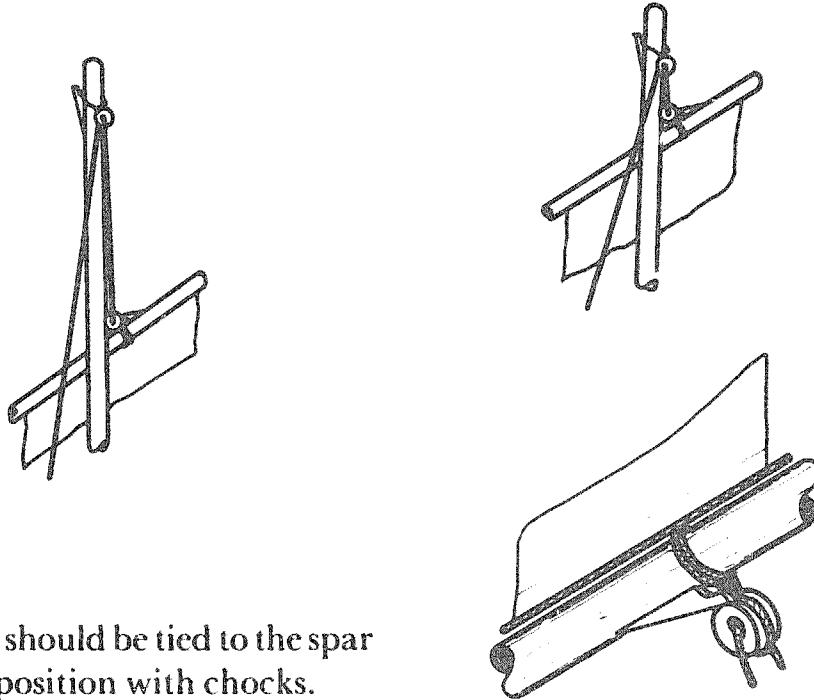

The halyard should be tied to the spar and held in position with chocks.

Halyards and sail corners should be tied to the spar, as this method does not reduce the strength of the spar. Wooden chocks fitted to the spar will stop the rope slipping and help to position it each time the sail is hoisted.

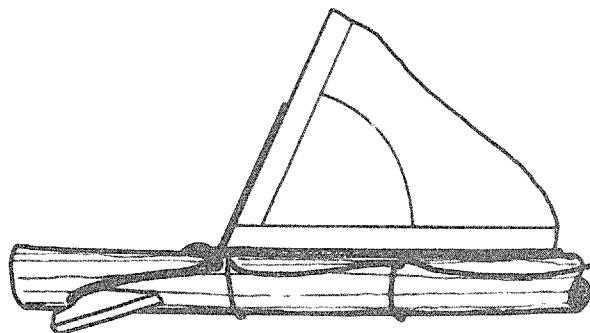

**Maintenance of sails**

Sails should be looked after as well as possible. Sails which are well-maintained will last much longer, and will perform better.

Man-made sailcloth, such as Terylene, tends to break down in sunlight, so sails made from this material should be covered when not in use.

Natural materials, such as cotton or flax, will rot if left wet; salt water makes this problem worse.

Whenever possible, therefore, remove all sails from the spars and wash them in fresh water. They should then be left flat to dry. When dry, they should be folded and then stored in a dry place.

## 13. Testing and Sea Trials

Before going to sea for the first time, it is essential that the boat with sails fitted is thoroughly tested. To make sure that the rig works correctly and safely:

- Launch the boat in calm conditions and check for leaks;
- With the crew on board, check that the boat does not roll too easily or too slowly, which may happen if the mast is too heavy;
- Test the strength of the rig by straining the mast and checking the rigging attachment points on the boat. It should be possible to tip the boat over by pulling on a halyard to the top of the mast from outside the boat;

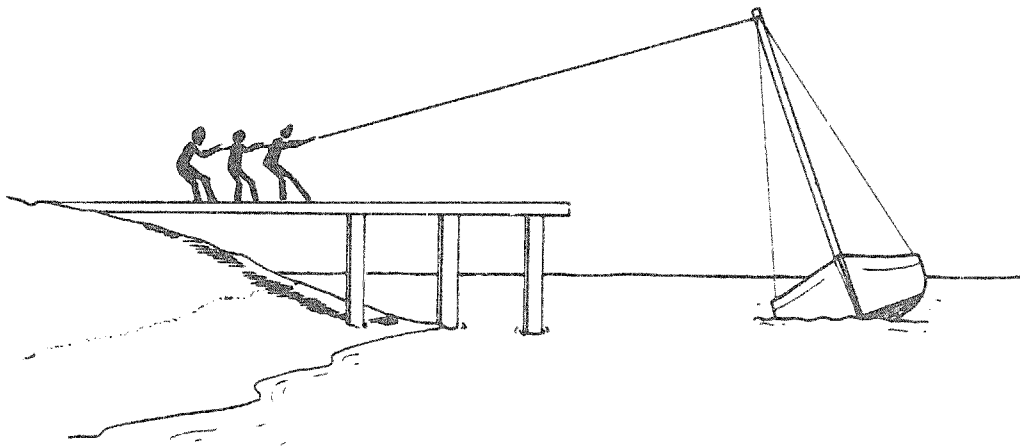

- Raise and lower the sails to check that halyards and sheets move easily, and that any lacing methods work correctly;
- Check the fit of the sails. Adjust to avoid wrinkles or bagginess;



- Try the rudder or steering operation. Make sure it does not get in the way of sailing or fishing gear;
- Now try sailing in a light wind. Is the boat stable? Does the strain on the rig cause the hull to leak? Can the boat be steered easily?
- Try sailing with both more and less crew and gear;
- Is the sail too large – or too small – for comfortable sailing in average winds?
- Practice *reefing* and controlling the sails in stronger winds.

It must be possible to control the rig and the steering in all conditions. The boat must not have too much sail, so that there is a danger of capsizing.

The first fishing trips should be in company with other boats while fishing methods are worked out. The steadier movement and increased safety of the sailing craft will soon become apparent.

Long, offshore trips should not be made until the crew has confidence in the rig, and can handle it safely. Remember that the wind may drop, or blow from the wrong direction, so engine or paddles may still be needed.

## 14. Performance Monitoring and Log Keeping

Having installed sail on some fishing boats, it is a good idea to record their performance to check that the savings which we worked out in Chapter 5 are in fact being made.

Write down fuel consumption and catch per trip during a whole season. Compare this with similar boats, or the same boats before conversion. Note whether boats with sails catch more or less fish, and whether they make more or less trips per year. At the same time make a note of wind and sea conditions.

All this information can be easily written into a table like the one shown below. If it is filled in at the end of each day's fishing, it will have enough information at the end of the season to make comparisons simple.

Date :						
Boat :						
Crew :						
Wind direction :						
Wind speed :						
Sea state :						
Hours :	engine :					
	sail :					
	fishing :					
Fishing :	area :					
	catch :					
	dozen :					
	value :					
fuel :	used :					
	lost :					
Repairs :						
	cost :					
Remarks :						

This example shows the sort of table which will give enough information at the end of the season to work out any savings that have been made.

# **APPENDIX 1 – GLOSSARY OF TERMS**

**Ballast**

Weight to give the boat stability. Usually metal or stones placed low down or on the keel.

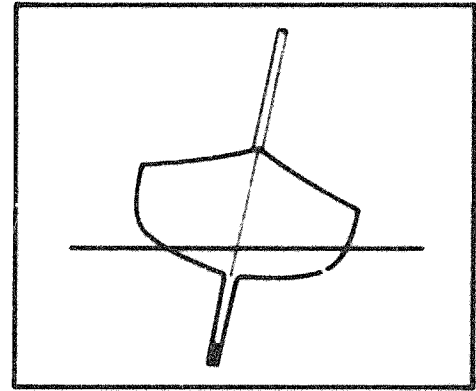
**Batten**

Flexible strip used to draw curves when cutting out sails.

**Beam**

The width of the boat at the widest part.

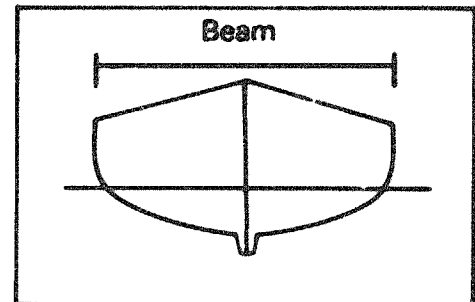
**Beaufort**

A scale of wind speed from 0 to 12.

Force 0 = no wind

Force 3 = light wind

Force 6 = strong wind

Force 8 = gale

Force 10 = storm

Force 12 = hurricane

(see Conversion Table, page 134).

**Belaying Pin**

Pin to which a halyard is tied. A cleat does the same job.

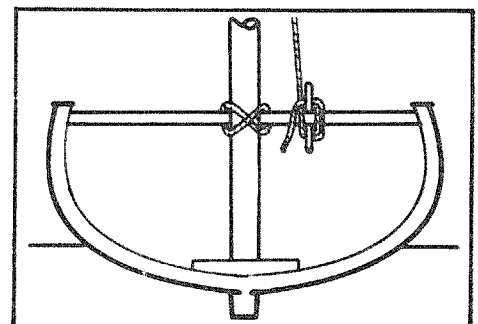

**Boom** a) A spar along the bottom edge of a sail. Used on Gunter rigs.

(b) A spar used when sailing away from the wind, to spread the sail. Tied to the lower back corner of the sail and pushed out from the boat in Dipping Lug or Sprit rigs.

**Brailed** A sail which is folded up when not in use by means of a rope. (See page 199.)

**Capsize** To turn the boat over on to its side, or upside down (usually by accident).

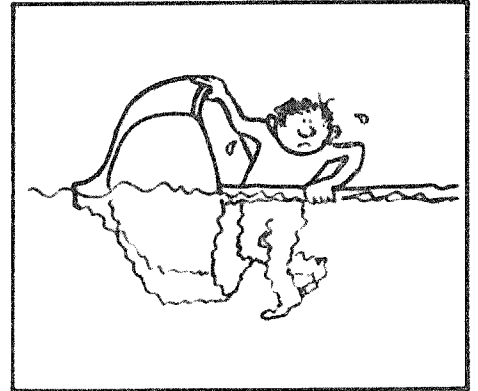

**Caulking** Cotton or other material inserted between the wooden planks of a boat to make them water-tight.

**Centreboard** A flat board sticking down into the water in a slot built into the centre of the boat. Can be raised and lowered. Stops the boat slipping sideways when sailing.

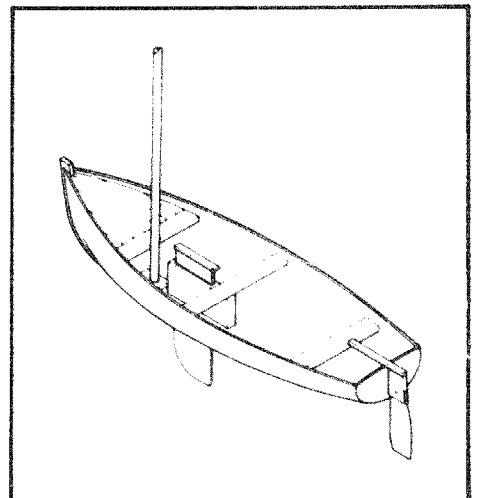

**Chafe** Wearing out of ropes or sail cloth, usually by rubbing round or over a sharp corner.

**Chock** A piece of wood used to position or hold firm a rope or another piece of wood.

**Cleat** A device for securing a rope such as a halyard. The rope is wound round the cleat, which prevents it moving or slipping. See also *belaying pin*.

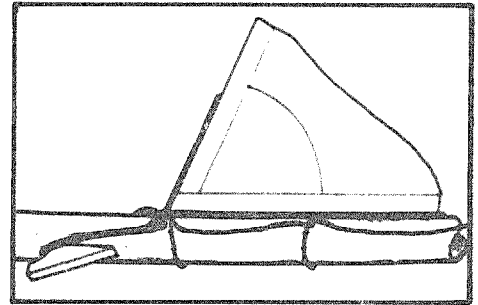

**Clew** The back lower corner of the sail.

**Control Line** A small rope used to adjust the position of a sail or spar.

**Craft** A boat.

**Crew** The people needed in the boat for sailing and fishing.

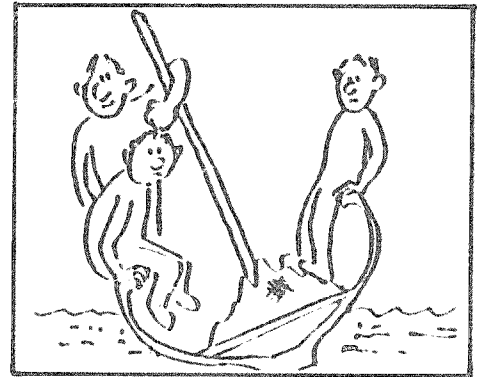

**Cross-Member** A piece of wood fixed across the boat, usually used for supporting the mast see thwart .

**Deadeye** A circular piece of wood with a hole or holes through it, used as a turning point for a rope.

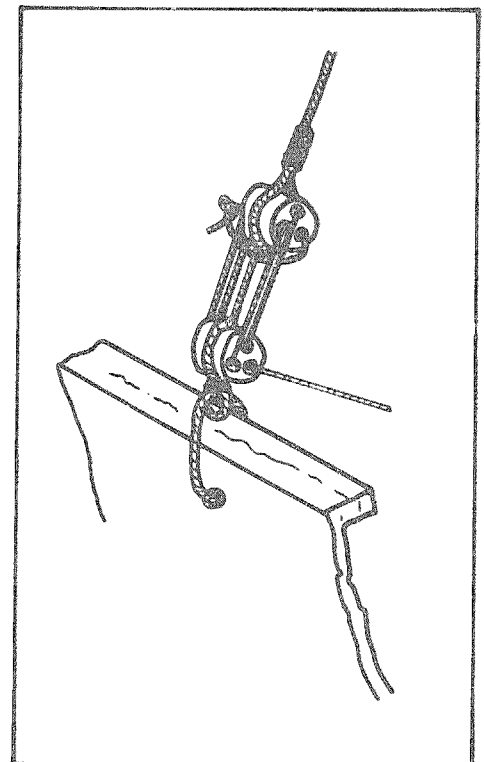

**Deck** Structure covering the top of the hull.  
May cover all or part of the boat.

**Downwind** Away from the wind.

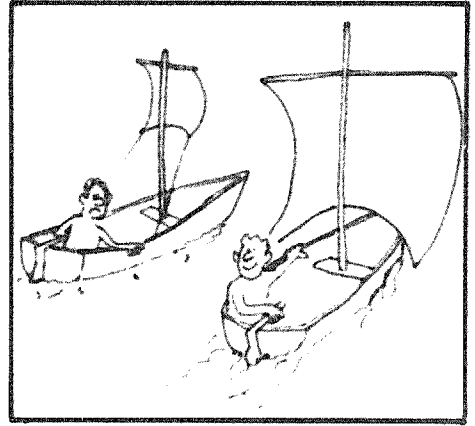

**False seams** Strengthening seams sewn along the length of a piece of sail cloth. Helps the sail to keep its shape.

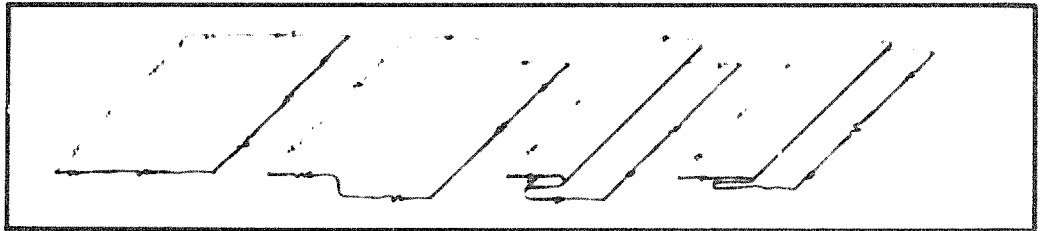

**Fastening** A nail, bolt or screw used when building a boat.

**Fid** A tool used in rope work. Used for opening up a rope to make a hole for splicing, or to allow a smaller piece of rope to pass through.

**Forestay** Part of the standing rigging which goes from the top of the mast to the front of the boat.

**Frames** Wooden ribs, inside the boat, to support the planking.

**Gybe** Turning the boat round whilst pointing away from the wind.

**Halyard** A rope which is used to pull the sail or spar up.

**Hand-Sewing Palm** See Palm.

**Heel** To lean the boat over.

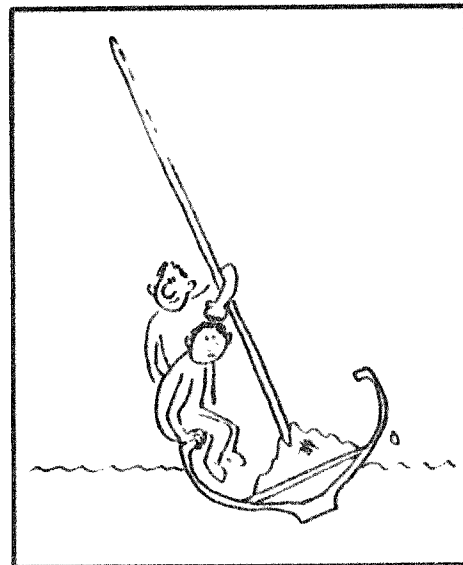

**Hull** The outside structure of the boat.

**Jaws** Pieces of wood used to position a spar.

**Jib** A small triangular sail which can be set in front of the mast. Also called a headsail or jib (see Appendix 8).

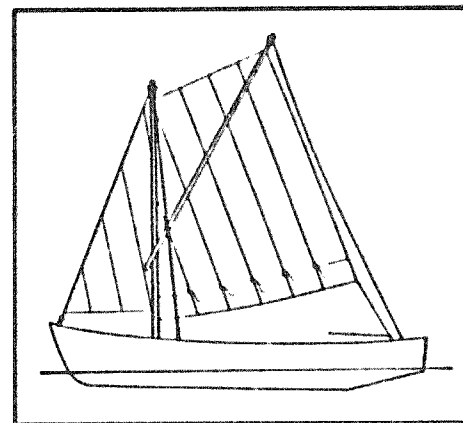

**Keel** The part of the boat under water. Stops the boat slipping sideways when sailing.

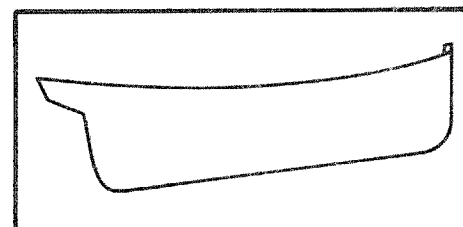

**Knee** Wooden block used as support or reinforcement.



- Knot** (a) Method of joining two or more ropes together.
- (b) A measure of the speed of a boat or the wind. 1 knot equals 1 nautical mile per hour (see Conversion Table, page 134).

- Lacing** A thin rope for attaching the edge of a sail to a spar.

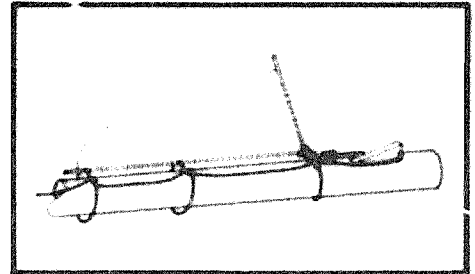

- Lanyard** A short rope used to attach one thing to another.

- Lash** To join or hold two things together using rope.

- Leech** The back edge of the sail.

- Leeboard** A flat board sticking down into the water, attached to the side of the boat. Stops the boat slipping sideways when sailing. Can be raised or lowered using a rope.

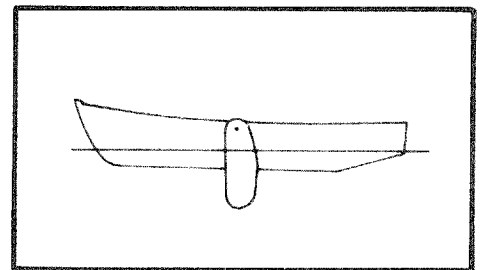

- Lift** The force produced by the wind blowing across a sail which drives the boat.

- Make Fast** To tie a rope to stop it moving or slipping.
- Mast** A pole or several poles on which sails and spars are hoisted.
- Mast Step** The block into which the bottom of the mast is fitted.

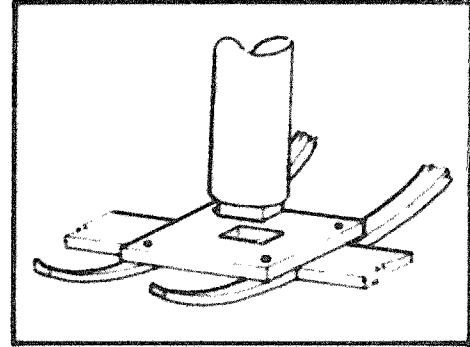

- Outrigger** A small float, like a canoe, which is attached alongside a bigger boat to improve its stability.
- Palm** Made of thick leather. Worn on the hand when hand-sewing sails. Protects the hand when pushing needles through sailcloth.

- Planking** Thick strips planks of wood, fixed edge to edge, which make up the hull of a boat.
- Purchase** Method used to make pulling ropes easier, explained on page 56).

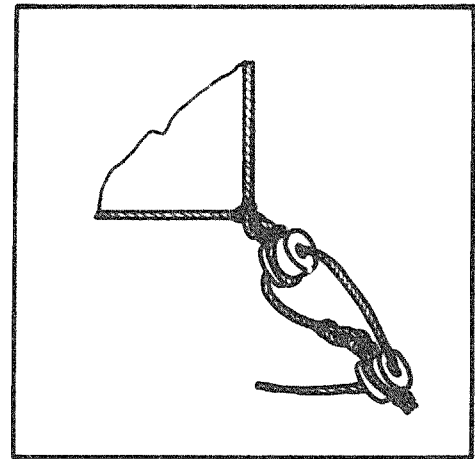

- Reef, Reefing** To make the sail smaller by folding or rolling, used when the wind is strong.

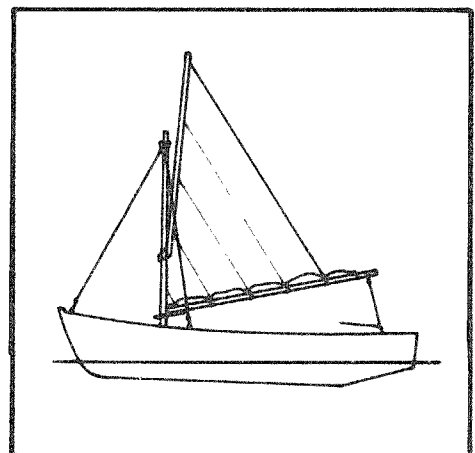

<b>Reef Points</b>	Points on the sail at which small ropes are used to tie up loose sail when reefing.
<b>Rig</b>	The spars, sails and rope needed to make a boat ready to sail.
<b>Rigging</b>	See Running Rigging and Standing Rigging.
<b>Rudder</b>	Moveable underwater part of the boat used for steering, instead of an oar.

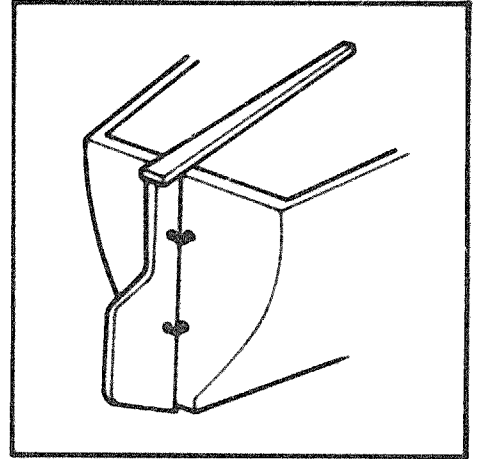

<b>Running Rigging</b>	Ropes to control the sails, such as halyards and sheets.
<b>Sea breeze</b>	Wind which blows from the sea towards the land when the sun is hot.

<b>Seize</b>	Method of tying the end of a rope back on itself to form a loop.
--------------	--

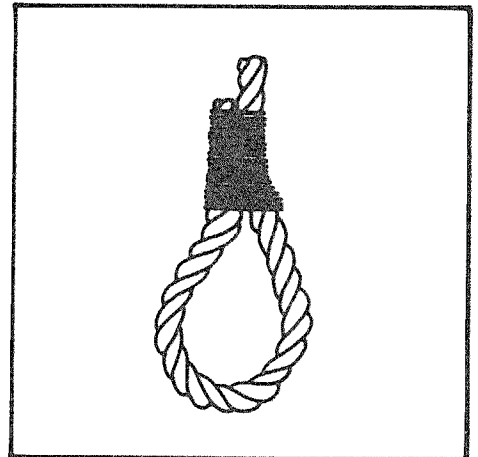

<b>Sheet</b>	Rope which is used to pull in or let out a sail.
--------------	--

<b>Shrouds</b>	Parts of the Standing Rigging which go to the sides of the boat.
----------------	--

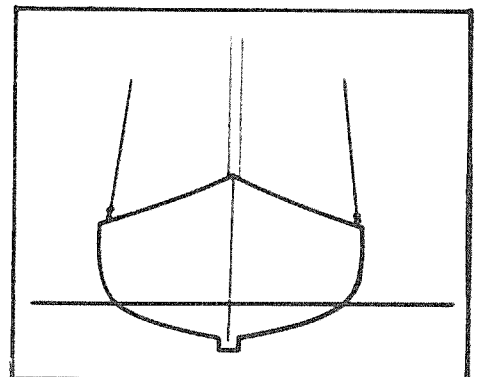

**Spar** A wooden or metal pole used to set the sails. Masts, booms, sprits and yards are all spars.

**Splice** Method of joining ropes together by interweaving the strands.

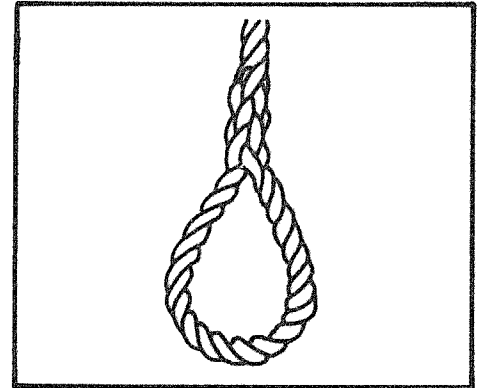

**Sprit** A spar used to support the top back corner of a sail (see Appendix 5).

**Stability** The stability of a boat is how hard it tries to stay upright when being tipped over by heavy fishing nets, people, waves, or the wind on the sails.

**Standing Rigging** Wires or ropes which hold the mast up. Usually three are used, one at each side, and one at the front of the boat.

**Stays** Parts of the Standing Rigging which go to the front or back of the boat.

**Step** See Mast Step.

**Stern** The back of the boat.

**Tacking** Turning the boat round whilst pointing towards the wind.

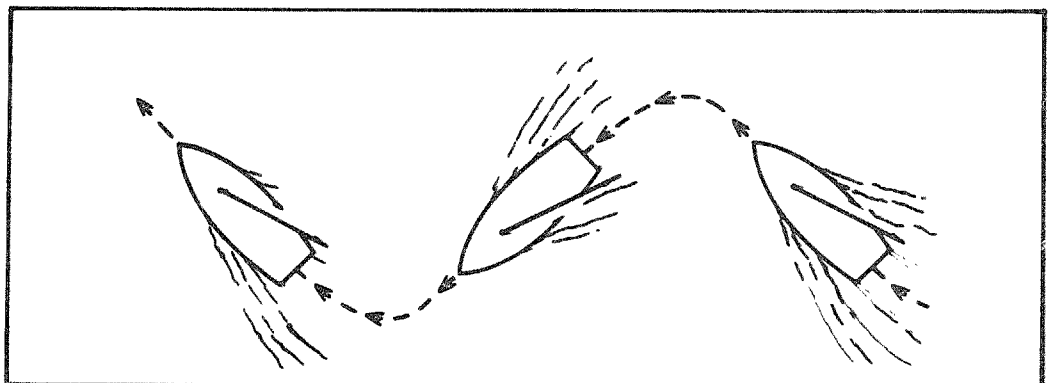

Thwart

A seat or bench fixed across the boat. A type of cross-member.

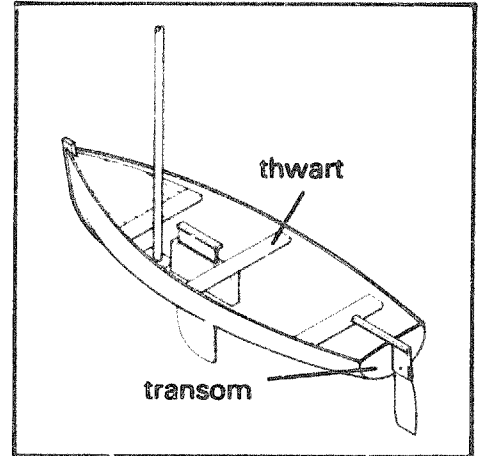

Transom

The flat back end of the boat, not used on all boats.

Waterline

The level of the water along the side of the boat when it is floating.

# **APPENDIX 2 – INTRODUCTION TO RIG DESCRIPTION APPENDICES**

**APPENDIX 2.**

Each of the following Appendices contains a short description of a particular rig, and tables of information to enable you to design and construct a rig.

The tables give the dimensions necessary to lay out a particular size of sail (see Sail-making Chapter 12). These measurements are exact.

Information on spar and rigging sizes is also given as a table. These measurements are approximate – they will help you find out the materials you need to buy for making the rig.

The following points should be noted:

- (A) The length of the mast is given to deck level and does not include the part of the mast inside the boat. Measure the depth of the boat and add this measurement to the mast length.

For example:

- Mast length (from table) = 4.5 metres
- Depth of boat = 0.7 metres
- Mast length needed =  $4.5 + 0.7$  metres = 5.2 metres

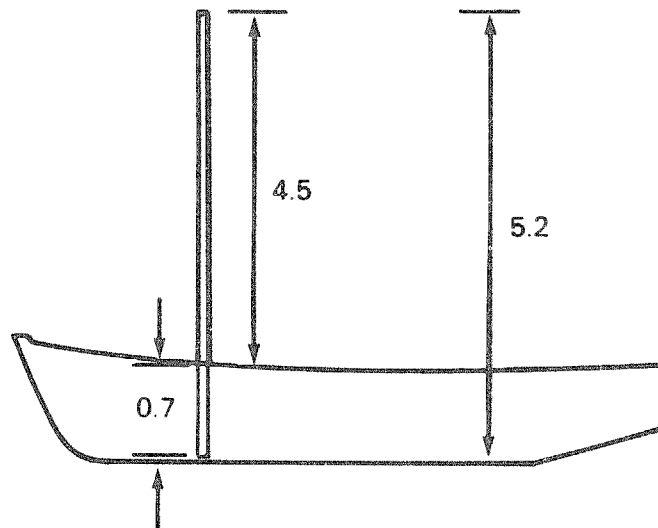

- (B) The thicknesses given for the mast and other spars are for good quality materials which are not cracked or rotten. If poor quality wood or other materials are used, these measurements will need to be made larger.
- (C) The lengths of the *shrouds* and forestay allow for attachment to mast and dead-eyes, although you should remember that the exact measurements depend on the length and width of the boat.
- (D) When making the rig, the sail, spars, rigging and ropes should be laid out on the ground to check that all the lengths are sufficient.

Example:

SAIL AREA	SAIL length of sides		
	A	B	C
5	4.7	2.3	3.6
10	6.5	3.5	5.4
square metres	metres	metres	metres

HALYARDS		SHEET		CONTROL LINE	
L	D	L	D	L	D
6.5	8	9	8	9	8
9	8	13	8	11	8
metres	milli-metres	metres	milli-metres	metres	milli-metres

So, if you need to make a 10 square metre sail, the tables above are used to find the length of the sail sides:

$$A = 6.5 \text{ metres}; \quad B = 3.5 \text{ metres}; \quad C = 5.4 \text{ metres.}$$

$$\text{Halyard length} = 9 \text{ metres} \quad \text{Halyard diameter} = 8 \text{ mm}$$

$$\text{Sheet length} = 13 \text{ metres} \quad \text{Sheet diameter} = 8 \text{ mm}$$

$$\text{Control line length} = 11 \text{ metres} \quad \text{Control line diameter} = 8 \text{ mm}$$



## APPENDIX 3 – LATEEN RIG

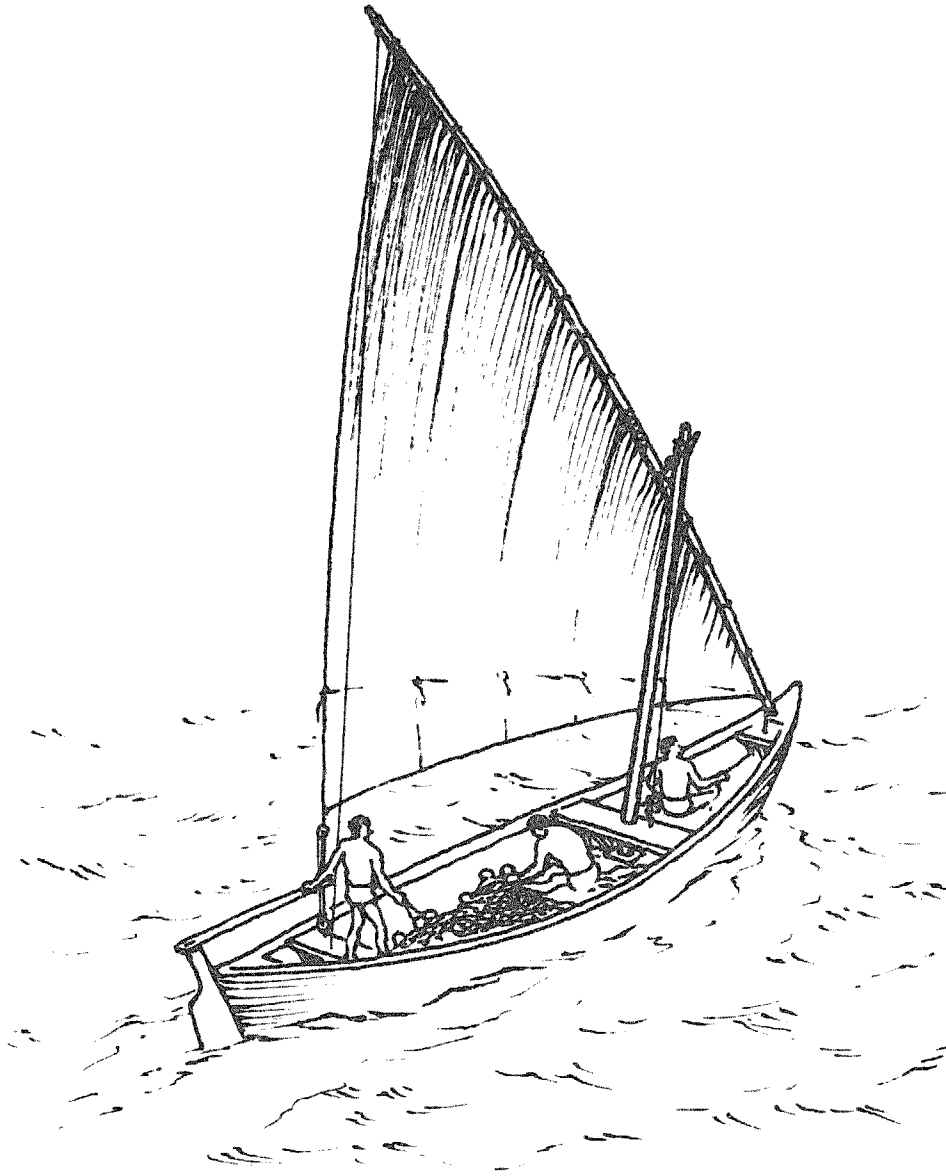

## LATEEN RIG

**General** The Lateen sail is three-sided, it sets on a short mast and has a long spar on the top edge of the sail. The Lateen rig has been used for centuries on traditional craft all over the world.

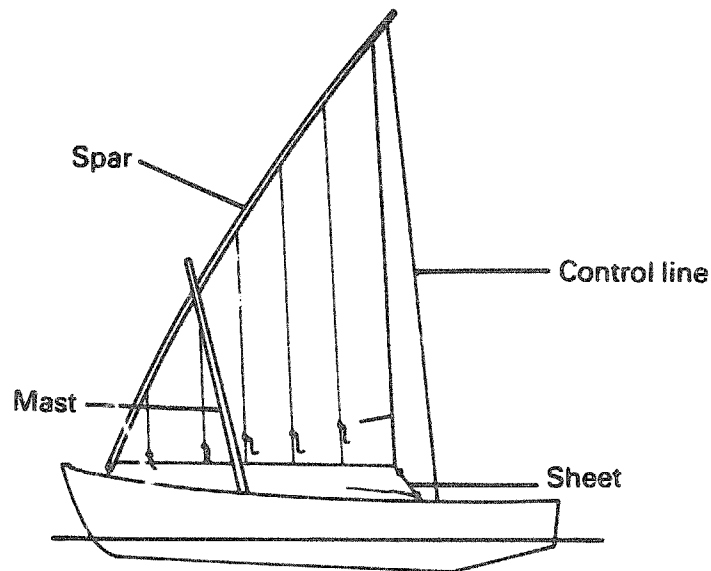

**Mast and Rigging** The mast should be angled forward slightly as shown in the drawing; this makes changing the sail from one side to the other easier. The mast is short and standing rigging is only needed on boats over 7 metres long. This rigging is changed from side to side each time the sail is tacked.

**Spar** The spar spreading the sail is very long and so needs to be strong and light. It can be made from several shorter pieces lashed together. The spar should be thicker in the middle than at either end.

**Sail** The top edge of the sail is laced to the spar using Method 1 (see page 69).

- Halyard** The sail is hoisted by a rope halyard tied to the upper spar. This halyard should be attached between one third and half way along the length of the spar from the bottom end. The end of the halyard is tied to a cleat on the cross-member which supports the mast.
- Sail Control** The angle of the sail is controlled by a rope (or sheet) at the back corner of the sail. Two further lines are used to control the sail. One, attached to the top of the spar, controls twist in the sail. The other, attached at the bottom of the spar, controls the angle of the spar.
- Handling** The sail is tacked by lowering and rehoisting on the new side. *Gybing* is achieved in the same way, but with practice the sail can be allowed to blow round in front of the mast. Sailing towards the wind or across the wind, the spar is angled upwards. When sailing downwind, the spar can be allowed to set horizontally.
- Reefing** The sail is reduced in strong winds by lowering the spar and tying off the loose sail along the bottom edge.
- Stowing** When not in use, the sail can either be stowed on deck or be pulled up against the spar so that it does not catch the wind.

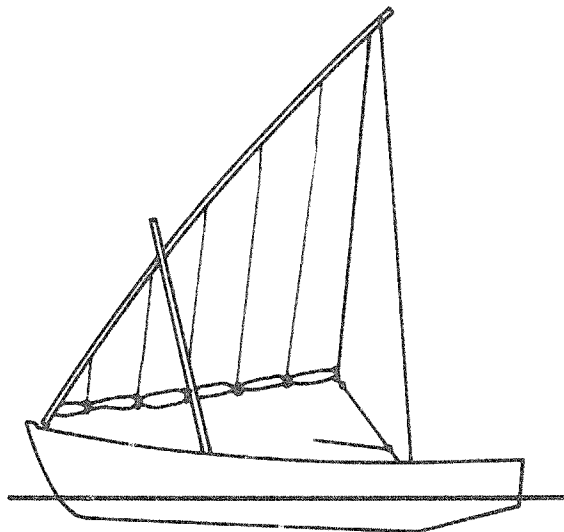

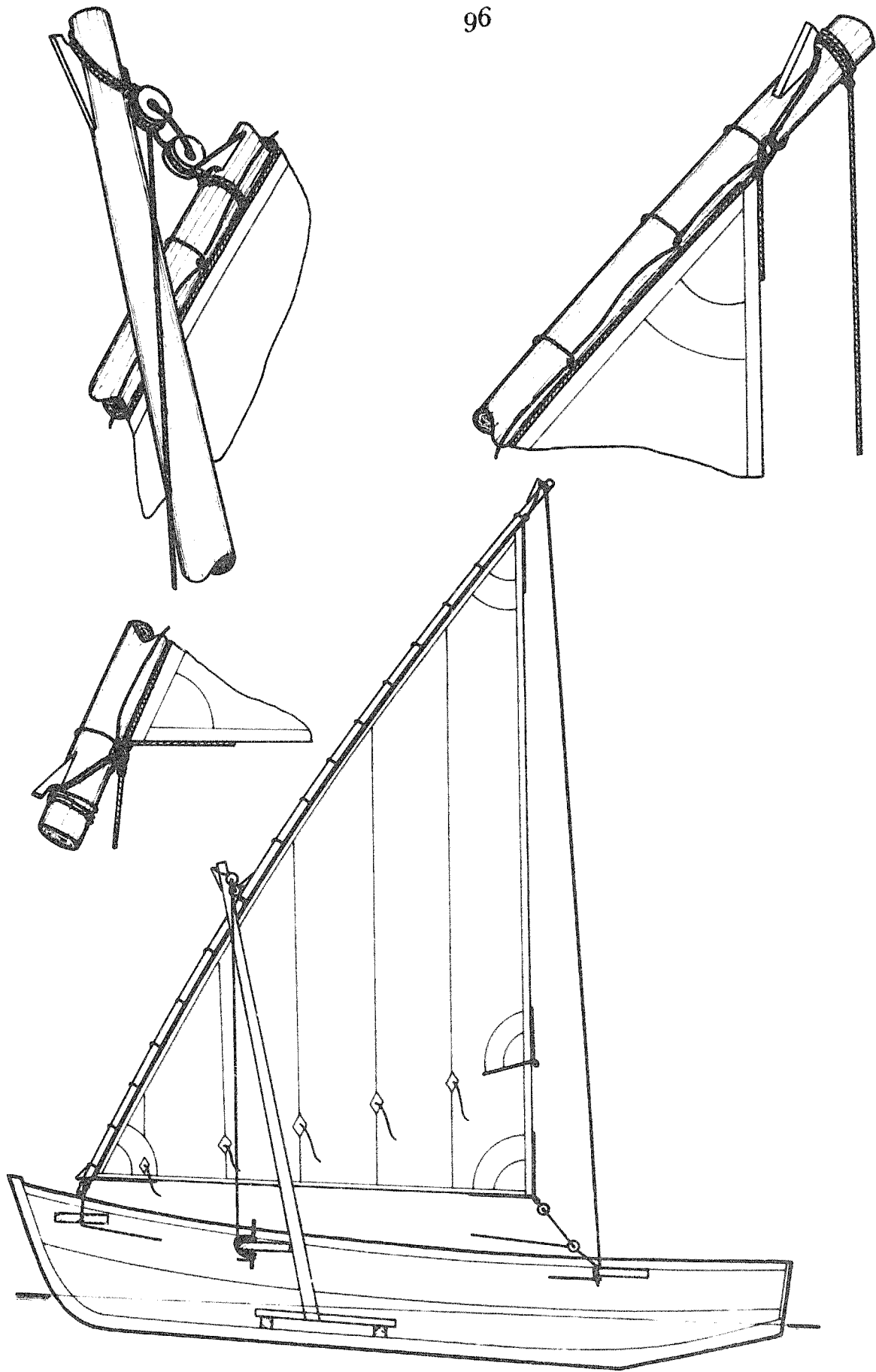

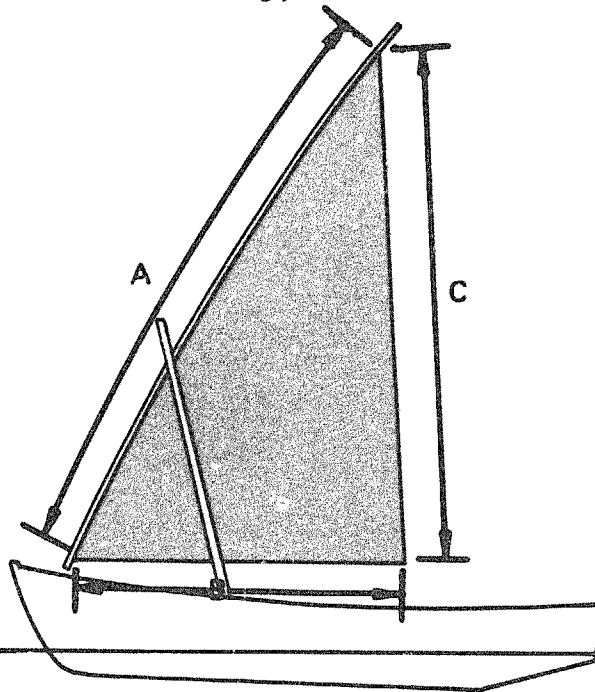

### SAILS AND RUNNING RIGGING

**ACCURATE DIMENSIONS**  
for laying out  
Sail Plans

SAIL AREA	SAIL lengths of sides		
	A	B	C
5	4.7	2.3	3.6
10	6.5	3.5	5.4
15	7.9	4.3	6.6
20	9.2	5	7.6
25	10.2	5.6	8.5
30	11.3	6.2	9.4
35	12.2	6.7	10.2
40	13	7.1	10.8
45	13.8	7.5	11.5
Square metres	metres	metres	metres

**APPROXIMATE DIMENSIONS**  
for estimating materials needed

HALYARD		SHEET		CONTROL LINE	
L	D	L	D	L	D
6.5	8	9	8	9	8
9	8	13	8	11	8
11	8	15	8	12	8
12	10	18	10	14	10
13	10	20	10	15	10
14	10	22	10	16	10
15	12	23	12	17	12
16	12	25	12	18	12
18	12	26	12	20	12
metres	milli-metres	metres	milli-metres	metres	milli-metres

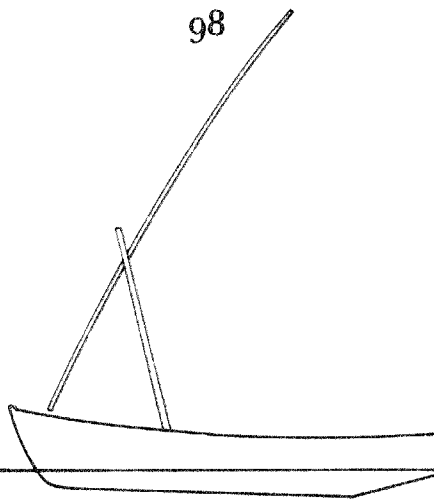

## SPARS AND STANDING RIGGING

**Note 1:** Measure the depth inside the hull and add this to the measurements in the table below. This gives the total mast length.

### APPROXIMATE DIMENSIONS for estimating materials needed

SAIL AREA	MAST		SPAR	
	L	D	L	D
5	2.5	50 - 80	5.2	70 - 90
10	3.3	50 - 80	7.2	80 - 100
15	3.9	70 - 100	8.7	90 - 110
20	4.5	80 - 110	10.1	100 - 120
25	5.1	80 - 110	11.2	100 - 120
30	5.3	80 - 110	12	120 - 140
35	5.5	90 - 120	13	120 - 140
40	5.8	90 - 120	14	130 - 150
45	6.1	100 - 130	14.8	130 - 150
square metres	metres	millimetres	metres	millimetres

**Note 2:** The greater the area the larger the diameter of the spar.

## APPENDIX 4 - CRAB CLAW RIG

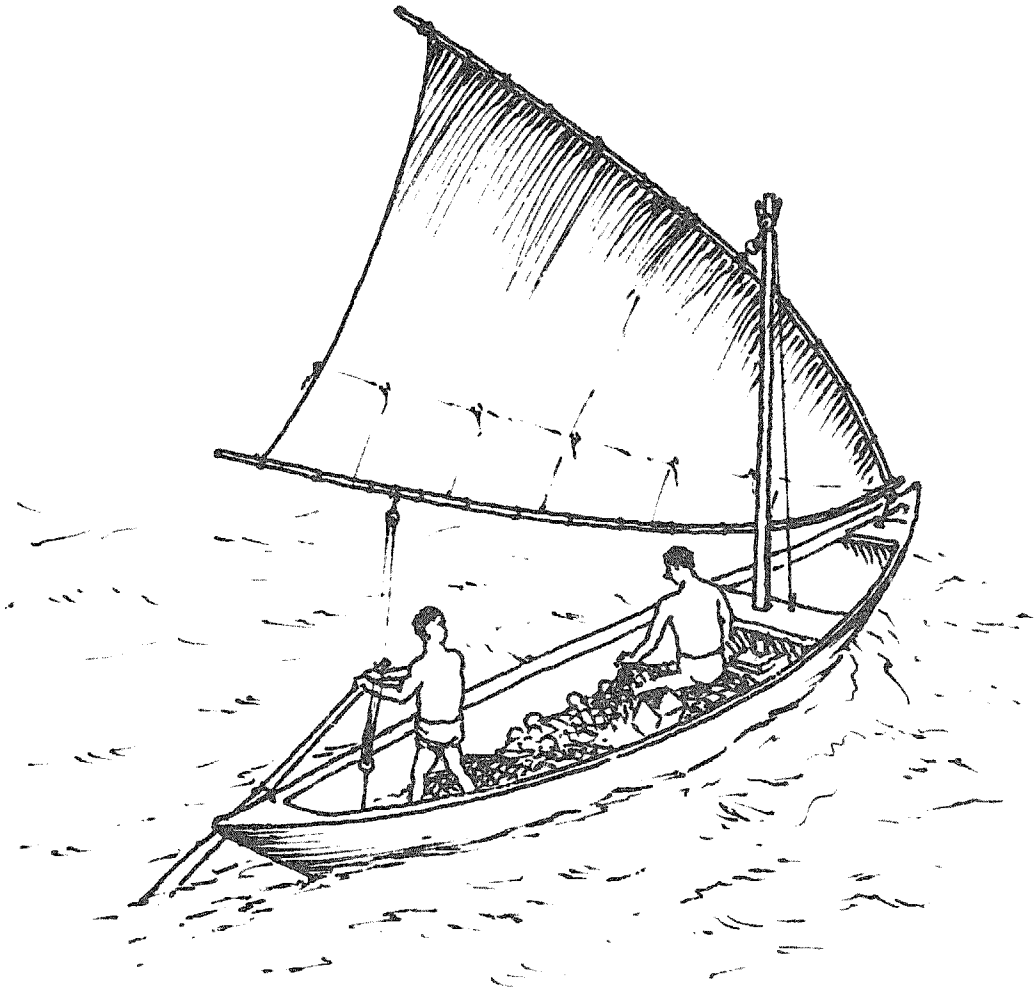

## CRAB CLAW RIG

**General** The Crab Claw sail is three-sided with long spars on the upper and lower edges. It is set on a short mast. This rig is common on multihull craft in the Pacific.

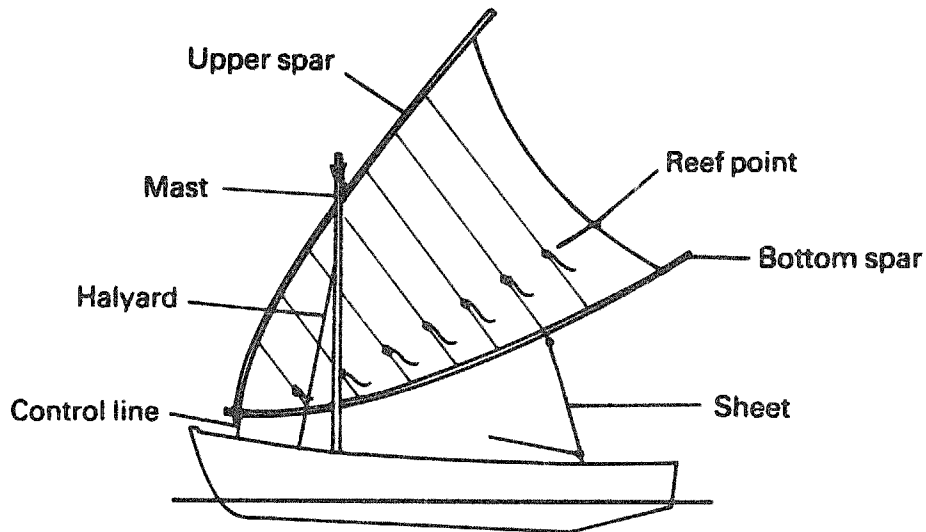

**Mast and Rigging** The mast is installed in an upright position. Since the mast is short, standing rigging is not usually used to support it.

**Spars** The spars spreading the sail are long, so they need to be strong and light. They may be made from short lengths lashed together, or from a long piece of wood. An ideal material is Bamboo. The spars are better if they are curved to follow the shape of the sail.

**Sail** The top and bottom edges of the sail are laced to the spars using Method I (see page 69).

**Halyard** The sail is hoisted by a rope halyard tied to the upper spar. This halyard is tied about halfway along the upper spar. When hoisted, the halyard is tied to a cleat on the cross-member which supports the mast.



**Sail Control** The angle of the sail is controlled by a rope (or sheet) tied to the bottom spar. A further line attached at the front lower corner of the sail is used to control the amount the sail is tilted up or down.

**Handling** When tacking, the sail is pulled round the back of the mast and the forward line re-attached. Gybing is done in the same way. The angle at which the sail is tilted up or down is important. A good all-round position is shown in the drawing, but when sailing downwind, the sail can be more horizontal.

**Reefing** The sail is reduced in strong winds by lowering the upper spar and tying off the loose sail.

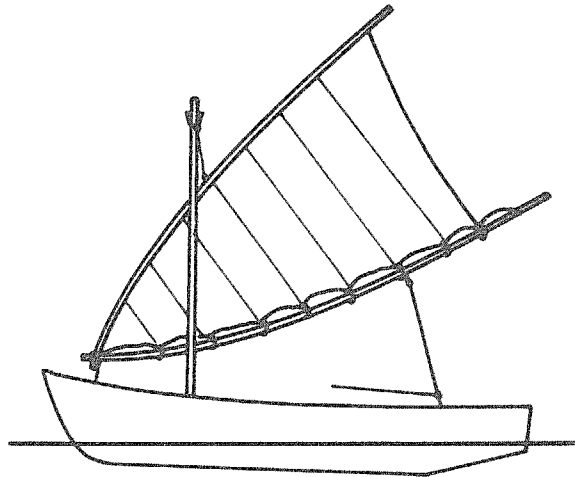

**Stowing** When not in use, the sail can either be stowed on deck or be pulled up against the mast so that it does not catch the wind.

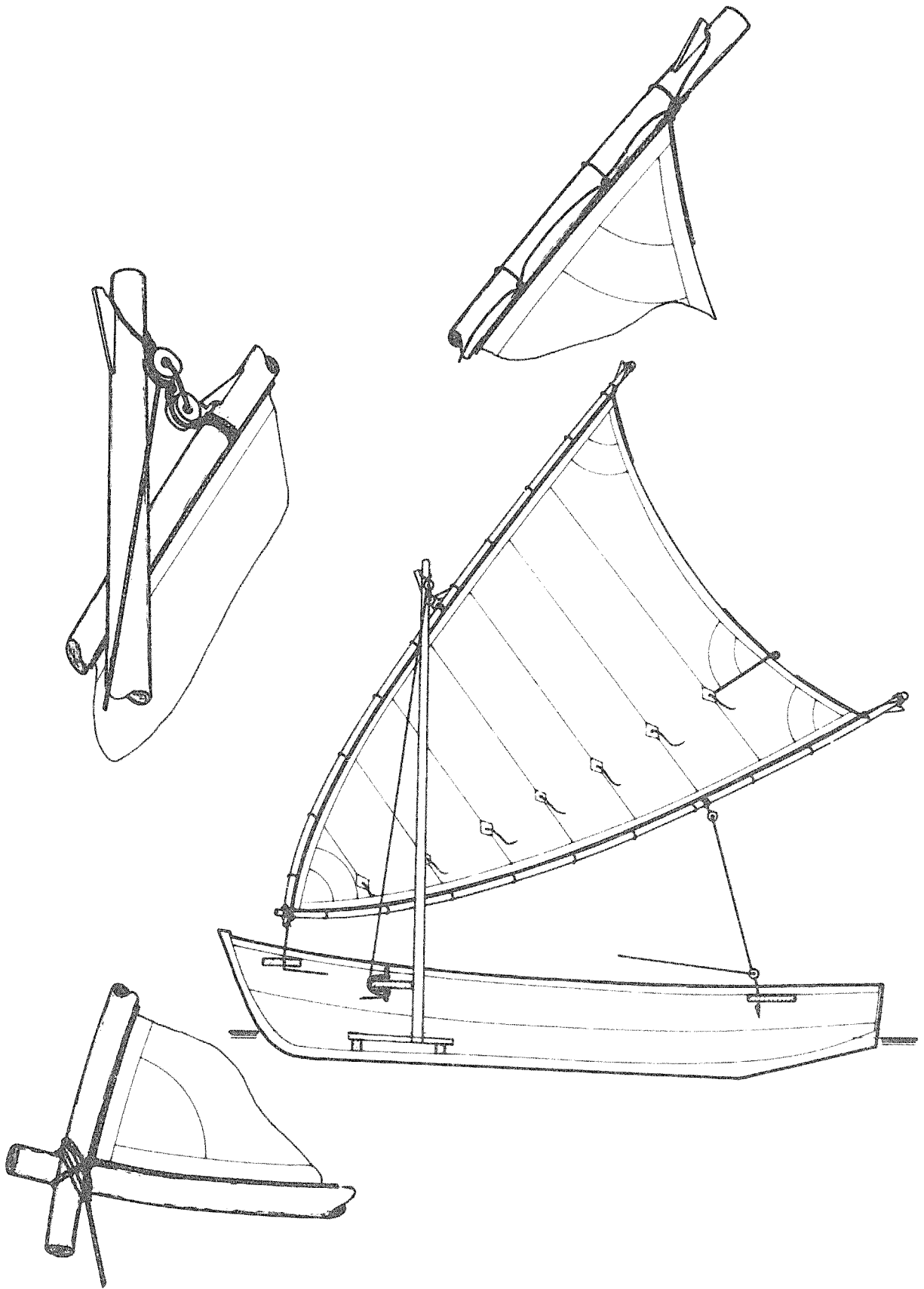

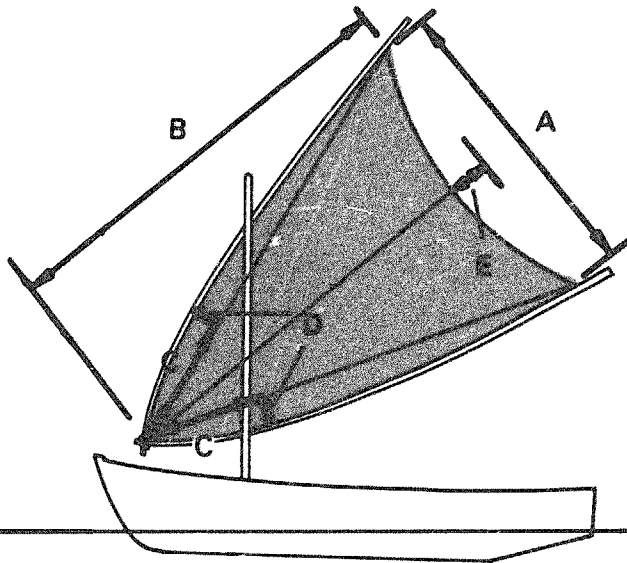

**SAILS AND RUNNING RIGGING**

**ACCURATE DIMENSIONS  
for laying out Sail Plans**

SAIL AREA	SAIL lengths of sides				
	A	B	C	D	E
5	2.5	3.5	1.2	200	270
10	3.5	4.9	1.7	280	380
15	4.3	6.1	2.1	340	470
20	5	7	2.5	400	550
25	5.6	7.8	2.8	440	610
30	6.1	8.6	3	480	670
35	6.6	9.3	3.3	520	720
40	7.1	9.9	3.5	560	770
45	7.5	10.5	3.7	600	820
squads metres	metres	metres	metres	milli- metres	milli- metres

**APPROXIMATE DIMENSIONS  
for estimating materials**

HALYARD		SHEET	
L	D	L	D
8	8	9	8
11	8	11	8
13	8	13	8
15.5	10	15	10
17	10	17	10
19	10	18	10
20	12	19	12
22	12	20	12
24	12	22	12
metres	milli- metres	metres	milli- metres

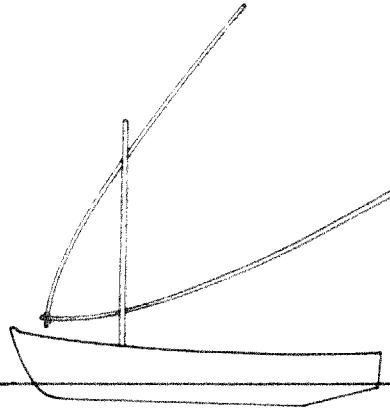

### SPARS AND STANDING RIGGING

**Note 1:** Measure the depth inside the boat and add this to the mast length in the table below. This gives the total mast length.

APPROXIMATE DIMENSIONS for estimating materials needed				
SAIL AREA	MAST		UPPER SPAR & LOWER SPAR	
	L	D	L	D
5	2.8	50 - 80	4.1	50 - 70
10	4	70 - 100	5.8	50 - 70
15	4.9	90 - 120	7.1	60 - 80
20	5.7	100 - 130	8.1	60 - 80
25	6.3	100 - 130	9.1	60 - 80
30	6.9	100 - 130	10	80 - 100
35	7.5	110 - 140	10.8	80 - 100
40	8	120 - 150	11.5	80 - 100
45	8.5	120 - 150	12.2	100 - 120
Square metres	metres	milli metres	metres	milli metres

**Note 2:** Before cutting spars and rigging to length, lay out the complete rig on the ground to check that lengths are adequate.

## APPENDIX 5 – SPRIT RIG

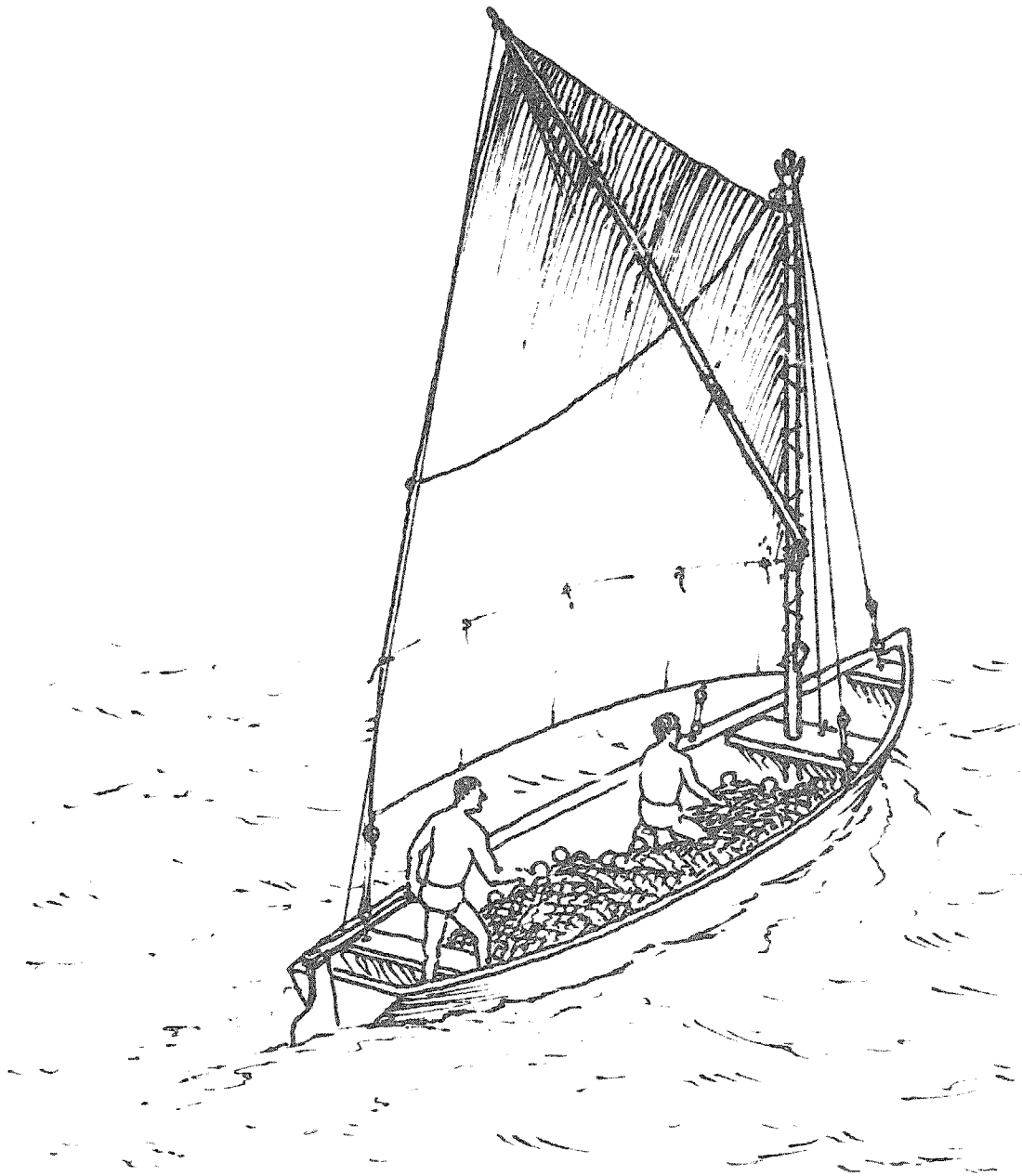

## SPRIT RIG

### General

The Sprit rig uses a four-sided sail which is spread by a long spar across the sail, called a sprit. This rig is most commonly used on small boats, and sometimes on larger boats with a jib (see Appendix 8). This rig is easily handled by a small crew.

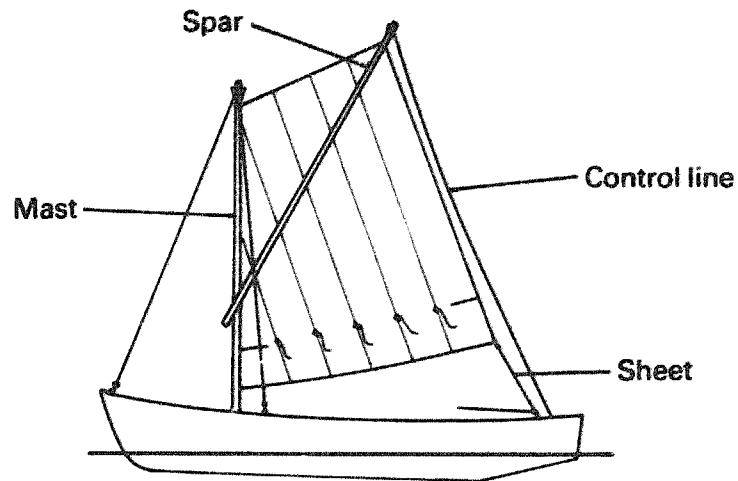

### Mast and Rigging

The mast should be in an upright position with the standing rigging tight.

### Spar

The spar (or *sprit*) is long, so it needs to be strongly made. It is best made from a single piece of wood, but several pieces can be used if they are strongly lashed together (see page 51). The spar should not bend; the sail will work much better if the sprit is very stiff.

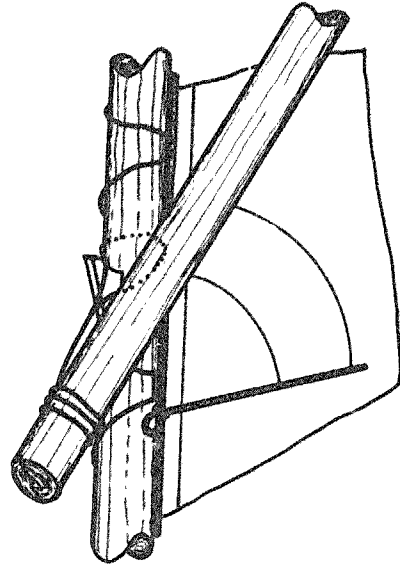

The bottom end of the spar is tied to the mast using a rope which is passed loosely round the mast and back to the spar. This rope fits over a chock on the mast, and supports the spar.

A boom is sometimes used when sailing away from the wind.

**Sail** The front edge of the sail is laced to the mast using Method 2 (see page 70). The lacing should not be pulled too tight. The top corner of the sail should be tied to the spar with a knot which will not slip down the spar.

**Halyard** A single halyard hoists the sail, and the end is tied to a cleat on the cross-member which supports the mast.

**Sail Control** The angle of the sail is controlled by a rope (or sheet) at the lower rear corner of the sail. The upper end of the spar (or sprit) is also controlled by a rope tied to the top of the spar. This sprit control system reduces the twist in the sail when sailing across or towards the wind.

**Handling** The sail turns behind the mast when tacking or gybing, so does not need any special techniques.

**Reefing**

The sail can be reduced in strong winds by two methods:

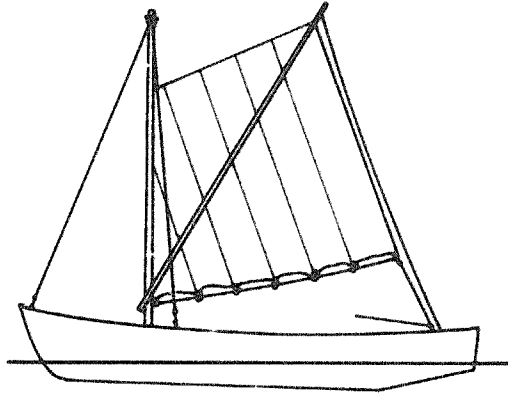

**ONE** By lowering the sail down the mast, and tying the excess at the bottom edge.

The spar is lowered down the mast, so there should be a second chock on the mast at the level of the boom to support it.

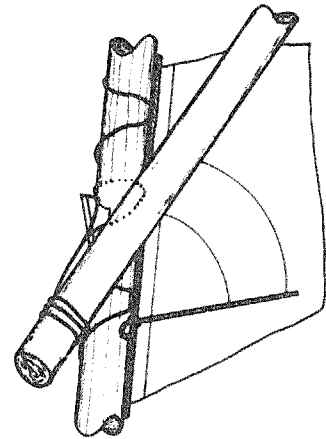

**TWO** By removing the sprit to leave a triangle. The excess sail should be tied back.

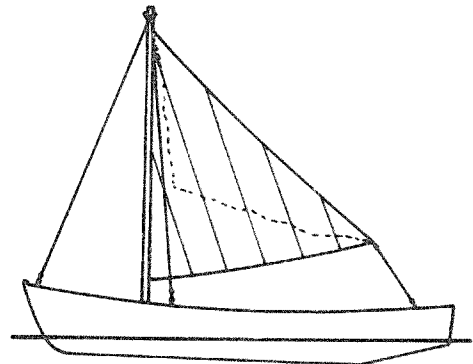



**Stowing**

The sprit rig has a useful method of stowing the sail at the top of the mast. A rope is taken from the top of the mast, around the sail, and back to the top of the mast. When this rope is pulled tight, the middle of the sail is pulled towards the top of the mast, leaving the deck clear for fishing gear handling. This is known as *brailing*.

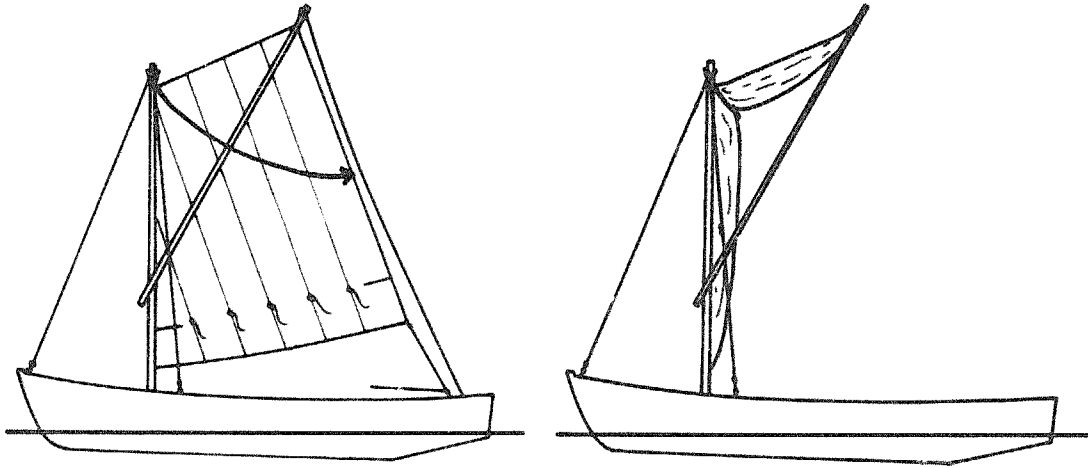

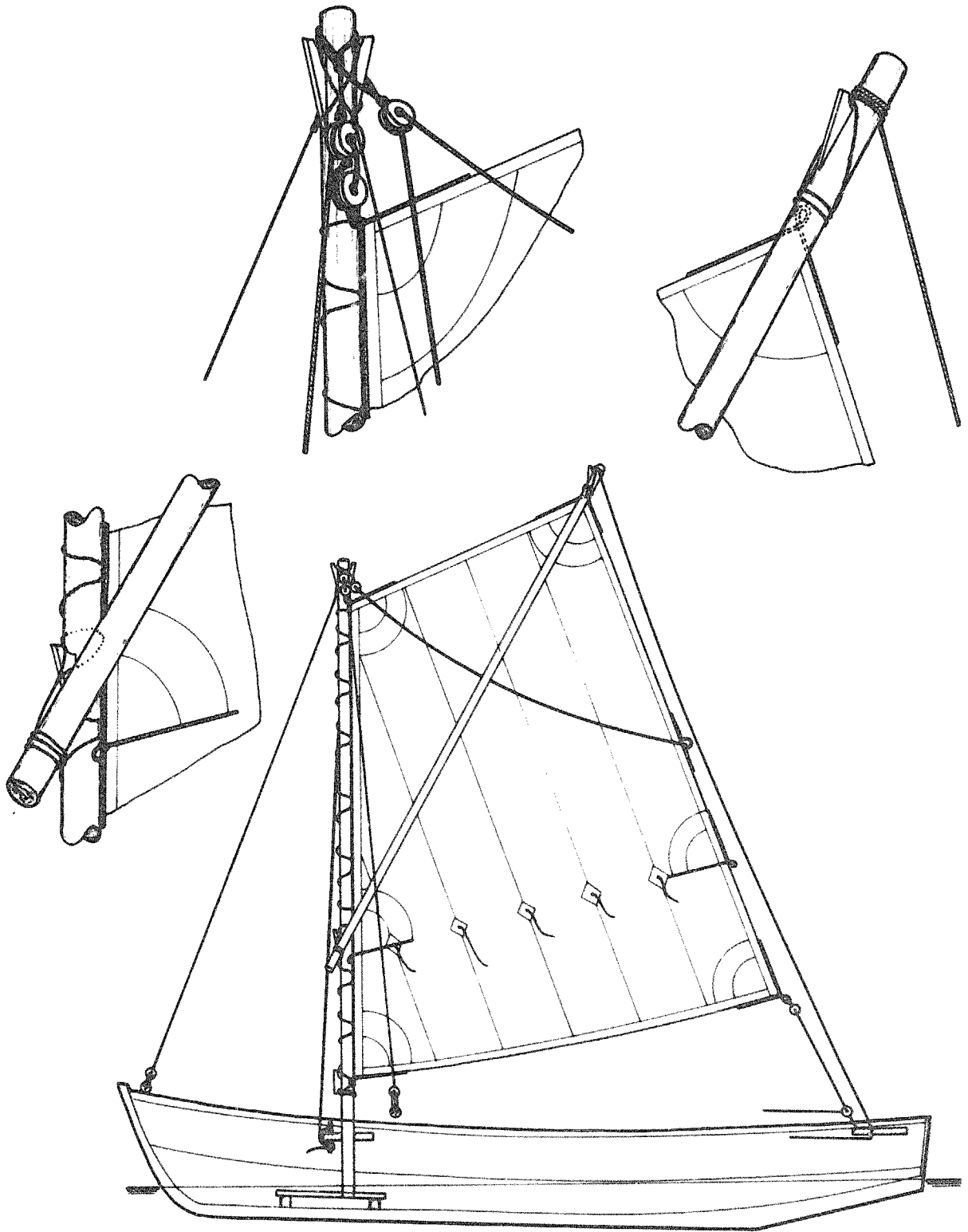

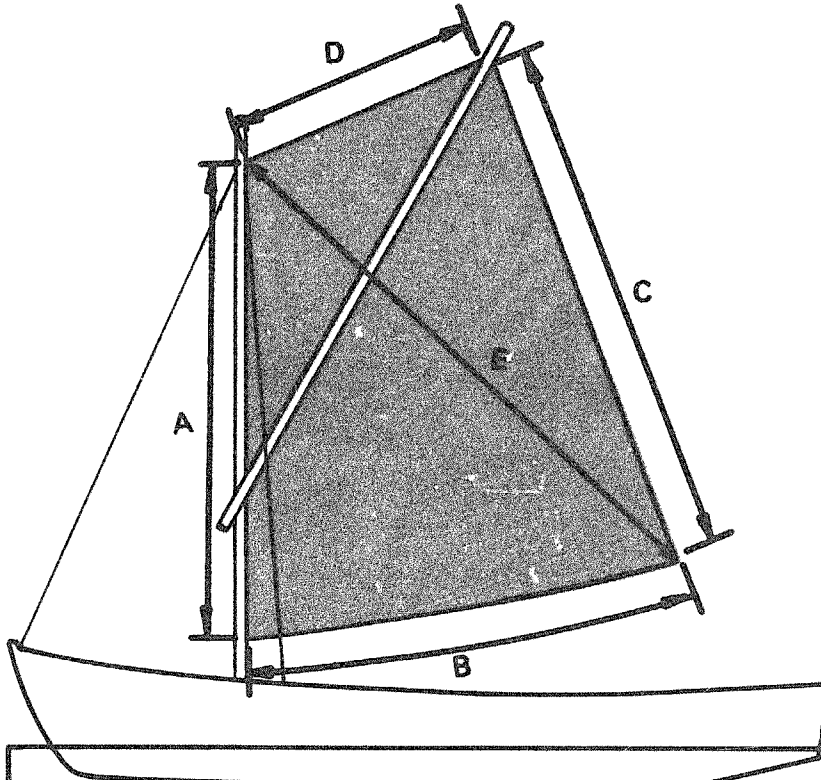

### SAILS AND RUNNING RIGGING

#### ACCURATE DIMENSIONS for laying out Sail Plans

SAIL AREA	SAIL lengths of sides				
	A	B	C	D	E
5	2.5	2.3	2.85	1.4	3.2
10	3.6	3.3	4	2	4.5
15	4.4	4	4.9	2.5	5.5
20	5.1	4.6	5.7	2.8	6.4
25	5.7	5.2	6.4	3.2	7.2
30	6.2	5.65	7	3.5	7.8
35	6.7	6.1	7.5	3.8	8.4
40	7.15	6.5	8	4	9
45	7.6	6.9	8.5	4.3	9.6
Square metres	metres	metres	metres	metres	metres

#### APPROXIMATE DIMENSIONS for estimating materials needed

HALYARD		SHEET		CONTROL LINE	
L	D	L	D	L	D
8	8	10	8	6	8
10	8	14	8	8	8
12	8	17	8	10	8
13.5	10	19	10	11	10
14.5	10	22	10	13	10
15.5	10	24	10	14	10
16.5	12	25	12	15	12
17.5	12	27	12	1	12
18.5	12	30	12	17	12
metres	milli-metres	metres	milli-metres	metres	milli-metres

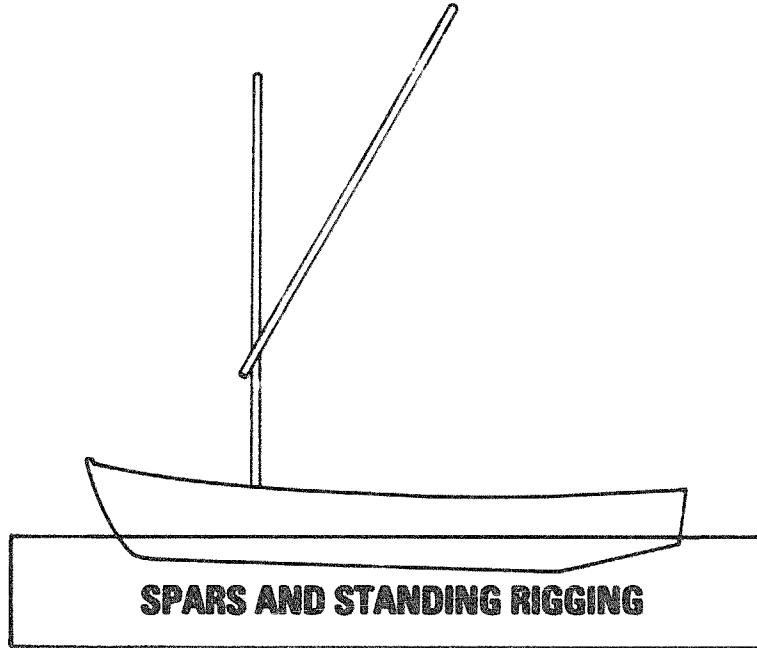

**Note 1:** Measure the depth inside the lower mast and add this to the mast length in the table below. This gives the total mast length.

**APPROXIMATE DIMENSIONS**  
for estimating materials needed

SAIL AREA	MAST		BOOM		SPRIT		FORESTAY		SHROUDS	
	L	D	L	D	L	D	L	D (wire)	L	D (wire)
5	3.8	50-80	2.5	30-50	3	40-60	4.1	3	3.9	3
10	5	70-100	3.6	40-60	4.2	40-60	5.5	3	5.1	3
15	5.7	70-100	4.4	40-60	5	50-70	6.2	4	5.9	4
20	6.4	90-120	5.1	40-60	5.7	60-80	7	4	6.6	4
25	7	90-120	5.7	50-70	6.4	60-80	7.7	4	7.2	4
30	7.7	100-130	6.2	50-70	7	70-90	8.5	5	7.9	5
35	8.2	100-130	6.7	60-80	7.5	70-90	9	5	8.5	5
40	8.7	120-150	7.2	70-90	8	80-100	9.5	5	9	5
45	9.1	120-150	7.6	80-100	8.5	80-100	10	5	9.5	5
Square metres	metres	millimetres	metres	millimetres	metres	millimetres	metres	milli-metres	metres	milli-metres

**Note 2:** Before setting up the rigging, check the mast and boom are square to the ground to check that they are straight.

## APPENDIX 6 – GUNTER RIG

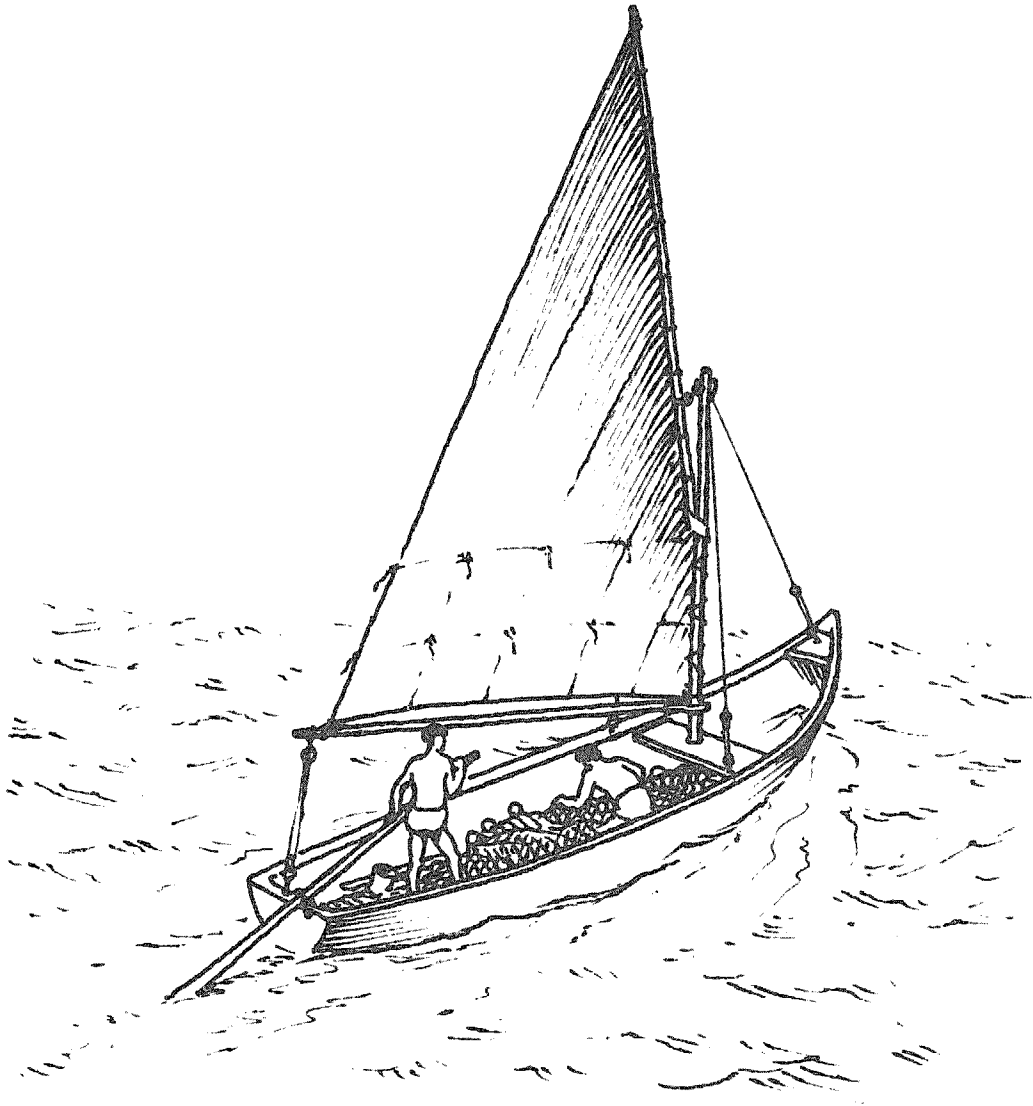

## GUNTER RIG

### General

The Gunter sail is four-sided. The top spar is almost upright, which allows a tall sail to be set on a short mast. The bottom edge of the sail is spread by a boom. The Gunter rig is most commonly used on small boats and is especially good when sailing towards the wind. A jib (see Appendix 8) may be easily fitted. This rig is easily handled by a small crew.

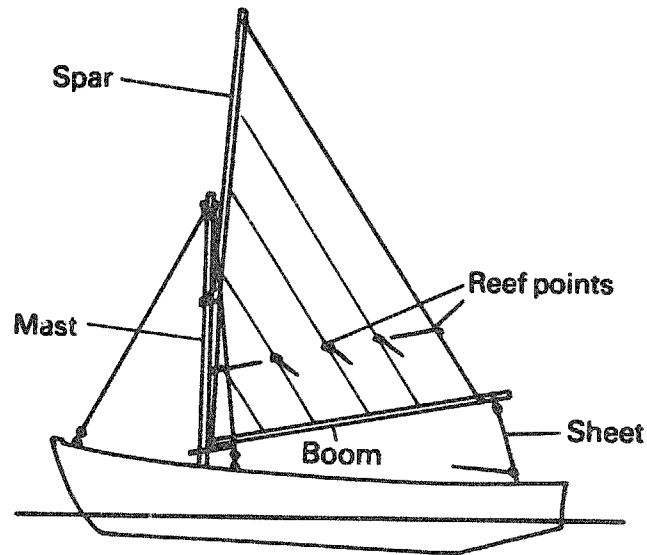

### Mast and Rigging

Standing rigging is used to support the mast. The mast should be upright, with the rigging tight.

### Spar

The spar is long, so it needs to be strongly made. It is best made from a single piece of wood, but several pieces can be used, if they are strongly lashed together (see page 51).

The bottom end of the spar is positioned on the mast by a pair of *jaws*, and held against the mast by a short rope. The jaws are made from two chocks. They need both to be strongly made and strongly held to the end of the spar.

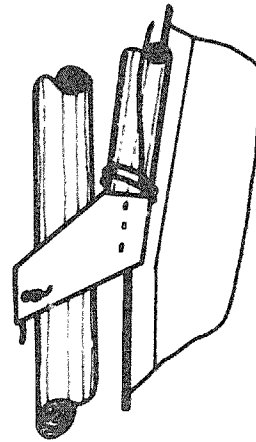

The front end of the boom also has jaws to position it against the mast. These are also held against the mast to stop boom movement. They are made either from the fork of a tree, or from two chocks, as shown in the drawing.

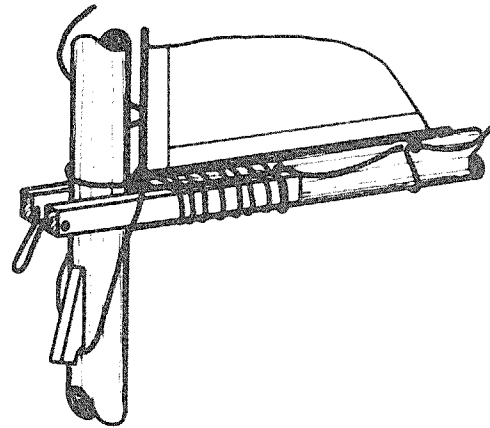
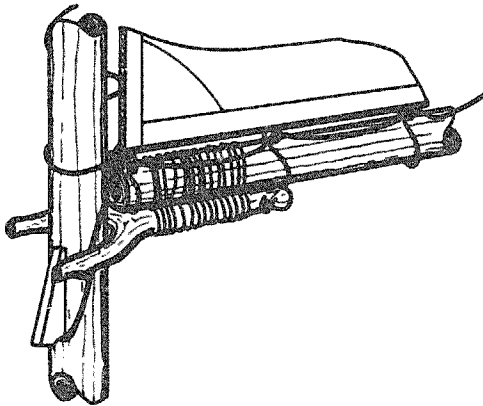

### Sail

The top edge of the sail is laced to the spar using Method 1 (see page 69). The bottom edge of the sail can either be laced to the boom using Method 1, or it can be pulled tight at the back corner and tied, leaving the bottom of the sail unlaced. The front edge of the sail is laced to the mast using Method 2 (see page 70), taking care not to pull the lacing too tight.

**Halyard** The sail is hoisted by a single rope halyard. This should be tied to the spar about one-third of the spar length from the bottom end. When hoisted, the halyard is tied to a cleat on the cross-member which supports the mast.

**Sail Control** The angle of the sail is controlled by a rope (or sheet) on the back end of the boom.

**Handling** The sail is easy to handle. It turns behind the mast when tacking or gybing, so does not need any special techniques.

**Reefing** The sail can be reduced in strong winds by lowering the spar and tying the loose sail at the bottom edge. The halyard should then be moved further up the spar to keep the spar upright.

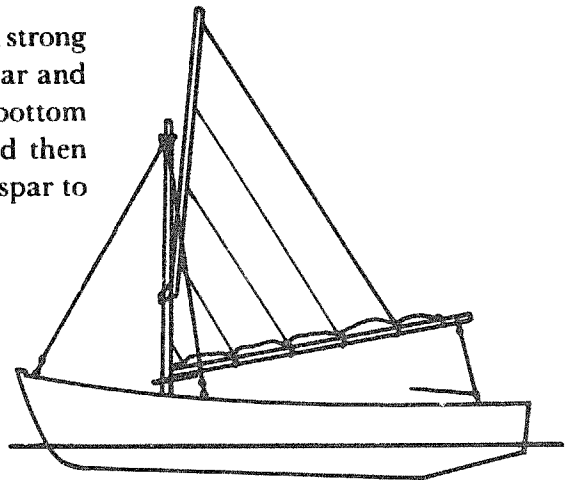

**Stowing** When not in use, the sail is either stowed on deck or the boom can be tied against the mast to keep the deck clear for fishing gear handling.



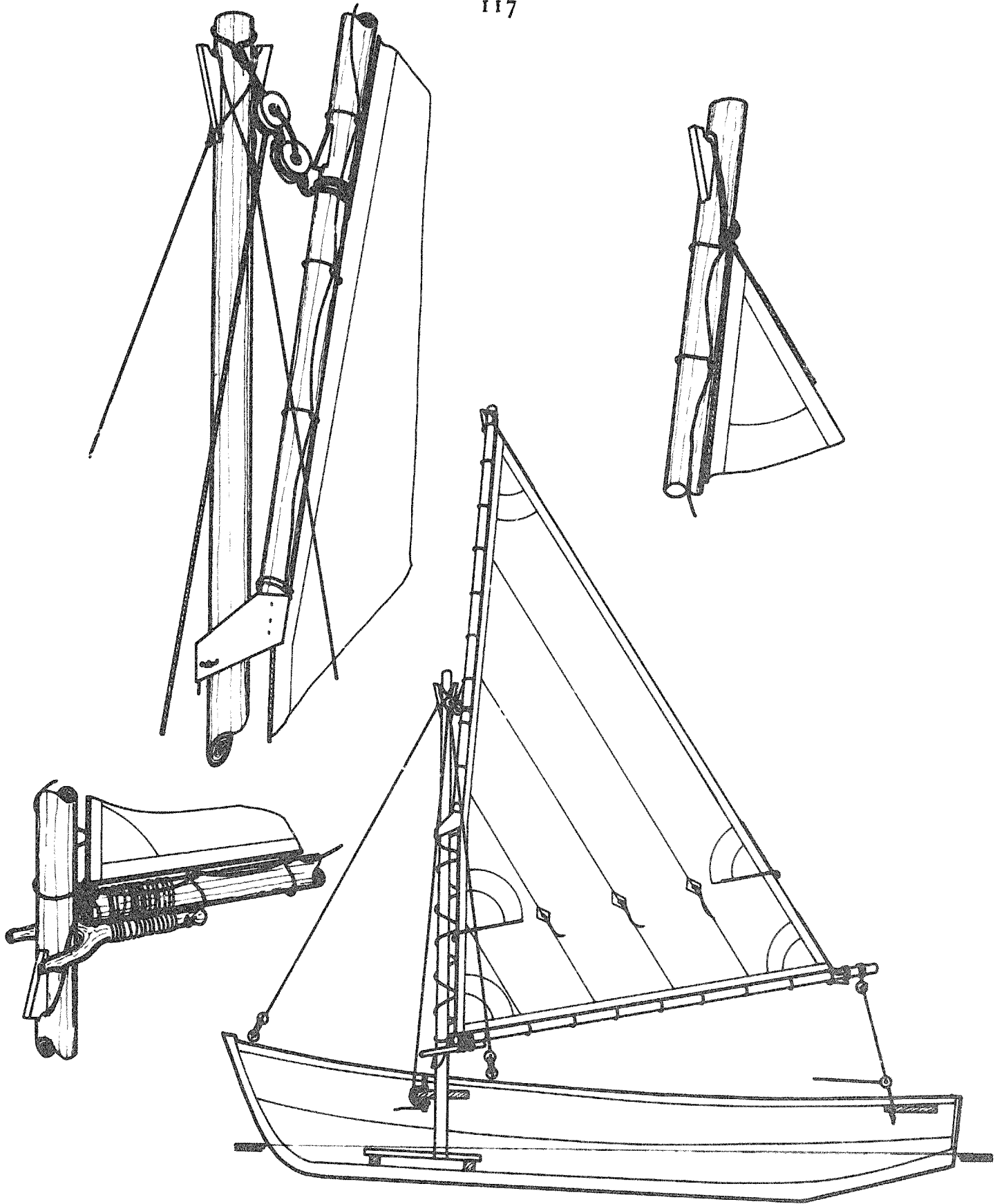

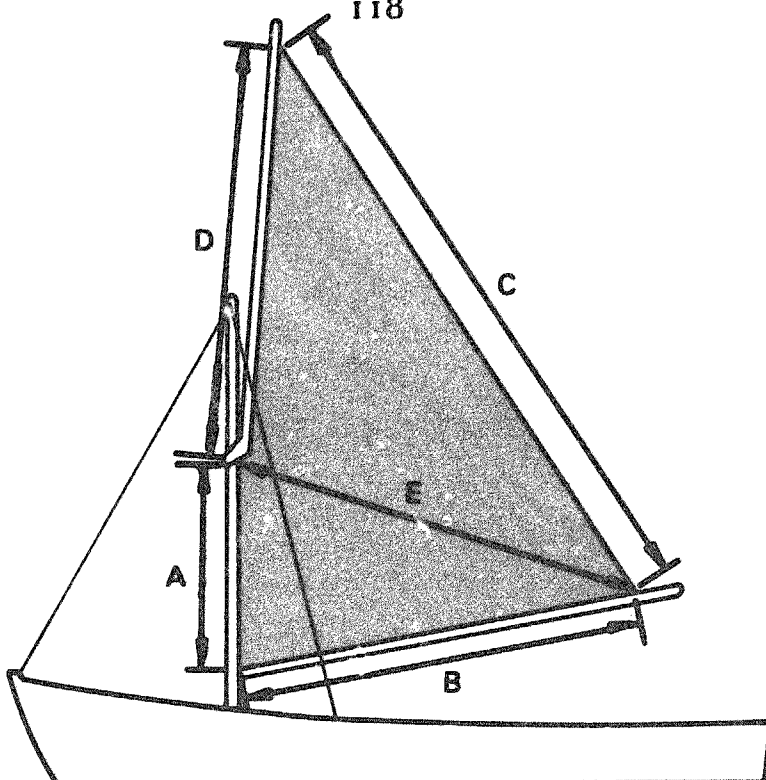

### SAILS AND RUNNING RIGGING

#### ACCURATE DIMENSIONS for laying out Sail Plans

SAIL AREA.	SAIL Lengths of sides				
	A	B	C	D	E
5	1.35	2.5	4.2	2.6	2.7
10	1.9	3.5	5.9	3.7	3.9
15	2.35	4.3	7.2	4.5	4.8
20	2.7	5	8.4	5.2	5.5
25	3	5.6	9.3	5.8	6.1
30	3.3	6.1	10.3	6.3	6.7
35	3.6	6.6	11.1	6.9	7.3
40	3.8	7.1	11.8	7.3	7.7
45	4	7.5	12.6	7.8	8.1
Square metres	metres	metres	metres	metres	metres

#### APPROXIMATE DIMENSIONS for estimating materials

HALYARD		SHEET	
L	D	L	D
6	8	9	8
8	8	12	8
10	8	15	8
11	10	17	10
12	10	19	10
13	10	21	10
15	12	23	12
16	12	24	12
17	12	25	12
metres	milli-metres	metres	milli-metres

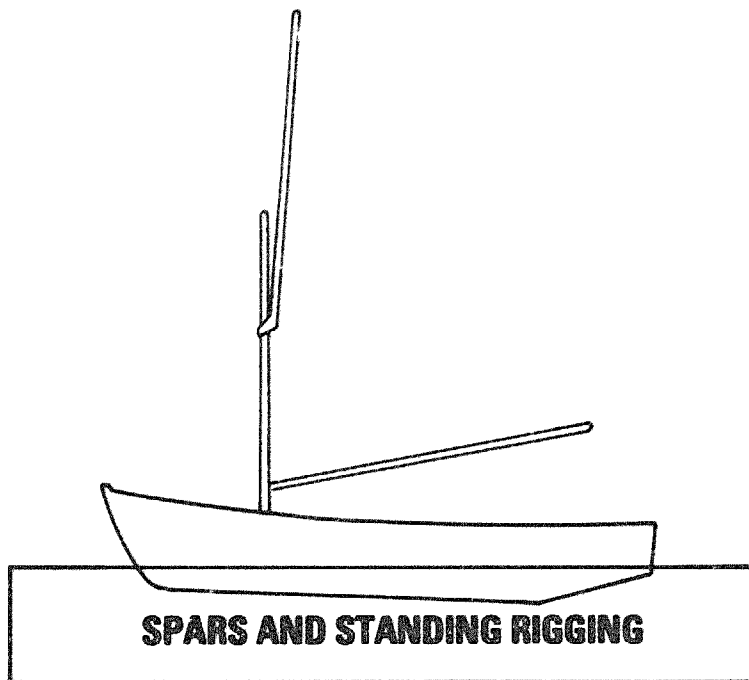

**Note 1:** Measure the depth inside the boat and add this to the mast length in the table below. This gives the total mast length.

<b>APPROXIMATE DIMENSIONS for estimating materials needed</b>										
SAIL AREA	MAST		BOOM		SPAR		FORESTAY		SHROUDS	
	L	D	L	D	L	D	L	D (wire)	L	D (wire)
5	3.3	50 - 80	2.8	30 - 50	2.9	30 - 50	3.3	3	3.1	3
10	4.4	50 - 80	3.9	40 - 60	4.1	40 - 60	4.4	3	4.1	3
15	5.1	70 - 100	4.9	40 - 60	5	50 - 70	5	3	4.7	3
20	5.9	70 - 100	5.5	50 - 70	5.7	50 - 70	5.7	4	5.4	4
25	6.6	70 - 120	6.2	60 - 80	6.4	50 - 70	6.2	4	5.9	4
30	7.2	90 - 120	6.8	60 - 80	7	60 - 80	6.8	4	6.4	4
35	7.9	100 - 130	7.3	70 - 90	7.6	60 - 80	7.4	5	7	5
40	8.3	100 - 130	7.9	70 - 90	8	70 - 90	7.9	5	7.4	5
45	8.8	110 - 140	8.3	80 - 100	8.7	80 - 100	8.2	5	7.8	5
Square metres	metres	millimetres	metres	millimetres	metres	millimetres	metres	milli- metres	metres	milli- metres

**Note 2:** Before cutting spars and rigging to length, lay out the complete rig on the ground to check that lengths are adequate.

## APPENDIX 7 - DIPPING LUG RIG

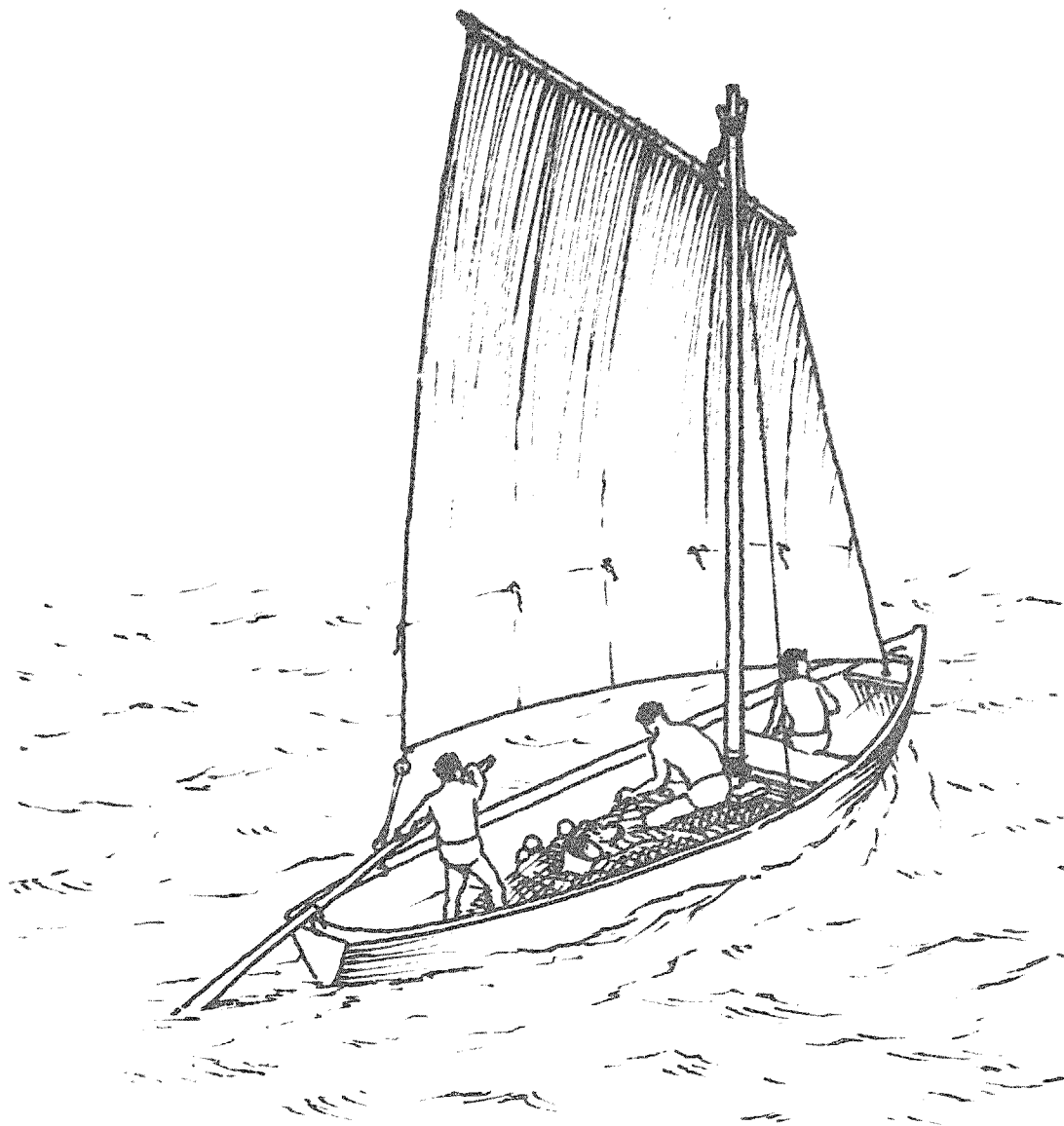

## DIPPING LUG RIG

### General

The Dipping Lug has a four-sided sail which is spread by a spar at the upper edge. It can be used on boats of all sizes. It is not supported by standing rigging, so on small boats the mast may easily be removed or lowered to the deck. This makes the Dipping Lug rig particularly suitable for fishing boats which operate through surf on to a beach. The Dipping Lug rig sails well towards the wind. It also performs well across the wind, but needs a boom when sailing downwind.

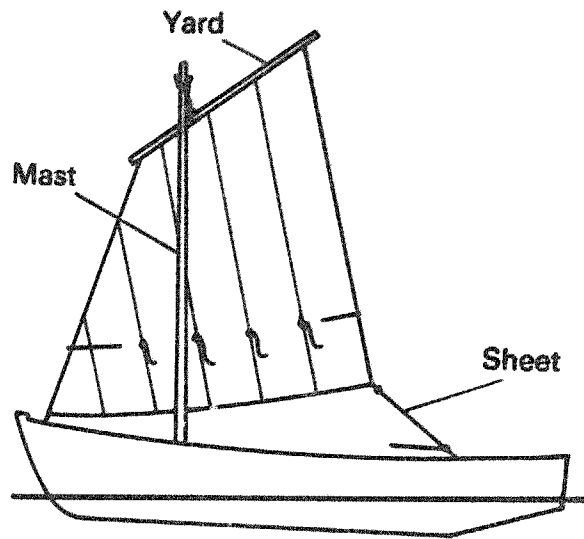

### Mast and Rigging

The mast does not have standing rigging, but the halyard is tied to the edge of the boat; this gives side support to the mast when the sail is up. The mast should be held firmly upright by the mast step and by the lashings round the cross-member or by the hole in the deck.

- Spar** The spar at the top of the sail needs to be stiff and light, and should be thickest in the middle. It is best made from one piece of wood, but several pieces can be used if they are strongly lashed together (see page 51). A boom is sometimes used when sailing away from the wind.
- Sail** The top edge of the sail is laced to the spar, using Method 1 (see page 69). The other three edges do not have spars. The lower front corner of the sail is tied to the front of the boat.
- Halyard** The sail is hoisted by a single rope halyard. This should be tied to the spar about one-third of the spar length from the front of the spar. When hoisted, the halyard is tied to a belaying pin (or a cleat), which should be close to the outside edge of the boat. This helps support the mast on the side from which the wind is blowing when the boat is sailing. Because the rig needs to be lowered and raised whilst sailing, it is usual to make the loads on the halyard less by using a purchase. This is described on page 55.
- Sail Control** The angle of the sail is controlled by a rope (or sheet) on the lower rear corner of the sail. A further rope is tied to the front lower corner of the sail; this is used to pull the front edge of the sail tight.

**Handling**

When tacking or gybing, the sail needs to be partly lowered.

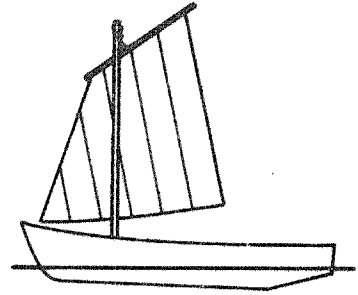

Then the forward control line is let go and the sail and the front of the spar are pulled round behind the mast.

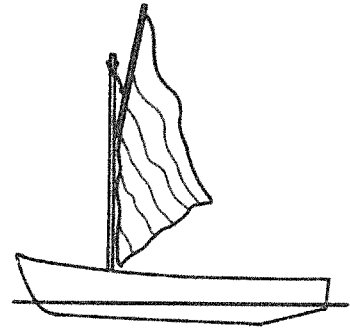

Then the forward line is retied, the sail is hoisted again, and the halyard is retied on the side of the boat which is facing the wind.

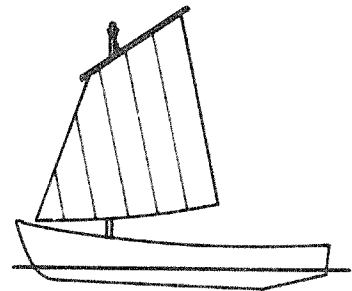

This makes the Dipping Lug rig more work to handle than some other sailing rigs.

**Reefing**

The sail can be reduced in strong winds by lowering the spar and tying the excess at the bottom edge.

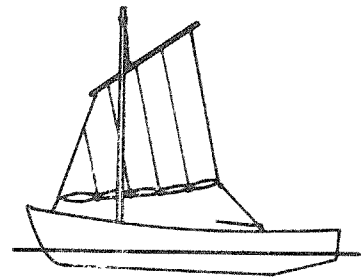
**Stowing**

The sail is stowed on deck when not in use, but takes up little space as the spar is short.

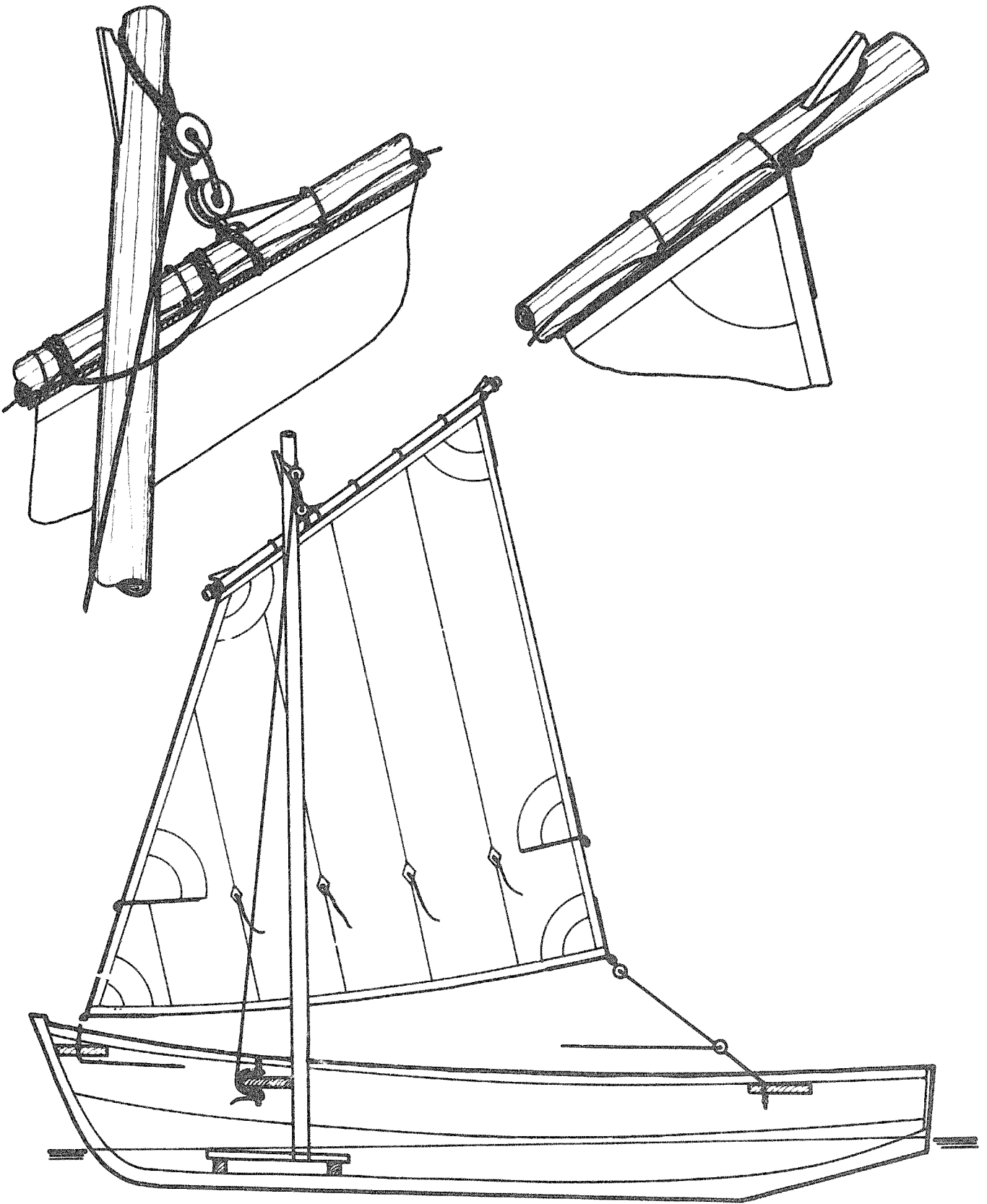



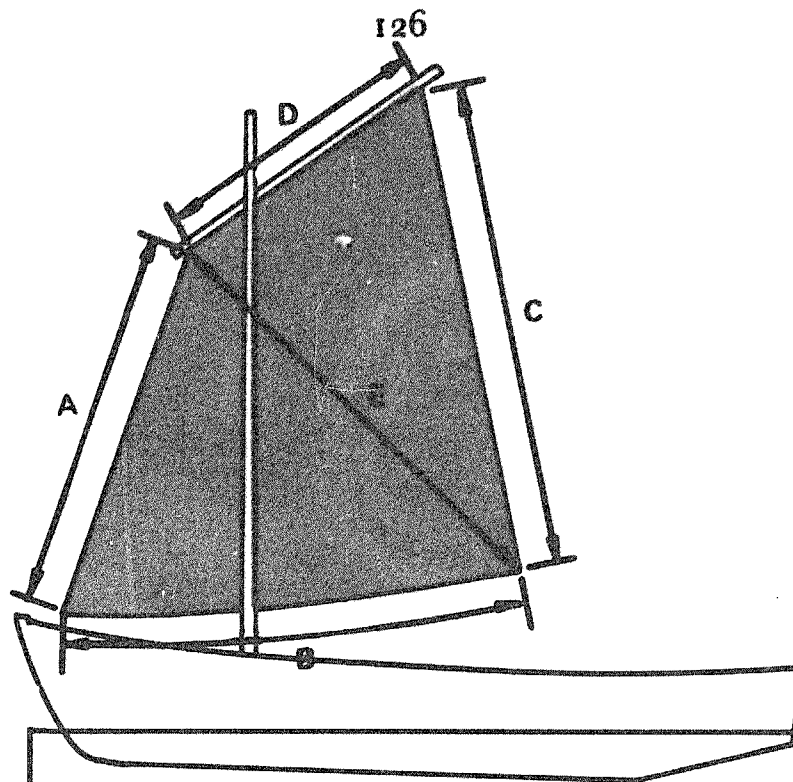

## SAILS AND RUNNING RIGGING

### ACCURATE DIMENSIONS for laying out Sail Plans

SAIL AREA	SAIL length of sides				
	A	B	C	D	E
5	2.6	2.7	3.1	1.6	3.4
10	3.2	3.8	4.2	2.5	4.2
15	3.8	4.7	5	3	4.9
20	4.5	5.4	5.8	3.3	5.9
25	5	6	6.4	3.7	6.5
30	5.5	6.6	7	4	7.2
35	6	7.1	7.5	4.3	7.8
40	6.3	7.6	8.1	4.6	8.2
45	6.7	8	8.5	4.8	8.7
Square metres	metres	metres	metres	metres	metres

### APPROXIMATE DIMENSIONS for estimating materials

HALYARD		SHEET	
L	D	L	D
8	8	7	8
10.5	8	10	8
12.5	8	12	8
14.5	10	14	10
16	10	15	10
17.5	10	17	10
19	12	18	12
20	12	19	12
22	12	20	12
metres	milli- metres	metres	milli- metres

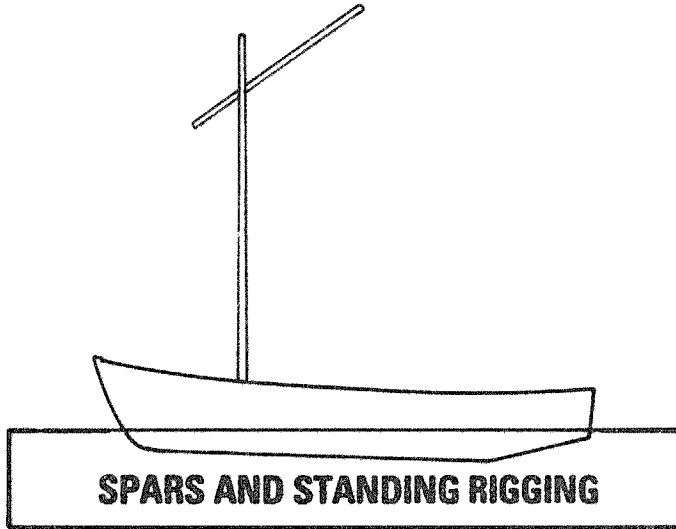

**Note 1:** Measure the depth inside the hull and add this to the mast length in the table below. This gives the total mast length.

**APPROXIMATE DIMENSIONS  
for estimating materials needed**

SAIL AREA	MAST		SPAR	
	L	D	L	D
5	3.5	70 - 100	1.75	30 - 50
10	4.6	90 - 120	2.8	30 - 50
15	5.6	90 - 120	3.4	40 - 60
20	6.3	100 - 130	3.7	40 - 60
25	6.7	100 - 130	4.2	40 - 60
30	7.3	110 - 140	4.5	50 - 70
35	7.6	110 - 140	4.8	50 - 70
40	8	120 - 150	5.2	60 - 80
45	8.5	120 - 150	5.4	60 - 80
square metres	metres	millimetres	metres	millimetres

**Note 2:** Before cutting spars and rigging materials, lay out the components on the ground to check that lengths are adequate.

## APPENDIX 8 - THE JIB

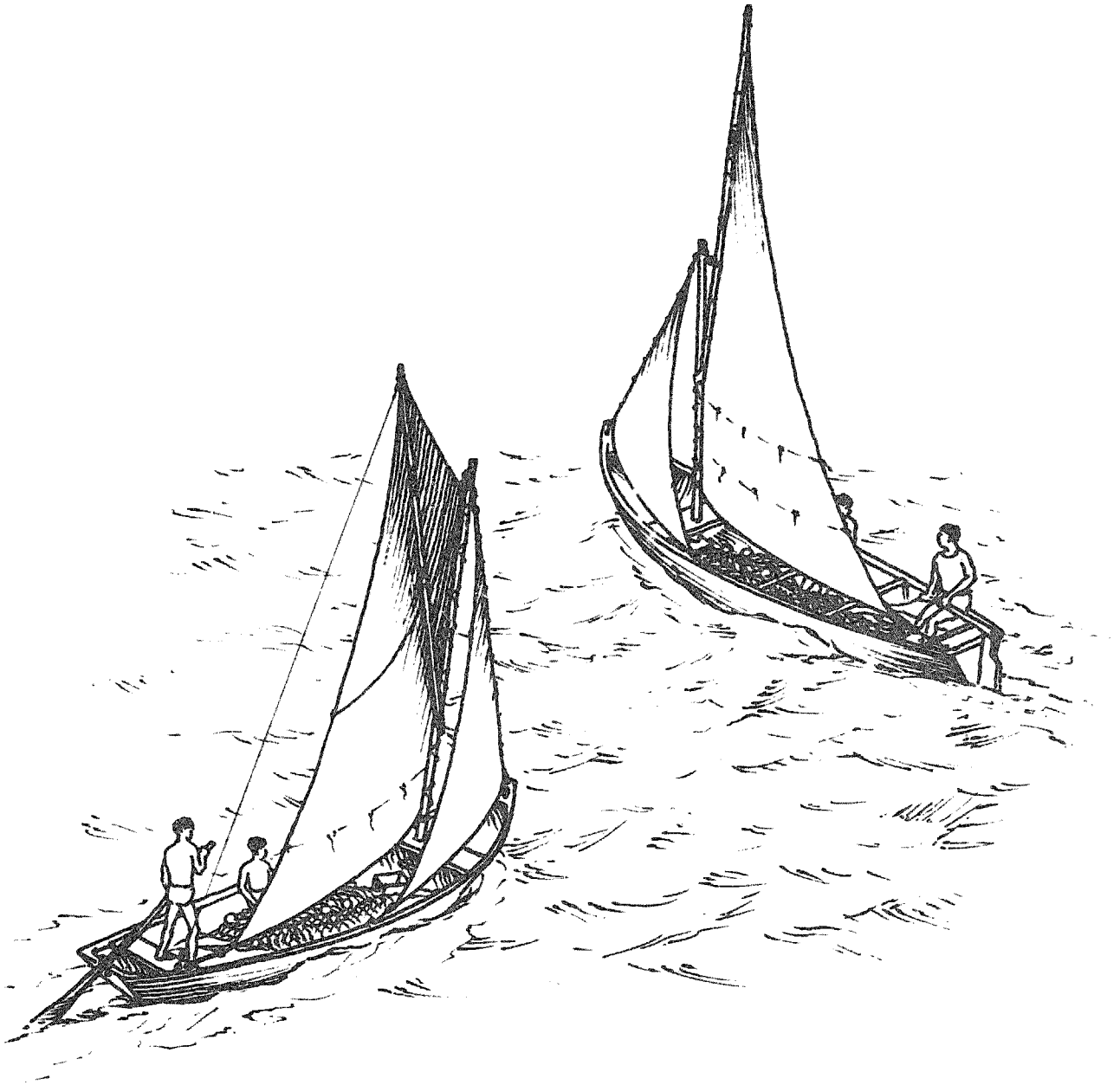

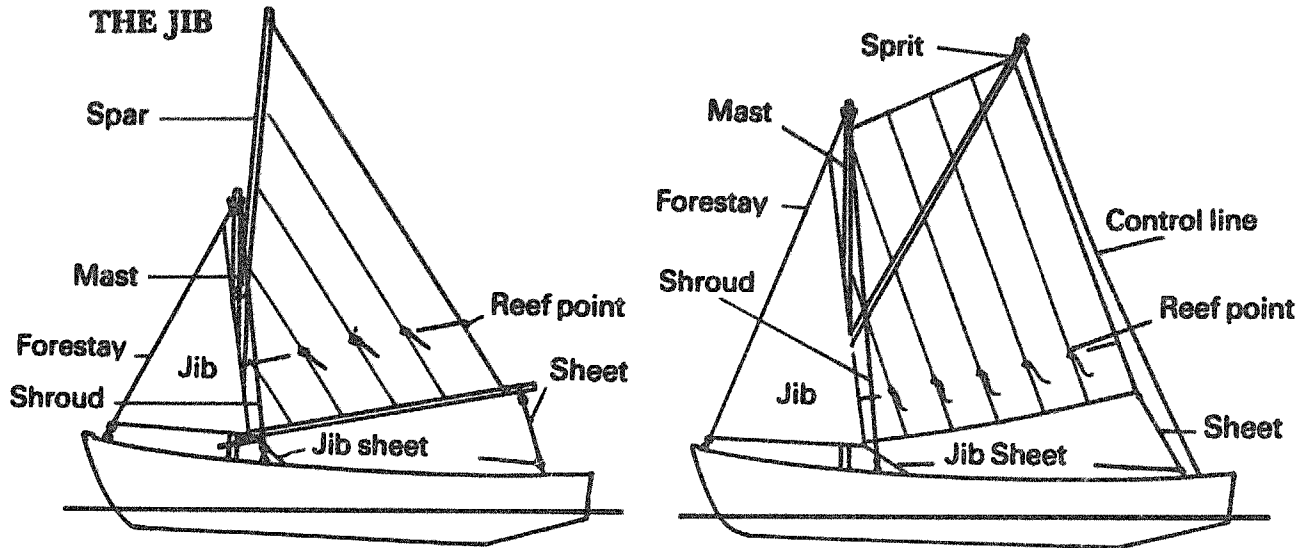

The jib, or foresail, is a three-sided sail carried in front of the mast. It may be used on both Gunter and Sprit rigs.

The advantages of a jib are:

- (1) It gives improved performance to the boat when sailing into the wind. Usually the boat will be able to sail closer to the direction from which the wind is blowing.
- (2) It is a very simple and quick method of increasing the amount of sail when sailing away from the wind.

The sail is fixed to the *forestay* along its front edge; this is done with short lengths of line tied around the forestay which allows the sail to slide up and down. The bottom corner at the front is tied to the boat so that the front edge pulls tight when the sail is hoisted. The sail does not need any extra spars to spread it.

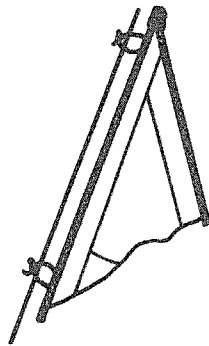

To hoist the jib, the halyard is attached to the top corner, led through a deadeye on the front of the mast, and tied to a cleat on the cross-member supporting the mast.

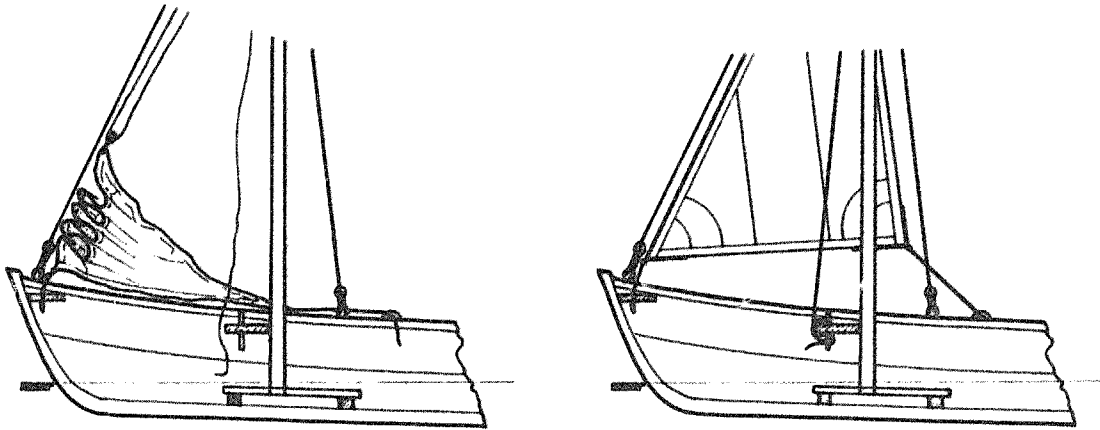

The sail is controlled by two sheets, leading each side of the mast, and through sheet points on the boat. When the boat is tacked or gybed, the jib is changed from one side to the other, using these sheets.

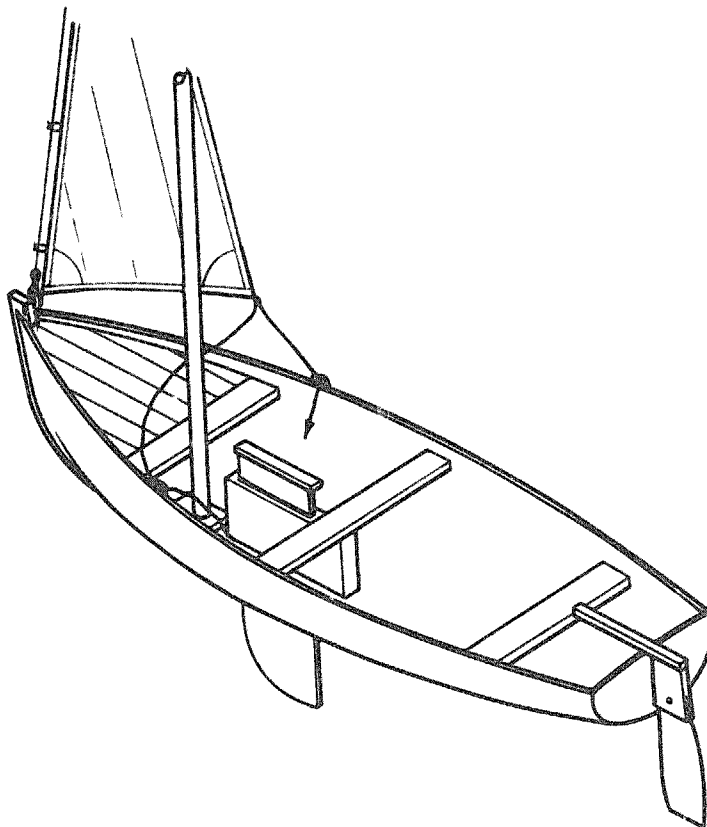

When not in use, the jib should be lowered into the boat. The sail is not reefed, but in strong winds can be lowered to reduce the sail area of the boat.

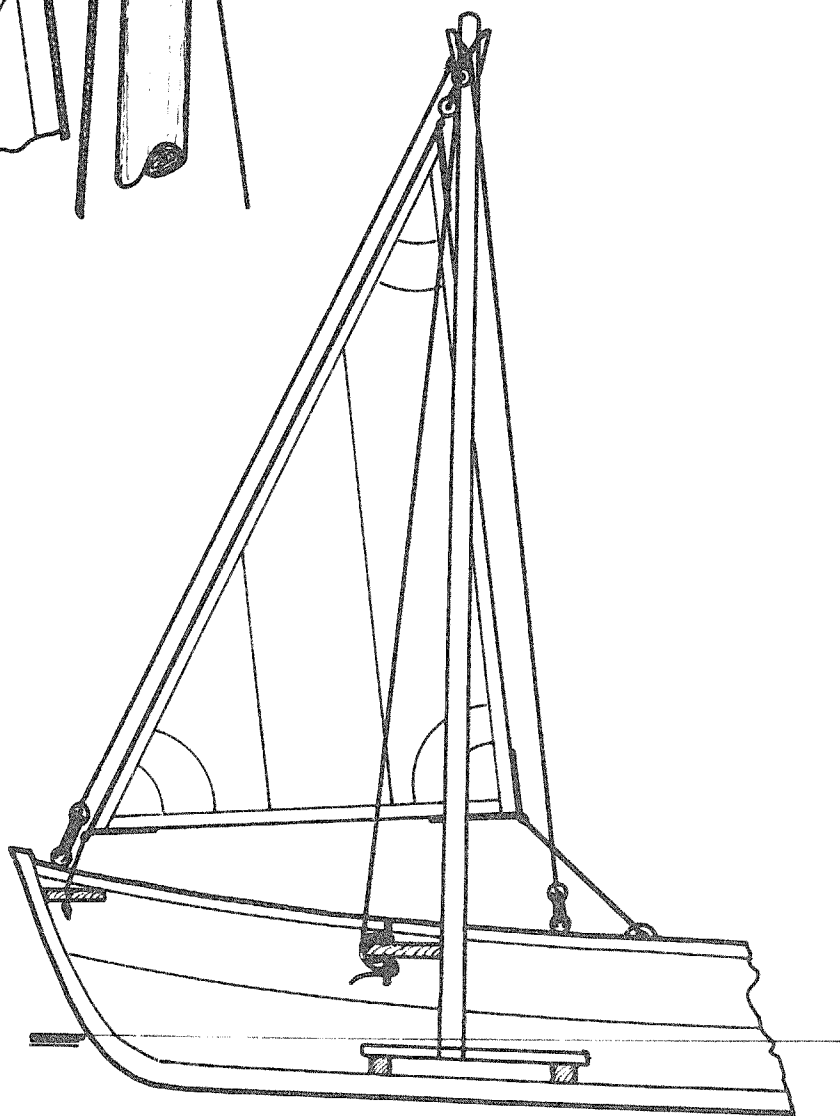
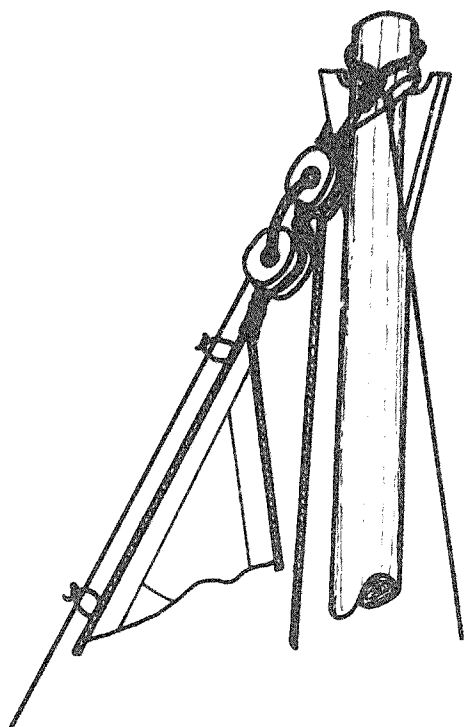

**THE JIB, WITH SPRIT RIG**

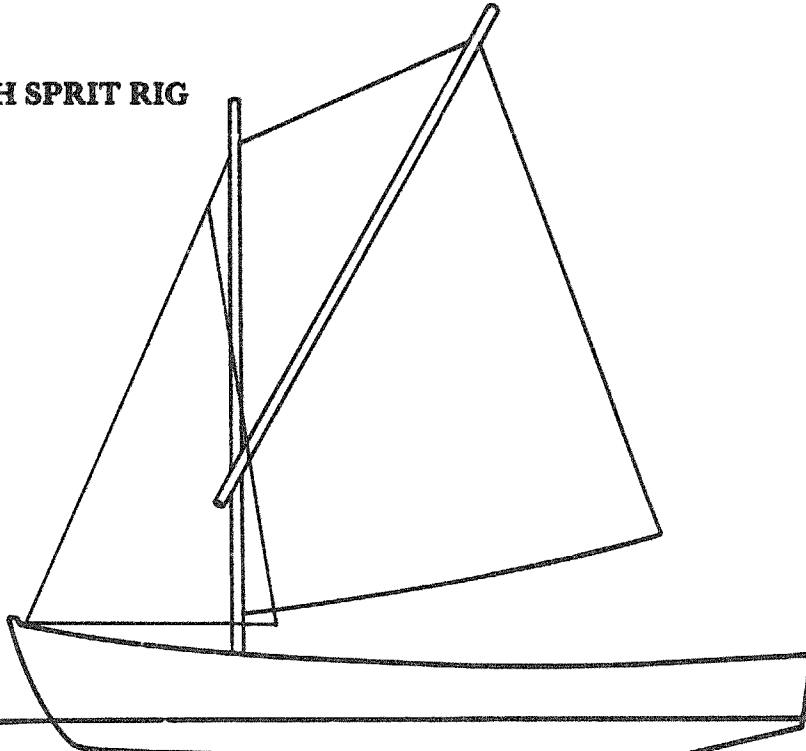
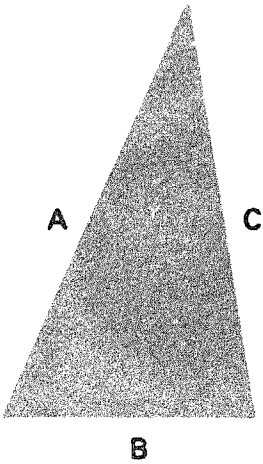

Sail Area - Existing, without jib

Sheet Length - Allows for both sides

**ACCURATE DIMENSIONS**  
for laying out  
Sail Plans

**APPROXIMATE DIMENSIONS**  
for estimating  
materials

SAIL AREA	JIB Lengths of sides			HALYARD		SHEET	
	A	B	C	L	D	L	D
5	3.2	1.6	2.7	10	8	3.5	8
10	4.2	2.1	3.6	12	8	4	8
15	4.8	2.4	4.1	14	8	5	8
20	5.4	2.7	4.6	16	10	6	10
25	6	3	5.1	18	10	6.5	10
30	6.5	3.25	5.5	19	10	7	10
35	7	3.5	6	21	12	7.5	12
40	7.4	3.7	6.3	22	12	8	12
45	7.7	3.85	6.5	23	12	8.5	12
Square metres	metres	metres	metres	metres	milli-metres	metres	milli-metres

**THE JIB, WITH GUNTER RIG**

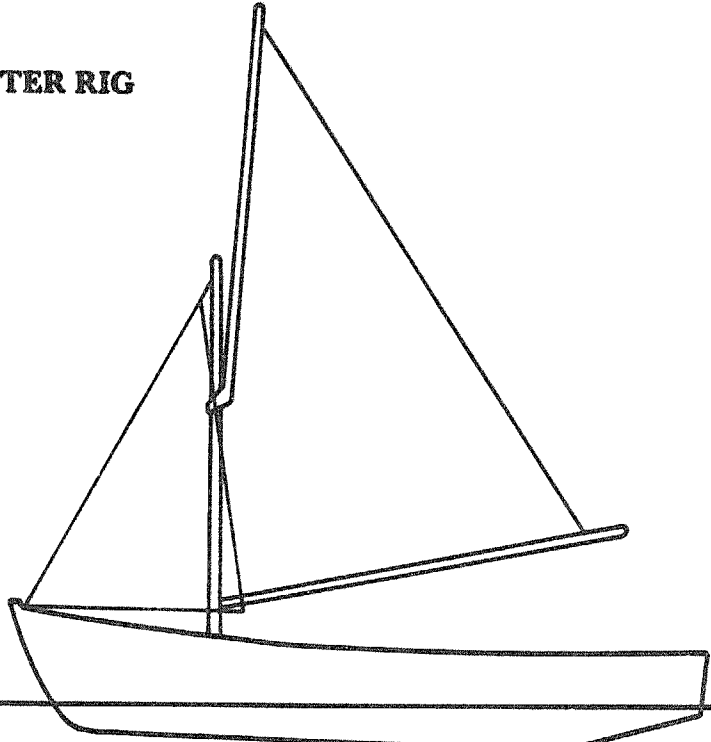
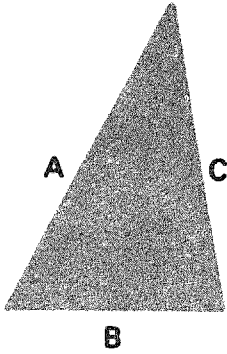

Sail Area - Existing, without jib				ACCURATE DIMENSIONS for laying out Sail Plans				Sheet Length - Allows for both sides			
				JTB lengths of sides				APPROXIMATE DIMENSIONS for estimating materials			
SAIL AREA				HALYARD		SHEET					
	A	B	C	L	D	L	D				
5	2.8	1.6	2.1	9	8	3.5	8				
10	3.7	2.1	2.8	11	8	4	8				
15	4.3	2.5	3.3	13	8	5	8				
20	5	2.9	3.8	15	10	6	10				
25	5.6	3.2	4.2	17	10	6.5	10				
30	6.1	3.5	4.6	18	10	7	10				
35	6.7	3.8	5.1	20	12	7.5	12				
40	7	4.1	5.3	21	12	8	12				
45	7.5	4.4	5.7	22	12	8.5	12				
Square metres	metres	metres	metres	metres	milli-metres	metres	milli-metres				



# **APPENDIX 9 – CONVERSION TABLES**

- (1) Beaufort Scale to Knots to Metres/Second to Km/Hour.
- (2) Square Metres to Square Yards to Square Feet.
- (3) Metres to Feet and Inches.
- (4) Millimetres to Inches.

## 1. Beaufort Scale to Knots to Metres/Second to Km/Hour.

Beaufort Scale (force)	Knots	Metres/Second	Kilometres/hour
1	1 - 3	0.3 - 1.5	1 - 5
2	4 - 6	1.6 - 3.3	6 - 11
3 light wind	7 - 10	3.4 - 5.4	12 - 19
4 Medium wind	11 - 16	5.5 - 7.9	20 - 29
5	17 - 21	8.0 - 10.7	30 - 38
6 Strong wind	22 - 27	10.8 - 13.8	39 - 50
7	28 - 33	13.9 - 17.1	51 - 61
8 Gale	34 - 40	17.2 - 20.7	62 - 74
9	41 - 47	20.8 - 24.4	75 - 87
10 Storm	48 - 55	24.5 - 28.4	88 - 101
11	56 - 63	28.5 - 32.6	102 - 116
12 Hurricane	64 - 71	32.7 - 36.9	117 - 132

**2. Square Metres to Square Yards to Square Feet.**

Square metres	Square yards (approx)	Square Feet (approx)
5	6	54
10	12	108
15	18	161
20	24	215
25	30	269
30	36	323
35	42	377
40	48	431
45	54	484

## 3. Metres to Feet and Inches.

	Approximate	
	feet	Inches
0.5	1	$7\frac{1}{2}$
1	3	$3\frac{1}{4}$
2	6	$6\frac{3}{4}$
4	13	$1\frac{1}{2}$
6	19	$8\frac{1}{4}$
8	26	3
10	32	$9\frac{3}{4}$
12	39	$4\frac{1}{2}$
14	45	11
16	52	6
18	59	$0\frac{3}{4}$
20	65	$7\frac{1}{2}$

## 4. Millimetres to Inches.

Milli- metres	Approx inches
6	$\frac{1}{4}$
12.5	$\frac{1}{2}$
25	1
50	2
75	3
100	4
150	6
200	8
300	12
500	20