

CAP AND SET SCREWS

Slotted Head Cap Screws.—American National Standard ANSI/ASME B18.6.2-1998 is intended to cover the complete general and dimensional data for the various styles of slotted head cap screws as well as square head and slotted headless set screws (see page 1606). Reference should be made to this Standard for information or data not found in the following text or tables.

Length of Thread: The length of complete (full form) thread on cap screws is equal to twice the basic screw diameter plus 0.250 in. with a plus tolerance of 0.188 in. or an amount equal to $2\frac{1}{2}$ times the pitch of the thread, whichever is greater. Cap screws of lengths too short to accommodate the minimum thread length have full form threads extending to within a distance equal to $2\frac{1}{2}$ pitches (threads) of the head.

Designation: Slotted head cap screws are designated by the following data in the sequence shown: Nominal size (fraction or decimal equivalent); threads per inch; screw length (fraction or decimal equivalent); product name; material; and protective finish, if required. Examples: $\frac{1}{2}$ -13 \times 3 Slotted Round Head Cap Screw, SAE Grade 2 Steel, Zinc Plated. .750-16 \times 2.25 Slotted Flat Countersunk Head Cap Screw, Corrosion Resistant Steel.

Table 1. American National Standard Slotted Flat Countersunk Head Cap Screws
ANSI/ASME B18.6.2-1998

Nominal Size ^a or Basic Screw Diam.	Body Diam., E		Head Dia., A		Head Hgt., H	Slot Width, J		Slot Depth, T		Fillet Rad., U	
			Edge Sharp	Edge Rnd'd. or Flat							
	Max.	Min.	Max.	Min.		Ref.	Max.	Min.	Max.		Min.
$\frac{1}{4}$	0.2500	.2500	.2450	.500	.452	.140	.075	.064	.068	.045	.100
$\frac{3}{16}$	0.3125	.3125	.3070	.625	.567	.177	.084	.072	.086	.057	.125
$\frac{3}{8}$	0.3750	.3750	.3690	.750	.682	.210	.094	.081	.103	.068	.150
$\frac{7}{16}$	0.4375	.4375	.4310	.812	.736	.210	.094	.081	.103	.068	.175
$\frac{1}{2}$	0.5000	.5000	.4930	.875	.791	.210	.106	.091	.103	.068	.200
$\frac{5}{16}$	0.5625	.5625	.5550	1.000	.906	.244	.118	.102	.120	.080	.225
$\frac{3}{8}$	0.6250	.6250	.6170	1.125	1.020	.281	.133	.116	.137	.091	.250
$\frac{3}{4}$	0.7500	.7500	.7420	1.375	1.251	.352	.149	.131	.171	.115	.300
$\frac{7}{8}$	0.8750	.8750	.8660	1.625	1.480	.423	.167	.147	.206	.138	.350
1	1.0000	1.0000	.9900	1.875	1.711	.494	.188	.166	.240	.162	.400
$1\frac{1}{8}$	1.1250	1.1250	1.1140	2.062	1.880	.529	.196	.178	.257	.173	.450
$1\frac{1}{4}$	1.2500	1.2500	1.2390	2.312	2.110	.600	.211	.193	.291	.197	.500
$1\frac{3}{8}$	1.3750	1.3750	1.3630	2.562	2.340	.665	.226	.208	.326	.220	.550
$1\frac{1}{2}$	1.5000	1.5000	1.4880	2.812	2.570	.742	.258	.240	.360	.244	.600

^a When specifying a nominal size in decimals, the zero preceding the decimal point is omitted as is any zero in the fourth decimal place.

All dimensions are in inches.

Threads: Threads are Unified Standard Class 2A; UNC, UNF and 8 UN Series or UNRC, UNRF, and 8 UNR Series.

Table 2. American National Standard Slotted Round Head Cap Screws
ANSI/ASME B18.6.2-1998

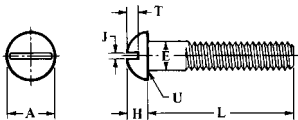

Nom. Size ^a or Basic Screw Diameter	Body Diameter, <i>E</i>		Head Diameter, <i>A</i>		Head Height, <i>H</i>		Slot Width, <i>J</i>		Slot Depth, <i>T</i>		
	Max.	Min.	Max.	Min.	Max.	Min.	Max.	Min.	Max.	Min.	
1/4	0.2500	.2500	.2450	.437	.418	.191	.175	.075	.064	.117	.097
3/16	0.3125	.3125	.3070	.562	.540	.245	.226	.084	.072	.151	.126
3/8	0.3750	.3750	.3690	.625	.603	.273	.252	.094	.081	.168	.138
7/16	0.4375	.4375	.4310	.750	.725	.328	.302	.094	.081	.202	.167
1/2	0.5000	.5000	.4930	.812	.786	.354	.327	.106	.091	.218	.178
9/16	0.5625	.5625	.5550	.937	.909	.409	.378	.118	.102	.252	.207
5/8	0.6250	.6250	.6170	1.000	.970	.437	.405	.133	.116	.270	.220
3/4	0.7500	.7500	.7420	1.250	1.215	.546	.507	.149	.131	.338	.278

^a When specifying a nominal size in decimals, the zero preceding the decimal point is omitted as is any zero in the fourth decimal place.

All dimensions are in inches.

Fillet Radius, U: For fillet radius see footnote to table below.

Threads: Threads are Unified Standard Class 2A; UNC, UNF and 8 UN Series or UNRC, UNRF and 8 UNR Series.

Table 3. American National Standard Slotted Fillister Head Cap Screws
ANSI/ASME B18.6.2-1998

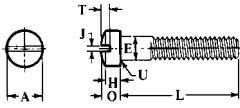

Nom. Size ^a or Basic Screw Dia.	Body Dia., <i>E</i>		Head Dia., <i>A</i>		Head Side Height, <i>H</i>		Total Head Height, <i>O</i>		Slot Width, <i>J</i>		Slot Depth, <i>T</i>		
	Max.	Min.	Max.	Min.	Max.	Min.	Max.	Min.	Max.	Min.	Max.	Min.	
1/4	0.2500	.2500	.2450	.375	.363	.172	.157	.216	.194	.075	.064	.097	.077
3/16	0.3125	.3125	.3070	.437	.424	.203	.186	.253	.230	.084	.072	.115	.090
3/8	0.3750	.3750	.3690	.562	.547	.250	.229	.314	.284	.094	.081	.142	.112
7/16	0.4375	.4375	.4310	.625	.608	.297	.274	.368	.336	.094	.081	.168	.133
1/2	0.5000	.5000	.4930	.750	.731	.328	.301	.413	.376	.106	.091	.193	.153
9/16	0.5625	.5625	.5550	.812	.792	.375	.346	.467	.427	.118	.102	.213	.168
5/8	0.6250	.6250	.6170	.875	.853	.422	.391	.521	.478	.133	.116	.239	.189
3/4	0.7500	.7500	.7420	1.000	.976	.500	.466	.612	.566	.149	.131	.283	.223
7/8	0.8750	.8750	.8660	1.125	1.098	.594	.556	.720	.668	.167	.147	.334	.264
1	1.0000	1.0000	.9900	1.312	1.282	.656	.612	.803	.743	.188	.166	.371	.291

^a When specifying nominal size in decimals, the zero preceding the decimal point is omitted as is any zero in the fourth decimal place.

All dimensions are in inches.

Fillet Radius, U: The fillet radius is as follows: For screw sizes 1/4 to 3/8 incl., .031 max. and .016 min.; 7/16 to 9/16 incl., .047 max., .016 min.; and for 5/8 to 1, incl., .062 max., .031 min.

Threads: Threads are Unified Standard Class 2A; UNC, UNF and 8 UN Series or UNRC, UNRF and 8 UNR Series.

Table 4. American National Standard Hexagon and Spline Socket Head Cap Screws ANSI/ASME B18.3-1998

Nominal Size	Body Diameter,		Head Diameter,		Head Height,		Spline Socket Size	Hex. Socket Size	Fillet Ext.	Key Engagement ^a
	Max	Min	Max	Min	Max	Min	Nom	Nom	Max	T
	D		A		H		M	J	F	T
0	0.0600	0.0568	0.096	0.091	0.060	0.057	0.060	0.050	0.007	0.025
1	0.0730	0.0695	0.118	0.112	0.073	0.070	0.072	0.007	0.007	0.031
2	0.0860	0.0822	0.140	0.134	0.086	0.083	0.096	3/64	0.078	0.038
3	0.0990	0.0949	0.161	0.154	0.099	0.095	0.096	3/64	0.078	0.044
4	0.1120	0.1075	0.183	0.176	0.112	0.108	0.111	3/32	0.094	0.051
5	0.1250	0.1202	0.205	0.198	0.125	0.121	0.111	3/32	0.094	0.057
6	0.1380	0.1329	0.226	0.218	0.138	0.134	0.133	3/32	0.109	0.064
8	0.1640	0.1585	0.270	0.262	0.164	0.159	0.168	3/16	0.141	0.077
10	0.1900	0.1840	0.312	0.303	0.190	0.185	0.183	3/16	0.156	0.090
1/4	0.2500	0.2435	0.375	0.365	0.250	0.244	0.216	3/16	0.188	0.120
3/16	0.3125	0.3053	0.469	0.457	0.312	0.306	0.291	1/4	0.250	0.151
1/2	0.3750	0.3678	0.562	0.550	0.375	0.368	0.372	3/16	0.312	0.182
5/16	0.4375	0.4294	0.656	0.642	0.438	0.430	0.454	3/16	0.375	0.213
3/8	0.5000	0.4919	0.750	0.735	0.500	0.492	0.454	3/8	0.375	0.245
7/8	0.6250	0.6163	0.938	0.921	0.625	0.616	0.595	1/2	0.500	0.307
1	0.7500	0.7406	1.125	1.107	0.750	0.740	0.620	3/8	0.625	0.370
3/8	0.8750	0.8647	1.312	1.293	0.875	0.864	0.698	3/4	0.750	0.432
1	1.0000	0.9886	1.500	1.479	1.000	0.988	0.790	3/4	0.750	0.495
1 1/8	1.1250	1.1086	1.688	1.665	1.125	1.111	...	7/8	0.875	0.557
1 1/4	1.2500	1.2336	1.875	1.852	1.250	1.236	...	1	0.875	0.620
1 3/8	1.3750	1.3568	2.062	2.038	1.375	1.360	...	1	1.000	0.682
1 1/2	1.5000	1.4818	2.250	2.224	1.500	1.485	...	1	1.000	0.745
1 3/4	1.7500	1.7295	2.625	2.597	1.750	1.734	...	1 1/4	1.250	0.880
2	2.0000	1.9780	3.000	2.970	2.000	1.983	...	1 1/2	1.500	0.995
2 1/4	2.2500	2.2280	3.375	3.344	2.250	2.232	...	1 3/4	1.750	1.120
2 1/2	2.5000	2.4762	3.750	3.717	2.500	2.481	...	1 3/4	1.750	1.245
2 3/4	2.7500	2.7262	4.125	4.090	2.750	2.730	...	2	2.000	1.370
3	3.0000	2.9762	4.500	4.464	3.000	2.979	...	2 1/4	2.250	1.495
3 1/4	3.2500	3.2262	4.875	4.837	3.250	3.228	...	2 1/4	2.250	1.620
3 1/2	3.5000	3.4762	5.250	5.211	3.500	3.478	...	2 3/4	2.750	1.745
3 3/4	3.7500	3.7262	5.625	5.584	3.750	3.727	...	2 3/4	2.750	1.870
4	4.0000	3.9762	6.000	5.958	4.000	3.976	...	3	3.000	1.995

^a(Key engagement depths are minimum.)

All dimensions in inches. The body length L_B of the screw is the length of the unthreaded cylindrical portion of the shank. The length of thread, L_T , is the distance from the extreme point to the last complete (full form) thread. Standard length increments for screw diameters up to 1 inch are 1/16 inch for lengths 1/8 through 1/4 inch, 1/8 inch for lengths 1/4 through 1 inch, 1/4 inch for lengths 1 through 3 1/2 inches, 1/2 inch for lengths 3 1/2 through 7 inches, 1 inch for lengths 7 through 10 inches and for diameters over 1 inch are 1/2 inch for lengths 1 through 7 inches, 1 inch for lengths 7 through 10 inches, and 2 inches for lengths over 10 inches. Heads may be plain or knurled, and chamfered to an angle E of 30 to 45 degrees with the surface of the flat. The thread conforms to the Unified Standard with radius root, Class 3A UNRC and UNRF for screw sizes No. 0 through 1 inch inclusive, Class 2A UNRC and UNRF for over 1 inch through 1 1/2 inches inclusive, and Class 2A UNRC for larger sizes. Socket dimensions are given in Table 11. For details not shown, including materials, see ANSI/ASME B18.3-1998.

Table 5. Drill and Counterbore Sizes For Socket Head Cap Screws (1960 Series)

Nominal Size or Basic Screw Diameter	Nominal Drill Size				Counterbore Diameter	Countersink Diameter ^a	
	Close Fit ^b		Normal Fit ^c				
	Number or Fractional Size	Decimal Size	Number or Fractional Size	Decimal Size			
	A						B
0	0.0600	51	0.067	49	0.073	$\frac{1}{8}$	0.074
1	0.0730	46	0.081	43	0.089	$\frac{5}{32}$	0.087
2	0.0860	$\frac{3}{32}$	0.094	36	0.106	$\frac{3}{16}$	0.102
3	0.0990	36	0.106	31	0.120	$\frac{7}{32}$	0.115
4	0.1120	$\frac{1}{8}$	0.125	29	0.136	$\frac{7}{32}$	0.130
5	0.1250	$\frac{5}{64}$	0.141	23	0.154	$\frac{1}{4}$	0.145
6	0.1380	23	0.154	18	0.170	$\frac{9}{32}$	0.158
8	0.1640	15	0.180	10	0.194	$\frac{3}{8}$	0.188
10	0.1900	5	0.206	2	0.221	$\frac{3}{8}$	0.218
$\frac{1}{4}$	0.2500	$\frac{17}{64}$	0.266	$\frac{9}{32}$	0.281	$\frac{7}{16}$	0.278
$\frac{5}{16}$	0.3125	$\frac{21}{64}$	0.328	$\frac{11}{32}$	0.344	$\frac{17}{32}$	0.346
$\frac{3}{8}$	0.3750	$\frac{25}{64}$	0.391	$\frac{13}{32}$	0.406	$\frac{5}{8}$	0.415
$\frac{7}{16}$	0.4375	$\frac{29}{64}$	0.453	$\frac{15}{32}$	0.469	$\frac{23}{32}$	0.483
$\frac{1}{2}$	0.5000	$\frac{33}{64}$	0.516	$\frac{17}{32}$	0.531	$\frac{13}{16}$	0.552
$\frac{5}{8}$	0.6250	$\frac{41}{64}$	0.641	$\frac{21}{32}$	0.656	1	0.689
$\frac{3}{4}$	0.7500	$\frac{49}{64}$	0.766	$\frac{25}{32}$	0.781	$\frac{13}{16}$	0.828
$\frac{7}{8}$	0.8750	$\frac{57}{64}$	0.891	$\frac{29}{32}$	0.906	$\frac{13}{8}$	0.963
1	1.0000	$\frac{11}{64}$	1.016	$\frac{11}{32}$	1.031	$\frac{13}{8}$	1.100
$1\frac{1}{4}$	1.2500	$1\frac{1}{32}$	1.281	$1\frac{5}{16}$	1.312	2	1.370
$1\frac{1}{2}$	1.5000	$1\frac{17}{32}$	1.531	$1\frac{9}{16}$	1.562	$2\frac{3}{8}$	1.640
$1\frac{3}{4}$	1.7500	$1\frac{25}{32}$	1.781	$1\frac{13}{16}$	1.812	$2\frac{3}{4}$	1.910
2	2.0000	$2\frac{1}{32}$	2.031	$2\frac{1}{16}$	2.062	$3\frac{1}{8}$	2.180

^a *Countersink*: It is considered good practice to countersink or break the edges of holes which are smaller than $(D \text{ Max} + 2F \text{ Max})$ in parts having a hardness which approaches, equals or exceeds the screw hardness. If such holes are not countersunk, the heads of screws may not seat properly or the sharp edges on holes may deform the fillets on screws thereby making them susceptible to fatigue in applications involving dynamic loading. The countersink or corner relief, however, should not be larger than is necessary to insure that the fillet on the screw is cleared.

^b *Close Fit*: The close fit is normally limited to holes for those lengths of screws which are threaded to the head in assemblies where only one screw is to be used or where two or more screws are to be used and the mating holes are to be produced either at assembly or by matched and coordinated tooling.

^c *Normal Fit*: The normal fit is intended for screws of relatively long length or for assemblies involving two or more screws where the mating holes are to be produced by conventional tolerancing methods. It provides for the maximum allowable eccentricity of the longest standard screws and for certain variations in the parts to be fastened, such as: deviations in hole straightness, angularity between the axis of the tapped hole and that of the hole for the shank, differences in center distances of the mating holes, etc.

All dimensions in inches.

Source: Appendix to American National Standard ANSI/ASME B18.3-1998.

Table 6. American National Standard Hexagon and Spline Socket Flat Countersunk Head Cap Screws ANSI/ASME B18.3-1998

Nominal Size	Body Diam.		Head Diameter		Head-Height Reference	Spline Socket Size	Hexagon Socket Size	Key Engagement
	Max.	Min.	Theoretical Sharp	Abs. Min.			Nom.	Min.
	D		A		H	M	J	T
0	0.0600	0.0568	0.138	0.117	0.044	0.048	0.035	0.025
1	0.0730	0.0695	0.168	0.143	0.054	0.060	0.050	0.031
2	0.0860	0.0822	0.197	0.168	0.064	0.060	0.050	0.038
3	0.0990	0.0949	0.226	0.193	0.073	0.072	1/16	0.044
4	0.1120	0.1075	0.255	0.218	0.083	0.072	1/16	0.055
5	0.1250	0.1202	0.281	0.240	0.090	0.096	5/64	0.061
6	0.1380	0.1329	0.307	0.263	0.097	0.096	5/64	0.066
8	0.1640	0.1585	0.359	0.311	0.112	0.111	3/32	0.076
10	0.1900	0.1840	0.411	0.359	0.127	0.145	1/8	0.087
1/4	0.2500	0.2435	0.531	0.480	0.161	0.183	5/32	0.111
5/16	0.3125	0.3053	0.656	0.600	0.198	0.216	3/16	0.135
3/8	0.3750	0.3678	0.781	0.720	0.234	0.251	7/32	0.159
7/16	0.4375	0.4294	0.844	0.781	0.234	0.291	1/4	0.159
1/2	0.5000	0.4919	0.938	0.872	0.251	0.372	5/16	0.172
5/8	0.6250	0.6163	1.188	1.112	0.324	0.454	3/8	0.220
3/4	0.7500	0.7406	1.438	1.355	0.396	0.454	1/2	0.220
7/8	0.8750	0.8647	1.688	1.604	0.468	...	5/16	0.248
1	1.0000	0.9886	1.938	1.841	0.540	...	1/8	0.297
1 1/8	1.1250	1.1086	2.188	2.079	0.611	...	3/4	0.325
1 1/4	1.2500	1.2336	2.438	2.316	0.683	...	7/8	0.358
1 3/8	1.3750	1.3568	2.688	2.553	0.755	...	7/8	0.402
1 1/2	1.5000	1.4818	2.938	2.791	0.827	...	1	0.435

All dimensions in inches.

The body of the screw is the unthreaded cylindrical portion of the shank where not threaded to the head; the shank being the portion of the screw from the point of juncture of the conical bearing surface and the body to the flat of the point. The length of thread L_T is the distance measured from the extreme point to the last complete (full form) thread.

Standard length increments of No. 0 through 1-inch sizes are as follows: 1/16 inch for nominal screw lengths of 1/8 through 1/4 inch; 1/8 inch for lengths of 1/4 through 1 inch; 1/4 inch for lengths of 1 inch through 3 1/2 inches; 1/2 inch for lengths of 3 1/2 through 7 inches; and 1 inch for lengths of 7 through 10 inches, incl. For screw sizes over 1 inch, length increments are: 1/2 inch for nominal screw lengths of 1 inch through 7 inches; 1 inch for lengths of 7 through 10 inches; and 2 inches for lengths over 10 inches.

Threads shall be Unified external threads with radius root; Class 3A UNRC and UNRF series for sizes No. 0 through 1 inch and Class 2A UNRC and UNRF series for sizes over 1 inch to 1 1/2 inches, incl.

For manufacturing details not shown, including materials, see American National Standard ANSI/ASME B18.3-1998 Socket dimensions are given in Table 11.

Table 7. American National Standard Hexagon Socket and Spline Socket Button Head Cap Screws ANSI/ASME B18.3-1998

Nominal Size	Screw Diameter	Head Diameter		Head Height		Head Side Height	Spline Socket Size ^a	Hexagon Socket Size ^a	Standard Length
	Basic	Max.	Min.	Max.	Min.	Ref.	Nom.	Nom.	Max.
	<i>D</i>	<i>A</i>		<i>H</i>		<i>S</i>	<i>M</i>	<i>J</i>	<i>L</i>
0	0.0600	0.114	0.104	0.032	0.026	0.010	0.048	0.035	½
1	0.0730	0.139	0.129	0.039	0.033	0.010	0.060	0.050	½
2	0.0860	0.164	0.154	0.046	0.038	0.010	0.060	0.050	½
3	0.0990	0.188	0.176	0.052	0.044	0.010	0.072	⅙	½
4	0.1120	0.213	0.201	0.059	0.051	0.015	0.072	⅙	½
5	0.1250	0.238	0.226	0.066	0.058	0.015	0.096	⅜	½
6	0.1380	0.262	0.250	0.073	0.063	0.015	0.096	⅜	⅜
8	0.1640	0.312	0.298	0.087	0.077	0.015	0.111	⅜	¾
10	0.1900	0.361	0.347	0.101	0.091	0.020	0.145	⅝	1
¼	0.2500	0.437	0.419	0.132	0.122	0.031	0.183	⅝	1
⅜	0.3125	0.547	0.527	0.166	0.152	0.031	0.216	⅝	1
⅝	0.3750	0.656	0.636	0.199	0.185	0.031	0.251	⅝	1¼
½	0.5000	0.875	0.851	0.265	0.245	0.046	0.372	⅝	2
⅝	0.6250	1.000	0.970	0.331	0.311	0.062	0.454	⅝	2

^a Socket dimensions are given in Table 11.

All dimensions in inches.

These cap screws have been designed and recommended for light fastening applications. They are not suggested for use in critical high-strength applications where socket head cap screws should normally be used.

Standard length increments for socket button head cap screws are as follows: ⅙ inch for nominal screw lengths of ⅙ through ¼ inch, ⅝ inch for nominal screw lengths of ¼ through 1 inch, and ¼ inch for nominal screw lengths of 1 inch through 2 inches. Tolerances on lengths are -0.03 inch for lengths up to 1 inch inclusive. For lengths from 1 through 2 inches, inclusive, length tolerances are -0.04 inch.

The thread conforms to the Unified standard, Class 3A, with radius root, UNRC and UNRF.

To prevent interference, American National Standard ANSI/ASME B18.3.4M-1986 gives metric dimensional and general requirements for a lower head profile hexagon socket button head cap screw. Because of its design, wrenchability and other design factors are reduced; therefore, B18.3.4M should be reviewed carefully. Available only in metric sizes and with metric threads.

For manufacturing details, including materials, not shown, see American National Standard ANSI/ASME B18.3-1998

Table 8. American National Standard Hexagon Socket Head Shoulder Screws
ANSI/ASME B18.3-1998

THIS DIAM. NOT TO EXCEED MAJOR DIAM. OF THREAD

Nominal Size	Shoulder Diameter		Head Diameter		Head Height		Head Side Height	Nominal Thread Size	Thread Length
	Max.	Min.	Max.	Min.	Max.	Min.	Min.		
	D		A		H		S	D ₁	E
1/4	0.2480	0.2460	0.375	0.357	0.188	0.177	0.157	10-24	0.375
5/16	0.3105	0.3085	0.438	0.419	0.219	0.209	0.183	1/4-20	0.438
3/8	0.3730	0.3710	0.562	0.543	0.250	0.240	0.209	3/8-18	0.500
1/2	0.4980	0.4960	0.750	0.729	0.312	0.302	0.262	7/8-16	0.625
5/8	0.6230	0.6210	0.875	0.853	0.375	0.365	0.315	1/2-13	0.750
3/4	0.7480	0.7460	1.000	0.977	0.500	0.490	0.421	5/8-11	0.875
1	0.9980	0.9960	1.312	1.287	0.625	0.610	0.527	3/4-10	1.000
1 1/4	1.2480	1.2460	1.750	1.723	0.750	0.735	0.633	7/8-9	1.125
1 1/2	1.4980	1.4960	2.125	2.095	1.000	0.980	0.842	1 1/8-7	1.500
1 3/4	1.7480	1.7460	2.375	2.345	1.125	1.105	0.948	1 1/4-7	1.750
2	1.9980	1.9960	2.750	2.720	1.250	1.230	1.054	1 1/2-6	2.000

Nominal Size	Thread Neck Diameter		Thread Neck Width	Shoulder Neck Diam.	Shoulder Neck Width	Thread Neck Fillet		Head Fillet Extension Above D	Hexagon Socket Size
	Max.	Min.	Max.	Min.	Max.	Max.	Min.	Max.	Nom.
	G		I	K	F	N		M	J
1/4	0.142	0.133	0.083	0.227	0.093	0.023	0.017	0.014	1/8
5/16	0.193	0.182	0.100	0.289	0.093	0.028	0.022	0.017	5/32
3/8	0.249	0.237	0.111	0.352	0.093	0.031	0.025	0.020	3/16
1/2	0.304	0.291	0.125	0.477	0.093	0.035	0.029	0.026	1/4
5/8	0.414	0.397	0.154	0.602	0.093	0.042	0.036	0.032	5/16
3/4	0.521	0.502	0.182	0.727	0.093	0.051	0.045	0.039	3/8
1	0.638	0.616	0.200	0.977	0.125	0.055	0.049	0.050	1/2
1 1/4	0.750	0.726	0.222	1.227	0.125	0.062	0.056	0.060	5/8
1 1/2	0.964	0.934	0.286	1.478	0.125	0.072	0.066	0.070	7/8
1 3/4	1.089	1.059	0.286	1.728	0.125	0.072	0.066	0.080	1
2	1.307	1.277	0.333	1.978	0.125	0.102	0.096	0.090	1 1/4

All dimensions are in inches. The shoulder is the enlarged, unthreaded portion of the screw. Standard length increments for shoulder screws are: 1/8 inch for nominal screw lengths of 1/4 through 3/4 inch; 1/4 inch for lengths above 3/4 through 5 inches; and 1/2 inch for lengths over 5 inches. The thread conforms to the Unified Standard Class 3A, UNC. Hexagon socket sizes for the respective shoulder screw sizes are the same as for set screws of the same nominal size (see Table 7) except for shoulder screw size 1 inch, socket size is 1/2 inch, for screw size 1 1/2 inches, socket size is 7/8 inch, and for screw size 2 inches, socket size is 1 1/4 inches. For details not shown, including materials, see ANSI/ASME B18.3-1998.

Table 9. American National Standard Slotted Headless Set Screws
ANSI/ASME B18.6.2-1998

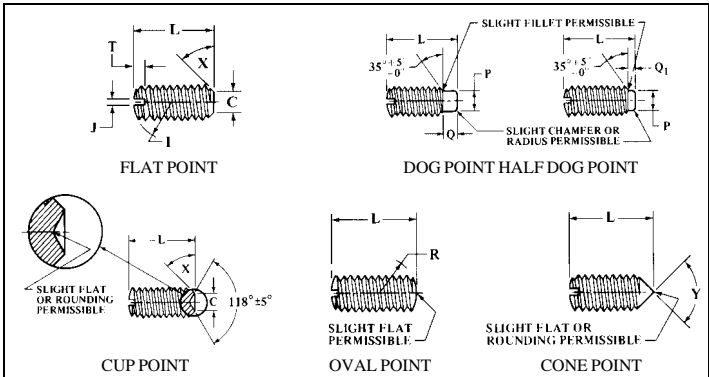

Nominal Size ^a or Basic Screw Diameter	Slot Width, <i>J</i>		Slot Depth, <i>T</i>		Cup and Flat Point Dia., <i>C</i>		Dog Point Dia., <i>P</i>		Point Length			
									Dog, <i>Q</i>		Half Dog, <i>Q1</i>	
	Max.	Min.	Max.	Min.	Max.	Min.	Max.	Min.	Max.	Min.	Max.	Min.
0	0.0600	.014 .010	.020 .016	.033 .027	.040 .037	.032 .028	.017 .013					
1	0.0730	.016 .012	.020 .016	.040 .033	.049 .045	.040 .036	.021 .017					
2	0.0860	.018 .014	.025 .019	.047 .039	.057 .053	.046 .042	.020 .020					
3	0.0990	.020 .016	.028 .022	.054 .045	.066 .062	.052 .048	.027 .023					
4	0.1120	.024 .018	.031 .025	.061 .051	.075 .070	.058 .054	.030 .026					
5	0.1250	.026 .020	.036 .026	.067 .057	.083 .078	.063 .057	.033 .027					
6	0.1380	.028 .022	.040 .030	.074 .064	.092 .087	.073 .067	.038 .032					
8	0.1640	.032 .026	.046 .036	.087 .076	.109 .103	.083 .077	.043 .037					
10	0.1900	.035 .029	.053 .043	.102 .088	.127 .120	.095 .085	.050 .040					
12	0.2160	.042 .035	.061 .051	.115 .101	.144 .137	.115 .105	.060 .050					
¼	0.2500	.049 .041	.068 .058	.132 .118	.156 .149	.130 .120	.068 .058					
⅜	0.3125	.055 .047	.083 .073	.172 .156	.203 .195	.161 .151	.083 .073					
½	0.3750	.068 .060	.099 .089	.212 .194	.250 .241	.193 .183	.099 .089					
⅝	0.4375	.076 .068	.114 .104	.252 .232	.297 .287	.224 .214	.114 .104					
¾	0.5000	.086 .076	.130 .120	.291 .270	.344 .334	.255 .245	.130 .120					
⅞	0.5625	.096 .086	.146 .136	.332 .309	.391 .379	.287 .275	.146 .134					
1	0.6250	.107 .097	.161 .151	.371 .347	.469 .456	.321 .305	.164 .148					
1 ¼	0.7500	.134 .124	.193 .183	.450 .425	.562 .549	.383 .367	.196 .180					

^a When specifying a nominal size in decimals a zero preceding the decimal point or any zero in the fourth decimal place is omitted.

All dimensions are in inches.

Crown Radius, *I*: The crown radius has the same value as the basic screw diameter to three decimal places.

Oval Point Radius, *R*: Values of the oval point radius according to nominal screw size are: For a screw size of 0, a radius of .045; 1, .055; 2, .064; 3, .074; 4, .084; 5, .094; 6, .104; 8, .123; 10, .142; 12, .162; ¼, .188; ⅜, .234; ½, .281; ⅝, .328; ¾, .375; ⅞, .422; 1, .469; and for 1 ¼, .562.

Cone Point Angle, *Y*: The cone point angle is 90° ± 2° for the following nominal lengths, or longer, shown according to screw size: For nominal size 0, a length of ¾; 1, ¾; 2, ¾; 3, ½; 4, ¾; 5, ¾; 6, ¾; 8, ¼; 10, ¼; 12, ¼; ¼, ¼; ⅜, ¼; ½, ¼; ⅝, ¼; ¾, ¼; 1, ¼; 1 ¼, ¼; and for ¾, ¾. For shorter screws, the cone point angle is 118° ± 2°.

Point Angle *X*: The point angle is 45°, + 5°, - 0°, for screws of nominal lengths, or longer, as given just above for cone point angle, and 30°, min. for shorter screws.

Threads: are Unified Standard Class 2A; UNC and UNF Series or UNRC and UNRF Series.

**Table 10. American National Standard Hexagon and Spline Socket Set Screw
Optional Cup Points ANSI/ASME B18.3-1998**

* This diameter may be counterbored.

Nom. Size	Point Dia.		Point Dia.		Point Dia.		Point Length	
	Max.	Min.	Max.	Min.	Max.	Min.	Max.	Min.
	C		C1		C2		S	
0	0.033	0.027	0.032	0.027	0.027	0.022	0.007	0.004
1	0.040	0.033	0.038	0.033	0.035	0.030	0.008	0.005
2	0.047	0.039	0.043	0.038	0.043	0.038	0.010	0.007
3	0.054	0.045	0.050	0.045	0.051	0.046	0.011	0.007
4	0.061	0.051	0.056	0.051	0.059	0.054	0.013	0.008
5	0.067	0.057	0.062	0.056	0.068	0.063	0.014	0.009
6	0.074	0.064	0.069	0.062	0.074	0.068	0.017	0.012
8	0.087	0.076	0.082	0.074	0.090	0.084	0.021	0.016
10	0.102	0.088	0.095	0.086	0.101	0.095	0.024	0.019
¼	0.132	0.118	0.125	0.114	0.156	0.150	0.027	0.022
⅜	0.172	0.156	0.156	0.144	0.190	0.185	0.038	0.033
½	0.212	0.194	0.187	0.174	0.241	0.236	0.041	0.036
⅝	0.252	0.232	0.218	0.204	0.286	0.281	0.047	0.042
¾	0.291	0.270	0.250	0.235	0.333	0.328	0.054	0.049
⅞	0.371	0.347	0.312	0.295	0.425	0.420	0.067	0.062
1	0.450	0.425	0.375	0.357	0.523	0.518	0.081	0.076
1 ⅛	0.530	0.502	0.437	0.418
1 ¼	0.609	0.579	0.500	0.480
1 ⅝	0.689	0.655	0.562	0.542
1 ¾	0.767	0.733	0.625	0.605
1 ⅞	0.848	0.808	0.687	0.667
1 ½	0.926	0.886	0.750	0.730
1 ¾	1.086	1.039	0.875	0.855
2	1.244	1.193	1.000	0.980

All dimensions are in inches.

The cup point types shown are those available from various manufacturers.

Table 11. American National Standard Hexagon and Spline Sockets
ANSI/ASME B18.3-1998

											
BROACHED SOCKET											
HEXAGON SOCKETS											
Nominal Socket Size	Socket Width Across Flats		Nominal Socket Size	Socket Width Across Flats		Nominal Socket Size	Socket Width Across Flats		Nominal Socket Size	Socket Width Across Flats	
	Max.	Min.		Max.	Min.		Max.	Min.		Max.	Min.
	<i>J</i>			<i>J</i>			<i>J</i>			<i>J</i>	
0.028	0.0285	0.0280	$\frac{5}{64}$	0.1426	0.1406	$\frac{7}{16}$	0.4420	0.4375	$1\frac{1}{4}$	1.2750	1.2500
0.035	0.0355	0.0350	$\frac{3}{32}$	0.1587	0.1562	$\frac{1}{2}$	0.5050	0.5000	$1\frac{1}{2}$	1.5300	1.5000
0.050	0.0510	0.0500	$\frac{3}{16}$	0.1900	0.1875	$\frac{5}{16}$	0.5680	0.5625	$1\frac{3}{4}$	1.7850	1.7500
$\frac{1}{16}$	0.0635	0.0625	$\frac{3}{32}$	0.2217	0.2187	$\frac{3}{8}$	0.6310	0.6250	2	2.0400	2.0000
$\frac{3}{64}$	0.0791	0.0781	$\frac{1}{4}$	0.2530	0.2500	$\frac{3}{4}$	0.7570	0.7500	$2\frac{1}{4}$	2.2950	2.2500
$\frac{3}{32}$	0.0952	0.0937	$\frac{5}{16}$	0.3160	0.3125	$\frac{7}{8}$	0.8850	0.8750	$2\frac{3}{4}$	2.8050	2.7500
$\frac{7}{64}$	0.1111	0.1094	$\frac{3}{8}$	0.3790	0.3750	1	1.0200	1.0000	3	3.0600	3.0000
$\frac{1}{8}$	0.1270	0.1250

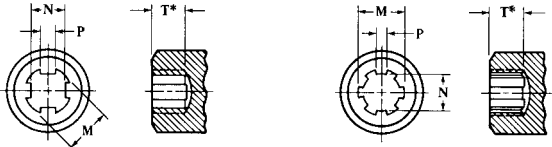
											
SPLINE SOCKETS											
Nominal Socket Size	Number of Teeth	Socket Major Diameter		Socket Minor Diameter		Width of Tooth					
		Max.	Min.	Max.	Min.	Max.	Min.				
		<i>M</i>		<i>N</i>		<i>P</i>					
0.033	4	0.0350	0.0340	0.0260	0.0255	0.0120	0.0115				
0.048	6	0.050	0.049	0.041	0.040	0.011	0.010				
0.060	6	0.062	0.061	0.051	0.050	0.014	0.013				
0.072	6	0.074	0.073	0.064	0.063	0.016	0.015				
0.096	6	0.098	0.097	0.082	0.080	0.022	0.021				
0.111	6	0.115	0.113	0.098	0.096	0.025	0.023				
0.133	6	0.137	0.135	0.118	0.116	0.030	0.028				
0.145	6	0.149	0.147	0.128	0.126	0.032	0.030				
0.168	6	0.173	0.171	0.150	0.147	0.036	0.033				
0.183	6	0.188	0.186	0.163	0.161	0.039	0.037				
0.216	6	0.221	0.219	0.190	0.188	0.050	0.048				
0.251	6	0.256	0.254	0.221	0.219	0.060	0.058				
0.291	6	0.298	0.296	0.254	0.252	0.068	0.066				
0.372	6	0.380	0.377	0.319	0.316	0.092	0.089				
0.454	6	0.463	0.460	0.386	0.383	0.112	0.109				
0.595	6	0.604	0.601	0.509	0.506	0.138	0.134				
0.620	6	0.631	0.627	0.535	0.531	0.149	0.145				
0.698	6	0.709	0.705	0.604	0.600	0.168	0.164				
0.790	6	0.801	0.797	0.685	0.681	0.189	0.185				

All dimensions are in inches.

* Socket depths, *T*, for various screw types are given in the standard but are not shown here.

Where sockets are chamfered, the depth of chamfer shall not exceed 10 per cent of the nominal socket size for sizes up to and including $\frac{1}{16}$ inch for hexagon sockets and 0.060 for spline sockets, and 7.5 per cent for larger sizes.

Table 12. American National Standard Square Head Set Screws
ANSI/ASME B18.6.2-1998

Nominal Size* or Basic Screw Diameter	Cup and Flat Point Diams., C	Dog and Half Dog Point Diams., P		Point Length				Oval Point Rad., R		
		Max.	Min.	Dog, Q		Half Dog, Q1				
				Max.	Min.	Max.	Min.	Max.	Min.	
10	0.1900	.102	.088	.127	.120	.095	.085	.050	.040	.142
1/4	0.2500	.132	.118	.156	.149	.130	.120	.068	.058	.188
5/16	0.3125	.172	.156	.203	.195	.161	.151	.083	.073	.234
3/8	0.3750	.212	.194	.250	.241	.193	.183	.099	.089	.281
7/16	0.4375	.252	.232	.297	.287	.224	.214	.114	.104	.328
1/2	0.500	.291	.270	.344	.334	.255	.245	.130	.120	.375
9/16	0.5625	.332	.309	.391	.379	.287	.275	.146	.134	.422
5/8	0.6250	.371	.347	.469	.456	.321	.305	.164	.148	.469
3/4	0.7500	.450	.425	.562	.549	.383	.367	.196	.180	.562
7/8	0.8750	.530	.502	.656	.642	.446	.430	.227	.211	.656
1	1.0000	.609	.579	.750	.734	.510	.490	.260	.240	.750
1 1/8	1.1250	.689	.655	.844	.826	.572	.552	.291	.271	.844
1 1/4	1.2500	.767	.733	.938	.920	.635	.615	.323	.303	.938
1 3/8	1.3750	.848	.808	1.031	1.011	.698	.678	.354	.334	1.031
1 1/2	1.5000	.926	.886	1.125	1.105	.760	.740	.385	.365	1.125

All dimensions are in inches.

*Threads: Threads are Unified Standard Class 2A; UNC, UNF and 8 UN Series or UNRC, UNRF and 8 UNR Series.

Length of Thread: Square head set screws have complete (full form) threads extending over that portion of the screw length which is not affected by the point. For the respective constructions, threads extend into the neck relief, to the conical underside of head, or to within one thread (as measured with a thread ring gage) from the flat underside of the head. Threads through angular or crowned portions of points have fully formed roots with partial crests.

*When specifying a nominal size in decimals, the zero preceding the decimal point is omitted as is any zero in the fourth decimal place.

Table 13. American National Standard Square Head Set Screws
ANSI/ASME B18.6.2-1998

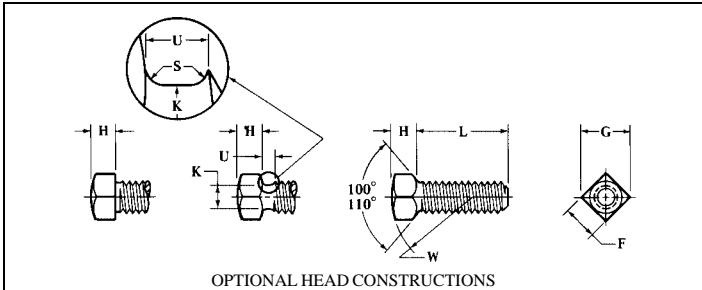

OPTIONAL HEAD CONSTRUCTIONS

Nominal Size or Basic Screw Diameter	Width Across Flats, F		Width Across Corners, G		Head Height, H		Neck Relief Diameter, K		Neck Relief Fillet Rad., S	Neck Relief Width, U	Head Rad., W	
	Max.	Min.	Max.	Min.	Max.	Min.	Max.	Min.	Max.	Min.	Min.	
10	0.1900	.188	.180	.265	.247	.148	.134	.145	.140	.027	.083	0.48
1/4	0.2500	.250	.241	.354	.331	.196	.178	.185	.170	.032	.100	0.62
5/16	0.3125	.312	.302	.442	.415	.245	.224	.240	.225	.036	.111	0.78
3/8	0.3750	.375	.362	.530	.497	.293	.270	.294	.279	.041	.125	0.94
7/16	0.4375	.438	.423	.619	.581	.341	.315	.345	.330	.046	.143	1.09
1/2	0.5000	.500	.484	.707	.665	.389	.361	.400	.385	.050	.154	1.25
9/16	0.5625	.562	.545	.795	.748	.437	.407	.454	.439	.054	.167	1.41
5/8	0.6250	.625	.606	.884	.833	.485	.452	.507	.492	.059	.182	1.56
3/4	0.7500	.750	.729	1.060	1.001	.582	.544	.620	.605	.065	.200	1.88
7/8	0.8750	.875	.852	1.237	1.170	.678	.635	.731	.716	.072	.222	2.19
1	1.0000	1.000	.974	1.414	1.337	.774	.726	.838	.823	.081	.250	2.50
1 1/8	1.1250	1.125	1.096	1.591	1.505	.870	.817	.939	.914	.092	.283	2.81
1 1/4	1.2500	1.250	1.219	1.768	1.674	.966	.908	1.064	1.039	.092	.283	3.12
1 3/8	1.3750	1.375	1.342	1.945	1.843	1.063	1.000	1.159	1.134	.109	.333	3.44
1 1/2	1.5000	1.500	1.464	2.121	2.010	1.159	1.091	1.284	1.259	.109	.333	3.75

Designation: Square head set screws are designated by the following data in the sequence shown: Nominal size (number, fraction or decimal equivalent); threads per inch; screw length (fraction or decimal equivalent); product name; point style; material; and protective finish, if required. Examples: 1/4 - 20 x 3/4 Square Head Set Screw, Flat Point, Steel, Cadmium Plated. .500 - 13 x 1.25 Square Head Set Screw, Cone Point, Corrosion Resistant Steel.

Cone Point Angle, Y: For the following nominal lengths, or longer, shown according to nominal size, the cone point angle is 90° ± 2°: For size No. 10, 1/4, 5/16, 3/8, 1/2, 5/8, 3/4, 7/8, 1, 1 1/8, 1 1/4, 1 1/2, 1 3/8, 1 3/4; and for 1 1/2, 1 3/4. For shorter screws the cone point angle is 118° ± 2°.

Point Types: Unless otherwise specified, square head set screws are supplied with cup points. Cup points as furnished by some manufacturers may be externally or internally knurled. Where so specified by the purchaser, screws have cone, dog, half-dog, flat or oval points as given on the following page.

Point Angle, X: The point angle is 45°, +5°, -0° for screws of the nominal lengths, or longer, given just above for cone point angle, and 30° min. for shorter lengths.

Table 14. Applicability of Hexagon and Spline Keys and Bits

Nominal Key or Bit Size	Cap Screws 1960 Series	Flat Countersunk Head Cap Screws	Button Head Cap Screws	Shoulder Screws	Set Screws
	Nominal Screw Sizes				
HEXAGON KEYS AND BITS					
0.028	0
0.035	...	0	0	...	1 & 2
0.050	0	1 & 2	1 & 2	...	3 & 4
$\frac{1}{16}$ 0.062	1	3 & 4	3 & 4	...	5 & 6
$\frac{5}{64}$ 0.078	2 & 3	5 & 6	5 & 6	...	8
$\frac{3}{32}$ 0.094	4 & 5	8	8	...	10
$\frac{7}{64}$ 0.109	6
$\frac{1}{8}$ 0.125	...	10	10	$\frac{1}{4}$	$\frac{1}{4}$
$\frac{9}{64}$ 0.141	8
$\frac{5}{32}$ 0.156	10	$\frac{1}{4}$	$\frac{1}{4}$	$\frac{5}{16}$	$\frac{5}{16}$
$\frac{3}{16}$ 0.188	$\frac{1}{4}$	$\frac{5}{16}$	$\frac{5}{16}$	$\frac{3}{8}$	$\frac{3}{8}$
$\frac{7}{32}$ 0.219	...	$\frac{3}{8}$	$\frac{3}{8}$...	$\frac{7}{16}$
$\frac{1}{4}$ 0.250	$\frac{5}{16}$	$\frac{7}{16}$...	$\frac{1}{2}$	$\frac{1}{2}$
$\frac{3}{16}$ 0.312	$\frac{3}{8}$	$\frac{1}{2}$	$\frac{1}{2}$	$\frac{3}{8}$	$\frac{3}{8}$
$\frac{3}{8}$ 0.375	$\frac{7}{16}$ & $\frac{1}{2}$	$\frac{5}{8}$	$\frac{5}{8}$	$\frac{3}{4}$	$\frac{3}{4}$
$\frac{7}{16}$ 0.438
$\frac{1}{2}$ 0.500	$\frac{3}{8}$	$\frac{3}{4}$...	1	$\frac{3}{8}$
$\frac{9}{16}$ 0.562	...	$\frac{7}{8}$	1 & $1\frac{1}{8}$
$\frac{3}{4}$ 0.625	$\frac{3}{4}$	1	...	$1\frac{1}{4}$	$1\frac{1}{4}$ & $1\frac{3}{8}$
$\frac{7}{8}$ 0.750	$\frac{7}{8}$ & 1	$1\frac{1}{8}$	$1\frac{1}{2}$
$\frac{1}{8}$ 0.875	$1\frac{1}{8}$ & $1\frac{1}{4}$	$1\frac{1}{4}$ & $1\frac{3}{8}$...	$1\frac{1}{2}$...
1 1.000	$1\frac{3}{8}$ & $1\frac{1}{2}$	$1\frac{1}{2}$...	$1\frac{3}{4}$	$1\frac{3}{4}$ & 2
$1\frac{1}{4}$ 1.250	$1\frac{3}{4}$	2	...
$1\frac{1}{2}$ 1.500	2
$1\frac{3}{4}$ 1.750	$2\frac{1}{4}$ & $2\frac{1}{2}$
2 2.000	$2\frac{3}{4}$
$2\frac{1}{4}$ 2.250	3 & $3\frac{1}{4}$
$2\frac{3}{4}$ 2.750	$3\frac{1}{2}$ & $3\frac{3}{4}$
3 3.000	4
SPLINE KEYS AND BITS					
0.033	0 & 1
0.048	...	0	0	...	2 & 3
0.060	0	1 & 2	1 & 2	...	4
0.072	1	3 & 4	3 & 4	...	5 & 6
0.096	2 & 3	5 & 6	5 & 6	...	8
0.111	4 & 5	8	8	...	10
0.133	6
0.145	...	10	10	...	$\frac{1}{4}$
0.168	8
0.183	10	$\frac{1}{4}$	$\frac{1}{4}$...	$\frac{5}{16}$
0.216	$\frac{1}{4}$	$\frac{5}{16}$	$\frac{5}{16}$...	$\frac{3}{8}$
0.251	...	$\frac{3}{8}$	$\frac{3}{8}$...	$\frac{7}{16}$
0.291	$\frac{5}{16}$	$\frac{7}{16}$	$\frac{1}{2}$
0.372	$\frac{3}{8}$	$\frac{1}{2}$	$\frac{1}{2}$...	$\frac{5}{8}$
0.454	$\frac{7}{16}$ & $\frac{1}{2}$	$\frac{5}{8}$ & $\frac{3}{4}$	$\frac{3}{4}$...	$\frac{3}{4}$
0.595	$\frac{3}{8}$	$\frac{7}{8}$
0.620	$\frac{3}{4}$
0.698	$\frac{7}{8}$
0.790	1

Source: Appendix to American National Standard ANSI/ASME B18.3-1998.

Table 15. American National Standard Hexagon and Spline Socket Set Screws
ANSI/ASME B18.3-1998

Nominal Size or Basic Screw Diameter	Socket Size		Cup and Flat Point Diameters		Half Dog Point		Oval Point Radius	Min. Key Engagement Depth		Lgth. Limit for Angle	
	Hex.	Spl.	Max.	Min.	Max.	Max.	Basic	Hex.	Spl.		
	Nom.	Nom.									P
	J	M	C								
0	0.0600	0.028	0.033	0.033	0.027	0.040	0.017	0.045	0.050	0.026	0.09
1	0.0730	0.035	0.033	0.040	0.033	0.049	0.021	0.055	0.060	0.035	0.09
2	0.0860	0.035	0.048	0.047	0.039	0.057	0.024	0.064	0.060	0.040	0.13
3	0.0990	0.050	0.048	0.054	0.045	0.066	0.027	0.074	0.070	0.040	0.13
4	0.1120	0.050	0.060	0.061	0.051	0.075	0.030	0.084	0.070	0.045	0.19
5	0.1250	1/16	0.072	0.067	0.057	0.083	0.033	0.094	0.080	0.055	0.19
6	0.1380	1/16	0.072	0.074	0.064	0.092	0.038	0.104	0.080	0.055	0.19
8	0.1640	3/64	0.096	0.087	0.076	0.109	0.043	0.123	0.090	0.080	0.25
10	0.1900	3/32	0.111	0.102	0.088	0.127	0.049	0.142	0.100	0.080	0.25
1/4	0.2500	1/8	0.145	0.132	0.118	0.156	0.067	0.188	0.125	0.125	0.31
3/16	0.3125	3/32	0.183	0.172	0.156	0.203	0.082	0.234	0.156	0.156	0.38
3/8	0.3750	3/16	0.216	0.212	0.194	0.250	0.099	0.281	0.188	0.188	0.44
7/16	0.4375	3/16	0.251	0.252	0.232	0.297	0.114	0.328	0.219	0.219	0.50
1/2	0.5000	1/4	0.291	0.291	0.270	0.344	0.130	0.375	0.250	0.250	0.57
5/8	0.6250	3/16	0.372	0.371	0.347	0.469	0.164	0.469	0.312	0.312	0.75
3/4	0.7500	3/8	0.454	0.450	0.425	0.562	0.196	0.562	0.375	0.375	0.88
7/8	0.8750	1/2	0.595	0.530	0.502	0.656	0.227	0.656	0.500	0.500	1.00
1	1.0000	9/16	...	0.609	0.579	0.750	0.260	0.750	0.562	...	1.13
1 1/8	1.1250	9/16	...	0.689	0.655	0.844	0.291	0.844	0.562	...	1.25
1 1/4	1.2500	5/8	...	0.767	0.733	0.938	0.323	0.938	0.625	...	1.50
1 3/8	1.3750	5/8	...	0.848	0.808	1.031	0.354	1.031	0.625	...	1.63
1 1/2	1.5000	3/4	...	0.926	0.886	1.125	0.385	1.125	0.750	...	1.75
1 3/4	1.7500	1	...	1.086	1.039	1.312	0.448	1.321	1.000	...	2.00
2	2.0000	1	...	1.244	1.193	1.500	0.510	1.500	1.000	...	2.25

^a Reference should be made to the Standard for shortest optimum nominal lengths to which the minimum key engagement depths T_H and T_S apply.

^b Cone point angle Y is 90 degrees plus or minus 2 degrees for these nominal lengths or longer and 118 degrees plus or minus 2 degrees for shorter nominal lengths.

All dimensions are in inches. The thread conforms to the Unified Standard, Class 3A, UNC and UNF series. The socket depth T is included in the Standard and some are shown here. The nominal length L of all socket type set screws is the total or overall length. For nominal screw lengths of 1/16 through 3/16 inch (0 through 3 sizes incl.) the standard length increment is 0.06 inch; for lengths 1/8 through 1 inch the increment is 1/8 inch; for lengths 1 through 2 inches the increment is 1/4 inch; for lengths 2 through 6 inches the increment is 1/2 inch; for lengths 6 inches and longer the increment is 1 inch. Socket dimensions are given in Table 11.

Length Tolerance: The allowable tolerance on length L for all set screws of the socket type is ± 0.01 inch for set screws up to 3/8 inch long; ± 0.02 inch for screws over 3/8 to 2 inches long; ± 0.03 inch for

screws over 2 to 6 inches long and ± 0.06 inch for screws over 6 inches long. Socket dimensions are given in Table 11.

For manufacturing details, including materials, not shown, see American National Standard ANSI/ASME B18.3-1998.

British Standard Hexagon Socket Screws — Metric Series.—The first five parts of British Standard BS 4168: 1981 provide specifications for hexagon socket head cap screws and hexagon socket set screws.

Hexagon Socket Head Cap Screws: The dimensional data in Table 1 are based upon BS 4168: Part 1: 1981. These screws are available in stainless steel and alloy steel, the latter having class 12.9 properties as specified in BS 6104:Part 1. When ordering these screws, the designation "Hexagon socket head cap screw BS 4168 M5 \times 20-12.9" would mean, as an example, a cap screw having a thread size of $d = M5$, nominal length $l = 20$ mm, and property class 12.9. Alloy steel cap screws are furnished with a black oxide finish (thermal or chemical); stainless steel cap screws with a plain finish. Combinations of thread size, nominal length, and length of thread are shown in Table 2; the screw threads in these combinations are in the ISO metric coarse pitch series specified in BS 3643 with tolerances in the 5g6g class. (See Metric Screw Threads in Index.)

Hexagon Socket Set Screws: Part 2 of B.S. 4168:1981 specifies requirements for hexagon socket set screws with fiat point having ISO metric threads, and diameters from 1.6 mm up to and including 24 mm. The dimensions of these set screws along with those of cone-point, dog-point, and cup-point set screws in accord, respectively, with Parts 3, 4, and 5 of the Standard are given in Table 3 and the accompanying illustration. All of these set screws are available in either steel processed to mechanical properties class 45H B.S. 6104:Part 3; or stainless steel processed to mechanical properties described in B.S. 6105. Steel set screws are furnished with black oxide (thermal or chemical) finish; stainless steel set screws are furnished plain. The tolerances applied to the threads of these set screws are for ISO product grade A, based on ISO 4759/1-1978 "Tolerances for fasteners — Part 1: Bolts, screws, and nuts with thread diameters greater than or equal to 1.6 mm and less than or equal to 150 mm and product grades A, B, and C."

Hexagon socket set screws are designated by the type, the thread size, nominal length, and property class. As an example, for a flat-point set screw of thread size $d = M6$, nominal length $l = 12$ mm, and property class 45H:

Hexagon socket set screw flat point BS 4168 M6 \times 12-45H

British Standard Hexagon Socket Countersunk and Button Head Screws — Metric Series: British Standard BS 4168:1967 provides a metric series of hexagon socket countersunk and button head screws. The dimensions of these screws are given in Table 4. The revision of this Standard will constitute Parts 6 and 8 of BS 4168.

British Standards for Mechanical Properties of Fasteners: B.S. 6104: Part 1:1981 specifies mechanical properties for bolts, screws, and studs with nominal diameters up to and including 39 mm of any triangular ISO thread and made of carbon or alloy steel. It does not apply to set screws and similar threaded fasteners. Part 2 of this Standard specifies the mechanical properties of set screws and similar fasteners, not under tensile stress, in the range from M1.6 up to and including M39 and made of carbon or alloy steel.

B.S. 6105:1981 provides specifications for bolts, screws, studs, and nuts made from austenitic, ferritic, and martensitic grades of corrosion-resistant steels. This Standard applies only to fastener components after completion of manufacture with nominal diameters from M1.6 up to and including M39. These Standards are not described further here. Copies may be obtained from the British Standards Institution, 2 Park Street, London W1A 2BS and also from the American National Standards Institute, 11 West 42nd Street, New York, N.Y. 10036.

Table 1. British Standard Hexagon Socket Head Cap Screws—Metric Series
BS 4168:Part 1:1981 (obsolescent)

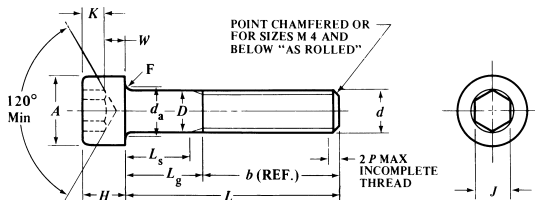

Nominal Size, ^a <i>d</i>	Body Diameter, <i>D</i>		Head Diameter, <i>A</i>			Head Height, <i>H</i>		Hexagon Socket Size, <i>J</i> ^b	Key Engagement, <i>K</i>	Wall Thickness, <i>W</i>	Fillet	
	Max	Min	Max ^c	Max ^d	Min	Max	Min				Rad., <i>F</i>	Diam., <i>d_a</i>
											Min	Max
M1.6	1.6	1.46	3	3.14	2.86	3.14	1.46	1.5	0.7	0.55	0.1	2
M2	2	1.86	3.8	3.98	3.62	2	1.86	1.5	1	0.55	0.1	2.6
M2.5	2.5	2.36	4.5	4.68	4.32	2.5	2.36	2	1.1	0.85	0.1	3.1
M3	3	2.86	5.5	5.68	5.32	3	2.86	2.5	1.3	1.15	0.1	3.6
M4	4	3.82	7	7.22	6.78	4	3.82	3	2	1.4	0.2	4.7
M5	5	4.82	8.5	8.72	8.28	5	4.82	4	2.5	1.9	0.2	5.7
M6	6	5.82	10	10.22	9.78	6	5.70	5	3	2.3	0.25	6.8
M8	8	7.78	13	13.27	12.73	8	7.64	6	4	3.3	0.4	9.2
M10	10	9.78	16	16.27	15.73	10	9.64	8	5	4	0.4	11.2
M12	12	11.73	18	18.27	17.73	12	11.57	10	6	4.8	0.6	14.2
(M14)	14	13.73	21	21.33	20.67	14	13.57	12	7	5.8	0.6	16.2
M16	16	15.73	24	24.33	23.67	16	15.57	14	8	6.8	0.6	18.2
M20	20	19.67	30	30.33	29.67	20	19.48	17	10	8.6	0.8	22.4
M24	24	23.67	36	36.39	35.61	24	23.48	19	12	10.4	0.8	26.4
M30	30	29.67	45	45.39	44.61	30	29.48	22	15.5	13.1	1	33.4
M36	36	35.61	54	54.46	53.54	36	35.38	27	19	15.3	1	39.4

^aThe size shown in () is non-preferred.



^bSee Table 2 for min/max.

^cFor plain heads.

^dFor knurled heads.

All dimensions are given in millimeters.

Table 2. British Standard Hexagon Socket Screws — Metric Series
BS 4168:Part 1:1981 (obsolescent)

Dimensions of Hexagon Sockets					
					
Nominal Socket Size	Socket Width Across Flats, <i>J</i>		Nominal Socket Size	Socket Width Across Flats, <i>J</i>	
	Max.	Min.		Max.	Min.
1.5	1.545	1.52	6	6.095	6.02
2.0	2.045	2.02	8	8.115	8.025
2.5	2.56	2.52	10	10.115	10.025
3	3.08	3.02	12	12.142	12.032
4	4.095	4.02	14	14.142	14.032
5	5.095	5.02	17	17.23	17.05
...	19	19.275	19.065

Association of Nominal and Thread Lengths for Each Thread Size																	
Nominal Length, <i>L</i>	Nominal Thread Size, <i>D</i>								Nominal Length, <i>L</i>	Nominal Thread Size, <i>D</i>							
	M1.6	M2	M2.5	M3	M4	M5	M6	M8		M10	M12	(M14)	M16	M20	M24	M30	M36
2.5									16								
3									20								
4									25								
5									30								
6									35								
8									40								
10									45								
12									50								
16									55								
20									60								
25									65								
30									70								
35									80								
40									90								
45									100								
50									110								
55									120								
60									130								
65									140								
70									150								
80									160								
...									180								
...									200								
<i>b</i> (ref)	15	16	17	18	20	22	24	28	<i>b</i> (ref)	32	36	40	44	52	60	72	84

All dimensions are in millimeters.

The popular lengths are those between the stepped solidlines. Lengths above the dashed lines are threaded to the head within 3 pitch lengths (3*P*). Lengths below the dashed lines have values of *L_g* and *L_s* (see Table 1) given by the formulas: *L_g*max. = *L* nom. - *b* ref., and *L_s*min. = *L_g*max. - 5*P*.

Table 3. British Standard Hexagon Socket Set Screws — Metric Series
BS 4168: Parts 2, 3, 4, and 5: 1994

Nom. Size, d	Pitch, P	Socket Size, s	Depth of Key Engagement, r^a		Range of Popular Lengths				Length of Dog on Dog Point Screws ^b					End Diameters			
					Flat Point	Cone Point	Dog Point	Cup Point	Short Dog, z		Long Dog, z		Flat Point, d_z	Cone Point d_1	Dog Point, d_p	Cup Point, d_c	
					l	l	l	l	min	max	min	max					^b
nom	min	min	l	l	l	l	min	max	min	max	min	max	max	max	max	max	
M1.6	0.35	0.7	0.7	1.5	2-8	2-8	2-8	2-8	0.4	0.65	0.8	1.05	2.5	0.8	0	0.8	0.8
M2	0.4	0.9	0.8	1.7	2-10	2-10	2.5-10	2-10	0.5	0.75	1.0	1.25	3.0	1.0	0	1.0	1.0
M2.5	0.45	1.3	1.2	2.0	2-12	2.5-12	3-12	2-12	0.63	0.88	1.25	1.5	4	1.5	0	1.5	1.2
M3	0.5	1.5	1.2	2.0	2-16	2.5-16	4-16	2.5-16	0.75	1.0	1.5	1.75	5	2.0	0	2.0	1.4
M4	0.7	2.0	1.5	2.5	2.5-20	3-20	5-20	3-20	1.0	1.25	2.0	2.25	6	2.5	0	2.5	2.0
M5	0.8	2.5	2.0	3.0	3-25	4-25	6-25	4-25	1.25	1.5	2.5	2.75	6	3.5	0	3.5	2.5
M6	1.0	3.0	2.0	3.5	4-30	5-30	8-30	5-30	1.5	1.75	3.0	3.25	8	4.0	1.5	4.0	3.0
M8	1.25	4.0	3.0	5.0	5-40	6-40	8-40	6-40	2.0	2.25	4.0	4.3	10	5.5	2.0	5.5	5.0
M10	1.5	5.0	4.0	6.0	6-50	8-50	10-50	8-50	2.5	2.75	5.0	5.3	12	7.0	2.5	7.0	6.0
M12	1.75	6.0	4.8	8.0	8-60	10-60	12-60	10-60	3.0	3.25	6.0	6.3	16	8.5	3.0	8.5	8.0
M16	2.0	8.0	6.4	10.0	10-60	12-60	16-60	12-60	4.0	4.3	8.0	8.36	20	12.0	4.0	12.0	10.0
M20	2.5	10.0	8.0	12.0	12-60	16-60	20-60	16-60	5.0	5.3	10.0	10.36	25	15.0	5.0	15.0	14.0
M24	3.0	12.0	10.0	15.0	16-60	20-60	25-60	20-60	6.0	6.3	12.0	12.43	30	18.0	6.0	18.0	16.0

^aThe smaller of the two l min. values applies to certain short-length set screws. These short-length screws are those whose length is approximately equal to the diameter of the screw. The larger l min. values apply to longer-length screws.

^bA dog point set screw having a nominal length equal to or less than the length shown in the (*) column of the table is supplied with length z shown in the short dog column. For set screws of lengths greater than shown in the (*) column, z for long dogs applies.

All dimensions are in millimeters. For dimensional notation, see diagram, page 1618.

Table 4. British Standard Hexagon Socket Countersunk and Button Head Screws — Metric Series B.S. 4168:1967

COUNTERSUNK HEADSCREWS

Nom. Size ^a	Body Diameter, <i>D</i>		Head Diameter, <i>A</i>		Head Height, <i>H</i>		Hexagon Socket Size, <i>J</i>	Key Engagement, <i>K</i>	Fillet Radius, <i>F</i>
	Max.	Min.	Theor. Sharp Max.	Absolute Min.	Ref.	Flushness Tolerance			
	M3	3.00	2.86	6.72	5.82	1.86			
M4	4.00	3.82	8.96	7.78	2.48	0.20	2.50	1.49	0.40
M5	5.00	4.82	11.20	9.78	3.10	0.20	3.00	1.86	0.40
M6	6.00	5.82	13.44	11.73	3.72	0.20	4.00	2.16	0.60
M8	8.00	7.78	17.92	15.73	4.96	0.24	5.00	2.85	0.70
M10	10.00	9.78	22.40	19.67	6.20	0.30	6.00	3.60	0.80
M12	12.00	11.73	26.88	23.67	7.44	0.36	8.00	4.35	1.10
(M14)	14.00	13.73	30.24	26.67	8.12	0.40	10.00	4.65	1.10
M16	16.00	15.73	33.60	29.67	8.80	0.45	10.00	4.89	1.10
(M18)	18.00	17.73	36.96	32.61	9.48	0.50	12.00	5.25	1.10
M20	20.00	19.67	40.32	35.61	10.16	0.54	12.00	5.45	1.10

^a Sizes shown in parentheses are non-preferred.

BUTTON HEADSCREWS

Nom. Size, <i>D</i>	Head Diameter, <i>A</i>		Head Height, <i>H</i>		Head Side Height, <i>S</i>	Hexagon Socket Size, <i>J</i>	Key Engagement, <i>K</i>	Fillet Radius	
	Max.	Min.	Max.	Min.				<i>F</i>	<i>d_a</i>
	M3	5.50	5.32	1.60				1.40	0.38
M4	7.50	7.28	2.10	1.85	0.38	2.50	1.30	0.20	4.70
M5	9.50	9.28	2.70	2.45	0.50	3.00	1.56	0.20	5.70
M6	10.50	10.23	3.20	2.95	0.80	4.00	2.08	0.25	6.80
M8	14.00	13.73	4.30	3.95	0.80	5.00	2.60	0.40	9.20
M10	18.00	17.73	5.30	4.95	0.80	6.00	3.12	0.40	11.20
M12	21.00	20.67	6.40	5.90	0.80	8.00	4.16	0.60	14.20

All dimensions are given in millimeters.

British Standard Hexagon Socket Set Screws — Metric Series
BS 4168: Parts 2, 3, 4, and 5:1994

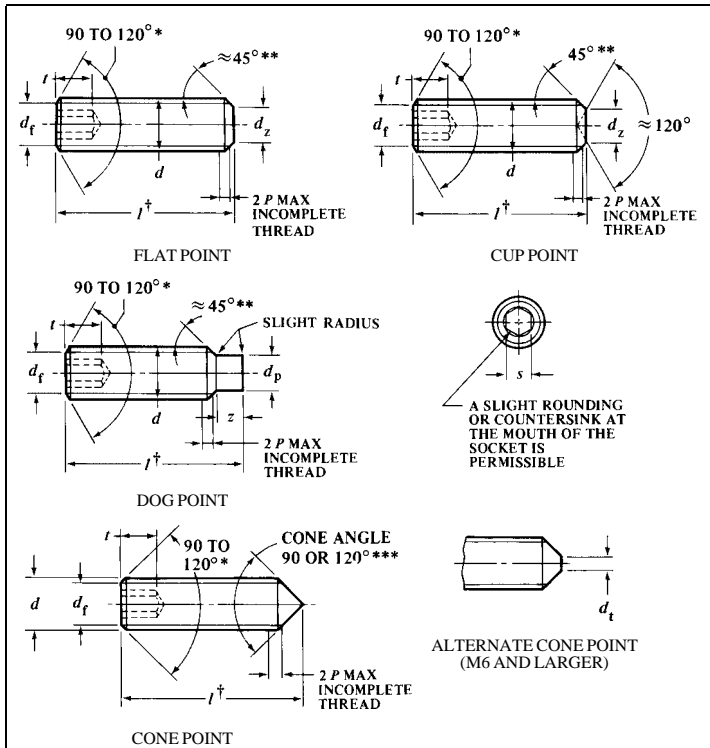

*The 120° angle is mandatory for short-length screws shown in the Standard. Short-length screws are those whose length is, approximately, equal to the diameter of the screw.

**The 45° angle applies only to that portion of the point below the root diameter, d_f , of the thread.

***The cone angle applies only to the portion of the point below the root diameter, d_f , of the thread and shall be 120° for certain short lengths listed in the Standard. All other lengths have a 90° cone angle.

†The popular length ranges of these set screws are listed in Table 3. These lengths have been selected from the following nominal lengths: 2, 2.5, 3, 4, 6, 8, 10, 12, 16, 20, 25, 30, 35, 40, 45, 50, 55, and 60 millimeters.

Holding Power of Set-screws.—While the amount of power a set-screw of given size will transmit without slipping (when used for holding a pulley, gear, or other part from turning relative to a shaft) varies somewhat according to the physical properties of both set-screw and shaft and other variable factors, experiments have shown that the safe holding force in pounds for different diameters of set-screws should be approximately as follows: For $\frac{1}{4}$ -inch diameter set-screws the safe holding force is 100 pounds, for $\frac{3}{8}$ -inch

diameter set-screws the safe holding force is 250 pounds, for 1/2-inch diameter set-screws the safe holding force is 500 pounds, for 3/4-inch diameter set-screws the safe holding force is 1300 pounds, and for 1-inch diameter set-screws the safe holding force is 2500 pounds.

The power or torque that can be safely transmitted by a set-screw may be determined from the formulas, $P = (DNd^{2.3}) \div 50$; or $T = 1250Dd^{2.3}$ in which P is the horsepower transmitted; T is the torque in inch-pounds transmitted; D is the shaft diameter in inches; N is the speed of the shaft in revolutions per minute; and d is the diameter of the set-screw in inches.

Example: How many 1/2-inch diameter set-screws would be required to transmit 3 horsepower at a shaft speed of 1000 rpm if the shaft diameter is 1 inch?

Using the first formula given above, the power transmitted by a single 1/2-inch diameter set-screw is determined: $P = [1 \times 1000 \times (1/2)^{2.3}] \div 50 = 4.1$ hp. Therefore a single 1/2-inch diameter set-screw is sufficient.

Example: In the previous example, how many 3/8-inch diameter set-screws would be required? $P = [1 \times 1000 \times (3/8)^{2.3}] \div 50 = 2.1$ hp. Therefore two 3/8-inch diameter set-screws are required.

Table 5. British Standard Whitworth (BSW) and British Standard Fine (BSF) Bright Square Head Set-Screws (With Flat Chamfered Ends)

Nominal Size and Max. Diam., Inches	Number of Threads per Inch		No. 1 Standard		No. 2 Standard		No. 3 Standard	
			Width Across Flats A	Depth of Head B	Width Across Flats C	Depth of Head D	Width Across Flats E	Depth of Head F
	BSW	BSF						
1/4	20	26	0.250	0.250	0.313	0.250	0.375	0.250
5/16	18	22	0.313	0.313	0.375	0.313	0.438	0.313
3/8	16	20	0.375	0.375	0.438	0.375	0.500	0.375
7/16	14	18	0.438	0.438	0.500	0.438	0.625	0.438
1/2	12	16	0.500	0.500	0.563	0.500	0.750	0.500
5/8	11	14	0.625	0.625	0.750	0.625	0.875	0.625
3/4	10	12	0.750	0.750	0.875	0.750	1.000	0.750
7/8	9	11	0.875	0.875	1.000	0.875	1.125	0.875
1	8	10	1.000	1.000	1.125	1.000	1.250	1.000

* Depth of Head B, D and F same as for Width Across Flats, No. 1 Standard.

Dimensions A, B, C, D, E, and F are in inches.