

BUILD YOUR OWN
METAL WORKING SHOP FROM SCRAP

7

Designing & Building The Sheet Metal Brake

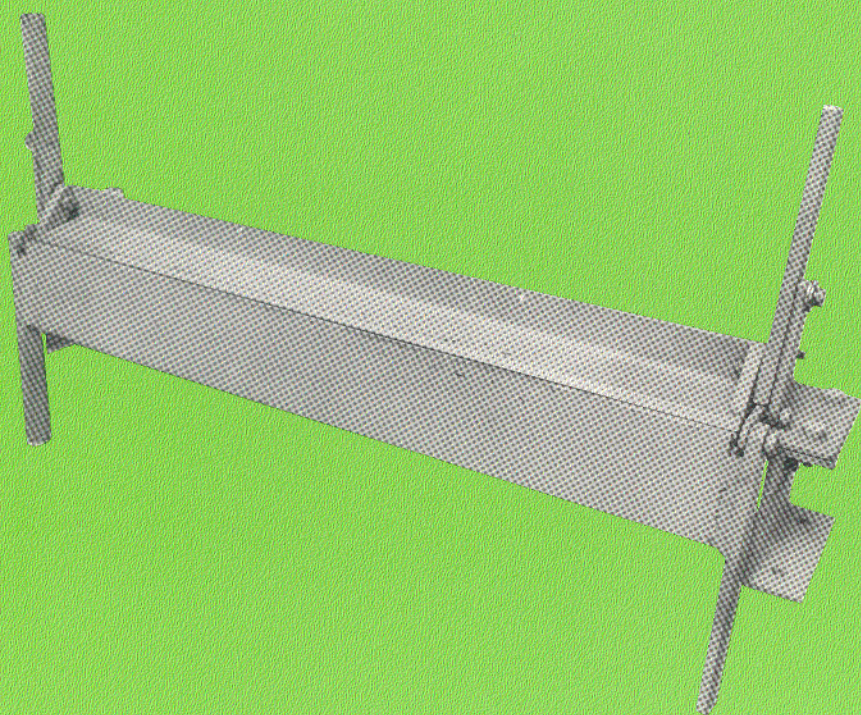

Written and Illustrated by David J. Gingery

**SECOND EDITION
PRINTED 1997**

**First Edition Copyright © 1980
Second Edition Copyright © 1997
DAVID J. GINGERY
All rights reserved**

**LIBRARY OF CONGRESS CATALOG
CARD NUMBER 80-66142**

ISBN-1-878087-06-1

**Published by
DAVID J. GINGERY PUBLISHING
P.O. BOX 75
FORDLAND, MO 65652**

CONTENTS

INDEX TO ILLUSTRATIONS	4
INTRODUCTION	5
Chapter I	
THE ANATOMY AND MECHANICS OF A BRAKE	6
Chapter II	
CONSTRUCTION METHODS	11
Chapter III	
BUILDING THE BED	15
Chapter IV	
ADDING THE BENDING LEAF	24
Chapter V	
ADDING THE CLAMP LEAF	28
Chapter VI	
ADDING THE CLAMP MECHANISM	33
Chapter VII	
HOW TO GET THE MOST OUT OF YOUR BRAKE	41
INDEX	50

INDEX TO ILLUSTRATIONS

Bed complete	23
Bed, end view	20
Bed, rear view	22
Bed, top view	19
Bed with bending leaf	27
Bed with clamp leaf, left end	30
Bed with clamp leaf, rear	31
Bed with clamp leaf, top view	32
Bending leaf & handles	26
Bending leaf pivot point	8
Brake, complete	40
Brake, profile	7
Clamp complete	37
Clamp leaf pivot point	9
Clamp levers	34
Clamp lever pivots	10
Clamp links & lugs	35
Clamp, open	38
Double lap corner seam	45
Duct Lay-out	42
Duct with drive & "S" seam	47 & 48
Duct with "S" slip corner seam	46
Gussets & pivot arms	29
Mounting legs	18
Pittsburg seam	41, 42, 43, 44
Pivot & clamp bracket	17
Plenum	46
Plenum cover	47
Round pipe	48
"S" slips	45
Shoulder bolts	11

INTRODUCTION

The compact bending brake described herein was originally built as an aid to installing duct work for air conditioning and heating jobs. With it, and a couple of sheets of metal I was able to avoid many costly and embarrassing trips back to the shop. The main portion of the job being made up at the shop, it was a simple matter to make up the final fittings right at the job site. The savings in time very materially increased my production capacity.

The illustrated model evolved after several models that were not quite satisfactory. I first tried to do it in a three foot size. While it did the job, it was a lot heavier because of the additional bracing and trusses it required. I found that by reducing the size to 30", I could make it much lighter and more compact. The final product worked so well that I had many requests to sell it to others with the same problem.

As a home shop tool it finds so many uses that, once you have one you'll wonder how you were able to get along without it. So many of my metal shop friends wanted a small brake that I decided to do it up into a manual and include it in the "Metal Shop From Scrap" series.

The 15" size is illustrated because it is convenient for the purpose of showing the necessary details. Also, the size seems to meet the main requirement of the small home shop. If you need a little larger size, simply add to the length of the leaves. All other dimensions will remain the same.

In order to make it a home shop project, the design has been held to simplicity. Capacity and wear adjustments, as found on the commercial big brother, would put the project outside of the scope of the average home shop. It's a fun project that yields a practical piece of equipment at little cost.

CHAPTER I

THE ANATOMY AND MECHANICS OF A BRAKE

It generally comes as a surprise to find how much power is needed to produce a sharp bend in a relatively thin sheet of metal. The longer the work piece, the more serious the problem because it is when you want to bend a longer piece that the sharpness of the bend is really important. It's a simple matter to bend a narrow strap of metal even of fairly heavy gauge. You can do it in a vise or even with a pair of pliers. When you want to make a sheet metal box or a piece of duct, anything that requires a neat sharp bend, you need a brake.

The device described here is a leaf brake. Another type of brake is called a press brake. It uses the mechanical force of a crank shaft or a cam to shape the work between two dies. Still another type uses a roller to force the metal over a die or clamping device. Since it is beyond the scope of most home operations, we'll do no more than mention these exotic breeds as we pass. It is well within the ability of the hobby metal worker to do a good job of building a compact leaf brake of limited size. A look at the material list will show you how very little you need, and the tool requirements are so simple that they will be found in any home shop.

The anatomy of the machine is simple, but it is worth some study before you begin construction. The unit is made up of three separate leaves, the bed leaf, the clamp leaf and the bending leaf. Each leaf is registered in it's proper position by pivot pins. It is the location of these pivot points that is the critical dimension for designing and building an accurate and reliable brake. A look at the drawing on the next page will show you the profile of the brake and identify the main parts and the pivot points.

The mechanics are simple; we clamp the work between the bed leaf and the clamp leaf and raise the bending leaf to the desired angle. Of course, the longer the work piece, the more load there is on the leafs and pivots. Long heavy material needs a long heavy brake.

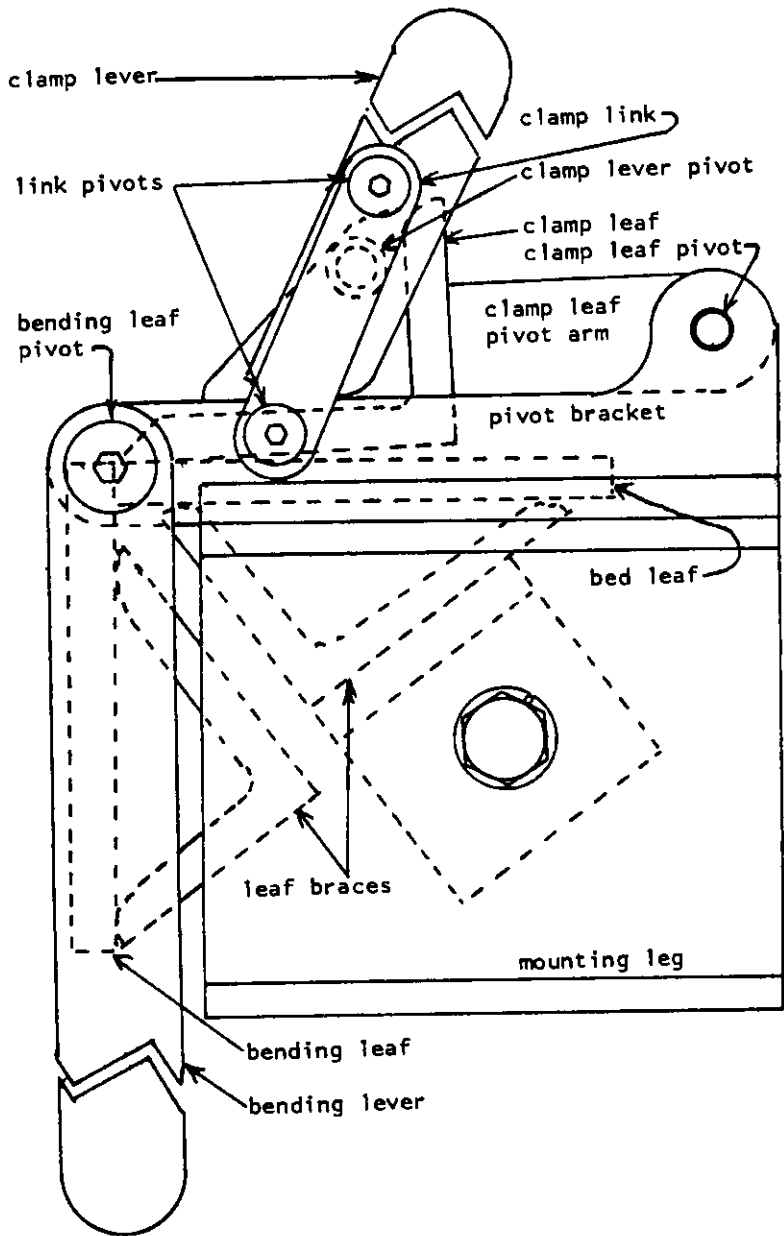

THE BENDING LEAF PIVOT

All three leaves are located in relation to the center of the bending leaf pivot. All of the strain from the force applied to bend the work is concentrated in the bending leaf pivot pins. On a full sized commercial machine, the position of all of the leaves is adjustable in order that a wide range of material thickness can be accommodated, and to provide for take up after wear in the pivot pins. It's not practical to design these adjustments into a home built machine since, like myself, you probably don't have a metal shaper or a milling machine. The care that you use in locating the leaves in respect to the bending leaf pivot center will determine the accuracy of your brake.

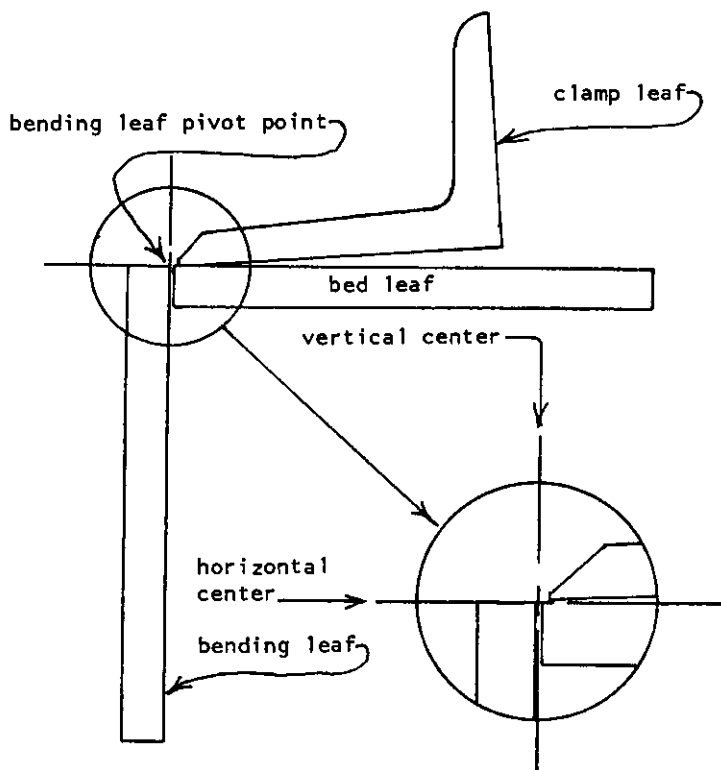

THE CLAMP LEAF PIVOT

The clamp leaf must be raised in order to place the work piece in position for bending. The pivot center is located so that the business edge of the clamp leaf will fall on the bending leaf pivot center, MINUS THE THICKNESS OF THE WORK PIECE. That is; the leading edge of the clamp leaf will be set back from the bending pivot center from $1/32"$ to $1/16"$, depending on the average thickness of the metal you plan to bend. Again, on the commercial brake, this is an adjustable pivot so that the machine will be able to handle a wide range of material. If you build your brake in an 18" width and you plan to bend metal as heavy as 16 gauge, you will want a set back of $1/16"$ or slightly more. It will still handle thinner material, but the bend won't be as sharp. A $1/16"$ set back will be all you need for metal up to 26 gauge.

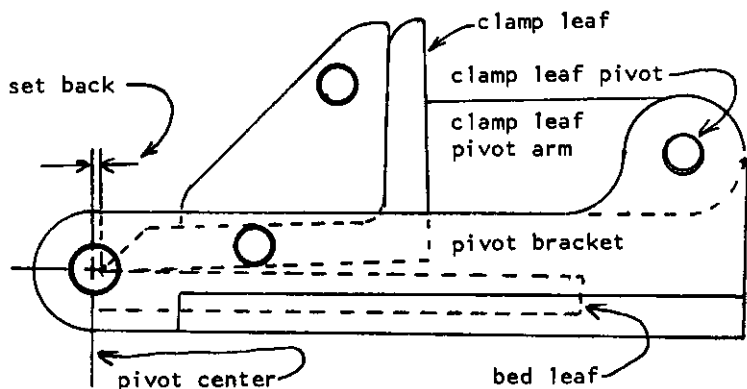

THE CLAMP LEVER PIVOTS

The remaining pivots are in the clamp lever and the link. The mechanical principal is the "over center" clamp. It is also called a "toggle clamp". If you have a pair of "vise grip" pliers, you can study the movement of its action and easily see how it works.

The clamp on our brake uses the same principle. A line drawn through the center of the lower link pivot and the clamp handle pivot will represent the center of the arc of travel for the clamp lever. When the lever carries the upper link pivot over the center the clamp leaf is down snug on the bed. The stop lug prevents any further motion forward so the clamp is locked. Move the lever to the rear and it will become a crank to raise the clamp leaf. Notice that the upper link pivot is located $1/8"$ forward of the clamp lever pivot. This upper point is located during assembly to ensure good clamp action.

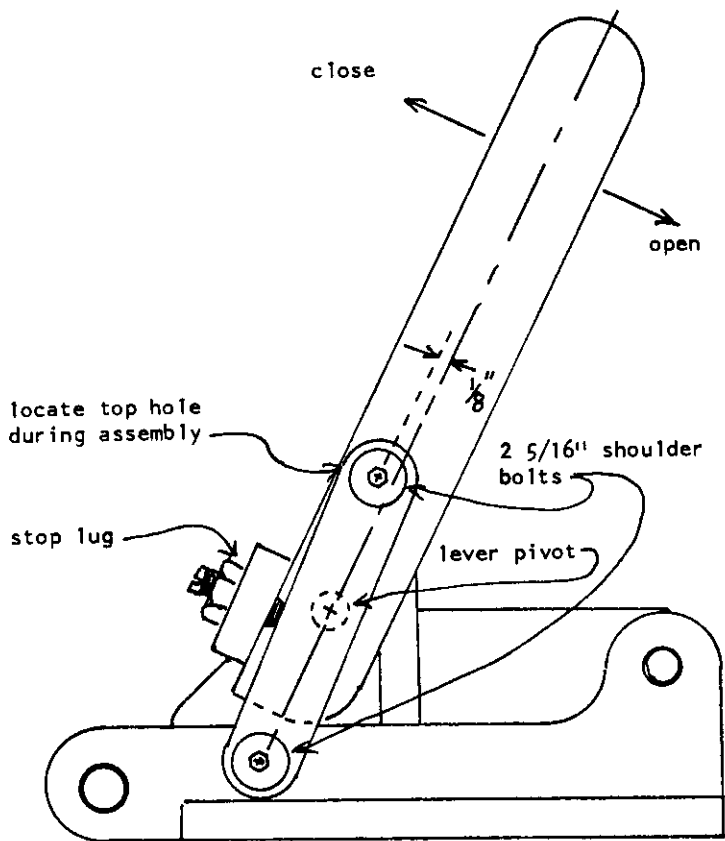

CHAPTER II

CONSTRUCTION METHODS

SELECTING MATERIAL

As the title implies, there is no reason why you can not build your brake from scrap metal. There could be an argument for using cold rolled steel for the bending leaf, but the ordinary class of work does not call for extreme accuracy, and that would be the only reason for using a high grade of material. I've used both cold and hot finished steel, and though the cold rolled presents a sharper edge at the beginning, it's not long before it gets marked up in use. I lean towards the hot rolled material only because it is a lot cheaper to buy.

The 2" x 1-1/2" angle iron was chosen for the clamp leaf because it permitted locating the clamp lever pivot far enough back to allow an overbend. It was used for the leaf braces only because it was on hand. As long as you keep in mind the relationship of the pivot points to each other, you can adapt to material available or what is on hand.

Standard socket head shoulder bolts are suggested for the pivots. Because the shortest standard shoulder length is 3/8", we are obliged to use 3/8" stock for the levers and links. 1/4" stock can be used with washers to take up the slack, but it leaves the action a little too sloppy for my taste.

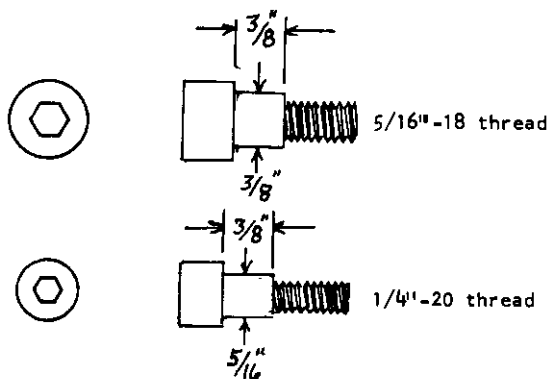

MATERIAL LIST FOR THE 15" BRAKE

- Two- 3" x 1-1/2" channel, 3-1/2" long. (Mounting legs)
- Two- 2" x 1-1/2" angle iron, 4-1/2" long. (Pivot & clamp bracket)
- One*- 1/4" x 3" flat bar, 15-1/4" long. (Bed leaf)
- One*- 2" x 1-1/2" angle iron, 15-1/4" long. (Bed leaf brace)
- Two- 2" x 1-1/2" angle iron, 1-1/2" long. (Bed leaf brace angle)
- Two- 3/8" x 3/4" flat bar, 6-1/2" long. (Bending leaf handle)
- One*- 1/4" x 3" flat bar, 15-3/4" long. (Bending leaf)
- One*- 2" x 1-1/2" angle iron, 15" long. (Bending leaf brace)
- One*- 2" x 1-1/2" angle iron, 15" long. (Clamp leaf)
- One- 3/8" x 3" flat bar, 1-3/8" long. (2 clamp leaf gussets)
- Two- 1/4" x 3/4" flat bar, 1-3/8" long. (Clamp leaf pivot arms)
- Two- 3/8" x 3/4" flat bar, 6" long. (Clamp levers)
- Two- 3/8" x 1/2" flat bar, 3-1/2" long. (Clamp links)
- Two- 1/4" x 3/4" flat bar, 1" long. (Clamp lever stop lugs)
- Two- 3/8" x 3/8" shoulder bolts. (Bending leaf pivots)
- Eight- 5/16" x 3/8" shoulder bolts. (Clamp leaf pivots)
- Four- 5/16" flat washers. (Clamp leaf spacers)
- Eight- 5/16" x 3/4" N.C. cap screws. (Bed ass'y)
- Eight- 5/16" lock washers. (Bed ass'y)
- Two- 5/16" N.C. nuts. (Bed ass'y)

NOTE: The items marked * will vary in length, depending on the size you decide to build.

THE SIZE TO BUILD

The drawings and material list are based on a 15" brake. The same drawings apply to any other size up to 30", except that the length of the leaf parts must be adjusted to the length selected.

While it can be built up to a 36" width, it will be at its extreme capacity with 26 gauge galvanized metal in a full width bend. It can bend heavier stuff in aluminum and in shorter lengths of steel, but a full width in 26 gauge puts a great deal of strain on the pivots and the center of the leaves will yield slightly to produce a curved bend.

With the 30" brake, I have made duct work out of 26 gauge galvanized that measured 60" wide and 24" deep in 30" lengths. While the brake was not capable of cross braking the panels, the relatively short joints of duct, with a standing "S" clip on each joint, made a very rigid installation. The duct was insulated with standard 1" lining and used to deliver ten tons of air conditioning in a church. Since the job was nearly 100 miles from the shop, you can appreciate the savings we enjoyed in not having to make two trips to do the job.

Because its intended use was portable, the brake has evolved to a very compact design. There is no reason why you can't make it larger and heavier. In fact, the original was made of much heavier material throughout. You can increase the length of the pivot brackets to accommodate a wider bed leaf, and you can also increase the length of the levers for a better grip and feel. You can increase the height of the opening capacity if you make the clamp links longer. You will sacrifice some clamping leverage if you do, but you can increase the length of the clamp levers to compensate. If you have access to a machine shop you can beef up the whole design, and even replace the toggle clamp with an eccentric clamp just like the commercial big brother.

Keep in mind that, as you increase the width of the leaves, you add more strain to the pivots, and even the heaviest structural steel will yield in the center if it receives enough force. The commercial machines are large and heavy because they have to be in order to do the job.

THE TOOLS REQUIRED

If you have access to a metal cutting band saw you are in luck, but don't let the lack of power equipment stop you. If you use the best quality high speed blade in a hand hack saw frame you won't find the cutting so bad. Use a 24 tooth blade with a little oil and take your time. A bench grinder or a disc grinder will serve to do the bevel on the clamp leaf and to shape the rounded end of the levers and links.

A drill press would be nice, but a 3/8" electric hand drill will do all of your drilling. Use the step drilling technique and a sharp center punch for accurate hole drilling.

You'll need a 1/4"-20 and a 5/16"-18 tap, and a tap wrench to drive them. A number 7 drill is the right size to use for the 1/4" tap, and a letter size "F" drill for the 5/16" tap. It's worth while to use the exact size drill for tapping, especially in structural steel. Use plenty of cutting oil with the tap, start the tap straight in the hole, and advance in half turns. Back the tap up frequently to clear out the chips. It causes frustration and provokes a man to evil thoughts and bad language to break off a tap when the part is nearly done.

The best fit on the pivot holes would be had with a reamer, but they are costly, and if you don't have them a 5/16" and a 3/8" drill bit will finish the pivot holes.

In addition to the above mentioned, you'll need an arc welder capable of 75 amps or more.

WELDING

Most of the welds will be single pass fillet welds. When you weld the angle iron braces to the leaves start in the center and work towards the ends after the brace is tack welded in position. By "skip" welding, I mean that you should weld 1/2" and skip 3". A 1/2" weld each 3", top and bottom, will be strong enough, and to attempt a weld along the entire length would warp the leaf and make it worthless.

You are ready to start building when you have the material gathered up.

CHAPTER III

BUILDING THE BED

THE MAIN BED PARTS

The bed is the main bulk of the machine, and the bending leaf pivot point is located on the bed. It is the logical place to start, since all other parts are installed with respect to these pivot points.

The bed leaf brace angle, the bed leaf brace and the mounting legs are simple sawing and drilling jobs. The drawings will show you where to cut, drill and tap.

The bed leaf is not fully illustrated because it is no more than a 1/4" x 3" flat. Note that its dimension is 1/4" longer than the nominal size of the brake. Also, in the left end top view, you will see a 1/8" x 3/8" notch. This is for clearance for the end of the pivot pin, and more important, you can cover the pivot hole with a scrap of metal slipped into the slot so you won't spoil the threads when you weld the bed leaf in place.

THE PIVOT AND CLAMP BRACKET

This is the most critical part, and you should use extreme care in locating the pivot holes. The 5/16" tapped hole is the bending leaf pivot hole. The best way is to use tool makers blue dye and a sharp scribe to make an over-sized cross on the center of the hole. It is very difficult to locate the center after drilling, and even worse after tapping. With the sharp crossed lines scribed in the dye, which extend well beyond the hole, you will be able to see the center lines all during construction.

DRILLING AND TAPPING

To avoid moving off the planned center, it is best to "step" drill. That is: begin with a small drill, say 1/8", drill straight through, then change to a larger drill. Changing bits two or three times is a little bit tedious, but attempting to drill the hole with a full sized drill may well ruin the part if it moves off center. Use a sharp center punch, and grip

the part firmly when you drill and tap.

When you tap the holes use plenty of oil, enter the tap straight, and advance it in 1/2 turns. Use a tap wrench, and back up a turn or so, frequently, to clear the hole of chips. If you are not skilled with tapping holes, you might drill and tap a couple of holes in some scrap material just to get the feel of it.

The two holes that are used to bolt the bracket to the leg can be drilled out to tap size with the bracket clamped in position on the leg. You can then separate the parts, tap the holes in the leg, drill the holes in the bracket to 5/16", and the holes will be in perfect register.

The remaining holes are not as critical, but be as careful as you can.

GETTING SET UP TO BUILD

The next four pages will show you how to shape the parts and where to locate the holes. Study the drawings until they are clear to you. Notice that there is a right and left hand pivot and clamp bracket. The holes for the bending leaf pivot are tapped 5/16"-18, and the holes for the clamp leaf pivots and the links are tapped 1/4" -20. Take care to see that your drilling and tapping is done at 90 degrees to the flat surface. The inside of the angle iron is slightly tapered, so when you cut out the notch at the front of the bracket, you'll need to do a little filing or grinding to clean up the side of the bending leaf pivot point. Drill and tap all holes before you do any welding, and protect the threaded holes when you weld the parts together.

The sectional view of the left end through the center will show you exactly how to position the bed leaf, and you will see how helpful and important the sharp and clear cross mark at the bending leaf pivot point will be.

Clamp the work securely for welding, drilling and tapping, and wear protective glasses when you grind.

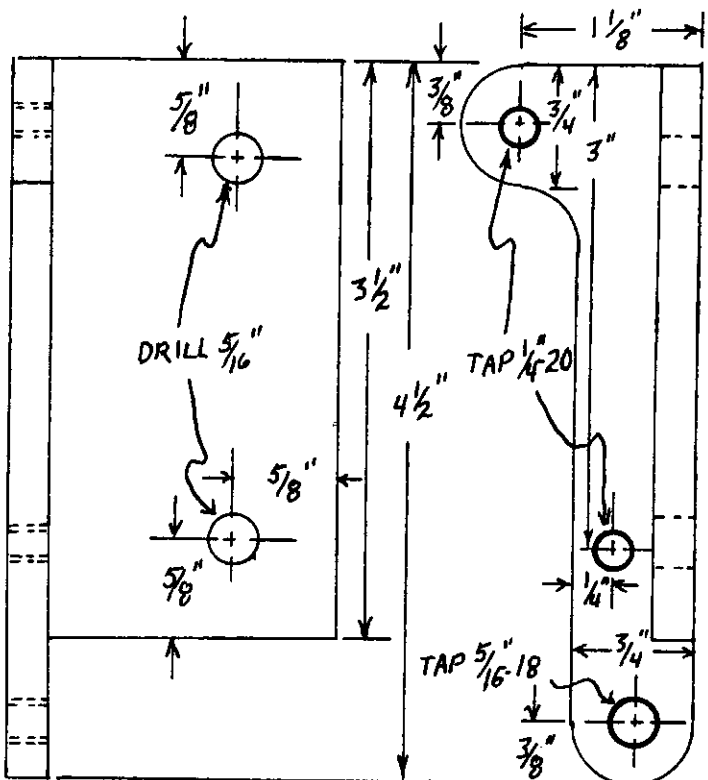

Pivot and clamp bracket-Make 2
 One right hand- One left hand
 2" X 1 1/2" X 1/4" Angle iron

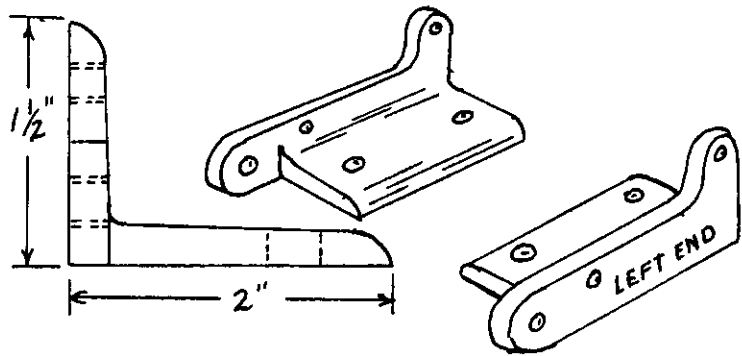

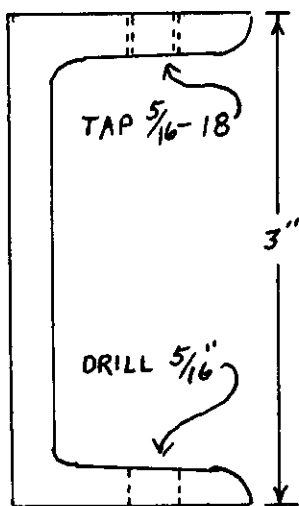
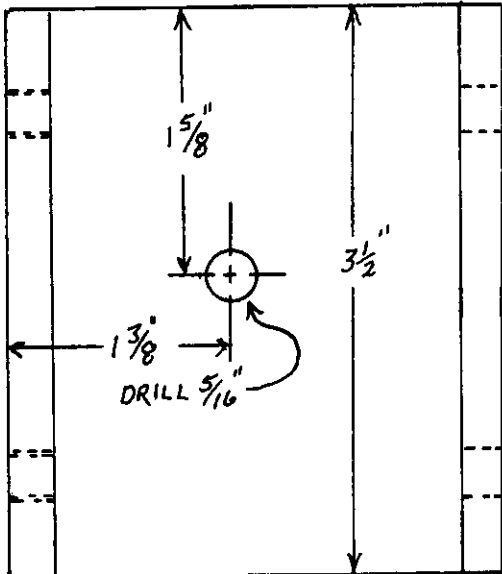
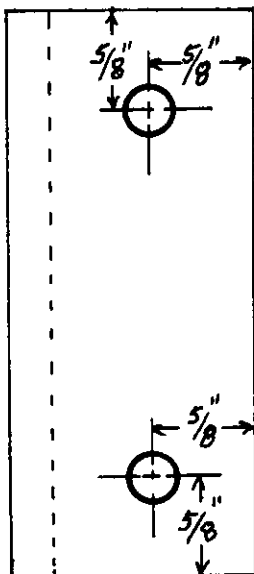

Mounting leg- Make 2
3" X 1 1/2" Channel iron

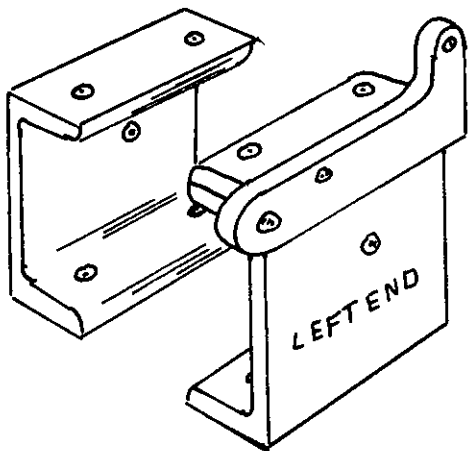

FRONT OF BED LEAF CENTERED ON PIVOT HOLE

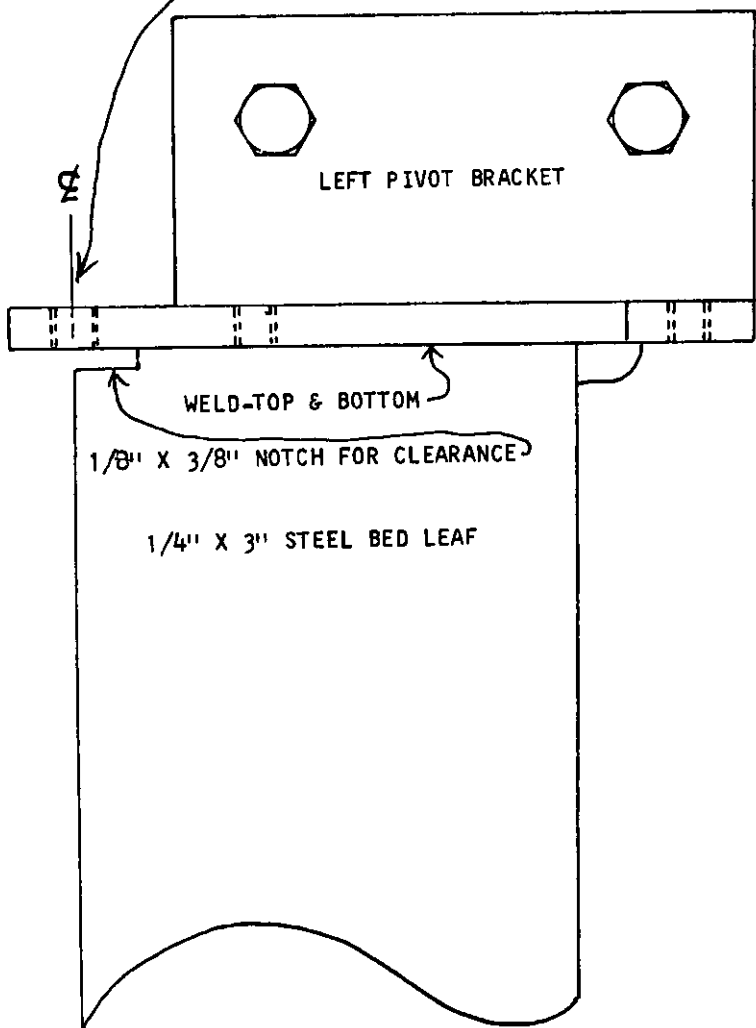

VIEW OF LEFT END FROM TOP

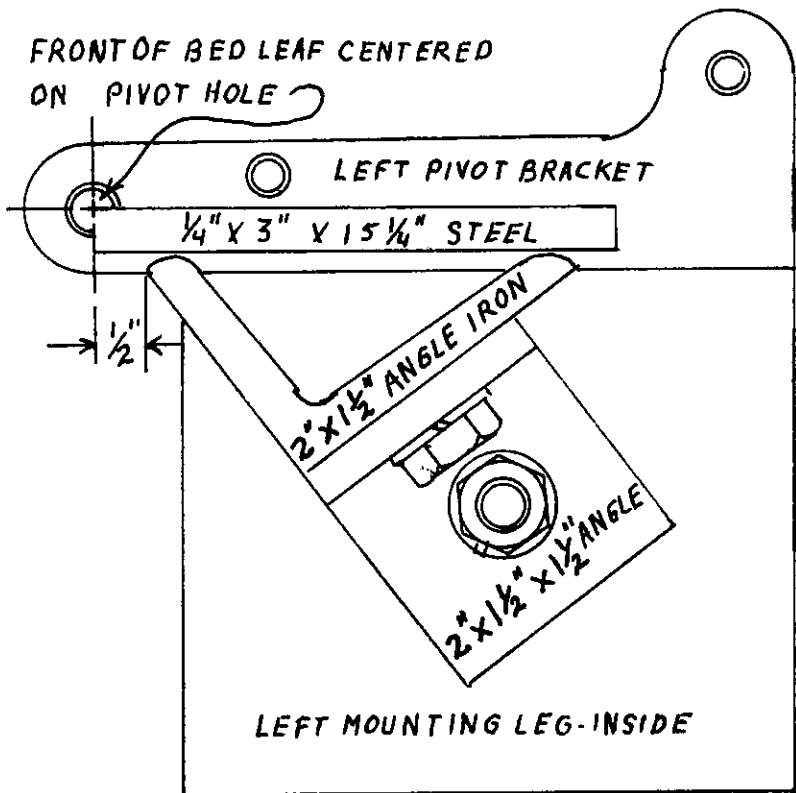

SECTIONAL VIEW OF LEFT END THROUGH CENTER

WELD IN THE BED LEAF

The bed leaf is welded to the pivot bracket before the brace is welded on, and the two short angles are installed last of all. The short angles can be welded or bolted.

The best way to locate the bed leaf is to clamp the brackets to a flat surface. A straight length of 2" x 4" lumber will do. Place a 1/8" spacer on the surface, and clamp the bed leaf over the spacer. You can then check the position to make sure that the top surface of the leaf is in line with the horizontal center line of the bending leaf pivot. Also, see that the front edge of the leaf is on the vertical center line of the pivot. When everything is lined up, cover the tapped holes to protect the threads from weld spatter, and tack weld the leaf to the brackets. Re-check the position and make a single pass fillet weld at each end. It may be necessary to do a little filing or grinding on this weld to ensure clearance for the clamp leaf if you build up too much metal.

After the top weld has cooled, remove the clamps and invert the entire assembly. It is a good idea to clamp a piece of angle iron to both brackets to prevent warping when you weld the bottom of the leaf to the bracket. A single pass fillet weld at each end of the leaf, on the bottom, will be strong enough.

WELD IN THE BED LEAF BRACE

The 2" x 1-1/2" angle iron brace is positioned with 1/2" clearance at the front. Tack weld both ends, front and back, and proceed to skip weld the brace to the bed leaf at 3" intervals. Begin at the center and work towards each end, alternating from front to back as you go. There is no need for a full weld along the length of the bed, and to attempt to do so, would surely warp the bed badly. A 1/2" weld at 3" intervals will give you all the strength you need.

COMPLETE THE BED

The rest is simple. Bolt the mounting legs to the brackets and add the short angle braces at each end. While the drawings show the angle braces bolted to the bed brace and the mounting legs, you can weld them in place if you prefer. Make sure that the mounting legs will rest flat on the bench before you fasten the braces in place permanently.

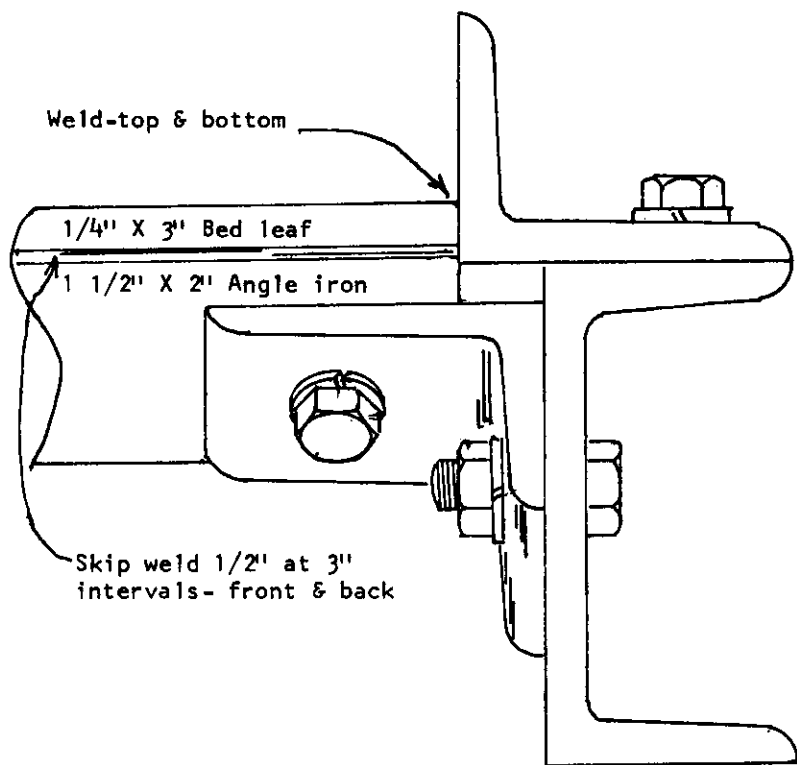

VIEW AT LEFT END FROM REAR

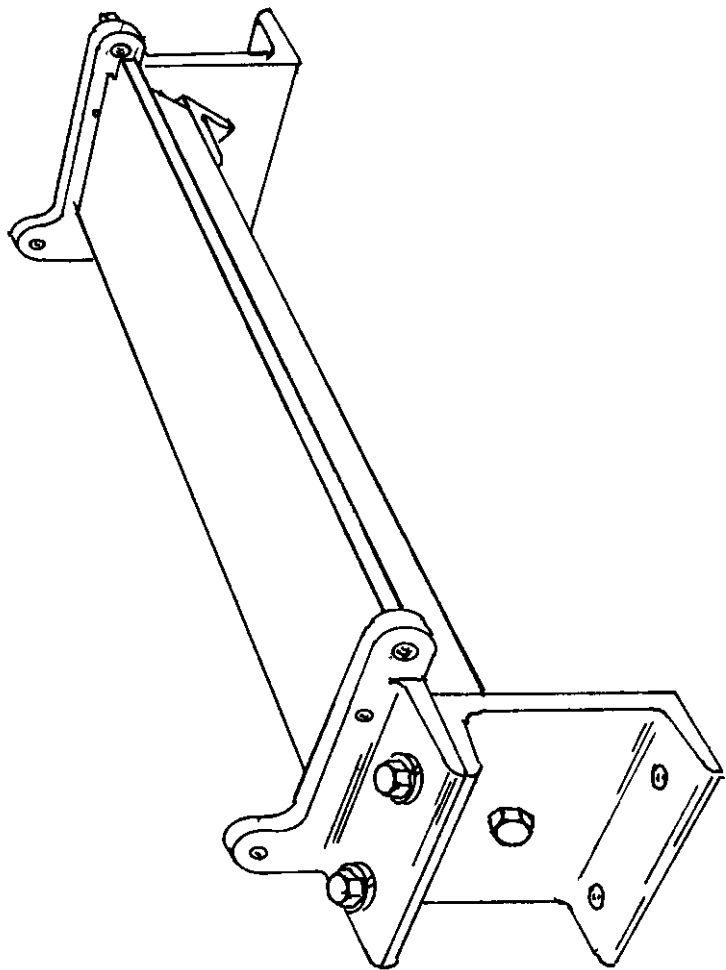

BED COMPLETED- READY TO ADD BENDING LEAF

CHAPTER IV

ADDING THE BENDING LEAF

CHECK YOUR WORK

If you have been careful to position the bed leaf with its top surface on the horizontal center line of the bending leaf pivot, and its front surface on the vertical center line, you will have no trouble in aligning the rest of the brake. A slight error doesn't mean complete failure; in a home shop set up, your capability for precision is understandably limited. An error of as much as 1/16" doesn't mean you have to start all over.

At this point you can bolt the brake to the bench; it won't be necessary to move it again until you paint it, and it will be a help to have it securely mounted.

THE BENDING LEAF HANDLES

Cut the handles from the 3/8" x 3/4" steel. You can cut the corners with the hack saw and finish rounding the ends on the grinder.

Step drill the 3/8" hole in one end of each handle and install the shoulder bolts through the hole with a nut that is as thick as the pivot bracket. Cut off the excess threaded portion so that it will not protrude beyond the thickness of the pivot bracket.

Now, install the handles on the brackets, making sure that they move freely on the pivots. If there is any binding as the handle moves through its swing, now is the time to file or grind as necessary. There should be a slight amount of side play in the pivot when the shoulder bolt is tightened securely.

THE BENDING LEAF

As with the bed leaf, the bending leaf is not fully illustrated. It is a piece of 1/4" x 3" steel flat with a 1/2" x 3/8" notch in each end.

Its length is 1/2" longer than the bed leaf because the pivot brackets are each 1/4" thick. It would be well to measure between the handles before you cut the bending leaf to length.

WELDING THE BENDING LEAF

With the handles installed and hanging down, clamp the bending leaf to the bed leaf with its top surface even with the top surface of the bed leaf.

You should still be able to see the scribed center lines on the pivot bracket. If the bed leaf is behind the center, shim the bending leaf so that its rear top edge is on the pivot center. A small gap between the bed leaf and the bending leaf will do no harm.

If the bending leaf is mounted above center, it will meet interference from the bed and clamp leaf when you try to rotate beyond the 90 degree point. The same problem will occur if the bending leaf is mounted behind the center line. To be outside or slightly below center will only increase the radius of the bend, and does not cause a serious problem.

If your pivot point is above or below center, you can correct it by heating the pivot bracket to a red heat and bending it up or down as needed.

When you have the bending leaf clamped in its proper position, tack weld it to the handles on each end and remove the clamps. Raise the handles to make sure that the leaf will rotate through the entire 135 degrees. If all fits and works smoothly, weld a single pass, front and back, on each end.

THE BENDING LEAF BRACE

The brace is a piece of 2" x 1-1/2" angle iron that is cut 3/4" shorter than the bending leaf so that its ends will clear the mounting feet when the leaf is in the down position.

It is positioned 1/2" below the top edge of the bending leaf. Tack weld it in position and skip weld, from the center out, just as you did the bed leaf brace. It can be welded on with the bending leaf rotated to its full up position. Protect the business edge of both leaves from spatter to avoid a clean up job.

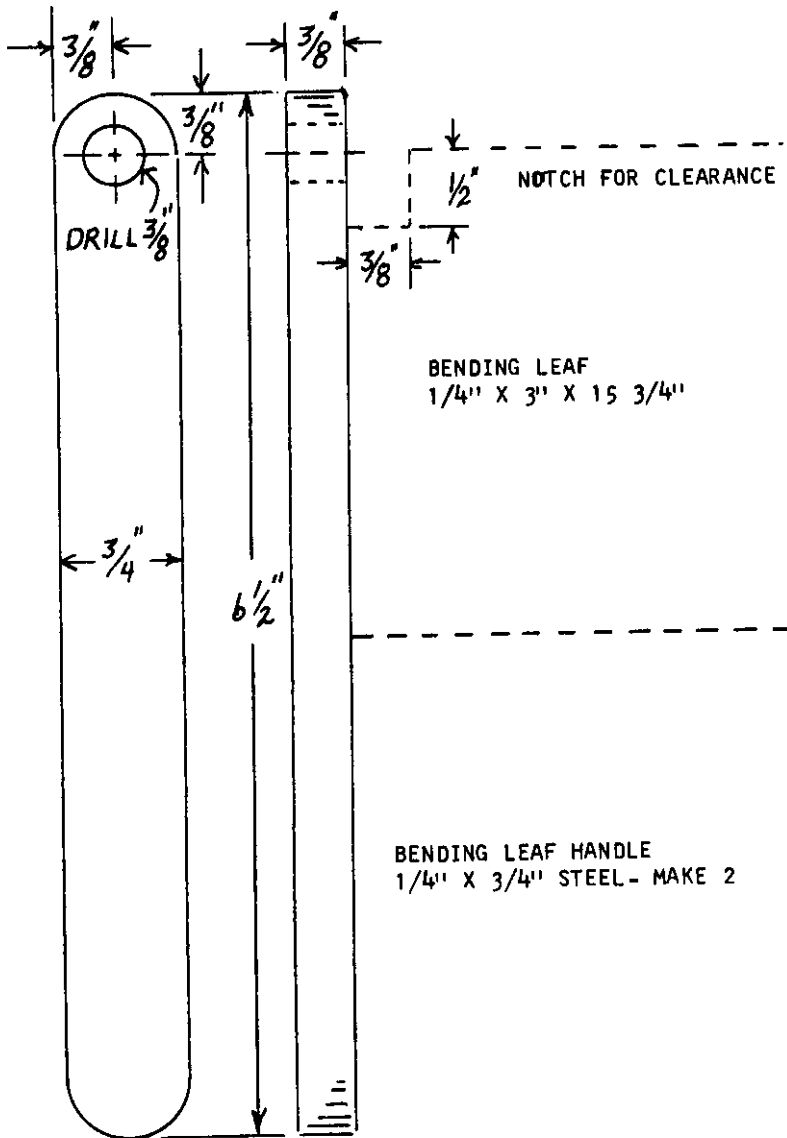

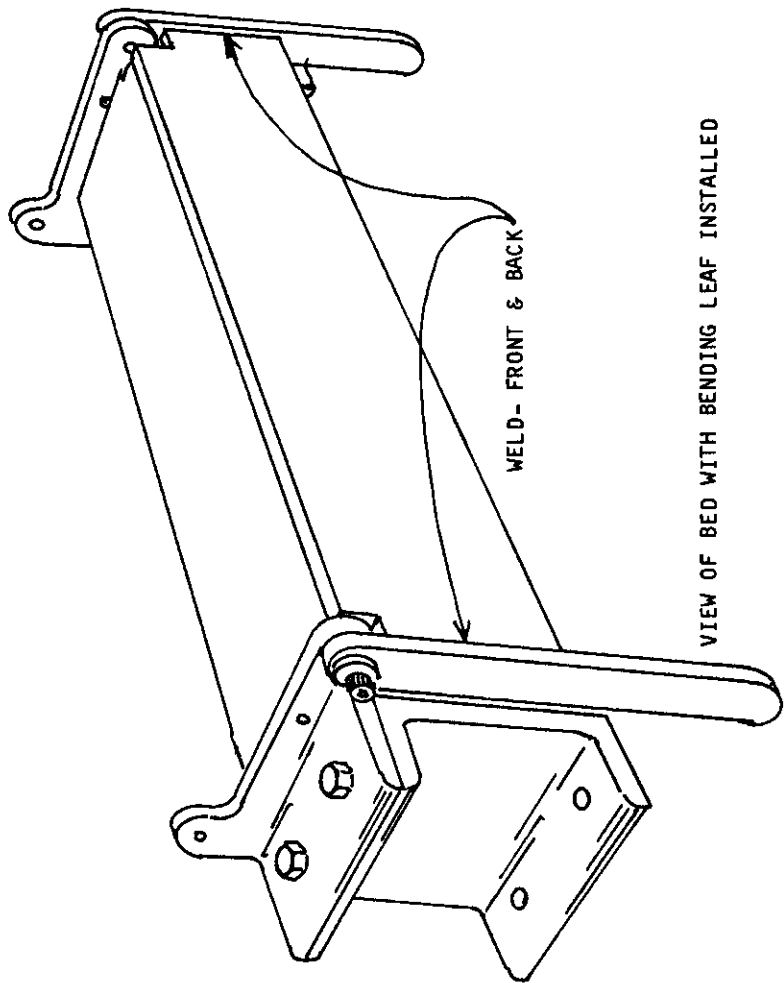

WELD - FRONT & BACK

VIEW OF BED WITH BENDING LEAF INSTALLED

CHAPTER V

THE CLAMP LEAF

SHAPING THE LEAF

The clamp leaf is simply a piece of 2" x 1-1/2" angle iron, cut 1/4" shorter than the distance between the pivot brackets. This provides 1/8" clearance on each end of the leaf for free movement. The bevel on the front of the leaf can be ground with a disc grinder or on the emery wheel. It needs to be done before the leaf is installed on the brake. Most of the work is done for you since the edge of the angle is a radius. You don't want a knife edge, but rather a slightly blunt edge. A sharp edge will be weak and easily damaged. The whole object of the beveled edge is to provide clearance for bending beyond 90 degrees.

THE GUSSETS AND PIVOT ARMS

Notice that the gussets are 3/8" thick, and the pivot arms are 1/4" thick. There will be washers installed between the arms and brackets, but no washers between the gussets and the clamp levers. Shape the parts according to the drawings and step drill the 5/16" holes. Try the shoulder bolts in the holes with a nut to make sure they turn freely. If you have to file or grind a little off the thickness, it's easier now than when the leaf is completed. In any case, you will need to do some filing or grinding to profile the parts. It may be necessary to shorten the length of the arms when you install the leaf.

ASSEMBLE THE PARTS

Center the leaf on the bed so that it has equal clearance on each end, and the beveled edge is about 1/32" back from the pivot center. Place a 1/8" shim under the rear edge of the leaf so that only the front edge contacts the bed leaf. Clamp the leaf securely in place.

Install the pivot arms to the brackets with the shoulder bolts and

washers. It is at this point that you may find it necessary to shorten the arms so that they will fit in the allotted space.

When all is lined up properly, tack weld the arms to the leaf, and at the same time, tack weld the gussets in place. Remove the clamps and the shoulder bolts so that you can position the leaf for easy welding. Weld both the arms and the gussets to the leaf. Keep in mind that the clamp lever will bear on the ends of the leaf. If you do any welding on the outside, you will have to grind it off when you fit the clamp levers.

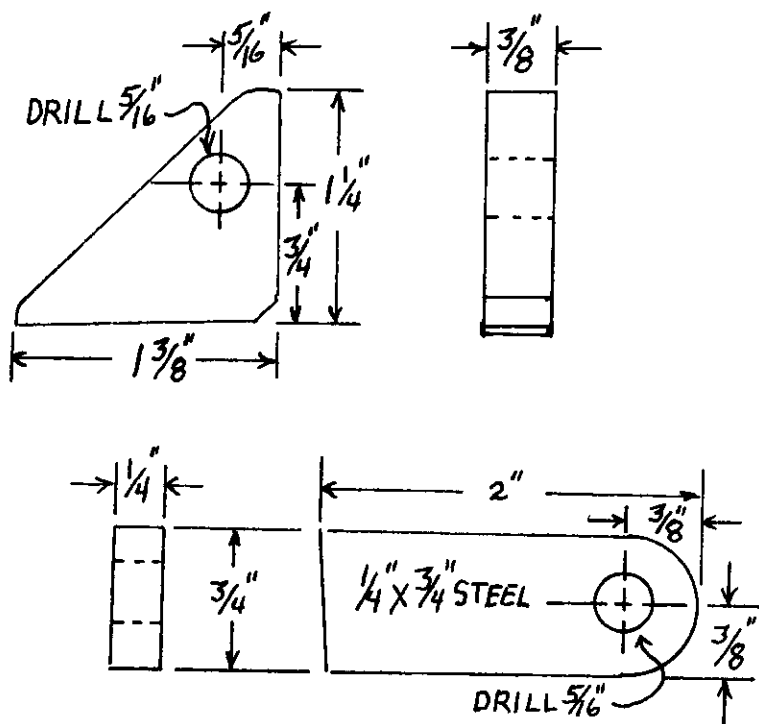

GUSSETS & PIVOT ARMS- MAKE 2 EACH

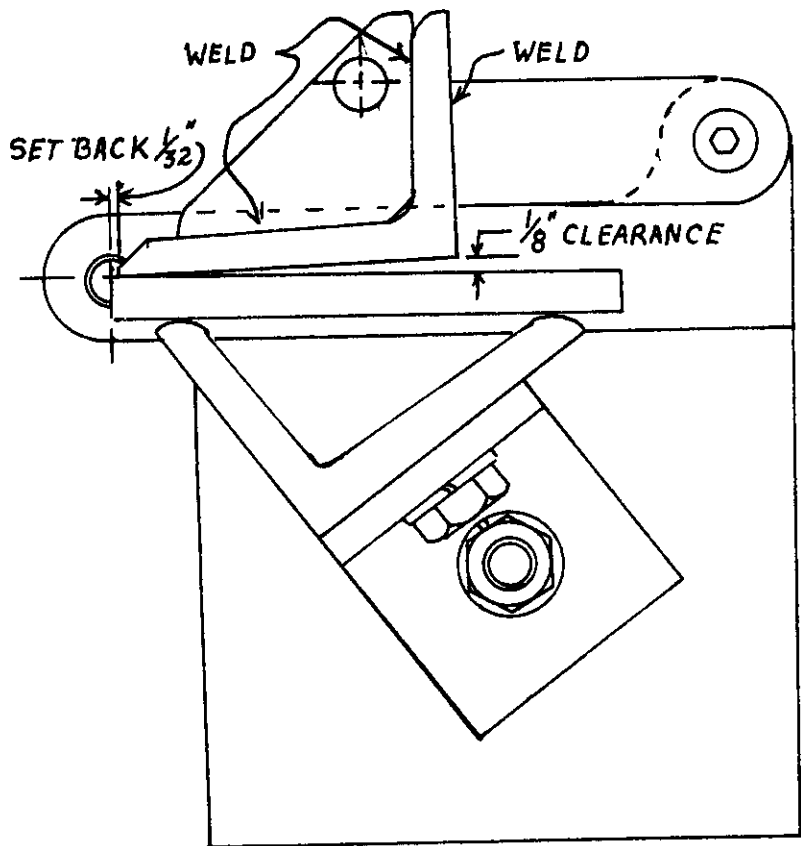

SECTIONAL VIEW OF LEFT END THROUGH CENTER

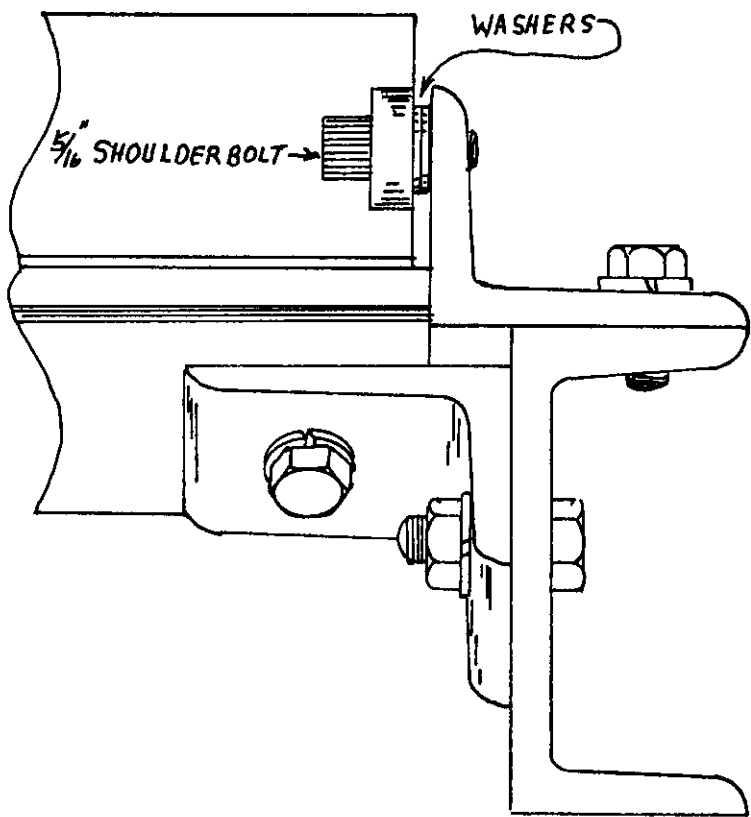

VIEW AT LEFT END FROM REAR

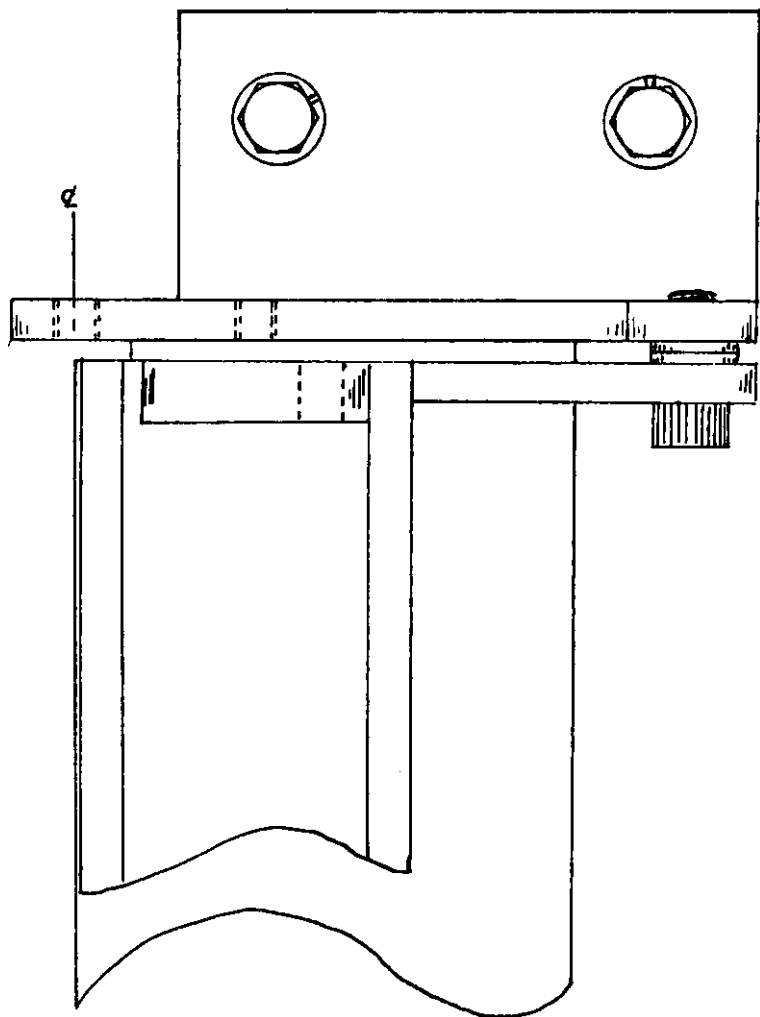

VIEW OF LEFT END FROM TOP

CHAPTER VI

THE CLAMP MECHANISM

THE CLAMP LEVERS

Cut the parts from the stock and form the rounded ends on the grinder. Note that there is a right hand and a left hand lever.

The upper link pivot hole is located during assembly so don't mark or drill it at this time. The lever pivot hole is drilled and tapped for 1/4"-20. Cut the stop lugs to size, drill and tap the adjustment screw hole and clamp the lug to the lever.

The lug can be welded to the lever, but keep in mind that both sides of the lever must be fairly smooth. Unless you are a pretty good welder, the better idea is to fasten the lug to the lever with the flat head machine screws.

Clamp the lug in place, drill one hole tap size, through the lug and into the lever. Remove the lug, drill the hole to 3/16" and countersink. Tap the hole in the lever, and re-assemble with one screw. Repeat the process for the other screw. With this method you won't have any problem with mis-aligned holes.

THE CLAMP LINKS

As mentioned earlier, the length of the links will determine how wide the clamp leaf will open.

The 3-1/2" links will open the clamp a little over 1" so that you can admit a 1" over-bend and squeeze it down to make a hem or pocket.

If you shorten the links to 2-1/2", the clamp will open about 1/2". A 3" link will open about 3/4". Your choice will depend on your main intended use for the brake.

The longer links provide wider opening, but the clamping leverage is much greater with the shorter links.

You can make a pair of each and exchange them if your needs vary. The extra set of holes in the clamp lever will do no harm.

Cut the links to size, step drill the holes to 5/16", and file or grind the lower end to fit the inside corner of the pivot bracket.

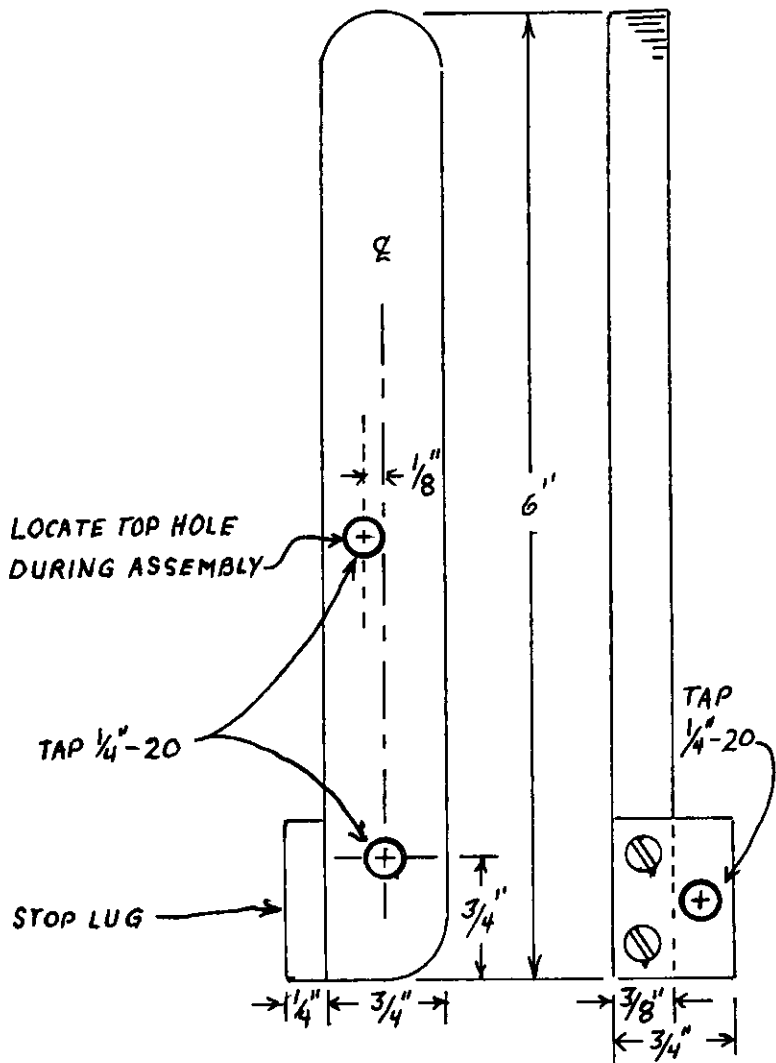

CLAMP LEVERS- MAKE 2- 1 RIGHT- 1 LEFT

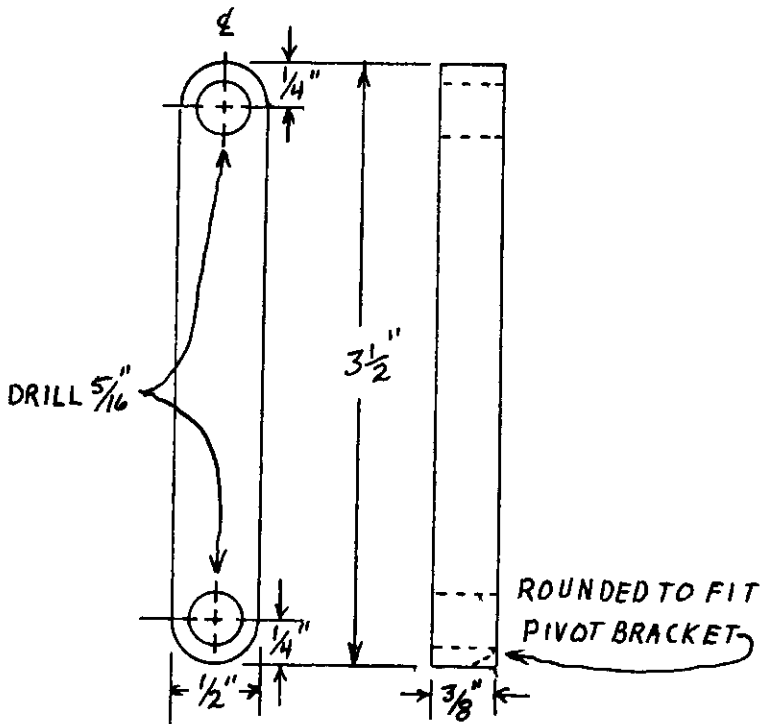

CLAMP LINKS - MAKE 2

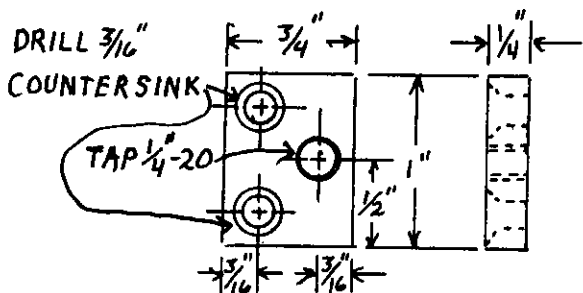

STOP LUGS - MAKE 2

LOCATING THE UPPER LINK PIVOT HOLE

The action of the toggle clamp requires that the upper link pivot must pass over center to lock the clamp. The clamp lever acts as a crank to carry the upper link pivot pin through its arc of travel, and the location of clamp pivots are planned to force the clamp leaf down and forward. When the upper link pivot passes the over center point, the clamp is locked. Any upward or rearward pressure will tend to move the lever forward. The stop lug prevents further motion. The lever must be moved to the rear, over center, to release the clamp.

The clamp leaf was installed with 1/8" clearance at the rear so that only the leading edge of the leaf clamps the work. This feature gives a little bit of spring tension to the action.

It would take some pretty exotic equipment to predict the location of the last pivot point if it weren't for our blue marking dye. Just swab some dye on each lever, and when it dries, scribe a line 1/8" forward of the center. Install the links with the 5/16" shoulder bolts at the lower end and make sure that they swing through their arc of travel without binding. Install the levers to the leaf and make sure that the lower end of the lever does not contact the pivot bracket when the leaf is snug on the bed. With the shoulder bolts tight, and the levers and links able to move freely on their pivots; move the link in position, sighting through the upper link pivot hole until the hole is centered on the scribed line. Scribe the circle inside the hole and you've got it.

Remove the lever; carefully locate the center of the scribed circle, and, center punch about .005" above the center mark. That will be just about the width of the scribed line. Step drill the hole to tap size and tap for 1/4"-20.

The object to moving the pivot center slightly above the center is to provide a little tension to the clamp action. Remember that you have done all of this with no metal in the clamp and the adjustment screws are left out. When you clamp a piece of metal in the brake, the tension will be greater. The process may seem confusing at first, but it's really quite simple.

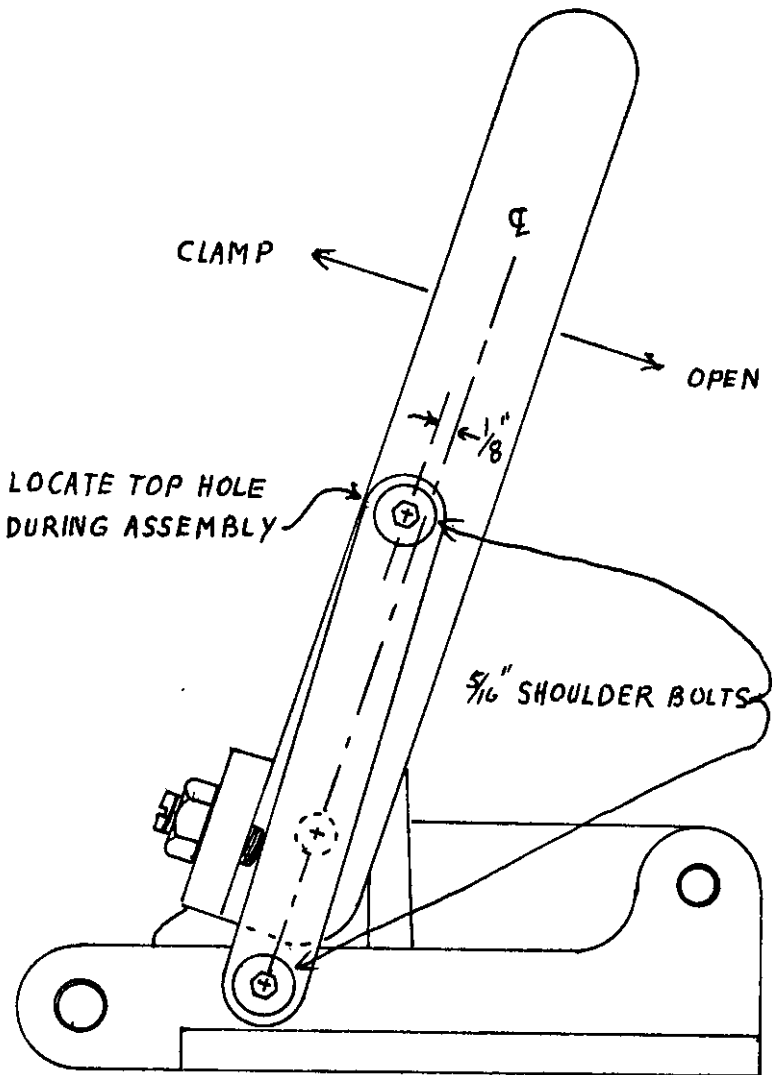

VIEW OF CLAMP LEVER & LINK AT RIGHT END

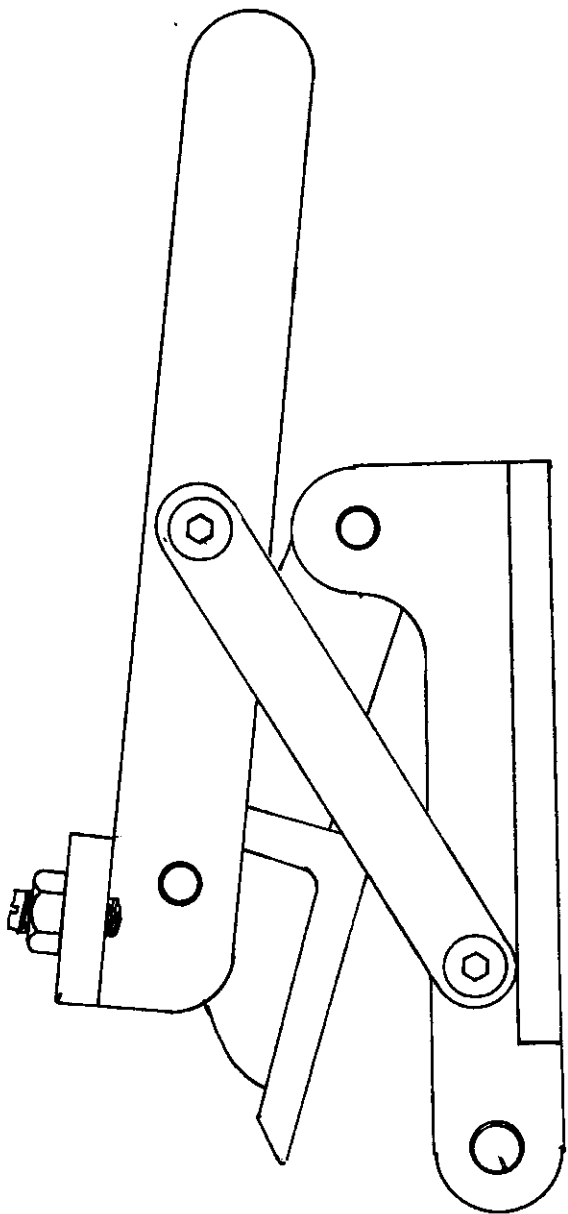

VIEW OF RIGHT END WITH CLAMP OPEN

ADJUSTING THE CLAMP

When you reassemble the parts after drilling and tapping the upper link pivot holes, it is likely that the lever will travel too far forward after passing over the center point. The adjustment screws will serve to limit the travel.

They are 1/4"-20 screws with a jamb nut to lock them when adjustment is satisfactory. You can use socket head set screws, or you can cut the heads from cap screws and provide a sawed slot for a screw driver.

When you move the lever to lock the clamp, you will feel the tension increase as you move towards the highest point. The ideal setting is when the lever moves just over the center into the locking position, and it takes a minimum of motion to release the clamp.

CORRECTING FOR ERRORS

It is most likely that everything will work well, but in case you have made minor errors, don't despair, they can be corrected.

If the clamp action is too tight, you can heat the clamp leaf pivot arms to a red heat as you tighten the clamp, and the tension will be relieved.

If the clamp action is too loose, you can put a spacer under the rear edge of the clamp leaf, and force the front edge down as you heat the pivot arms to a red heat.

Any corrections that were needed in any of the other pivot points should have been made before the clamp leaf was installed, so at this point, you should have a smooth working brake, all ready to clean up and paint.

FINISHING UP

The best appearance will be had if you disassemble the brake and paint the parts separately.

If any of the metal is rusty, you can use metal conditioner to etch the rust for good bond. It is sold by auto supply stores that handle material for auto body repair.

Otherwise, just clean up the rough areas, wash with a solvent, and spray on a coat of primer. Finish with two coats of enamel.

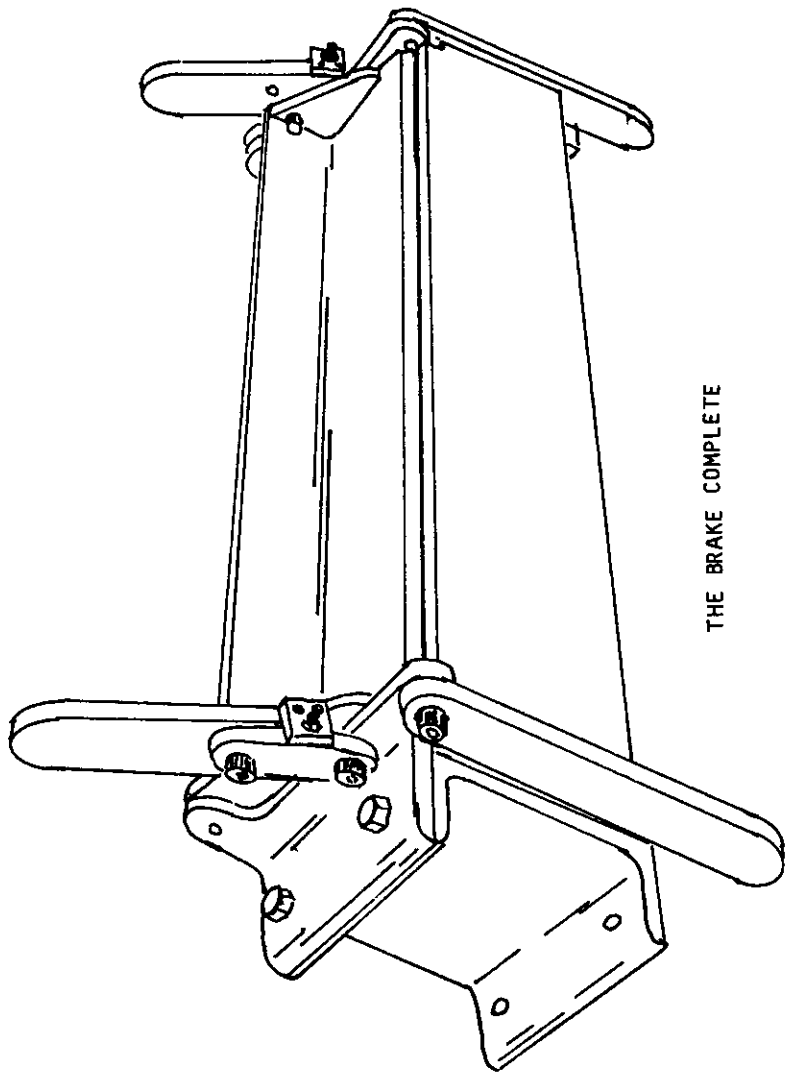

THE BRAKE COMPLETE

CHAPTER VII

HOW TO GET THE MOST OUT OF YOUR BRAKE

It is likely that you already know how to use a brake or you would not have wanted to build one. The intent here is to point out some useful kinks that will make you independent of the shop and the rest of the heavy equipment

Of course it is great to have all of the latest type of gear to do a job; but there are those of us who don't have it, and even if you do, there are times when it is too far away to do us any good. These methods may be of some value from time to time.

THE PITTSBURG SEAM

When you begin to install a duct system with limited equipment, the first item you will miss is the "Lockformer". This is the roll forming machine that makes the pittsburg seam to join a length of duct at its corner.

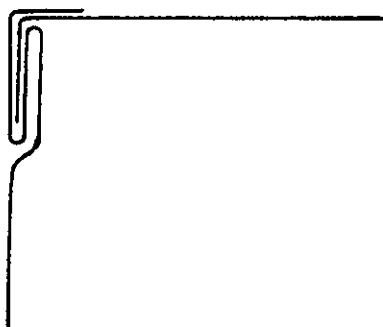

In usual trade practice, it is a simple matter to feed the edge of the blank into the lockformer, and just like magic, it comes out with a pittsburg seam. The truth is, the lockformer was invented to do a job that was once done by the leaf brake. You can do it on your portable

brake, or on any other leaf brake if you care to take the time and trouble. It's a little bit tedious, but there are times when only a pittsburg seam will do the job. It's worth knowing how to do.

The usual trade practice uses a 1-1/4" take up for the seam. That is, 1" is added to the lay-out for the pocket, and 1/4" is added for the tab.

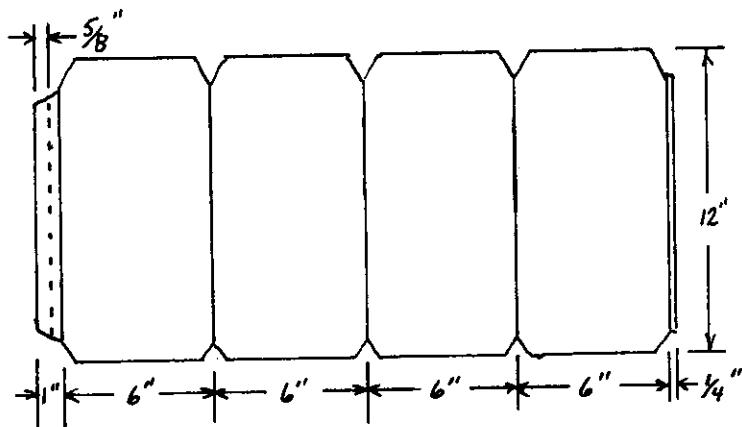

The sketch is a lay-out for a 12" length of 6" X 6" duct. In this case, all four sides of the duct will be equal. The pocket for the pittsburg seam will normally be formed on the smaller dimension. That is; if it were a piece of 14" X 8" duct, the pocket would be formed on the 8" side, and the 1/4" tab would be on the 14" side. This is the same lay-out that would be used if you were going to use the lockformer. You need just one additional mark at 5/8" from the pocket edge.

Slip the entire blank into the brake and clamp it on the 5/8" mark. Raise the bending leaf to make a 90 degree bend on the protruding 5/8".



Remove the blank, turn it over, and slip it back into the brake. Clamp it at the 1" mark, and bend it up to the full swing of the brake.



Drop the bending leaf, and with a scrap of sheet metal held in the angle, knock the 5/8" flange down with a mallet to form the pocket.

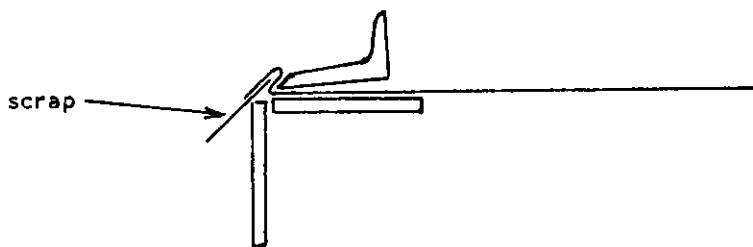

Leave the scrap in the pocket for now and squeeze the pocket down with the clamp leaf. You can help it by rapping on the clamp leaf with the mallet as you squeeze with the clamp lever. Don't use a hammer, You'll damage the leaf.

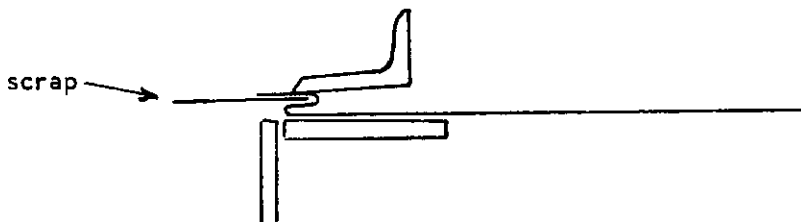

Now, remove the blank from the brake, turn it over again, slip it back in the brake, and clamp it about 1/8" behind the pocket.

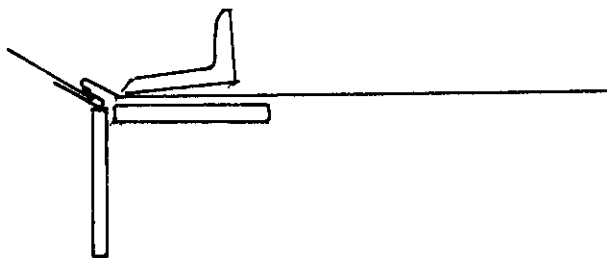

With the mallet, knock down the pocket so that the seam is horizontal, and you've got it. Remove the piece of scrap and you are ready to finish forming up your work.

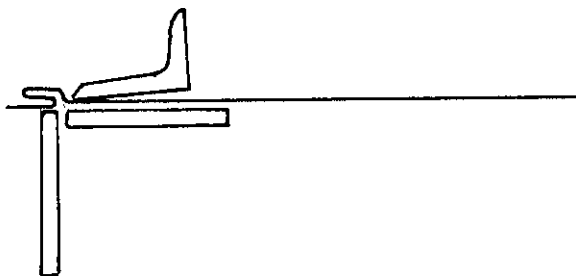

Remove the blank from the brake, turn it end for end, but don't turn it over; clamp it on the 1/4" mark, and bend the tab up 90 degrees. Un-clamp, move to the next mark, and bend up again. Bend the remaining two corners in the same manner, remove the work from the brake, slip the tab into the pocket, and close the seam with a hammer.



THE DOUBLE LAP CORNER SEAM

Although it makes a pretty piece of work, the pittsburg seam is tedious to do on the brake. There are some time and energy saving alternates.

If you try to join a piece of duct at the corner with a single lap and some screws or pop rivets, the inside will move away from the drill as you try to make the holes and, even if you succeed, it will be a sloppy joint. The secret is to use a double lap seam.

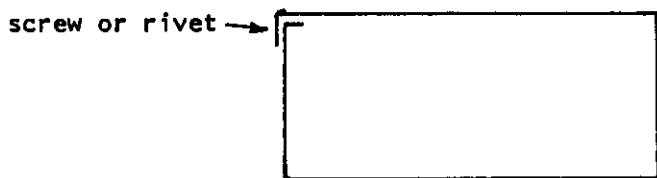

Simply add $5/8$ " to each end of the blank. The angle on the inside will stiffen the joint and align it while you drill for screws or rivets. It makes a strong and neat looking joint. It's simple, fast, and effective.

THE " S " SLIP

Usually, the lengths of duct will be joined together with an "S" slip on the horizontal joint. The common size is 11", and they are made both flat and standing.

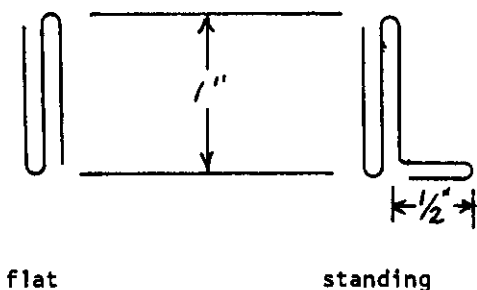

They make a fast substitute for the pittsburg seam. You can make them on the brake, but they are cheap, and if you need a lot of them, it might be better to buy them and save your time and energy for better things.

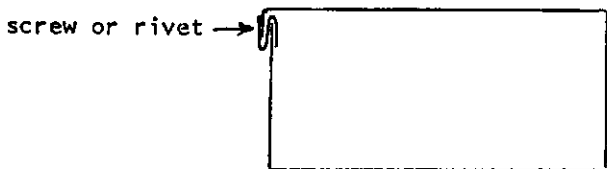

The "S" slip is equally as effective as a pocket seam for the plenum cap and front cover.

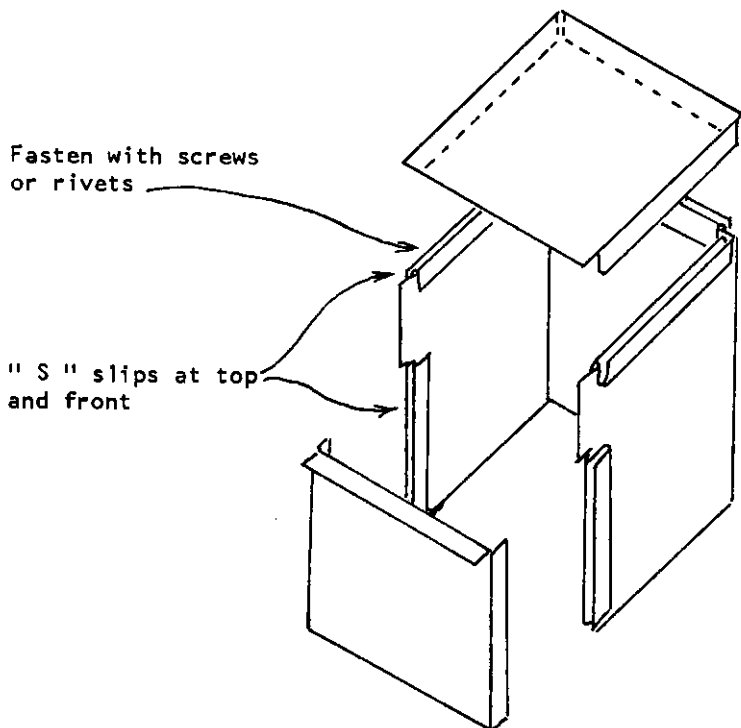

The standing "S" is normally used for wider spans of duct where the metal would sag if it didn't have extra support. While the angle is intended to stiffen the joint, it can also be useful as a flange to which you can screw an access panel, so that you can get to a filter or an air conditioning coil for installation and service.

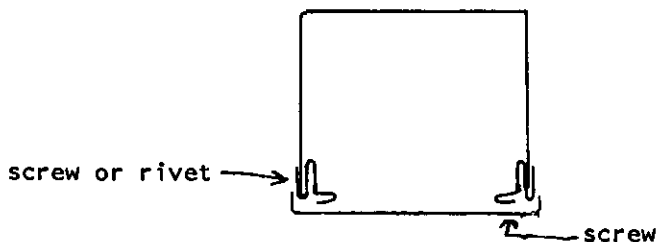

This kink is especially useful in a case where you are adding air conditioning to an existing forced air system. With the standing "S" slip, you can convert the existing plenum to a coil cabinet and save a lot of labor and material.

THE DRIVE SEAM

You can install an entire duct system using "S" slips with sheet metal screws to join each length of duct to the last, but it is faster and easier to use the "S" slips on the wide dimension, which is usually the bottom and top, and use drive cleats on the sides, or the narrow dimension.

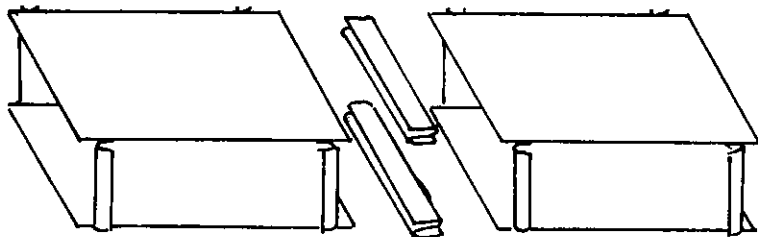

The "S" slips are put on the end of each length of duct, and they form a pocket for the next length. The drive cleats are formed on each side, and when the drive slip is driven onto the drive cleats, with a half inch or so protruding on each end to bend over, you have a strong and neat joint.

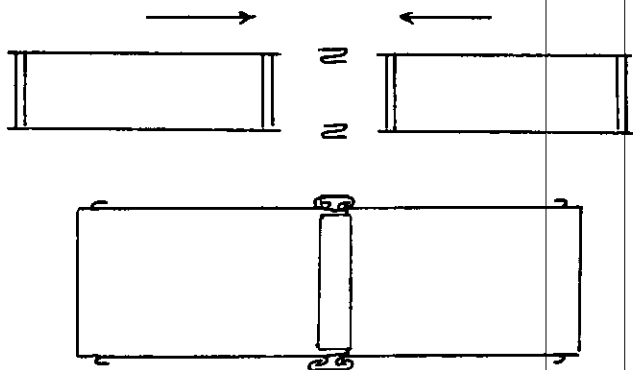

Of course, duct elbows, reducers, transitions, or any rectangular shape, can be made up on the spot, using the double lap corner joint or the "S" slips as a substitute for the pittsburg seam. When you take advantage of the wide array of standard round pipe fittings that are available for installing forced air systems, you need nothing more than a means to make up your plenums and rectangular duct and fittings, and you can do the job. The portable brake will fill your need.

You can also make a piece of round pipe in any size you need.

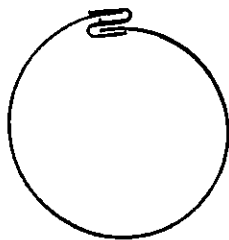

AN ENDLESS RANGE OF POSSIBILITY

While it is small and light weight, the portable brake is more than a toy; it can be a real work horse, and if you apply a little study to method, there is hardly a job you can't do with it.

In the home shop, you can make a belt guard, a chip pan for your lathe, a sawdust chute for your power saw, a special sized metal box or drawer; any number of useful items that would cost plenty if you could buy them.

By removing the lower link pivot pins, you can then swing the clamp leaf back out of the way. You can then clamp the metal with a block of wood and a "C" clamp so that you can make a small box or pan. Or, you can make an extra clamp leaf with slots cut with a hacksaw to use for making small boxes or metal drawers for your small parts and hardware.

I'm certain that you will find it a real pleasure to build and to use. It's an item that I almost left out of the "**METAL SHOP FROM SCRAP**" series, and I would have if it had not been for my metal shop friends who say, "I'm always wanting to bend a piece of sheet metal for something."

THE END

INDEX

- Adjustment, clamp 39
Angle brace 22
Assemble the parts 28
Bed leaf 19, 21
Bed leaf brace 20, 21
Bed parts 15
Bending leaf . . . 24, 25, 26, 27
Bending leaf brace 25
Bending leaf handles . . . 24, 26
Bending leaf pivot6, 8, 25
Bolt, shoulder 11
Brace, angle 22
Brace, bed leaf 20, 21
Brace, bending leaf 25
Bracket, pivot & clamp 13, 15, 17
Brake, leaf-defined 6
Check your work 24
Clamp, adjustment of 39
Clamp, eccentric 13
Clamp leaf, assemble . . 28, 29
Clamp leaf gussets28, 29
Clamp leaf pivot6, 9
Clamp leaf pivot arms . .28, 29
Clamp leaf, shaping the . . . 28
Clamp levers . . 33, 34, 37, 38
Clamp lever lug . . 33, 34, 35
Clamp lever pivot . . 9, 10, 33
Clamp links . . . 33, 35, 37, 38
Clamp, over center 9, 36
Clamp, toggle 9, 36
Complete the bed 21
Corner seam, double lap . . 45
Correcting pivot point . . 25, 39
Double lap corner seam . . . 45
Drill, tap size 14
Drilling, step 15
Drive seam 47, 48
Duct lay-out 42
Dye, tool makers 15
Eccentric clamp 13
Finishing 39
Gussets, clamp leaf . . 28, 29
Handle, bending leaf . . 24, 26
Lap, double corner seam . . 45
Lay-out, duct 42
Leaf, bending 24, 26, 27
Leaf brake defined 6
Leg, mounting 18
Lever, clamp . . 33, 34, 37, 38
Link, clamp . . . 33, 35, 37, 38
Link pivot 10, 36
List, material 12
Lock-former 41
Lug, clamp lever stop . . . 33, 34, 35
Main bed parts 15
Material list 12
Material, selecting 11
Mounting leg 18
Over center clamp 9, 36
Pittsburg seam 41, 42
Pivot arms, clamp leaf . 28, 29
Pivot, bending leaf . . 6, 8, 25
Pivot & clamp bracket-13, 15, 17
Pivot, clamp leaf 6, 9
Pivot, clamp lever . . 9, 10, 33

INDEX

Pivot, link	10, 36	Step drilling	15
Pivot point, correcting -	25, 39	Stop lug	33
Plenum	45	Tap size, drill	14
Round pipe	48	Tapping threads	14, 15, 16
"S" slip	45	Toggle clamp	9, 36
Seam, double lap corner . .	45	Tool makers dye	15
Seam, drive	47, 48	Tools required	14
Set up to build	16	Upper link pivot hole	36
Shaping, clamp leaf	29	Welding	14
Seam, pittsburg	41, 42	Welding, bed leaf	21
Selecting material	11	Welding, bed leaf brace	21
Shoulder bolt	11	Welding bending leaf	25
Size to build	13	Welding, bending leaf brace-	25
Skip welding	14		

Index to illustrations on page 4

The main purpose for publishing the "Metal Shop From Scrap" series was to present methods for building such equipment as is normally found in a machine shop. Lathes, shapers, milling machines and their accessories fall into that category easily. A bending brake can certainly find plenty of use in any shop, and many metal working projects can be greatly simplified by the use of sheet metal rather than castings, forgings or other structural forms. It is well that we included it in the series for it has proven to be one of the more popular titles.

This is a welding project rather than a casting and machining project, though obviously some of the members of the brake could be redesigned as castings. You can find much or all of what you need to build the brake at the local salvage yard. This is a light duty portable leaf brake. Of course heavy work will require a larger, heavier piece of equipment, but you will find the basic principles here.

Simple operations such as cutting squarely to a line with a hacksaw or drilling a hole precisely on location require a measure of skill. The ability is gained through understanding basic principles and by practice. "Learn to do it right and apply what you know!" You'll find a worthwhile series of productive exercises in this project, and the result will be a compact sheet metal brake that will greatly expand your shop capability.

The "Build Your Own Metal Working Shop From Scrap" Series:

- | | |
|--------|--|
| Book 1 | The Charcoal Foundry |
| Book 2 | The Metal Lathe |
| Book 3 | The Metal Shaper |
| Book 4 | The Milling Machine |
| Book 5 | The Drill Press |
| Book 6 | The Dividing Head & Deluxe Accessories |
| Book 7 | Designing & Building The Sheet Metal Brake |

ISBN 1-878087-06-1

